

ARMY TM 9-2355-106-23-5
AIR FORCE TO 36A12-1C-2400-2-5

TECHNICAL MANUAL
FIELD MAINTENANCE MANUAL
FOR
MINE RESISTANT AMBUSH PROTECTED (MRAP)
M1224
(NSN 2355-01-553-4634) (EIC 1XF)
M1224A1
(NSN 2355-01-561-0281) (EIC 1XM)

DISCLOSURE NOTICE – This information is furnished upon the condition that it will not be released to another nation without the specific authority of the Department of the Army of the United States, that it will be used for military purposes only, that individual or corporate rights originating in the information, whether patented or not, will be respected, that the recipient will report promptly to the United States, any known or suspected compromise, and that the information will be provided substantially the same degree of security afforded it by the Department of Defense of the United States. Also, regardless of any other markings on the document, it will not be downgraded or declassified without written approval of the originating United States agency.

DISTRIBUTION STATEMENT C – Distribution authorized to U.S. Government Agencies and their contractors only for Specific Authority as determined on 01 August 2012. Other requests for this document shall be referred to TACOM Life Cycle Management Command, ATTN: AMSTA-LCC-MMK, Warren, MI 48397-5000.

WARNING – This document contains technical data whose export is restricted by the Arms Export Control Act (Title 22, U.S.C., Sec 2751, et seq) or the Export Administration Act of 1979, as amended, Title 50, U.S.C., App. 2401 et seq. Violations of these export laws are subject to severe criminal penalties. Disseminate in accordance with provisions of DoD Directive 5230.25.

DESTRUCTION NOTICE – Destroy by any method that will prevent disclosure of contents or reconstruction of contents.

HEADQUARTERS, DEPARTMENTS OF THE ARMY AND AIR FORCE
19 NOVEMBER 2012

WARNING SUMMARY

EXPLANATION OF WARNING ICONS

This warning summary contains general safety warnings and hazardous materials warnings that must be understood and applied during operation and maintenance of this equipment. Failure to observe these precautions could result in serious injury or death to personnel. Also included are explanations of safety and hazardous materials icons used within the technical manual.

FIRST AID

First aid is the emergency care given to the sick, injured, or wounded before being treated by medical personnel. First aid data can be found in FM 4-25.11. This manual contains procedures for all types of casualties and the measures described are for use by all service members. Service members may be able to save a life, prevent permanent disability, or reduce long periods of hospitalization by knowing WHAT to do, WHAT NOT to do, and WHEN to seek medical assistance.

WARNING SUMMARY – (Continued)

EXPLANATION OF GENERAL SAFETY ICONS



EAR PROTECTION – headphones over ears shows that noise level will harm ears.



ELECTRICAL – electrical wire to arm with electricity symbol running through body shows that shock hazard is present.



ELECTRICAL – electrical wire to hand with electricity symbol running through body shows that shock hazard is present.



FALLING PARTS – arrow bouncing off human shoulder and head shows that falling parts present a danger to life or limb.



FLYING PARTICLES – arrows bouncing off face shows that particles flying through air will harm face.



FLYING PARTICLES – arrows bouncing off face with face shield shows that particles flying through the air will harm face.



HEAVY OBJECT – human figure stooping over heavy object shows physical injury potential from improper lifting technique.



HEAVY PARTS – foot with heavy object on top shows that heavy parts can crush and harm.



HEAVY PARTS – heavy object on human figure shows that heavy parts present a danger to life or limb.

WARNING SUMMARY – (Continued)



HEAVY PARTS – heavy object pinning human figure against wall shows that heavy, moving parts present a danger to life or limb.



HELMET PROTECTION – arrow bouncing of head with helmet shows that falling parts present a danger.



HOT AREA – hand over object radiating heat shows that part is hot and can burn.

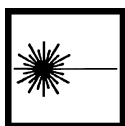

LASER LIGHT – laser light hazard symbol indicates extreme danger for eyes from laser beams and reflections.



MOVING PARTS – human figure with an arm caught between gears shows that the moving parts of the equipment present a danger to life or limb.



MOVING PARTS – hand with fingers caught between gears shows that the moving parts of the equipment present a danger to life or limb.



MOVING PARTS – hand with fingers caught between rollers shows that the moving parts of the equipment present a danger to life or limb.



SHARP OBJECT – pointed object in hand shows that a sharp object presents a danger to life or limb.



SHARP OBJECT – pointed object in hand shows that a sharp object presents a danger to life or limb.

WARNING SUMMARY – (Continued)



SHARP OBJECT – pointed object in foot shows that a sharp object presents a danger to life or limb.



SLICK FLOOR – wavy line on floor with legs prone shows that slick floor presents a danger for falling.



EYE PROTECTION – person with goggles shows that the material will injure the eyes.

GENERAL WARNINGS

WARNING



Before performing any maintenance procedure, ensure vehicle is parked on level surface, engine is off, parking brake is applied, transmission is in NEUTRAL (N), and wheels are chocked. Wear eye protection and stay clear of rotating parts and hot surfaces. Make sure all electrical tools are grounded. Use extreme caution when working under vehicle. Use hydraulic jack to raise vehicle, and place jackstands under frame rails to support axle. Keep first-aid and fire-control equipment available during all operation and maintenance procedures. Failure to comply may result in damage to equipment and serious injury or death to personnel.

WARNING

A/C



Do not install or remove air-conditioning testing or charging equipment while engine is running. Failure to comply may result in serious injury or death to personnel.

WARNING

AIR DRAIN VALVES

WARNING SUMMARY – (Continued)



Air drain valves are under pressure. Wear protective goggles and do not place face in front of air drain valves while draining air reservoirs. Open air drain valves slowly to release air pressure gradually. Failure to comply may result in serious injury or death to personnel.

WARNING

AIR LINES

Do not disconnect any air line or fitting until system pressure has been relieved. Hoses may whip and injure personnel, and air under pressure can penetrate skin. Failure to comply may result in serious injury or death to personnel.

Do not operate vehicle with air pressure system loss. Vehicle has reduced or no braking capability and may not stop. Failure to comply may result in damage to equipment and serious injury or death to personnel.

WARNING

BATTERIES



Wear protective eye goggles, face shield, and long sleeves when working on or near batteries. Batteries contain corrosive acid and can produce explosive gases. Batteries supply electrical current that can cause burns and electrical shock. Always check electrolyte level with engine off. Avoid leaning over or onto battery. Do not wear jewelry and do not smoke or have open flame or spark near battery. Do not allow tools to contact battery box or battery terminals. Failure to comply may result in damage to equipment and serious injury or death to personnel.

Battery acid must not contact eyes, skin, or clothing. If battery acid contacts eyes or skin, flush area with large amounts of water for 15 minutes and seek immediate medical care. If swallowed, do not induce vomiting. Drink large amounts of water or milk. Follow with milk of magnesia, beaten egg, or vegetable oil. Seek immediate medical attention. Failure to comply may result in serious injury or death to personnel.

Disconnect battery ground cable or power source prior to working on electrical components. If electrical shock occurs, administer first aid and seek medical assistance immediately. Failure to comply may result in serious injury or death to personnel.

Ensure batteries are disconnected before removing ESC. Failure to comply may result in serious injury or death to personnel.

WARNING SUMMARY – (Continued)

WARNING

BRAKES (ALSO SEE HAZARDOUS MATERIALS WARNINGS)

Before working on air brake system or any auxiliary pressurized system, make sure air pressure has been drained from all reservoirs. Failure to comply may result in serious injury or death to personnel.

If springs are missing or damaged, replace with new spring hardware kit before installing new brake shoes. Replace brake shoes if there are any signs of overheating, if step on center wear tab of brake shoe lining is not visible, or if thickness on any part of brake shoe is ¼ in. (6 mm) or less. Drums must be turned or replaced if there were any signs of overheating on old brake shoes. Failure to comply may result in damage to equipment and serious injury or death to personnel.

Do not allow grease or oil to contact brake linings. Linings can absorb grease and oil, causing early glazing and reduced braking action. Failure to comply may result in serious injury or death to personnel.

Before removing ABS Control Module, disconnect battery disconnect switch and disconnect batteries. Failure to comply may result in damage to equipment and serious injury or death to personnel.

WARNING

CAB DOOR WINCH STRAPS



Cab doors must be secured in the open position by using heavy duty winch straps to prevent accidental closure during vehicle maintenance. Failure to comply may result in serious injury or death to personnel.

WARNING

COMPRESSED AIR

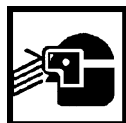

Do not use compressed air exceeding 30 psi (207 kPa) for cleaning purposes. Use only with effective chip-guarding and personal protective equipment, including goggles or face shield and gloves. Failure to comply could result in serious injury or death to personnel.

WARNING

COOLING SYSTEM/RADIATOR

WARNING SUMMARY – (Continued)

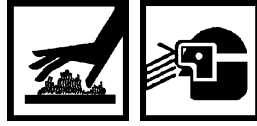

Cooling system components become pressurized and extremely hot during normal operation. To prevent serious injury from hot coolant or scalding steam, use the following safety procedure when removing radiator cap, surge tank cap, or deaeration cap:

- Allow engine to cool for 15 minutes.
- Wrap a thick cloth around cap to be removed.
- Loosen cap slowly one-quarter to one-half turn counterclockwise, and pause to allow pressure to release.
- Continue to turn cap counterclockwise to remove.

Ensure all personnel stay clear of radiator while engine is running. Air in radiator will be released, which may cause hot coolant to spray out. Failure to comply may result in serious injury to personnel.

WARNING

DMM (DIGITAL MULTIMETER)



Ensure power is off before cutting, soldering, or removing a circuit component to insert the Digital Multi-meter (DMM) for current measurements. Even small amounts of current can be dangerous. Failure to comply may result in serious injury to personnel.

When routing DMM leads, do not crimp leads, run leads too close to moving parts, or let leads touch hot engine surfaces. Failure to comply may result in serious injury to personnel.

WARNING

ELECTRICAL



Turn off ignition switch and main power switch before performing electrical system maintenance. Failure to comply may result in serious injury or death to personnel.

Disconnect negative ground cable from batteries before removing any electrical component. Failure to comply may result in serious injury or death to personnel.

Never attempt a voltage measurement with test probe lead in current jack (10A or 300mA). Failure to comply may result in serious injury to personnel.

Shut engine down before performing voltage checks for injector solenoids. When engine is running, injector circuits have high voltage and amperage. Failure to comply may result in serious injury to personnel.

WARNING SUMMARY – (Continued)

Do not use a circuit breaker, fuse, or relay with higher amperage rating than listed for a particular application. Using higher amperage will overheat the electrical circuit, causing melted components and possible fire. Failure to comply may result in damage to equipment and serious injury or death to personnel.

WARNING

ENGINE (ALSO SEE HAZARDOUS MATERIALS WARNINGS.)

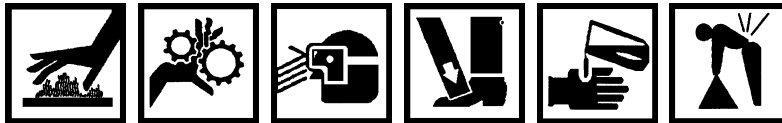

Engine components become extremely hot during normal operation. Allow engine to cool completely prior to performing maintenance. Use extreme care when working in close quarters in engine compartment. Stay clear of rotating parts. Wear safety goggles, work gloves, and long sleeves or shop coat. Failure to comply may result in serious injury or death to personnel.

Some engine components are heavy and bulky and require assistance for lifting. Use assistance of crewmember or lifting device as required. Failure to comply may result in damage to equipment and serious injury to personnel.

Do not rotate diesel engine when priming with oil. This may cause engine to accidentally start. Failure to comply may result in serious injury or death to personnel.

Prior to performing work on crossmember, place wooden block between crossmember and front engine mount. Failure to comply may result in damage to equipment and serious injury to personnel.

WARNING

EMERGENCY HATCH



Emergency hatch door is extremely heavy. Use caution and keep arms, hands, and head clear of hatch when opening or closing. Ensure hatch door is properly secured in both the open or closed position. Do not operate vehicle with emergency roof hatch open. Failure to comply may result in serious injury or death to personnel.

Use lifting device capable of lifting 1000 lbs to lift emergency hatch from vehicle. Clear all nonessential personnel from area when lifting hatch from vehicle. Do not stand directly under hatch door while lowering to floor. Failure to comply may result in damage to equipment and serious injury or death to personnel.

WARNING

EXHAUST

WARNING SUMMARY – (Continued)

Exhaust system components can be hot. Do not touch with bare hands or allow contact with other skin surface. Wear protective work gloves and long sleeves. Do not use exhaust tailpipe as a step. Failure to comply may result in damage to equipment and serious injury or death to personnel.

WARNING**FAN BLADE**

Do not attempt to restrict fan blade rotation during engine operation. Improper use of application or modification of fan drive or fan can damage fan drive. Do not operate vehicle with malfunctioning or damaged fan drive or fan blades. Failure to comply may result in damage to equipment and serious injury to personnel.

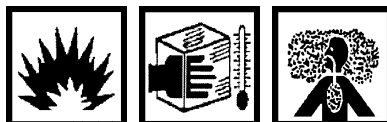
WARNING**FSS (FIRE SUPPRESSION SYSTEM)**

Before installing FSS extinguisher, verify correct part number is being installed. Check for visible damage to the canister, such as dents, cracked plastic, chips, or scratches where hoses connect. If damage is visible anywhere, do not use; contact your supervisor. Failure to comply may result in damage to equipment and serious injury or death to personnel.

Prior to servicing FSS, make sure FSS power is off, main power switch is off, unless otherwise instructed. If damage is visible, anywhere, do not use. Contact your supervisor. Failure to comply may result in discharging of system and serious injury or death to personnel.

Before handling extinguisher, make sure anti-recoil plug is installed in valve outlet port and mechanical lever lockpin is installed in lever lock holes. Failure to comply may result in damage to equipment and serious injury or death to personnel.

Some fire suppression systems have a safety pin to install before disconnecting lines. Check to see if system uses a safety pin and install it before disconnecting lines. When disconnecting the extinguisher lines, use extreme caution. Do not disturb the pyrotechnic actuator and pressure switch; this will cause the extinguisher to discharge automatically. Failure to comply may result in damage to equipment and serious injury or death to personnel.

WARNING SUMMARY – (Continued)

Do not drop or strike FSS extinguisher. Extinguisher can discharge accidentally and chemical agent can escape through holes in side of ant-recoil plug. Failure to comply may result in damage to equipment and serious injury or death to personnel.

Do not release extinguisher bottle band clamps unless anti-recoil plug is installed in valve outlet port and mechanical lever lockpin is installed in lever lock holes. Failure to comply may result in personal injury or death, or damage to equipment.

FSS extinguisher can move violently when discharging. Ensure extinguisher is properly secured during use. Failure to comply may result in damage to equipment and serious injury or death to personnel.

Replace fire extinguisher immediately after use, even if only partly used. Failure to comply may result in serious injury or death to personnel.

Exposure to large quantities of dry chemical fire extinguisher in cab may result in temporary breathing difficulty during and immediately after discharge. If possible, discharge fire extinguisher from outside cab. Ventilate and wash cab thoroughly prior to reentry. If respiratory irritation or distress occurs, move victim to fresh air. Seek medical attention if irritation persists.

Chemical fire suppression agents are refrigerants and can freeze skin. Extinguisher will be extremely cold after discharging. Avoid contact with chemical agent and do not touch extinguisher after use. Failure to comply may result in serious personal injury.

WARNING

FUEL LINES/PUMP



Do not loosen fuel lines at filter housing to bleed fuel system. Periodic loosening of fittings will result in increased thread wear. Failure to comply may result in damage to equipment and serious injury or death to personnel.

Do not overtighten bolts for fuel pump or cross-thread connections on fuel lines. This will interfere with sealing and operation of fuel pump. If seal is not complete or lines leak due to cross-threads, fuel pump will not operate properly and vehicle may not run. Starting vehicle without fuel pressure in lines or pump may result in damage to equipment and serious injury or death to personnel.

WARNING

GUNNER HATCH



WARNING SUMMARY – (Continued)

Gunner hatch is extremely heavy. Use caution when opening and closing. Wear safety goggles when removing, installing, or working on interior of gunner hatch. Keep arms and hands clear of gunner hatch when closing. Failure to comply may result in damage to equipment and serious injury or death to personnel.

Gunner sliding hatch can only be opened or closed when vehicle is stationary and on level surface. Do not attempt to open or close the hatch when vehicle is in motion. Make sure latch locks are secured into place in the open or closed positions before vehicle starts moving. Failure to comply may result in damage to equipment and serious injury or death to personnel.

Ensure gunner hatch is completely locked in open position before moving vehicle with gunner in position. Use extreme caution when standing in gunner hatch while vehicle is in motion. Gunner should be holding onto weapon or other support to maintain stability at all times. Failure to comply may result in serious injury or death to personnel.

WARNING HEATSHRINK TUBING



Never use open flame to apply heat to heatshrink tubing. Allow heatshrink tubing to cool before handling. Failure to comply may result in serious injury to personnel.

WARNING HEAVY LIFTING



Prior to moving heavy components with lifting device, clear path of travel and clear personnel from area. Use extreme caution if lifting objects overhead or backing up. Stop and lower load as soon as possible. Failure to comply may result in damage to equipment and serious injury or death to personnel.

WARNING HOOD

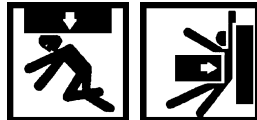

Hood is extremely heavy. Ensure there is adequate space to open hood completely without pinning personnel between hood and another structure. Use extreme care when working under hood and make sure it is properly supported. Failure to comply may result in serious injury or death to personnel.

WARNING SUMMARY – (Continued)

WARNING

INSTRUMENT PANEL



The instrument panel is bulky and heavy and cannot be removed by one person. Before removing the side A-pillar mounting bolts, obtain assistance for remainder of removal. Failure to comply may result in damage to equipment and serious injury or death to personnel.

WARNING

JACKS



Before lifting vehicle off ground, make sure it is parked on level surface. Set parking brake and chock wheels. Use hydraulic jack to lift vehicle. Do not use jack alone to support vehicle. Never work under or near a vehicle supported only by jack or lifting device. Use rated jackstands under frame rails to properly support vehicle. Do not support vehicle under front and rear axles. Use additional jackstands as necessary to support vehicle components during removal and installation procedures. Failure to comply may result in damage to equipment and serious injury or death to personnel.

WARNING

LITTER



Keep personnel clear of litter-lift moving parts. Ensure litters and patients are properly secured and clear of rear door/ramp and all other obstacles during litter-lift movement. Failure to comply may result in serious injury or death to personnel.

Hold litter stub and connector plate up while removing or installing hex-head screws from bracket. If connector plate and stub fall and slide down stainless sliding rail, serious damage to parts may occur. Failure to comply may result in serious injury or death to personnel.

WARNING

PITMAN ARM

Pitman arm will be extremely tight. Do not pound on pitman arm or apply heat to pitman arm or sector shaft. Never weld pitman arm or sector shaft. Failure to comply may result in damage to equipment and serious injury or death to personnel.

WARNING SUMMARY – (Continued)

Proper installation of pitman is critical to vehicle safety. Install pitman arm after steering gear is mounted on vehicle so proper torque can be applied to pitman arm. Otherwise, pitman arm could loosen and cause an accident. If pitman arm is loose, replace pitman arm and sector shaft. Always use a new tab lock retainer. If tabs and notches do not line up, tighten beyond specified torque value until two tabs align. Never back off retainer to align retaining tabs. Failure to comply may result in damage to equipment and serious injury or death to personnel.

When installing new cotter pin, tighten nut until slot appears and insert cotter pin. Never back off nut to install cotter pin. Failure to comply may result in damage to equipment and serious injury or death to personnel.

WARNING

REAR CABIN DOOR/RAMP



Rear cabin door/ramp is heavy. Make sure door/ramp is secured so it will not move. Failure to comply may result in serious personal injury or death to personnel.

Ensure no one is behind vehicle when lowering rear door/ramp. Use extreme caution when using emergency rear door/ramp release, to ensure no one is struck by door as it falls open. Keep arms and legs clear of rear door/ramp when closing. Do not operate rear door/ramp when vehicle is in motion. Failure to comply may result in serious injury or death to personnel.

Attach a lifting device and sling to rear door/ramp prior to removing mounting bolts. Failure to comply may result in damage to equipment and serious injury or death to personnel.

Rear door/ramp is heavy. Ensure lifting device and sling are in place prior to removing rear door/ramp mounting bolts. Failure to comply may result in serious injury or death to personnel.

WARNING

RIFLES

Remove rifles from rifle racks being worked on. Ensure rifles are not loaded and store in safe manner. Failure to comply may result in serious injury or death to personnel.

WARNING

TOWING EYES

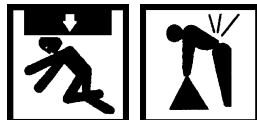

Do not remove both rear towing eyes at the same time, Entire rear frame crossmember assembly will fall. Replace one towing eye at a time. Failure to comply may result in damage to equipment and serious injury or death to personnel.

WARNING SUMMARY – (Continued)

WARNING

TRANSFER CASE

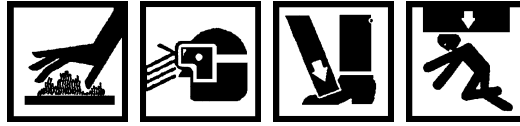

During normal vehicle operation, transfer case and oil cooler can become very hot. Allow transfer case and oil cooler to cool prior to servicing oil cooler. Wear safety goggles, work gloves, and protective clothing. Use extreme caution when opening drain valves and removing bolts. Failure to comply may result in serious injury to personnel.

WARNING

TRANSMISSION



Use care when working with hot transmission and fluid during maintenance procedures. Wear protective goggles, work gloves, and long sleeves to avoid injury. Avoid contact with hot transmission oil or sump when draining transmission oil. If transmission oil temperature is above 220°F (104°C), allow transmission oil to cool before removing dipstick. Failure to comply may result in serious injury or death to personnel.

WARNING

WHEELS/TIRES



Wheel and tire assemblies are heavy. Do not attempt to lift wheel and tire assemblies without assistance from crewmember. Wear safety goggles and work gloves. Failure to comply may result in damage to equipment and serious injury or death to personnel.

Ensure vehicle is parked on hard, level surface before changing wheel and tire assembly. Soft or uneven ground may cause jack or jackstand to slip, resulting in damage to equipment and serious injury or death to personnel.

EXPLANATION OF HAZARDOUS MATERIALS ICONS

WARNING SUMMARY – (Continued)



BIOLOGICAL – abstract symbol bug shows that a material may contain bacteria or viruses that present a danger to life or health.



CHEMICAL – drops of liquid on hand shows that the material will cause burns or irritation to human skin or tissue.



CRYOGENIC – hand in block of ice shows that the material is extremely cold and can injure human skin or tissue.



EXPLOSION – rapidly expanding symbol shows that the material may explode if subjected to high temperatures, sources of ignition or high pressure.



FIRE – flame shows that a material may ignite and cause burns.



POISON – skull and crossbones shows that a material is poisonous or is a danger to life.



RADIATION – three circular wedges shows that the material emits radioactive energy and can injure human tissue.



VAPOR – human figure in a cloud shows that material vapors present a danger to life or health.

WARNING



ANTI-SEIZE COMPOUND

WARNING SUMMARY – (Continued)

Anti-seize compound is flammable and toxic. Container may explode from excessive heat. Vapors can cause headache, dizziness, unconsciousness, corneal injury, and respiratory tract irritation. Use only in well-ventilated area. Use approved respirator with dual organic vapor/mist and particulate cartridge. Wear chemical safety goggles and full-face shield when using. Avoid contact with skin and wear rubber or plastic, solvent-resistant gloves. In case of contact, remove contaminated clothing and immediately wash area with soap and water. If compound contacts eyes, flush eyes with large amounts of water for at least 15 minutes and obtain immediate medical attention. If swallowed, do not induce vomiting; obtain immediate medical attention. Failure to comply may result in serious injury or death to personnel.

WARNING**ASBESTOS**

Brake dust contains asbestos, a known health hazard. Always wear safety goggles and an approved respirator during all brake service procedures. Wear respirator during removal of wheels through assembly. Handle all brake parts with care; brake dust covers all brake parts. Failure to comply may result in serious injury or death to personnel.

Never use compressed air or dry brushing to clean brake parts or assemblies. Use an industrial vacuum cleaner with a HEPA filter system to clean dust from brake drums, backing plates, and other brake parts. After vacuuming, remove any remaining dust with a rag soaked in water and wrung until nearly dry. Carefully clean parts in a well-ventilated or open-air area. During brake disassembly, carefully place all parts on the floor to avoid getting dust into the air. Do not use compressed air to clean clothing after working on brakes; use vacuum with HEPA filter system. Failure to comply may result in serious injury or death to personnel.

WARNING**CARBON MONOXIDE**

Carbon monoxide is a colorless, odorless, and dangerous gas that deprives the body of oxygen and causes suffocation. Use the following precautions to avoid carbon monoxide poisoning. Failure to comply may result in permanent brain damage or death to personnel.

- Do not idle engine for long periods of time.
- If necessary to run engine in confined area during vehicle service, use proper equipment to vent exhaust gasses outside work area.
- Do not operate personnel heater in enclosed area without adequate ventilation.
- Turn auxiliary diesel heater switch off before filling any fuel tank on vehicle.
- Do not sleep in vehicle with heater operating or engine idling.
- Notify Field Maintenance if exhaust fumes are detected in crew compartment while operating the vehicle.
- Be alert at all times for exhaust odors and symptoms of exposure to carbon monoxide, such as headaches, dizziness, loss of muscular control, apparent drowsiness, and coma. If symptoms are evident, move affected personnel to fresh air, keep them warm, do not permit physical exercise, administer artificial respiration (if necessary), and seek immediate medical attention.

WARNING

WARNING SUMMARY – (Continued)**CARC (CHEMICAL AGENT RESISTANT COATING)**

Vehicles are finished with a chemical agent resistant coating (CARC). CARC contains isocyanates, which are highly irritating to skin and respiratory system. Breathing CARC vapor or dried paint dust can cause coughing, shortness of breath, burning sensation in throat and nose, watering of eyes, pain during respiration, and chest tightness. Skin contact with particulates can cause itching or redness of skin. Sensitivity to isocyanates may increase from repeated exposure. Use the following precautions to prevent injury from exposure. Failure to comply may result in serious injury to personnel.

- Never weld or cut CARC coated surfaces. Grinding or sanding CARC coated surfaces will create harmful dust.
- Personnel who have lung or breathing problems or who have had a reaction to isocyanates must not be in any area where CARC painting operations are performed or CARC dust particles are present.
- CARC painting operations must be performed only by qualified painters wearing protective gear and respirators and working in fully equipped facilities. All personnel in the area must wear high-efficiency air purifying respirators, protective goggles, gloves, and other protective clothing. Thoroughly wash all clothing before reuse.

WARNING**CLEANING SOLVENTS**

Adhesives, solvents, and sealing compounds can burn easily, can give off harmful vapors, and are harmful to skin and clothing. Wear goggles and protective clothing. Keep away from open flame and use in well-ventilated area. If adhesive, solvent, or sealing compound get on skin or clothing, wash immediately with soap and water. Failure to comply may result in injury or death to personnel.

WARNING**CONNECTOR LUBRICANT**

Connector lubricant is harmful to skin and eyes. If lubricant contacts eyes, rinse thoroughly and contact physician if irritation persists. If skin is contacted, wash thoroughly with soap and water. Failure to comply may result in serious injury to personnel.

WARNING**CORROSION PREVENTIVE COMPOUND**

WARNING SUMMARY – (Continued)

Corrosion preventive compound is toxic. Use only in well-ventilated area. Use approved respirator with dual organic vapor/mist and particulate cartridge. Do not get in eyes; wear chemical safety goggles and full-face shield when using. Avoid contact with skin and wear rubber or plastic, solvent-resistant gloves. In case of contact, remove contaminated clothing and immediately wash area with soap and water. If compound contacts eyes, flush eyes with large amounts of water for at least 15 minutes and get immediate medical attention. If swallowed, do not induce vomiting; contact a physician immediately. Failure to comply may result in serious injury or death to personnel.

WARNING



DIELECTRIC GREASE

Dielectric grease is harmful to skin and eyes. If grease contacts eyes, rinse thoroughly and contact physician if irritation persists. If skin is contacted, wash thoroughly with soap and water. Failure to comply may result in serious injury to personnel.

WARNING



ETHER CANISTER

Ether canisters contain hazardous, combustible and flammable materials. Handle with care and dispose of in accordance with standard operating procedures. Use approved respirator with dual organic vapor/mist and particulate cartridge. Avoid contact with skin and eyes, and avoid breathing fumes. If swallowed, do not induce vomiting. Obtain immediate medical attention. Failure to comply may result in serious injury or death to personnel.

Ether canisters are pressurized, combustible and flammable. Keep away from flames and sparks. Do not incinerate or puncture canister. Do not expose to temperatures above 120°F (49°C). Do not store spare canister in vehicle cab. Failure to comply may result in serious injury or death to personnel.

WARNING



ENGINE FLUIDS

Engine fluids (oil, fuel, and coolant) may flammable and may be hazardous to human health and the environment. Handle all fluids and other contaminated materials (such as filters and rags) in accordance with standard operating procedures. Recycle or dispose of engine fluids, filters, and other contaminated materials in accordance with standard operating procedures. Failure to comply may result in environmental damage and injury to personnel.

WARNING

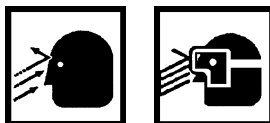

WARNING SUMMARY – (Continued)

FIBERGLASS

Direct contact with fiberglass materials or exposure to airborne fiberglass dust may irritate skin, eyes, nose, and throat. Minimize exposure to fiberglass particles by wearing long sleeves and long pants, work gloves, hat, and face shield or safety goggles with side shields. Personnel who experience irritation or have a known sensitivity should wear an approved particulate respirator. After working with fiberglass materials, wash skin with soap and running water and change clothing before touching eyes. Failure to comply may result in injury to personnel.

WARNING



FUEL

Fuel is flammable and can explode. Keep all open flames, flammable materials, ignition sources, and sparks away from diesel fuel and keep fire extinguisher nearby. Do not smoke when working with fuel. Do not work on fuel system when engine is hot. Fuel can be ignited by hot engine. Failure to comply may result in serious injury or death to personnel.

Be alert at all times for the smell of fuel. Hot engines and components can ignite fuel. If fuel smell is detected while operating vehicle, shut down vehicle immediately. Failure to comply may result in damage to equipment and serious injury or death to personnel.

Store diesel fuel in an approved container clearly marked DIESEL FUEL or JP-8, accordingly. Dispose of fuel in an approved container clearly marked DIESEL FUEL or JP-8, accordingly, in accordance with standard operating procedures.

Never use diesel fuel or JP-8 to clean parts. Fuel is highly flammable. Failure to comply may result in damage to equipment and serious injury or death to personnel.

WARNING



HYDRAULIC FLUID

Hydraulic fluid is flammable and harmful to skin and eyes. Wear work gloves and eye protection when handling fluids. Do not perform maintenance while smoking or near flame or sparks. If fluid contacts skin, wash affected area immediately. In case of eye contact, flush with water for 15 minutes and seek medical care immediately. Dispose of hydraulic fluid in accordance with standard operating procedures. Failure to comply may result in serious injury to personnel.

WARNING



NBC (NUCLEAR, BIOLOGICAL, and CHEMICAL) SYSTEM

NBC system maintenance procedures require at least two personnel due to risk of medical emergency from possible exposure to NBC agents. Maintenance must be performed by properly trained, authorized personnel with proper safety equipment and protective clothing. Make sure batteries are disconnected and

WARNING SUMMARY – (Continued)

area is well ventilated. Do not smoke or allow open flame near vehicle. Never operate system with cover or panel removed. Failure to comply may result in serious injury or death to personnel.

WARNING

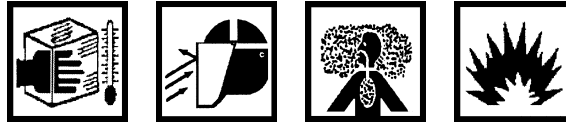

REFRIGERANT

Do not expose refrigerant containers, empty or full, to open flames or temperatures above 125°F (52°C). Do not discard empty containers where they may be subject to heat from a trash burner; containers may explode. Failure to comply may result in damage to equipment and serious injury or death to personnel.

The temperature of liquid refrigerant is -20°F (-29°C). Wear full face shield, protective rubberized gloves, and protective clothing when working with refrigerant. If refrigerant contacts skin, remove all contaminated clothing. Treat skin as though it were frostbitten or frozen and seek immediate medical attention. If refrigerant contacts eyes, do not rub them. Flush eyes with cold water for at least 15 minutes to gradually increase temperature above freezing point. Seek immediate medical attention. Failure to comply may result in serious injury or death to personnel.

Refrigerant becomes a poisonous gas in the presence of heat. Do not smoke or allow any type of flame in immediate area while servicing air conditioning system. Never weld, solder, steam clean, or use excessive heat on any part of the air conditioning system while charged/pressurized. Failure to comply may result in damage to equipment and serious injury or death to personnel.

R-134a refrigerant must not be mixed with air and then pressurized. When mixed with large quantities of air and pressurized, R-134a becomes combustible. Failure to comply may result in damage to equipment and environment, and serious injury or death to personnel.

Refrigerant evaporates very quickly and may displace oxygen surrounding work area, especially in a small or enclosed area. This can cause suffocation or brain damage. If leak occurs, avoid breathing refrigerant vapor and thoroughly ventilate area before continuing service. If personnel breathe refrigerant vapors, obtain immediate medical assistance. Failure to comply may result in serious injury or death to personnel.

Federal and state laws require that refrigerant be recovered and recycled. Refrigerant must be recovered from system with authorized recommended equipment before any work can be performed on unit. Always use approved recycling equipment to prevent accidental discharge. Failure to comply may result in damage to equipment and environment, and serious injury or death to personnel.

WARNING



HVAC SYSTEM

Do not check compressor oil level when HVAC system is charged with refrigerant. Never open the high side hand valve of the manifold gauge set while HVAC system is operating. If hot, high pressure refrigerant is forced through gauge to refrigerant supply cylinder, which could rupture. Do not disconnect HVAC lines from compressor. Release of refrigerant may cause damage to equipment or environment and serious injury or death to personnel.

Do not use parts other than those specified for the system being serviced. Failure to comply may result in damage to equipment and serious injury or death to personnel.

Accidental or intentional introduction of liquid contaminants into the environment is a violation of state, federal, and military regulations. Store, install, and dispose of containers in accordance with standard operating procedures.

WARNING SUMMARY – (Continued)

Refer to Army POL (para. 1-8) for information concerning storage, use, and disposal of liquid contaminants. Failure to comply may result in damage to environment and serious injury or death to personnel.

WARNING



SILICONE GASKET MATERIAL

Silicone gasket material emits a small amount of acid vapor. Ensure work area is well ventilated. Read and carefully follow manufacturer's instructions before use. If silicone gasket material contacts eyes, follow manufacturer's emergency procedures. Seek medical assistance as soon as possible. Failure to comply may result in serious injury to personnel.

WARNING



SILICONE GREASE

Silicone grease is harmful to skin and eyes. If silicone grease contacts eyes, rinse thoroughly and contact physician if irritation persists. If skin is contacted, wash thoroughly with soap and water. Failure to comply may result in serious injury to personnel.

WARNING



THREAD SEALING COMPOUND

Thread sealing compound is harmful to skin and eyes. If thread sealing compound contacts eyes, rinse thoroughly and contact physician if irritation persists. If skin is contacted, wash thoroughly with soap and water. Failure to comply may result in serious injury to personnel.

LIST OF EFFECTIVE PAGES/WORK PACKAGES

NOTE:

Zero in the "Change No." column indicates an original page or work package.

Date of issue for original manual is:

Original 19 November 2012

THE TOTAL NUMBER OF FRONT AND REAR PAGES IS 80, AND THE TOTAL NUMBER OF WORK PACKAGES IS 187, CONSISTING OF THE FOLLOWING:

Page/WP No.	Change No.	Page/WP No.	Change No.
Front Cover.....	0	WP 0644 (2 pgs).....	0
Warning summary (22 pgs)	0	WP 0645 (6 pgs).....	0
i-xlviii.....	0	WP 0646 (8 pgs).....	0
VOLUME 5	0	WP 0647 (10 pgs).....	0
Chapter 9 title page	0	WP 0648 (4 pgs).....	0
WP 0609 (12 pgs).....	0	WP 0649 (4 pgs).....	0
WP 0610 (2 pgs).....	0	WP 0650 (2 pgs).....	0
WP 0611 (4 pgs).....	0	WP 0651 (4 pgs).....	0
WP 0612 (4 pgs).....	0	WP 0652 (4 pgs).....	0
WP 0613 (6 pgs).....	0	WP 0653 (4 pgs).....	0
WP 0614 (4 pgs).....	0	WP 0654 (4 pgs).....	0
WP 0615 (6 pgs).....	0	WP 0655 (6 pgs).....	0
WP 0616 (8 pgs).....	0	WP 0656 (6 pgs).....	0
WP 0617 (8 pgs).....	0	WP 0657 (6 pgs).....	0
WP 0618 (4 pgs).....	0	WP 0658 (6 pgs).....	0
WP 0619 (6 pgs).....	0	WP 0659 (4 pgs).....	0
WP 0620 (6 pgs).....	0	WP 0660 (4 pgs).....	0
WP 0621 (6 pgs).....	0	WP 0661 (4 pgs).....	0
WP 0622 (4 pgs).....	0	WP 0662 (4 pgs).....	0
WP 0623 (16 pgs).....	0	WP 0663 (12 pgs).....	0
WP 0624 (14 pgs).....	0	WP 0664 (4 pgs).....	0
WP 0625 (12 pgs).....	0	WP 0665 (8 pgs).....	0
WP 0626 (4 pgs).....	0	WP 0666 (12 pgs).....	0
WP 0627 (4 pgs).....	0	WP 0667 (14 pgs).....	0
WP 0628 (6 pgs).....	0	WP 0668 (12 pgs).....	0
WP 0629 (4 pgs).....	0	WP 0669 (6 pgs).....	0
WP 0630 (6 pgs).....	0	WP 0670 (6 pgs).....	0
WP 0631 (4 pgs).....	0	WP 0671 (2 pgs).....	0
WP 0632 (2 pgs).....	0	WP 0672 (2 pgs).....	0
WP 0633 (4 pgs).....	0	WP 0673 (6 pgs).....	0
WP 0634 (4 pgs).....	0	WP 0674 (2 pgs).....	0
WP 0635 (4 pgs).....	0	WP 0675 (2 pgs).....	0
WP 0636 (6 pgs).....	0	WP 0676 (6 pgs).....	0
WP 0637 (8 pgs).....	0	WP 0677 (4 pgs).....	0
WP 0638 (6 pgs).....	0	WP 0678 (8 pgs).....	0
WP 0639 (12 pgs).....	0	WP 0679 (6 pgs).....	0
WP 0640 (2 pgs).....	0	WP 0680 (4 pgs).....	0
WP 0641 (8 pgs).....	0	WP 0681 (6 pgs).....	0
WP 0642 (4 pgs).....	0	WP 0682 (2 pgs).....	0
WP 0643 (2 pgs).....	0	WP 0683 (12 pgs).....	0

LIST OF EFFECTIVE PAGES/WORK PACKAGES

WP 0684 (6 pgs).....	0	WP 0737 (4 pgs).....	0
WP 0685 (6 pgs).....	0	WP 0738 (4 pgs).....	0
WP 0686 (6 pgs).....	0	WP 0739 (8 pgs).....	0
WP 0687 (6 pgs).....	0	WP 0740 (10 pgs).....	0
WP 0688 (4 pgs).....	0	WP 0741 (4 pgs).....	0
WP 0689 (8 pgs).....	0	WP 0742 (2 pgs).....	0
WP 0690 (4 pgs).....	0	WP 0743 (4 pgs).....	0
WP 0691 (4 pgs).....	0	WP 0744 (4 pgs).....	0
WP 0692 (8 pgs).....	0	WP 0745 (6 pgs).....	0
WP 0693 (4 pgs).....	0	WP 0746 (4 pgs).....	0
WP 0694 (4 pgs).....	0	WP 0747 (4 pgs).....	0
WP 0695 (4 pgs).....	0	WP 0748 (4 pgs).....	0
WP 0696 (10 pgs).....	0	WP 0749 (4 pgs).....	0
WP 0697 (10 pgs).....	0	WP 0750 (4 pgs).....	0
WP 0698 (8 pgs).....	0	WP 0751 (4 pgs).....	0
WP 0699 (4 pgs).....	0	WP 0752 (8 pgs).....	0
WP 0700 (6 pgs).....	0	WP 0753 (6 pgs).....	0
WP 0701 (12 pgs).....	0	WP 0754 (4 pgs).....	0
WP 0702 (6 pgs).....	0	WP 0755 (2 pgs).....	0
WP 0703 (4 pgs).....	0	WP 0756 (4 pgs).....	0
WP 0704 (6 pgs).....	0	WP 0757 (6 pgs).....	0
WP 0705 (6 pgs).....	0	WP 0758 (14 pgs).....	0
WP 0706 (4 pgs).....	0	WP 0759 (8 pgs).....	0
WP 0707 (10 pgs).....	0	WP 0760 (10 pgs).....	0
WP 0708 (8 pgs).....	0	WP 0761 (12 pgs).....	0
WP 0709 (8 pgs).....	0	WP 0762 (6 pgs).....	0
WP 0710 (12 pgs).....	0	WP 0763 (6 pgs).....	0
WP 0711 (6 pgs).....	0	WP 0764 (4 pgs).....	0
WP 0712 (8 pgs).....	0	WP 0765 (2 pgs).....	0
WP 0713 (12 pgs).....	0	WP 0766 (6 pgs).....	0
WP 0714 (10 pgs).....	0	WP 0767 (2 pgs).....	0
WP 0715 (10 pgs).....	0	WP 0768 (4 pgs).....	0
WP 0716 (8 pgs).....	0	WP 0769 (6 pgs).....	0
WP 0717 (8 pgs).....	0	WP 0770 (6 pgs).....	0
WP 0718 (4 pgs).....	0	WP 0771 (6 pgs).....	0
WP 0719 (4 pgs).....	0	WP 0772 (4 pgs).....	0
WP 0720 (2 pgs).....	0	WP 0773 (4 pgs).....	0
WP 0721 (6 pgs).....	0	WP 0774 (10 pgs).....	0
WP 0722 (6 pgs).....	0	WP 0775 (6 pgs).....	0
WP 0723 (8 pgs).....	0	WP 0776 (10 pgs).....	0
WP 0724 (6 pgs).....	0	WP 0777 (8 pgs).....	0
WP 0725 (6 pgs).....	0	WP 0778 (4 pgs).....	0
WP 0726 (6 pgs).....	0	WP 0779 (6 pgs).....	0
WP 0727 (8 pgs).....	0	WP 0780 (6 pgs).....	0
WP 0728 (6 pgs).....	0	WP 0781 (2 pgs).....	0
WP 0729 (6 pgs).....	0	WP 0782 (6 pgs).....	0
WP 0730 (6 pgs).....	0	WP 0783 (20 pgs).....	0
WP 0731 (10 pgs).....	0	WP 0784 (4 pgs).....	0
WP 0732 (10 pgs).....	0	WP 0785 (26 pgs).....	0
WP 0733 (6 pgs).....	0	WP 0786 (4 pgs).....	0
WP 0734 (12 pgs).....	0	WP 0787 (8 pgs).....	0
WP 0735 (4 pgs).....	0	WP 0788 (12 pgs).....	0
WP 0736 (2 pgs).....	0	WP 0789 (76 pgs).....	0

LIST OF EFFECTIVE PAGES/WORK PACKAGES

WP 0790 (80 pgs).....	0	WP 0795 (8 pgs).....	0
WP 0791 (2 pgs).....	0	WP 0796 (8 pgs).....	0
WP 0792 (4 pgs).....	0	Back cover.....	0
WP 0793 (46 pgs).....	0		
WP 0794 (4 pgs).....	0		

HEADQUARTERS, DEPARTMENTS OF THE ARMY AND AIR FORCE
WASHINGTON, D.C., 19 NOVEMBER 2012

TECHNICAL MANUAL
FIELD MAINTENANCE MANUAL
FOR
MINE RESISTANT AMBUSH PROTECTED (MRAP)

M1224
(NSN 2355-01-553-4634) (EIC 1XF)

M1224A1
(NSN 2355-01-561-0281) (EIC 1XM)

REPORTING ERRORS AND RECOMMENDING IMPROVEMENTS

(A) Army - You can help improve this publication. If you find any errors, or if you would like to recommend any improvements to the procedures in this publication, please let us know. The preferred method is to submit your DA Form 2028 (Recommended Changes to Publications and Blank Forms) through the Internet, on the TACOM unique Logistics Support Applications (TULSA) Web site. The Internet address is <https://tulsa.tacom.army.mil>. Access to all applications requires CAC authentication, and you must complete the Access Request form the first time you use it. The DA Form 2028 is located under the TULSA Applications on the left-hand navigation bar. Fill out the form and click on SUBMIT. Using this form on the TULSA Web site will enable us to respond more quickly to your comments and to better manage the DA Form 2028 program. You may also mail, e-mail, or fax your comments or DA Form 2028 directly to the U.S. Army TACOM Life Cycle Management Command. The postal mail address is U.S. Army TACOM Life Cycle Management Command, ATTN: AMSTA-LCL-MPP/ TECH PUBS, MS 727, 6501 East 11 Mile Road, Warren, MI 48397-5000. The e-mail address is tacomlcmc.daform2028@us.army.mil. The fax number is DSN 786-1856 or Commercial (586) 282-1856. A reply will be furnished to you.

(F) Air Force - By Air Force AFTO Form 22 directly to Warner Robins, Tech Data Home office, 584 CBSS/GBHDE, 480 Richard Ray Blvd Ste 200, Robins AFB GA 31098-1640. You may also send in your recommended changes via electronic mail or by fax. Our fax number is DSN 472-3104 or Commercial (478) 222-3104. Forward all electronic AFTO 22 submissions to the following mail account: Robins.ce.afto22@robins.af.mil. Recommendations concerning changes to this manual shall be submitted in accordance with TO 00-5-1-WA-1.

DISCLOSURE NOTICE – This information is furnished upon the condition that it will not be released to another nation without the specific authority of the Department of the Army of the United States, that it will be used for military purposes only, that individual or corporate rights originating in the information, whether patented or not, will be respected, that the recipient will report promptly to the United States, any known or suspected compromise, and that the information will be provided substantially the same degree of security afforded it by the Department of Defense of the United States. Also, regardless of any other markings on the document, it will not be downgraded or declassified without written approval of the originating United States agency.

DISTRIBUTION STATEMENT C – Distribution authorized to U.S. Government Agencies and their contractors only for Specific Authority as determined on 01 August 2012. Other requests for this document shall be referred to TACOM Life Cycle Management Command, ATTN: AMSTA-LCC-MMK/TECH PUBS, Warren, MI 48397-5000.

WARNING – This document contains technical data whose export is restricted by the Arms Export Control Act (Title 22, U.S.C., Sec 2751, et seq) or the Export Administration Act of 1979, as amended, Title 50, U.S.C., App. 2401 et seq. Violations of these export laws are subject to severe criminal penalties. Disseminate in accordance with provisions of DoD Directive 5230.25.

DESTRUCTION NOTICE – Destroy by any method that will prevent disclosure of contents or reconstruction of contents.

TABLE OF CONTENTS

Page No.
WP Sequence No.

VOLUME 5

CHAPTER 9. MAINTENANCE INSTRUCTIONS, VOL 5

DOOR ARMOR PANEL REMOVAL AND INSTALLATION, Vol 5	WP 0609
Figure 1. Door Handle Trim., Vol 5	WP 0609
Figure 2. Kick Panel Power Mirror Harness Connector., Vol 5.	WP 0609
Figure 3. Power Mirror Harness Connector., Vol 5.	WP 0609
Figure 4. Door Armor., Vol 5	WP 0609
Figure 5. Door Window Riot Guard., Vol 5	WP 0609
Figure 6. Mirror Mounting Plate., Vol 5.	WP 0609
Figure 7. Mirror Harness., Vol 5.	WP 0609
Figure 8. Door Window Riot Guard., Vol 5	WP 0609
Figure 9. Mirror Harness., Vol 5.	WP 0609
Figure 10. Mirror Mounting Plate., Vol 5	WP 0609
Figure 11. Door Armor., Vol 5.	WP 0609
Figure 12. Power Mirror Harness Connector., Vol 5	WP 0609
Figure 13. Kick Panel Power Mirror Harness Connector., Vol 5	WP 0609
Figure 14. Door Handle Trim., Vol 5	WP 0609
DOOR WINDOW RIOT GUARD REMOVAL AND INSTALLATION, Vol 5	WP 0610
Figure 1. Door Window Riot Guard., Vol 5	WP 0610
UPPER CABIN DOOR LOCK, SPACER, AND BRACKET REMOVAL AND INSTALLATION, Vol 5	WP 0611
Figure 1. Upper Cabin Door Lock, Spacer, and Bracket Removal., Vol 5	WP 0611
Figure 2. Upper Cabin Door Lock, Spacer, and Bracket Installation., Vol 5	WP 0611
LOWER CABIN DOOR LOCK, SPACER, AND BRACKET REMOVAL AND INSTALLATION, Vol 5	WP 0612
Figure 1. Lower Cabin Door Lock Retainer Clip Removal., Vol 5	WP 0612
Figure 2. Lower Cabin Door Lock, Spacer, and Bracket Removal., Vol 5	WP 0612
Figure 3. Lower Cabin Door Lock, Spacer, and Bracket Installation., Vol 5	WP 0612
Figure 4. Lower Cabin Door Lock Retainer Clip Installation., Vol 5.	WP 0612
CABIN DOOR STRIKER AND CABIN DOOR CHECK STOP ASSEMBLIES REMOVAL AND INSTALLATION, Vol 5	WP 0613
Figure 1. Cabin Door Striker Tapping Plate Cover Removal., Vol 5	WP 0613
Figure 2. Cabin Door Striker Removal., Vol 5.	WP 0613
Figure 3. Door Check Stop Removal., Vol 5	WP 0613
Figure 4. Door Check Stop Installation., Vol 5	WP 0613
Figure 5. Cabin Door Striker Installation., Vol 5	WP 0613
Figure 6. Cabin Door Striker Tapping Plate Cover Installation., Vol 5.	WP 0613
CABIN DOOR SEAL REMOVAL AND INSTALLATION, Vol 5	WP 0614
Figure 1. Cabin Door Seal Removal., Vol 5.	WP 0614
Figure 2. Cabin Door Seal Application., Vol 5.	WP 0614
CABIN DOOR LINKAGE INSPECTION AND ADJUSTMENT PROCEDURE (LOWER INTERIOR COMBAT DOOR LOCK-TYPE), Vol 5.	WP 0615
Figure 1. Inner Door Latch Handle Shaft in Neutral Position., Vol 5	WP 0615
Figure 2. Air Valve Linkage Centered on Latch Handle Shaft., Vol 5	WP 0615
Figure 3. Air Valve Perpendicular to Air Valve Module Face., Vol 5	WP 0615
Figure 4. Door Latches Set in Closed Position., Vol 5	WP 0615
Figure 5. Door Speed Stop Lock Nut and Adjustment Bolt., Vol 5	WP 0615

TABLE OF CONTENTS – (Continued)

	Page No.
	WP Sequence No.
CABIN DOOR LINKAGE INSPECTION AND ADJUSTMENT PROCEDURE (UPPER COMBAT DOOR LOCK TYPE), Vol 5	WP 0616
Figure 1. Inner Door Latch Handle Shaft in Neutral Position., Vol 5	WP 0616
Figure 2. Air Valve Linkage Adjustment., Vol 5	WP 0616
Figure 3. Door Latch Linkage Adjustment., Vol 5	WP 0616
Figure 4. Cylinder Lock Shaft Linkage Adjustment., Vol 5	WP 0616
Figure 5. Door Latch Linkage., Vol 5	WP 0616
Figure 6. Lower Door Latch Adjustment., Vol 5	WP 0616
Figure 7. Upper Door Latch Linkage Adjustment., Vol 5	WP 0616
Figure 8. Door Speed Stop Adjusting Bolts., Vol 5.	WP 0616
DUAL-PNEUMATIC DOOR ACTUATOR REMOVAL AND INSTALLATION, Vol 5	WP 0617
Figure 1. Door Actuator Air Line and Pin., Vol 5	WP 0617
Figure 2. Door Actuator Latch Linkage Rod., Vol 5	WP 0617
Figure 3. Outside Mirror Harness., Vol 5	WP 0617
Figure 4. Combat Lock Linkage., Vol 5	WP 0617
Figure 5. Door Actuator., Vol 5	WP 0617
Figure 6. Door Actuator., Vol 5	WP 0617
Figure 7. Door Actuator Installation., Vol 5	WP 0617
Figure 8. Pneumatic Door Actuator Bolts., Vol 5	WP 0617
Figure 9. Combat Lock Linkage., Vol 5	WP 0617
Figure 10. Outside Mirror Harness., Vol 5	WP 0617
Figure 11. Door Actuator Latch Linkage Rod., Vol 5	WP 0617
Figure 12. Door Actuator Air Line and Pin., Vol 5	WP 0617
CABIN DOOR ASSIST SYSTEM ACTUATOR AIR LINE TUBING REMOVAL AND INSTALLATION, Vol 5	WP 0618
Figure 1. Actuator Air Lines., Vol 5	WP 0618
Figure 2. Tubing Replacement., Vol 5	WP 0618
LEFT DOOR AIR SUPPLY LINE REMOVAL AND INSTALLATION, Vol 5	WP 0619
Figure 1. Supply Air Line Tubing., Vol 5	WP 0619
Figure 2. Supply Air Line Tubing Retainers., Vol 5.	WP 0619
Figure 3. Supply Air Line Tubing Tee., Vol 5	WP 0619
Figure 4. Air Line Tubing Tee., Vol 5.	WP 0619
Figure 5. Supply Air Line Tubing Retainers., Vol 5.	WP 0619
Figure 6. Door Actuator., Vol 5	WP 0619
RIGHT CABIN DOOR ASSIST SYSTEM SUPPLY AIR LINE TUBING REMOVAL AND INSTALLATION, Vol 5	WP 0620
Figure 1. Supply Air Line Tubing., Vol 5	WP 0620
Figure 2. Supply Air Line Tubing Retainers., Vol 5.	WP 0620
Figure 3. Follow Air Line To Left Side Of Vehicle., Vol 5	WP 0620
Figure 4. Supply Air Line Tubing Tee, Located On Left Side Of Vehicle., Vol 5	WP 0620
Figure 5. Air Line Tubing Tee., Vol 5.	WP 0620
Figure 6. Supply Air Line Tubing Retainers., Vol 5.	WP 0620
Figure 7. Door Actuator., Vol 5	WP 0620
CABIN DOOR ASSIST SYSTEM SUPPLY PASS-THROUGH AIR LINE TUBING REMOVAL AND INSTALLATION, Vol 5	WP 0621
Figure 1. Door Actuator Air Line Tube., Vol 5	WP 0621
Figure 2. Exterior Air Lines., Vol 5.	WP 0621
Figure 3. Air Line Union., Vol 5	WP 0621
Figure 4. Air Line Union Installation., Vol 5	WP 0621
Figure 5. Exterior Air Lines., Vol 5.	WP 0621
Figure 6. Door Actuator Air Line Tube., Vol 5	WP 0621

TABLE OF CONTENTS – (Continued)

	Page No.
	<u>WP Sequence No.</u>
CABIN DOOR ASSIST SYSTEM SUPPLY AIR LINE TUBING REMOVAL AND INSTALLATION, Vol 5	WP 0622
Figure 1. Primary and Supply Tanks., Vol 5.	WP 0622
Figure 2. Air Line Union., Vol 5	WP 0622
Figure 3. Supply Air Line Tubing., Vol 5	WP 0622
Figure 4. Primary and Supply Tanks., Vol 5.	WP 0622
CABIN DOOR EXTERIOR HANDLE ASSEMBLY REMOVAL AND INSTALLATION (SINGLE-AND DUAL-CYLINDER), Vol 5	WP 0623
Figure 1. Inner Door Handle Shaft Cover Plate Removal., Vol 5.	WP 0623
Figure 2. Upper Hex Bolt Removal from Inner Shaft Lock Plate Bracket., Vol 5	WP 0623
Figure 3. Combat Lock Shaft Lever and Vertical Shaft Lever Removal from Combat Lock Bell Crank., Vol 5.	WP 0623
Figure 4. Retaining Clips Removal from Door Linkage Rods., Vol 5	WP 0623
Figure 5. Retaining Clip Removed from Lower Linkage Rod and Door Latch Plate., Vol 5.	WP 0623
Figure 6. Interior Handle Socket Head Screws Removal., Vol 5	WP 0623
Figure 7. Exterior Door Handle Positioned for Removal., Vol 5	WP 0623
Figure 8. Interior Door Handle Assembly Partial Removal., Vol 5	WP 0623
Figure 9. Cabin Door Interior Handle Assembly Removal from Inner Door., Vol 5	WP 0623
Figure 10. Cabin Door Interior Handle Assembly., Vol 5	WP 0623
Figure 11. Setscrew Loosened on Exterior Handle., Vol 5	WP 0623
Figure 12. Exterior Handle Removed from Interior Handle Assembly., Vol 5.	WP 0623
Figure 13. Exterior Handle Installation on Interior Handle Shaft Assembly., Vol 5	WP 0623
Figure 14. Interior Handle Shaft Assembly Installation on Inner Door Frame., Vol 5	WP 0623
Figure 15. New Door Exterior Handle Installation., Vol 5	WP 0623
Figure 16. Door Interior Handle Shaft Assembly Partial Installation., Vol 5	WP 0623
Figure 17. Door Interior Handle Assembly Secured to Inner Door., Vol 5	WP 0623
Figure 18. Retaining Clips Installed on Linkage Rods., Vol 5	WP 0623
Figure 19. Combat Shaft Lever and Vertical Lever Installed on Bell Crank., Vol 5	WP 0623
Figure 20. Hex Bolts Installed on Inner Shaft Lock Plate Bracket., Vol 5	WP 0623
Figure 21. Inner Door Handle Shaft Cover Plate Installation., Vol 5	WP 0623
CABIN DOOR INTERIOR HANDLE ASSEMBLY REMOVAL AND INSTALLATION (SINGLE-PISTON, LOWER COMBAT DOOR LOCK-TYPE), Vol 5	WP 0624
Figure 1. Inner Door Handle Shaft Cover Plate., Vol 5	WP 0624
Figure 2. Upper Hex Bolt., Vol 5	WP 0624
Figure 3. Combat Lock Shaft Lever and Vertical Shaft Lever., Vol 5	WP 0624
Figure 4. Retaining Clips and Door Linkage Rods., Vol 5.	WP 0624
Figure 5. Cabin Door Interior Handle Socket-Head Screws., Vol 5.	WP 0624
Figure 6. Cabin Door Interior Handle Assembly., Vol 5	WP 0624
Figure 7. Cabin Door Interior Handle Assembly., Vol 5	WP 0624
Figure 8. Cabin Door Interior Handle., Vol 5	WP 0624
Figure 9. Cabin Door Interior Handle., Vol 5	WP 0624
Figure 10. Cabin Door Interior Handle Assembly., Vol 5	WP 0624
Figure 11. Retaining Clips and Door Linkage Rods., Vol 5	WP 0624
Figure 12. Combat Lock Shaft Lever and Vertical Shaft Lever to Combat Lock Bellcrank., Vol 5	WP 0624
Figure 13. Hex Bolts Installed on Inner Shaft Lockplate Bracket., Vol 5.	WP 0624
Figure 14. Inner Door Handle Shaft Cover Plate., Vol 5	WP 0624

TABLE OF CONTENTS – (Continued)

	Page No.
	WP Sequence No.
CABIN DOOR INTERIOR HANDLE ASSEMBLY REMOVAL AND INSTALLATION (DUAL PISTON UPPER INTERIOR COMBAT DOOR LOCK-TYPE), Vol 5	WP 0625
Figure 1. Inner Door Handle Shaft Cover Plate Removal., Vol 5	WP 0625
Figure 2. Upper Hex Bolt Removal from Inner Shaft Lockplate Bracket., Vol 5	WP 0625
Figure 3. Combat Lock Shaft Lever and Vertical Shaft Lever Removal from Combat Lock Bellcrank., Vol 5	WP 0625
Figure 4. Retaining Clips, Springs, and Door Linkage Rods Removal., Vol 5	WP 0625
Figure 5. Cabin Door Interior Handle Assembly Removal., Vol 5	WP 0625
Figure 6. Cabin Door Interior Handle Assembly Removed., Vol 5	WP 0625
Figure 7. Cabin Door Interior Handle Disassembly., Vol 5	WP 0625
Figure 8. Cabin Door Interior Handle Assembly., Vol 5	WP 0625
Figure 9. Cabin Door Interior Handle Assembly Installation., Vol 5	WP 0625
Figure 10. Retaining Clips, Springs, and Door Linkage Rods Installation., Vol 5	WP 0625
Figure 11. Combat Lock Shaft Lever and Vertical Shaft Lever Installed on Bellcrank., Vol 5	WP 0625
Figure 12. Hex Bolts Installed on Inner Shaft Lockplate Bracket., Vol 5	WP 0625
Figure 13. Inner Door Handle Shaft Cover Plate Installation., Vol 5	WP 0625
CABIN DOOR TRIM PANEL REMOVAL AND INSTALLATION (ONE-PIECE, LOWER COMBAT DOOR LOCK-TYPE), Vol 5	WP 0626
Figure 1. Inside Door Combat Lock Handle Removal., Vol 5	WP 0626
Figure 2. Cabin Door Trim Panel Fasteners Removal., Vol 5	WP 0626
Figure 3. Cabin Door Trim Panel Fasteners Installation., Vol 5	WP 0626
Figure 4. Door Interior Combat Lock Handle Installation., Vol 5	WP 0626
CABIN DOOR TRIM PANEL REMOVAL AND INSTALLATION (TWO-PIECE, UPPER COMBAT DOOR LOCK TYPE), Vol 5	WP 0627
Figure 1. Cabin Door Trim Panel Fasteners Removal., Vol 5	WP 0627
Figure 2. Cabin Door Trim Panel Fasteners Installation., Vol 5	WP 0627
CABIN DOOR COMBAT LOCK ASSEMBLY REMOVAL AND INSTALLATION, Vol 5	WP 0628
Figure 1. Cabin Door Combat Lock Removal., Vol 5	WP 0628
Figure 2. Combat Lock Shaft in Near-Vertical Position., Vol 5	WP 0628
Figure 3. Door Combat Lock Assembly Installation., Vol 5	WP 0628
EXTERIOR BODY ARMOR RIGHT FRONT PANEL REMOVAL AND INSTALLATION, Vol 5	WP 0629
Figure 1. Body Armor Right Front Panel., Vol 5	WP 0629
Figure 2. Handrail and Door Grab Handle., Vol 5	WP 0629
Figure 3. Handrail and Door Grab Handle., Vol 5	WP 0629
Figure 4. Body Armor Right Front Panel., Vol 5	WP 0629
EXTERIOR BODY ARMOR MIDDLE REAR PANEL REMOVAL AND INSTALLATION, Vol 5	WP 0630
Figure 1. Body Armor Middle Rear Panel., Vol 5	WP 0630
Figure 2. Hand Rail., Vol 5	WP 0630
Figure 3. Hand Rail., Vol 5	WP 0630
Figure 4. Body Armor Middle Rear Panel., Vol 5	WP 0630
EXTERIOR BODY ARMOR REAR PANEL REMOVAL AND INSTALLATION, Vol 5	WP 0631
Figure 1. Body Armor Rear Panel., Vol 5	WP 0631
Figure 2. Body Armor Rear Panel., Vol 5	WP 0631
EXTERIOR BODY ARMOR RIOT GUARD REMOVAL AND INSTALLATION, Vol 5	WP 0632
Figure 1. Exterior Body Armor Riot Guard., Vol 5	WP 0632
Figure 2. Exterior Body Armor Riot Guard., Vol 5	WP 0632

TABLE OF CONTENTS – (Continued)

	Page No.
	WP Sequence No.
EXTERIOR BODY ARMOR LEFT FRONT PANEL REMOVAL AND INSTALLATION, Vol 5 . . .	WP 0633
Figure 1. Body Armor Left Front Panel., Vol 5	WP 0633
Figure 2. Door Grab Handle., Vol 5	WP 0633
Figure 3. Door Grab Handle., Vol 5	WP 0633
Figure 4. Body Armor Left Front Panel., Vol 5	WP 0633
EXTERIOR BODY ARMOR LEFT MIDDLE FRONT PANEL REMOVAL AND INSTALLATION, Vol 5	WP 0634
Figure 1. Body Armor Left Middle Front Panel., Vol 5	WP 0634
Figure 2. Hand Rail., Vol 5	WP 0634
Figure 3. Hand Rail., Vol 5	WP 0634
Figure 4. Body Armor Left Middle Front Panel., Vol 5	WP 0634
EXTERIOR BODY ARMOR RIGHT MIDDLE FRONT PANEL REMOVAL AND INSTALLATION, Vol 5	WP 0635
Figure 1. Body Armor Right Middle Front Panel., Vol 5	WP 0635
Figure 2. Hand Rail., Vol 5	WP 0635
Figure 3. Hand Rail., Vol 5	WP 0635
Figure 4. Body Armor Right Middle Front Panel., Vol 5	WP 0635
REAR DOOR/RAMP SEAL REMOVAL AND INSTALLATION, Vol 5	WP 0636
Figure 1. Rear Door/Ramp Assembly Lowered., Vol 5	WP 0636
Figure 2. Rear Door/Ramp Seal Seam Adhesive Cut., Vol 5	WP 0636
Figure 3. Rear Door/Ramp Seal Removal., Vol 5	WP 0636
Figure 4. Rear Door/Ramp Seal Installation., Vol 5	WP 0636
Figure 5. Rear Door/Ramp Seal Seam Adhesive Application., Vol 5	WP 0636
Figure 6. Rear Door/Ramp Assembly Raised., Vol 5	WP 0636
BODY ARMOR REAR WALL, RIOT GUARD, AND BRACKET REMOVAL AND INSTALLATION, Vol 5	WP 0637
Figure 1. Rear Ladder and Fuel/Water Cans., Vol 5	WP 0637
Figure 2. Upper Light Bar, Above Rear Door., Vol 5	WP 0637
Figure 3. Rear Wall Body Armor., Vol 5	WP 0637
Figure 4. Rear Window Riot Guard., Vol 5	WP 0637
Figure 5. Fuel/Water Can Mount., Vol 5	WP 0637
Figure 6. Fuel/Water Mount., Vol 5	WP 0637
Figure 7. Rear Window Riot Guard., Vol 5	WP 0637
Figure 8. Rear Wall Body Armor., Vol 5	WP 0637
Figure 9. Upper Light Bar, Above Rear Door., Vol 5	WP 0637
Figure 10. Rear Ladder., Vol 5	WP 0637
REAR WALL OVERLAP REMOVAL AND INSTALLATION, Vol 5	WP 0638
Figure 1. Rear Sheet Metal Panel., Vol 5	WP 0638
Figure 2. Rear Sheet Metal Panel., Vol 5	WP 0638
Figure 3. Trailer Electrical Socket., Vol 5	WP 0638
Figure 4. Rear Wall Overlap., Vol 5	WP 0638
Figure 5. Rear Wall Overlap Removed., Vol 5	WP 0638
Figure 6. Rear Wall Overlap Removed., Vol 5	WP 0638
Figure 7. Rear Wall Overlap., Vol 5	WP 0638
Figure 8. Rear Sheet Metal Panel., Vol 5	WP 0638
Figure 9. Trailer Electrical Socket., Vol 5	WP 0638
Figure 10. Rear Sheet Metal Panel., Vol 5	WP 0638

TABLE OF CONTENTS – (Continued)

	Page No.
	<u>WP Sequence No.</u>
REAR DOOR/RAMP REMOVAL AND INSTALLATION, Vol 5	WP 0639
Figure 1. Rear Door/Ramp Assembly Lowered., Vol 5	WP 0639
Figure 2. Loop Lifting Sling Around Door/Ramp Left Hinge., Vol 5	WP 0639
Figure 3. Loop Lifting Sling Around Door/Ramp Right Hinge., Vol 5	WP 0639
Figure 4. Loop Lifting Sling Around Door/Ramp Left Rear Mounting Boss., Vol 5	WP 0639
Figure 5. Loop Lifting Sling Around Door/Ramp Right Rear Mounting Boss., Vol 5	WP 0639
Figure 6. Route Ends of Slings Through a Fifth Sling., Vol 5	WP 0639
Figure 7. Locking Safety Pin Removed from Hydraulic Cylinder., Vol 5	WP 0639
Figure 8. Rear Door/Ramp Removed from Vehicle., Vol 5	WP 0639
Figure 9. Rear Door/Ramp Assembly Installed., Vol 5	WP 0639
Figure 10. Loop Lifting Sling Around Door/Ramp Right Hinge., Vol 5	WP 0639
Figure 11. Loop Lifting Sling Around Door/Ramp Right Hinge., Vol 5	WP 0639
Figure 12. Loop Lifting Sling Around Door/Ramp Right Hinge., Vol 5	WP 0639
Figure 13. Loop Lifting Sling Around Door/Ramp Right Hinge., Vol 5	WP 0639
Figure 14. Rear Door/Ramp Assembly Installed., Vol 5	WP 0639
Figure 15. Hydraulic Cylinder Secured with Locking Safety Pin., Vol 5	WP 0639
Figure 16. Bottom Step Adjusted with Spacers., Vol 5	WP 0639
BOTTOM RAMP STEP REMOVAL AND INSTALLATION, Vol 5	WP 0640
Figure 1. Bottom Ramp Step Removal from Ramp., Vol 5	WP 0640
Figure 2. Bottom Ramp Step Installation., Vol 5	WP 0640
REAR DOOR/RAMP LOCK ASSEMBLY REMOVAL AND INSTALLATION, Vol 5	WP 0641
Figure 1. Rear Door/Ramp Assembly Lowered., Vol 5	WP 0641
Figure 2. Right Side Shroud Cover Removal., Vol 5	WP 0641
Figure 3. Left Side Shroud Cover Removal., Vol 5	WP 0641
Figure 4. Coil Springs Removal from Door Lock Assembly., Vol 5	WP 0641
Figure 5. Rear Door Lock Assembly Mounting Brackets Removal., Vol 5	WP 0641
Figure 6. Rear Door Lock Assembly Removed from Vehicle., Vol 5	WP 0641
Figure 7. Rear Door Lock Assembly with Mounting Brackets Removed., Vol 5	WP 0641
Figure 8. Mounting Brackets Installed on Rear Door Lock Assembly., Vol 5	WP 0641
Figure 9. Rear Door Lock Assembly Installed., Vol 5	WP 0641
Figure 10. Coil Springs Installed on Rear Door Lock Assembly and Roof-Mounted Brackets., Vol 5	WP 0641
Figure 11. Rear Door/Ramp Assembly Lowered., Vol 5	WP 0641
Figure 12. Right Side Shroud Cover Installed on Roof-Mounted Bracket., Vol 5	WP 0641
Figure 13. Left Side Shroud Cover Installed on Roof-Mounted Bracket., Vol 5	WP 0641
A-PILLAR COVER TRIM REMOVAL AND INSTALLATION, Vol 5	WP 0642
Figure 1. A-Pillar Cover Trim Bolts., Vol 5	WP 0642
Figure 2. A-Pillar Cover Trim., Vol 5	WP 0642
Figure 3. A-Pillar Cover Trim., Vol 5	WP 0642
Figure 4. A-Pillar Cover Trim Bolts., Vol 5	WP 0642
A-PILLAR ASSIST HANDLE REMOVAL AND INSTALLATION, Vol 5	WP 0643
Figure 1. A-Pillar Assist Handle Removal., Vol 5	WP 0643
Figure 2. A-Pillar Assist Handle Installation., Vol 5	WP 0643
SIDE COWL BODY ARMOR PANEL REMOVAL AND INSTALLATION, Vol 5	WP 0644
Figure 1. Side Cowl Body Armor Panel., Vol 5	WP 0644
Figure 2. Side Cowl Body Armor Panel., Vol 5	WP 0644

TABLE OF CONTENTS – (Continued)

	Page No.
	<u>WP Sequence No.</u>
WINDSHIELD ARMOR REMOVAL AND INSTALLATION, Vol 5	WP 0645
Figure 1. Antenna Brackets., Vol 5	WP 0645
Figure 2. Windshield Armor and Front Marker Bar., Vol 5.	WP 0645
Figure 3. Windshield Armor and Front Maker Bar., Vol 5	WP 0645
Figure 4. Antenna Brackets., Vol 5	WP 0645
DRIVER CONTROL MOUNTING (DCM) BRACKET ASSEMBLY EXTERIOR ARMOR REMOVAL AND INSTALLATION (WITHOUT FRONT ACCESS PANEL), Vol 5	WP 0646
Figure 1. DCM Right Side Exterior Armor Lower Bolt., Vol 5	WP 0646
Figure 2. DCM Right Side Exterior Armor Upper Bolts., Vol 5	WP 0646
Figure 3. DCM Left Side Exterior Armor Lower Bolt., Vol 5	WP 0646
Figure 4. DCM Left Side Exterior Armor Upper Inboard Bolts., Vol 5	WP 0646
Figure 5. DCM Left Side Exterior Armor Upper Outboard Bolt., Vol 5	WP 0646
Figure 6. DCM Left Side Exterior Armor Upper Outboard Bolt., Vol 5	WP 0646
Figure 7. DCM Left Side Exterior Armor Upper Inboard Bolts., Vol 5	WP 0646
Figure 8. DCM Left Side Exterior Armor Lower Bolt., Vol 5	WP 0646
Figure 9. DCM Right Side Exterior Armor Upper Bolts., Vol 5	WP 0646
Figure 10. DCM Right Side Exterior Armor Lower Bolt., Vol 5	WP 0646
DRIVER CONTROL MOUNTING (DCM) BRACKET ASSEMBLY EXTERIOR ARMOR REMOVAL AND INSTALLATION (WITH FRONT ACCESS PANEL), Vol 5	WP 0647
Figure 1. DCM Front Access Cover Armor Bolts., Vol 5	WP 0647
Figure 2. Air Lines and Steering Column Lockbolt., Vol 5.	WP 0647
Figure 3. Air Line., Vol 5	WP 0647
Figure 4. Exterior Armor Inboard Bolts., Vol 5.	WP 0647
Figure 5. Exterior Armor Outboard Lower Bolt., Vol 5	WP 0647
Figure 6. Exterior Armor Outboard Upper Bolt., Vol 5	WP 0647
Figure 7. Exterior Armor Bottom Cover., Vol 5	WP 0647
Figure 8. Exterior Armor Bottom Cover., Vol 5	WP 0647
Figure 9. Exterior Armor Outboard Upper Bolt., Vol 5	WP 0647
Figure 10. Exterior Armor Outboard Lower Bolt., Vol 5	WP 0647
Figure 11. Exterior Armor Inboard Bolts., Vol 5	WP 0647
Figure 12. Air Line., Vol 5	WP 0647
Figure 13. Air Lines and Steering Column Pinch Bolt., Vol 5	WP 0647
Figure 14. DCM Front Access Cover Armor Bolts., Vol 5	WP 0647
DRIVER CONTROL MOUNTING (DCM) BRACKET ASSEMBLY INTERIOR ARMOR REMOVAL AND INSTALLATION, Vol 5	WP 0648
Figure 1. Electronic System Controller (ESC) Module Connector., Vol 5	WP 0648
Figure 2. DCM Bracket Assembly Interior Armor., Vol 5	WP 0648
Figure 3. DCM Bracket Assembly Interior Armor., Vol 5	WP 0648
Figure 4. ESC Module Connector., Vol 5	WP 0648
ENGINE COVER REMOVAL AND INSTALLATION, Vol 5	WP 0649
Figure 1. Engine Cover Removal., Vol 5	WP 0649
Figure 2. Engine Cover Installation., Vol 5	WP 0649
COWL PANEL DRAIN TUBE REMOVAL AND INSTALLATION, Vol 5	WP 0650
Figure 1. Cowl Panel Drain Tube., Vol 5	WP 0650
MOTOR BAFFLE REMOVAL AND INSTALLATION, Vol 5	WP 0651
Figure 1. Motor Baffle and Flat Back Cowl Seal., Vol 5.	WP 0651
Figure 2. Motor Baffle and Flat Back Cowl Seal., Vol 5.	WP 0651
REAR WINDOW ARMOR GLASS REMOVAL AND INSTALLATION, Vol 5	WP 0652
Figure 1. Rear Window., Vol 5	WP 0652

TABLE OF CONTENTS – (Continued)

	Page No.
	WP Sequence No.
DOOR WINDOW ARMOR GLASS REMOVAL AND INSTALLATION, Vol 5	WP 0653
Figure 1. Door Window., Vol 5	WP 0653
Figure 2. Door Window., Vol 5	WP 0653
CABIN WINDOW ARMOR GLASS REMOVAL AND INSTALLATION, Vol 5	WP 0654
Figure 1. Cabin Window., Vol 5	WP 0654
WINDSHIELD ARMOR GLASS REMOVAL AND INSTALLATION, Vol 5	WP 0655
Figure 1. Heated Windshield Electrical Connectors., Vol 5	WP 0655
Figure 2. Windshield., Vol 5	WP 0655
Figure 3. Windshield Removal With Sling., Vol 5	WP 0655
Figure 4. Windshield., Vol 5	WP 0655
Figure 5. Heated Windshield Electrical Connectors., Vol 5	WP 0655
STEP AND BRACKETS REMOVAL AND INSTALLATION, Vol 5	WP 0656
Figure 1. Left Side Steps, Inside Bolt., Vol 5	WP 0656
Figure 2. Rear Bolts., Vol 5	WP 0656
Figure 3. Step., Vol 5	WP 0656
Figure 4. Front Bracket., Vol 5	WP 0656
Figure 5. Rear Bracket., Vol 5	WP 0656
Figure 6. Rear Bracket., Vol 5	WP 0656
Figure 7. Front Bracket., Vol 5	WP 0656
Figure 8. Step., Vol 5	WP 0656
Figure 9. Rear Bracket., Vol 5	WP 0656
Figure 10. Inside Bolt., Vol 5	WP 0656
FENDER AND REINFORCEMENT REMOVAL AND INSTALLATION, Vol 5	WP 0657
Figure 1. Fender and Latch., Vol 5	WP 0657
Figure 2. Fender and Bolts., Vol 5	WP 0657
Figure 3. Fender Reinforcement., Vol 5	WP 0657
Figure 4. Fender Reinforcement., Vol 5	WP 0657
Figure 5. Fender and Rivet., Vol 5	WP 0657
Figure 6. Fender and Bolts, Vol 5	WP 0657
FLOOR PANEL (FRONT) REMOVAL AND INSTALLATION, Vol 5	WP 0658
Figure 1. Front Floor Panel., Vol 5	WP 0658
Figure 2. Front Floor Panel Bottom., Vol 5	WP 0658
Figure 3. Front Floor Panel Bottom., Vol 5	WP 0658
Figure 4. Front Floor Panel., Vol 5	WP 0658
FLOOR PANEL (FRONT CENTER) REMOVAL AND INSTALLATION, Vol 5	WP 0659
Figure 1. Front Center Floor Panel., Vol 5	WP 0659
CENTER FLOOR PANEL REMOVAL AND INSTALLATION, Vol 5	WP 0660
Figure 1. Center Floor Panel., Vol 5	WP 0660
REAR CENTER FLOOR PANEL REMOVAL AND INSTALLATION, Vol 5	WP 0661
Figure 1. Rear Center Floor Panel., Vol 5	WP 0661
REAR FLOOR PANEL REMOVAL AND INSTALLATION, Vol 5	WP 0662
Figure 1. Rear Floor Panel., Vol 5	WP 0662

TABLE OF CONTENTS – (Continued)

	Page No.
	WP Sequence No.
DRIVER SEAT REMOVAL AND INSTALLATION, Vol 5	WP 0663
Figure 1. Rear Seat Hanger Safety Strap., Vol 5	WP 0663
Figure 2. Seat Upper Strap., Vol 5	WP 0663
Figure 3. Suspension Lever., Vol 5	WP 0663
Figure 4. Seat Suspension Lever Release., Vol 5	WP 0663
Figure 5. Seat Suspension Retainer., Vol 5	WP 0663
Figure 6. Floor Anchor., Vol 5	WP 0663
Figure 7. Driver Seat Rear Eyebolts., Vol 5	WP 0663
Figure 8. Driver Seat and Suspension., Vol 5	WP 0663
Figure 9. Driver Seat and Suspension., Vol 5	WP 0663
Figure 10. Driver Seat Rear Eyebolt., Vol 5	WP 0663
Figure 11. Floor Anchor., Vol 5	WP 0663
Figure 12. Seat Suspension Retainer., Vol 5	WP 0663
Figure 13. Seat Suspension Lever Release., Vol 5	WP 0663
Figure 14. Suspension Lever., Vol 5	WP 0663
Figure 15. Seat Upper Strap., Vol 5	WP 0663
Figure 16. Rear Seat Hanger Safety Strap., Vol 5	WP 0663
SEATBELT REMOVAL AND INSTALLATION, Vol 5	WP 0664
Figure 1. Seatbelt Retractor., Vol 5	WP 0664
Figure 2. Seatbelt Buckle., Vol 5	WP 0664
Figure 3. Seatbelt Retractor., Vol 5	WP 0664
Figure 4. Seatbelt Buckle., Vol 5	WP 0664
RIGHT FLOOR SEAT BRACKET REMOVAL AND INSTALLATION, Vol 5	WP 0665
Figure 1. Seatbelt Ratchet., Vol 5	WP 0665
Figure 2. Junction Box., Vol 5	WP 0665
Figure 3. HVAC Control Box., Vol 5	WP 0665
Figure 4. Left Front Seatbelt Retractor., Vol 5	WP 0665
Figure 5. Floor Seat Bracket Lower Mounting Bolts., Vol 5	WP 0665
Figure 6. Floor Seat Bracket Upper Mounting Bolts., Vol 5	WP 0665
Figure 7. Floor Seat Bracket Upper Mounting Bolts., Vol 5	WP 0665
Figure 8. Floor Seat Bracket Lower Mounting Bolts., Vol 5	WP 0665
Figure 9. Junction Box Installation., Vol 5	WP 0665
Figure 10. HVAC Control Box, Vol 5	WP 0665
Figure 11. Left Front Seatbelt Retractor., Vol 5	WP 0665
Figure 12. Seatbelt Ratchet Installation., Vol 5	WP 0665
CREW AND FRONT PASSENGER SEAT REMOVAL AND INSTALLATION, Vol 5	WP 0666
Figure 1. Headrest Strap., Vol 5	WP 0666
Figure 2. Headrest Buckle., Vol 5	WP 0666
Figure 3. Rear Seat Hanger Safety Strap., Vol 5	WP 0666
Figure 4. Seat Upper Strap., Vol 5	WP 0666
Figure 5. Suspension Lever., Vol 5	WP 0666
Figure 6. Seat Suspension Lever Release., Vol 5	WP 0666
Figure 7. Seat Suspension Retainer., Vol 5	WP 0666
Figure 8. Floor Anchor., Vol 5	WP 0666
Figure 9. Inboard Eyebolt., Vol 5	WP 0666
Figure 10. Floor Straps., Vol 5	WP 0666
Figure 11. Floor Straps., Vol 5	WP 0666
Figure 12. Inboard Eyebolt., Vol 5	WP 0666
Figure 13. Floor Anchor., Vol 5	WP 0666
Figure 14. Seat Suspension Retainer., Vol 5	WP 0666
Figure 15. Seat Suspension Lever Release., Vol 5	WP 0666
Figure 16. Suspension Lever., Vol 5	WP 0666

TABLE OF CONTENTS – (Continued)

	Page No.
	WP Sequence No.
Figure 17. Seat Upper Strap., Vol 5	WP 0666
Figure 18. Rear Seat Hanger Safety Strap., Vol 5	WP 0666
Figure 19. Headrest Buckle., Vol 5	WP 0666
Figure 20. Headrest Strap., Vol 5	WP 0666
COMMUNICATIONS RACK REMOVAL AND INSTALLATION, Vol 5	WP 0667
Figure 1. Left Front Seat Hanger Safety Strap Tensioner., Vol 5	WP 0667
Figure 2. Left Front Seat Hanger Safety Strap Anchor Pin., Vol 5	WP 0667
Figure 3. Left Front Seat Belt Retractor., Vol 5	WP 0667
Figure 4. Left 12V DC Socket., Vol 5	WP 0667
Figure 5. Communications Rack Top Brackets., Vol 5	WP 0667
Figure 6. Ground Straps. Front Ground Strap Shown. Rear Ground Strap Similar., Vol 5 .	WP 0667
Figure 7. Fire Extinguisher and Bracket., Vol 5	WP 0667
Figure 8. Communications Rack and Left Front Floor Seat Bracket., Vol 5	WP 0667
Figure 9. Communications Rack Brackets., Vol 5	WP 0667
Figure 10. Communications Rack., Vol 5	WP 0667
Figure 11. Communications Rack., Vol 5	WP 0667
Figure 12. Communications Rack Brackets., Vol 5	WP 0667
Figure 13. Communications Rack and Left Front Floor Seat Bracket., Vol 5	WP 0667
Figure 14. Fire Extinguisher and Bracket., Vol 5	WP 0667
Figure 15. Communications Rack Top Brackets., Vol 5	WP 0667
Figure 16. Ground Straps. Front Ground Strap Shown. Rear Ground Strap Similar., Vol 5	WP 0667
Figure 17. Left 12V DC Socket., Vol 5	WP 0667
Figure 18. Left Front Seat Belt Retractor., Vol 5	WP 0667
Figure 19. Seat Hanger Safety Strap Routing., Vol 5	WP 0667
Figure 20. Left Front Seat Hanger Safety Strap Anchor Pin., Vol 5	WP 0667
Figure 21. Left Front Seat Hanger Safety Strap Tensioner., Vol 5	WP 0667
GUNNER PLATFORM/STAND REMOVAL AND INSTALLATION, Vol 5	WP 0668
Figure 1. 12-Volt Junction Box., Vol 5	WP 0668
Figure 2. Gunner Platform Stand Floor Mounting Bolts., Vol 5	WP 0668
Figure 3. Left Side Gunner Platform Stand Mounting Bolts., Vol 5	WP 0668
Figure 4. Right Side Gunner Platform Stand Mounting Bolts., Vol 5	WP 0668
Figure 5. Ammunition Container Assembly., Vol 5	WP 0668
Figure 6. 12-Volt Junction Box., Vol 5	WP 0668
Figure 7. Gunner Platform Stand Floor Mounting Bolts., Vol 5	WP 0668
Figure 8. Gunner Restraint Retaining Ring., Vol 5	WP 0668
Figure 9. Left Side Gunner Platform Stand Mounting Bolts., Vol 5	WP 0668
Figure 10. Right Side Gunner Platform Stand Mounting Bolts., Vol 5	WP 0668
Figure 11. Right Side Gunner Platform Stand Mounting Bolts., Vol 5	WP 0668
Figure 12. Left Side Gunner Platform Stand Mounting Bolts., Vol 5	WP 0668
Figure 13. Gunner Platform Floor Mounting Bolts., Vol 5	WP 0668
Figure 14. 12-Volt Junction Box., Vol 5	WP 0668
Figure 15. Right Side Gunner Platform Stand Mounting Bolts., Vol 5	WP 0668
Figure 16. Left Side Gunner Platform Stand Mounting Bolts., Vol 5	WP 0668
Figure 17. Gunner Platform Stand Floor Mounting Bolts., Vol 5	WP 0668
Figure 18. Gunner Restraint Retaining Ring., Vol 5	WP 0668
Figure 19. 12-Volt Junction Box., Vol 5	WP 0668
Figure 20. Ammunition Container Assembly., Vol 5	WP 0668

TABLE OF CONTENTS – (Continued)

	Page No.
	WP Sequence No.
GUNNER RESTRAINT ASSEMBLY REMOVAL AND INSTALLATION, Vol 5	WP 0669
Figure 1. Gunner Restraint Retaining Ring., Vol 5	WP 0669
Figure 2. Retractor Assembly Rear Mounting Bolt., Vol 5.	WP 0669
Figure 3. Retractor Cap., Vol 5	WP 0669
Figure 4. Retractor Assembly Front Mounting Bolt., Vol 5	WP 0669
Figure 5. Retractor Assembly Mounting Plate., Vol 5	WP 0669
Figure 6. Retractor Assembly Mounting plate., Vol 5.	WP 0669
Figure 7. Retractor Assembly Mounting Bolts., Vol 5.	WP 0669
Figure 8. Retractor Cap., Vol 5	WP 0669
Figure 9. Retractor Assembly Rear Mounting Bolt., Vol 5.	WP 0669
Figure 10. Gunner Restraint Retaining Ring., Vol 5	WP 0669
REAR COMMUNICATION RACK REMOVAL AND INSTALLATION, Vol 5	WP 0670
Figure 1. Rear Communication Rack Upper Tray., Vol 5	WP 0670
Figure 2. Chain Hoist., Vol 5	WP 0670
Figure 3. Rear Communication Rack., Vol 5	WP 0670
Figure 4. Rear Communication Rack. , Vol 5	WP 0670
Figure 5. Chain Hoist., Vol 5	WP 0670
Figure 6. Communications Rack Upper Tray., Vol 5	WP 0670
RIGHT SIDE FORWARD STOWAGE BOX REMOVAL AND INSTALLATION, Vol 5	WP 0671
Figure 1. Right Side Forward Stowage Box Removal., Vol 5	WP 0671
Figure 2. Right Side Forward Stowage Box Installation., Vol 5	WP 0671
AIR CONDITIONING (A/C) CONDENSER PANEL REMOVAL AND INSTALLATION, Vol 5	WP 0672
Figure 1. A/C Condenser Panel Removal., Vol 5	WP 0672
Figure 2. A/C Condenser Panel Installation., Vol 5	WP 0672
RIGHT SIDE REAR STOWAGE BOX REMOVAL AND INSTALLATION, Vol 5.	WP 0673
Figure 1. Sidemarker Harness Retainer., Vol 5	WP 0673
Figure 2. Sidemarker Harness Bolt., Vol 5	WP 0673
Figure 3. Right Rear Stowage Box Removal., Vol 5	WP 0673
Figure 4. Sidemarker Light., Vol 5.	WP 0673
Figure 5. Sidemarker Light Wiring., Vol 5	WP 0673
Figure 6. Right Side Rear Stowage Box Installation., Vol 5	WP 0673
Figure 7. Sidemarker Harness Bolt., Vol 5	WP 0673
Figure 8. Sidemarker Harness Retainer., Vol 5	WP 0673
LEFT SIDE FORWARD STOWAGE BOX REMOVAL AND INSTALLATION, Vol 5	WP 0674
Figure 1. Left Side Forward Stowage Box Removal., Vol 5	WP 0674
Figure 2. Left Side Forward Stowage Box Installation., Vol 5	WP 0674
RIGHT REAR STOWAGE BOX LATCH REMOVAL AND INSTALLATION, Vol 5	WP 0675
Figure 1. Stowage Box Latch Removal., Vol 5	WP 0675
Figure 2. Stowage Box Latch Installation., Vol 5	WP 0675
LEFT REAR STOWAGE BOX REMOVAL AND INSTALLATION, Vol 5	WP 0676
Figure 1. Left Rear Stowage Box Removal., Vol 5.	WP 0676
Figure 2. Left Rear Stowage Box Removal., Vol 5.	WP 0676
Figure 3. Left Rear Stowage Box Inside Bolts., Vol 5	WP 0676
Figure 4. Sidemarker Wiring., Vol 5	WP 0676
Figure 5. Sidemarker Wiring., Vol 5	WP 0676
Figure 6. Left Rear Stowage Box Inside Bolts., Vol 5	WP 0676
Figure 7. Left Rear Stowage Box Installation., Vol 5	WP 0676
Figure 8. Sidemarker Harness Retainer., Vol 5	WP 0676

TABLE OF CONTENTS – (Continued)

	Page No.
	<u>WP Sequence No.</u>
WINCH CABLE REMOVAL AND INSTALLATION, Vol 5	WP 0677
Figure 1. Hook and Coupler., Vol 5	WP 0677
Figure 2. Winch Cable and Drum., Vol 5	WP 0677
Figure 3. Winch Cable and Drum., Vol 5	WP 0677
Figure 4. Hook and Coupler., Vol 5	WP 0677
WINCH ASSEMBLY REMOVAL AND INSTALLATION, Vol 5	WP 0678
Figure 1. Junction Block., Vol 5	WP 0678
Figure 2. Winch Harness Support., Vol 5.	WP 0678
Figure 3. Hook and Coupler., Vol 5	WP 0678
Figure 4. Winch Carrier Removal., Vol 5	WP 0678
Figure 5. Front Crossmember Bolts., Vol 5	WP 0678
Figure 6. Winch Assembly Removal., Vol 5.	WP 0678
Figure 7. Winch Assembly Installation., Vol 5.	WP 0678
Figure 8. Front Crossmember Bolt Installation., Vol 5	WP 0678
Figure 9. Winch Carrier Installation., Vol 5	WP 0678
Figure 10. Hook and Coupler., Vol 5.	WP 0678
Figure 11. Winch Harness Support., Vol 5	WP 0678
Figure 12. Junction Block., Vol 5	WP 0678
LITTER ARM STORAGE BRACKET REMOVAL AND INSTALLATION, Vol 5	WP 0679
Figure 1. Litter Arms., Vol 5	WP 0679
Figure 2. Litter Arm Storage Bracket., Vol 5	WP 0679
Figure 3. Litter Arm Storage Bracket., Vol 5	WP 0679
Figure 4. Litter Arms., Vol 5	WP 0679
FRONT LITTER ARM MOUNT PLATE AND ARM SUPPORT REMOVAL AND INSTALLATION, Vol 5	WP 0680
Figure 1. Front Litter Arm Mount Plate., Vol 5.	WP 0680
Figure 2. Arm Support., Vol 5.	WP 0680
Figure 3. Die Mark., Vol 5	WP 0680
Figure 4. Arm Support., Vol 5.	WP 0680
Figure 5. Front Litter Arm Mount Plate., Vol 5.	WP 0680
REAR LITTER ARM MOUNT PLATE AND ARM SUPPORT REMOVAL AND INSTALLATION, Vol 5	WP 0681
Figure 1. Rear Litter Arm Mount Plate., Vol 5	WP 0681
Figure 2. Arm Support., Vol 5.	WP 0681
Figure 3. Die Mark., Vol 5	WP 0681
Figure 4. Arm Support., Vol 5.	WP 0681
Figure 5. Rear Litter Arm Mount Plate., Vol 5.	WP 0681
DOOR MOUNTED MIRROR REMOVAL AND INSTALLATION, Vol 5	WP 0682
Figure 1. Door Mounted Mirror., Vol 5	WP 0682
Figure 2. Door Mounted Mirror., Vol 5	WP 0682

TABLE OF CONTENTS – (Continued)

	Page No.
	<u>WP Sequence No.</u>
WIPER COWL PANEL REMOVAL AND INSTALLATION, Vol 5	WP 0683
Figure 1. Windshield Wiper Motor Cover., Vol 5	WP 0683
Figure 2. Windshield Wiper Idler Shaft Driver., Vol 5	WP 0683
Figure 3. Windshield Wiper Idler Shaft Nut., Vol 5	WP 0683
Figure 4. Cowl Panel., Vol 5	WP 0683
Figure 5. Windshield Washer Pump Hose., Vol 5	WP 0683
Figure 6. Underside of Cowl Panel., Vol 5	WP 0683
Figure 7. Windshield Washer Wet Arm Adapter Nut., Vol 5	WP 0683
Figure 8. Windshield Washer Wet Arm Adapter and Sealing Washer., Vol 5	WP 0683
Figure 9. Windshield Washer Wet Arm Adapter and Sealing Washer., Vol 5	WP 0683
Figure 10. Windshield Washer Wet Arm Adapter Nut., Vol 5	WP 0683
Figure 11. Windshield Washer Wet Arm Adapter Alignment., Vol 5	WP 0683
Figure 12. Underside of Cowl Panel., Vol 5	WP 0683
Figure 13. Windshield Washer Pump Hose., Vol 5	WP 0683
Figure 14. Windshield Wiper Linkage and Idler Shaft Alignment., Vol 5	WP 0683
Figure 15. Windshield Wiper Idler Shaft., Vol 5	WP 0683
Figure 16. Windshield Wiper Idler Shaft Nut., Vol 5	WP 0683
Figure 17. Windshield Wiper Washer Hose., Vol 5	WP 0683
Figure 18. Windshield Wiper Motor Wiring Harness., Vol 5	WP 0683
Figure 19. Cowl Panel., Vol 5	WP 0683
Figure 20. Windshield Wiper Idler Shaft Driver., Vol 5	WP 0683
Figure 21. Windshield Wiper Motor Cover., Vol 5	WP 0683
WINDSHIELD WIPER MOTOR, TRANSMISSION, BRACKET, AND LINKAGE ASSEMBLY REMOVAL AND INSTALLATION, Vol 5	WP 0684
Figure 1. Windshield Wiper Motor Harness Cable Lock Strap., Vol 5	WP 0684
Figure 2. Windshield Wiper Motor Harness., Vol 5	WP 0684
Figure 3. Windshield Wiper Motor Assembly Bolts., Vol 5	WP 0684
Figure 4. Windshield Wiper Motor Assembly., Vol 5	WP 0684
Figure 5. Windshield Wiper Motor Assembly., Vol 5	WP 0684
Figure 6. Windshield Wiper Motor Assembly Bolts., Vol 5	WP 0684
Figure 7. Windshield Wiper Motor Harness., Vol 5	WP 0684
Figure 8. Windshield Wiper Motor Harness Cable Lock Strap., Vol 5	WP 0684
WINDSHIELD WIPER ARM AND BLADE ASSEMBLY REMOVAL AND INSTALLATION, Vol 5	WP 0685
Figure 1. Windshield Wiper Arm Nut and Washer Hose., Vol 5	WP 0685
Figure 2. Windshield Wiper Arm Lockwasher., Vol 5	WP 0685
Figure 3. Windshield Wiper Arm and Blade Assembly., Vol 5	WP 0685
Figure 4. Knurled Driver on Idler Shaft., Vol 5	WP 0685
Figure 5. Windshield Wiper Arm and Blade Assembly Installation and Alignment., Vol 5	WP 0685
Figure 6. Windshield Wiper Arm Lockwasher., Vol 5	WP 0685
Figure 7. Windshield Wiper Arm Nut and Washer Hose., Vol 5	WP 0685
WINDSHIELD WASHER RESERVOIR AND PUMP MOTOR ASSEMBLY REMOVAL AND INSTALLATION, Vol 5	WP 0686
Figure 1. Windshield Washer Fluid Reservoir., Vol 5	WP 0686
Figure 2. Windshield Washer Pump Harness Connector., Vol 5	WP 0686
Figure 3. Windshield Washer Pump Hose., Vol 5	WP 0686
Figure 4. Windshield Washer Pump Hose., Vol 5	WP 0686
Figure 5. Windshield Washer Reservoir and Pump Motor., Vol 5	WP 0686
Figure 6. Windshield Washer Pump Harness Connector., Vol 5	WP 0686

TABLE OF CONTENTS – (Continued)

	Page No.
	<u>WP Sequence No.</u>
WINDSHIELD WASHER HOSE ASSEMBLY REMOVAL AND INSTALLATION, Vol 5	WP 0687
Figure 1. Windshield Washer Pump Hose Routing., Vol 5	WP 0687
Figure 2. Windshield Washer Pump Hose Routing., Vol 5	WP 0687
Figure 3. Windshield Washer Pump Hose Routing., Vol 5	WP 0687
Figure 4. Windshield Washer Pump Hose Routing., Vol 5	WP 0687
Figure 5. Windshield Washer Pump Hose to Washer Pump., Vol 5	WP 0687
Figure 6. Windshield Washer Pump Hose to Washer Pump., Vol 5	WP 0687
Figure 7. Windshield Washer Pump Hose Routing., Vol 5	WP 0687
Figure 8. Windshield Washer Pump Hose Routing., Vol 5	WP 0687
Figure 9. Windshield Washer Pump Hose Routing., Vol 5	WP 0687
Figure 10. Windshield Washer Pump Hose Routing., Vol 5	WP 0687
WINDSHIELD WASHER RESERVOIR BRACKET REMOVAL AND INSTALLATION, Vol 5	WP 0688
Figure 1. Windshield Washer Reservoir Bracket., Vol 5	WP 0688
Figure 2. Windshield Washer Reservoir Bracket., Vol 5	WP 0688
WINDSHIELD WIPER MOTOR HARNESS REMOVAL AND INSTALLATION, Vol 5	WP 0689
Figure 1. Power Distribution Center (PDC) Armor Plate., Vol 5	WP 0689
Figure 2. Windshield Wiper Motor Harness Connector., Vol 5	WP 0689
Figure 3. Windshield Wiper Motor Harness Routing On Bulkhead., Vol 5	WP 0689
Figure 4. Windshield Wiper Motor Harness Routing On Cowl., Vol 5	WP 0689
Figure 5. Windshield Wiper Motor Harness Cable Lock Strap., Vol 5	WP 0689
Figure 6. Windshield Wiper Motor Harness Connection., Vol 5	WP 0689
Figure 7. Windshield Wiper Motor Harness Connection., Vol 5	WP 0689
Figure 8. Windshield Wiper Motor Harness Cable Lock Strap., Vol 5	WP 0689
Figure 9. Windshield Wiper Motor Harness Routing On Cowl., Vol 5	WP 0689
Figure 10. Windshield Wiper Motor Harness Routing On Bulkhead., Vol 5	WP 0689
Figure 11. Windshield Wiper Motor Harness Connector., Vol 5	WP 0689
Figure 12. PDC Armor Plate., Vol 5	WP 0689
REAR DOOR/RAMP HYDRAULIC PUMP COVER REMOVAL AND INSTALLATION (PUSH-TYPE OPERATION), Vol 5	WP 0690
Figure 1. Rear Door/Ramp Hydraulic Pump Cover., Vol 5	WP 0690
Figure 2. Rear Door/Ramp Hydraulic Pump Cover., Vol 5	WP 0690
REAR DOOR/RAMP HYDRAULIC PUMP COVER REMOVAL AND INSTALLATION (PULL-TYPE OPERATION), Vol 5	WP 0691
Figure 1. Removing Pump Handle., Vol 5	WP 0691
Figure 2. Rear Door/Ramp Hydraulic Pump Cover Removal., Vol 5	WP 0691
Figure 3. Rear Door/Ramp Hydraulic Pump Cover Installation., Vol 5	WP 0691
Figure 4. Installing Pump Handle., Vol 5	WP 0691
REAR DOOR/RAMP HYDRAULIC PUMP REMOVAL AND INSTALLATION (PUSH-TYPE OPERATION), Vol 5	WP 0692
Figure 1. Hydraulic Pump and Valve Assembly Electrical Connections., Vol 5	WP 0692
Figure 2. Hydraulic Valve Assembly Hose Connections., Vol 5	WP 0692
Figure 3. Rear Door/Ramp Hydraulic Pump Mounting Bolts., Vol 5	WP 0692
Figure 4. Rear Door/Ramp Hydraulic Pump Mounting Bolts., Vol 5	WP 0692
Figure 5. Hydraulic Valve Assembly Hose Connections., Vol 5	WP 0692
Figure 6. Hydraulic Pump and Valve Assembly Electrical Connections., Vol 5	WP 0692
REAR DOOR/RAMP HYDRAULIC PUMP REMOVAL AND INSTALLATION (PULL-TYPE OPERATION), Vol 5	WP 0693
Figure 1. Disconnecting Hydraulic Pump Solenoid., Vol 5	WP 0693
Figure 2. Connecting Hydraulic Pump Solenoid., Vol 5	WP 0693

TABLE OF CONTENTS – (Continued)

	Page No.
	<u>WP Sequence No.</u>
REAR DOOR/RAMP HYDRAULIC HAND PUMP REMOVAL AND INSTALLATION (PUSH-TYPE OPERATION), Vol 5	WP 0694
Figure 1. Rear Door/Ramp Hand Pump., Vol 5	WP 0694
Figure 2. Rear Door/Ramp Hand Pump., Vol 5	WP 0694
REAR DOOR/RAMP HYDRAULIC POWER UNIT MANIFOLD AND MODULE REMOVAL AND INSTALLATION (PULL-TYPE OPERATION), Vol 5	WP 0695
Figure 1. Hydraulic Power Unit Manifold and Module Removal., Vol 5	WP 0695
Figure 2. Hydraulic Power Unit Manifold and Module Installation., Vol 5	WP 0695
REAR DOOR/RAMP HYDRAULIC CYLINDER REMOVAL AND INSTALLATION (PUSH-TYPE OPERATION), Vol 5	WP 0696
Figure 1. Rear Door/Ramp Lowered and Supported with Jackstand., Vol 5	WP 0696
Figure 2. Right Side Upper Shroud Cover., Vol 5	WP 0696
Figure 3. Hydraulic Transfer Block Hose Connection., Vol 5	WP 0696
Figure 4. Hydraulic Cylinder Locking Safety Pin., Vol 5	WP 0696
Figure 5. Hydraulic Cylinder Upper Lockpin Shaft and Cotter Pin., Vol 5	WP 0696
Figure 6. Hydraulic Cylinder Upper Lockpin Shaft and Cotter Pin., Vol 5	WP 0696
Figure 7. Hydraulic Cylinder Locking Safety Pin., Vol 5	WP 0696
Figure 8. Hydraulic Transfer Block Hose Connection., Vol 5	WP 0696
Figure 9. Hydraulic Reservoir Filled with Hydraulic Fluid., Vol 5	WP 0696
Figure 10. Restoration of Hydraulic Pressure in Hydraulic Pump Assembly., Vol 5	WP 0696
Figure 11. Jackstand Removed from Rear Door/Ramp., Vol 5	WP 0696
Figure 12. Right Side Upper Shroud Cover., Vol 5	WP 0696
REAR DOOR/RAMP HYDRAULIC CYLINDER REMOVAL AND INSTALLATION (PULL-TYPE OPERATION), Vol 5	WP 0697
Figure 1. Manual Override Directional Valve., Vol 5	WP 0697
Figure 2. Rear Door/Ramp Lowered and Supported with Jackstand., Vol 5	WP 0697
Figure 3. Right Side Upper Shroud Cover Removal., Vol 5	WP 0697
Figure 4. Hydraulic Hose Lines Removal and Hydraulic Fluid Drained., Vol 5	WP 0697
Figure 5. Locking Safety Pin Removed from Hydraulic Cylinder., Vol 5	WP 0697
Figure 6. Cotter Pin and Hydraulic Cylinder Removal., Vol 5	WP 0697
Figure 7. Rear Door/Ramp Hydraulic Cylinder Installed in Upper Door Lock Bracket., Vol 5	WP 0697
Figure 8. Hydraulic Cylinder Installed on Rear/Door Ramp., Vol 5	WP 0697
Figure 9. Hydraulic Hose Lines Connected to Transfer Block., Vol 5	WP 0697
Figure 10. Jackstand Removed from Rear Door/Ramp., Vol 5	WP 0697
Figure 11. Right Side Upper Shroud Cover Installed., Vol 5	WP 0697
REAR DOOR/RAMP GAS SPRING REMOVAL AND INSTALLATION, Vol 5	WP 0698
Figure 1. Right Side Upper Shroud Cover., Vol 5	WP 0698
Figure 2. Upper Door/Ramp Lock Bracket Front Bolts., Vol 5	WP 0698
Figure 3. Lowering Upper Lock Bracket and Removing Gas Spring., Vol 5	WP 0698
Figure 4. Rear Door/Ramp Lower Gas Spring Bracket., Vol 5	WP 0698
Figure 5. Rear Door/Ramp Lower Gas Spring Bracket., Vol 5	WP 0698
Figure 6. Installing Gas Spring and Securing Upper Lock Bracket., Vol 5	WP 0698
Figure 7. Upper Door Lock Bracket Bolts., Vol 5	WP 0698
Figure 8. Right Side Upper Shroud Cover., Vol 5	WP 0698
REAR DOOR/RAMP HYDRAULIC RESERVOIR FLUID FILL PROCEDURE (PULL-TYPE OPERATION), Vol 5	WP 0699
Figure 1. Hydraulic Reservoir Cap Removal., Vol 5	WP 0699
Figure 2. Hydraulic Reservoir Filling., Vol 5	WP 0699
Figure 3. Hydraulic Reservoir Cap Installation., Vol 5	WP 0699

TABLE OF CONTENTS – (Continued)

	Page No.
	<u>WP Sequence No.</u>
REAR DOOR/RAMP HYDRAULIC HOSES REMOVAL AND INSTALLATION (PUSH-TYPE OPERATION), Vol 5	WP 0700
Figure 1. Hydraulic Fluid Drained from Rear Door/Ramp Hydraulic Reservoir., Vol 5	WP 0700
Figure 2. Three Hydraulic Hoses Removed., Vol 5	WP 0700
Figure 3. Three Hydraulic Hoses Installed., Vol 5	WP 0700
Figure 4. Hydraulic Reservoir Refilled with Hydraulic Fluid., Vol 5	WP 0700
Figure 5. Restoration of Hydraulic Pressure in Hydraulic Pump Assembly., Vol 5	WP 0700
REAR DOOR/RAMP HYDRAULIC HOSES REMOVAL AND INSTALLATION (PULL-TYPE OPERATION), Vol 5	WP 0701
Figure 1. Manual Override Directional Valve., Vol 5	WP 0701
Figure 2. Rear Door/Ramp Lowered and Supported with Jackstand., Vol 5	WP 0701
Figure 3. Hydraulic Power Module-to-Hydraulic Cylinder Hose Removal., Vol 5	WP 0701
Figure 4. Hydraulic Power Module-to-Hydraulic Cylinder Hose Removal., Vol 5	WP 0701
Figure 5. Hydraulic Power Module-to-Hydraulic Cylinder Hose Removal., Vol 5	WP 0701
Figure 6. Hydraulic Power Module-to-Hydraulic Cylinder Hose Removal., Vol 5	WP 0701
Figure 7. Hydraulic Cylinder Short Vertical Hose Removal., Vol 5	WP 0701
Figure 8. Hydraulic Cylinder Long Vertical Hose Removal., Vol 5	WP 0701
Figure 9. Hydraulic Cylinder Long Vertical Hose Installation., Vol 5	WP 0701
Figure 10. Hydraulic Cylinder Short Vertical Hose Installation., Vol 5	WP 0701
Figure 11. Hydraulic Power Module-to-Hydraulic Cylinder Hose Installation., Vol 5	WP 0701
Figure 12. Hydraulic Power Module-to-Hydraulic Cylinder Hose Installation., Vol 5	WP 0701
Figure 13. Hydraulic Power Module-to-Hydraulic Cylinder Hose Installation., Vol 5	WP 0701
Figure 14. Hydraulic Power Module-to-Hydraulic Cylinder Hose Installation., Vol 5	WP 0701
Figure 15. Jackstand Removed from Rear Door/Ramp., Vol 5	WP 0701
OUTSIDE GUNNER PROTECTION RISER REMOVAL AND INSTALLATION, Vol 5	WP 0702
Figure 1. Chain Hoists and Lifting Slings., Vol 5	WP 0702
Figure 2. Outside Gunner Protection Riser Removal., Vol 5	WP 0702
Figure 3. Chain Hoists and Lifting Slings., Vol 5	WP 0702
Figure 4. Outside Gunner Riser Bolts Installation., Vol 5	WP 0702
OUTSIDE GUNNER PROTECTION ARMOR REMOVAL AND INSTALLATION, Vol 5	WP 0703
Figure 1. Gunner Protection Armor., Vol 5	WP 0703
Figure 2. Gunner Protection Armor., Vol 5	WP 0703
GUN TURRET PLATFORM REMOVAL AND INSTALLATION, Vol 5	WP 0704
Figure 1. Chain Hoists and Lifting Slings., Vol 5	WP 0704
Figure 2. Gun Turret Removal., Vol 5	WP 0704
Figure 3. Chain Hoists and Lifting Slings., Vol 5	WP 0704
Figure 4. Gun Turret Platform Installation., Vol 5	WP 0704
TURRET MOUNTING PLATE REMOVAL AND INSTALLATION, Vol 5	WP 0705
Figure 1. Turret Mounting Plate Bolts Removal., Vol 5	WP 0705
Figure 2. Turret Mounting Plate Removal., Vol 5	WP 0705
Figure 3. Turret Mounting Plate Installation., Vol 5	WP 0705
Figure 4. Turret Mounting Plate Bolts Installation., Vol 5	WP 0705
RIFLE RACK REMOVAL AND INSTALLATION, Vol 5	WP 0706
Figure 1. Rifle Rack., Vol 5	WP 0706
Figure 2. Rifle Rack., Vol 5	WP 0706

TABLE OF CONTENTS – (Continued)

	<u>Page No.</u>
	<u>WP Sequence No.</u>
HEATING VENTILATING AND AIR CONDITIONING (HVAC) SERVICE/RECHARGE	
PROCEDURE, Vol 5	WP 0707
Figure 1. HVAC Service Ports., Vol 5	WP 0707
Figure 2. Recovery/Recharging Station., Vol 5	WP 0707
Figure 3. HVAC Service Ports., Vol 5	WP 0707
Figure 4. Recovery/Recharging Station., Vol 5	WP 0707
Figure 5. Recovery/Recharging Station., Vol 5	WP 0707
Figure 6. HVAC Service Ports., Vol 5	WP 0707
Table 1. R134a Refrigerant Temperature vs Pressure., Vol 5	WP 0707
HEATING VENTILATING AND AIR CONDITIONING (HVAC) COMPRESSOR REMOVAL AND	
INSTALLATION, Vol 5	WP 0708
Figure 1. HVAC Hoses At Compressor., Vol 5	WP 0708
Figure 2. HVAC Compressor., Vol 5	WP 0708
Figure 3. HVAC Compressor., Vol 5	WP 0708
Figure 4. HVAC Hoses At Compressor., Vol 5	WP 0708
HEATING VENTILATING AND AIR CONDITIONING (HVAC) EVAPORATOR INLET HOSE REMOVAL AND	
INSTALLATION, Vol 5	WP 0709
Figure 1. Right Main Duct Cover., Vol 5	WP 0709
Figure 2. Rear Electricity Duct., Vol 5	WP 0709
Figure 3. Evaporator Inlet Hose at Penetration Dust Plate., Vol 5	WP 0709
Figure 4. Evaporator Inlet Hose at Evaporator., Vol 5	WP 0709
Figure 5. HVAC Hose End with O-Ring Installed., Vol 5	WP 0709
Figure 6. HVAC Hose End with O-Ring., Vol 5	WP 0709
Figure 7. Evaporator Inlet Hose at Penetration Dust Plate., Vol 5	WP 0709
Figure 8. Evaporator Inlet Hose at Evaporator., Vol 5	WP 0709
Figure 9. Rear Electricity Duct., Vol 5	WP 0709
Figure 10. Right Main Duct Cover., Vol 5.	WP 0709
HEATING VENTILATING AND AIR CONDITIONING (HVAC) EVAPORATOR OUTLET HOSE REMOVAL	
AND INSTALLATION, Vol 5.	WP 0710
Figure 1. Right Main Duct Cover., Vol 5	WP 0710
Figure 2. Rear Electricity Duct., Vol 5	WP 0710
Figure 3. Penetration Dust Plate., Vol 5	WP 0710
Figure 4. Penetration Dust Plate., Vol 5	WP 0710
Figure 5. Penetration Dust Plate., Vol 5	WP 0710
Figure 6. Evaporator Inlet Hose at Evaporator., Vol 5	WP 0710
Figure 7. Evaporator Outlet Hose at Evaporator., Vol 5	WP 0710
Figure 8. HVAC Hose End with O-Ring Installed., Vol 5	WP 0710
Figure 9. HVAC Hose End with O-Ring., Vol 5	WP 0710
Figure 10. Evaporator Outlet Hose at Penetration Dust Plate., Vol 5	WP 0710
Figure 11. Evaporator Outlet Hose at Evaporator., Vol 5	WP 0710
Figure 12. Evaporator Inlet Hose at Evaporator., Vol 5	WP 0710
Figure 13. Penetration Dust Plate., Vol 5.	WP 0710
Figure 14. Penetration Dust Plate., Vol 5.	WP 0710
Figure 15. Rear HVAC Channel Cover., Vol 5.	WP 0710
Figure 16. Right HVAC Channel Cover., Vol 5	WP 0710

TABLE OF CONTENTS – (Continued)

	Page No.
	<u>WP Sequence No.</u>
HEATING VENTILATING AND AIR CONDITIONING (HVAC) FILTER OUTLET HOSE REMOVAL AND INSTALLATION, Vol 5	WP 0711
Figure 1. HVAC Filter Outlet., Vol 5	WP 0711
Figure 2. HVAC Filter Outlet Hose at Penetration Dust Plate., Vol 5	WP 0711
Figure 3. HVAC Filter Outlet Hose O-Ring., Vol 5	WP 0711
Figure 4. HVAC Filter Outlet Hose O-Ring., Vol 5	WP 0711
Figure 5. HVAC Filter Outlet., Vol 5	WP 0711
Figure 6. HVAC Filter Outlet Hose at Penetration Dust Plate., Vol 5	WP 0711
HEATING VENTILATING AND AIR CONDITIONING (HVAC) COMPRESSOR SUCTION HOSE REMOVAL AND INSTALLATION, Vol 5.	WP 0712
Figure 1. HVAC Compressor Suction Hose at Compressor Inlet., Vol 5.	WP 0712
Figure 2. HVAC Compressor Suction Hose at Penetration Dust Plate., Vol 5	WP 0712
Figure 3. O-Rings, Vol 5	WP 0712
Figure 4. O-Ring Installation., Vol 5	WP 0712
Figure 5. Compressor Inlet., Vol 5.	WP 0712
Figure 6. HVAC Compressor Suction Hose at Penetration Dust Plate., Vol 5	WP 0712
HEATING VENTILATING AND AIR CONDITIONING (HVAC) LEFT-SIDE CONDENSER INLET HOSE REMOVAL AND INSTALLATION, Vol 5	WP 0713
Figure 1. Left HVAC Condenser Hose at Tee., Vol 5.	WP 0713
Figure 2. Condenser Hose., Vol 5.	WP 0713
Figure 3. Left Front Opening to Cab Double-Floor., Vol 5.	WP 0713
Figure 4. Left Condenser Hose Fitting., Vol 5.	WP 0713
Figure 5. Left Rear Opening to Cab Double-Floor., Vol 5.	WP 0713
Figure 6. Condenser Hose., Vol 5.	WP 0713
Figure 7. Condenser Hose., Vol 5.	WP 0713
Figure 8. Condenser Hose., Vol 5.	WP 0713
Figure 9. Condenser Hose., Vol 5.	WP 0713
Figure 10. Condenser Hoses., Vol 5.	WP 0713
Figure 11. Condenser Hose., Vol 5	WP 0713
Figure 12. Condenser Hose., Vol 5	WP 0713
Figure 13. Left HVAC Condenser Hose at Tee., Vol 5	WP 0713
HEATING VENTILATING AND AIR CONDITIONING (HVAC) RIGHT-SIDE CONDENSER INLET HOSE REMOVAL AND INSTALLATION, Vol 5	WP 0714
Figure 1. Condenser Inlet Hose Fittings., Vol 5	WP 0714
Figure 2. Condenser Inlet Hose at Tee., Vol 5	WP 0714
Figure 3. Condenser Inlet Hose., Vol 5	WP 0714
Figure 4. Cab Right-Side Double-Floor Front Opening., Vol 5.	WP 0714
Figure 5. Condenser Inlet Hose., Vol 5	WP 0714
Figure 6. Cab Right-Side Double-Floor Rear Opening., Vol 5	WP 0714
Figure 7. Condenser Inlet Hose., Vol 5	WP 0714
Figure 8. O-Rings., Vol 5	WP 0714
Figure 9. Condenser Inlet Hose Fittings., Vol 5	WP 0714
Figure 10. Condenser Inlet Hose at Tee., Vol 5	WP 0714

TABLE OF CONTENTS – (Continued)

	<u>Page No.</u>
	<u>WP Sequence No.</u>
HEATING VENTILATING AND AIR CONDITIONING (HVAC) LEFT-SIDE CONDENSER OUTLET HOSE	
REMOVAL AND INSTALLATION, Vol 5	WP 0715
Figure 1. Left Condenser Outlet Hose Fitting at HVAC Filter., Vol 5	WP 0715
Figure 2. Condenser Outlet Hose., Vol 5	WP 0715
Figure 3. Left Front Opening to Cab Double-Floor., Vol 5.	WP 0715
Figure 4. Left Condenser Outlet Hose Fitting., Vol 5	WP 0715
Figure 5. Left Rear Opening to Cab Double-Floor., Vol 5	WP 0715
Figure 6. Condenser Outlet Hose., Vol 5	WP 0715
Figure 7. Condenser Hose., Vol 5	WP 0715
Figure 8. Condenser Hose., Vol 5	WP 0715
Figure 9. Condenser Hose., Vol 5	WP 0715
Figure 10. Condenser Hose., Vol 5	WP 0715
Figure 11. Condenser Hose., Vol 5	WP 0715
Figure 12. Condenser Hose., Vol 5	WP 0715
Figure 13. Left HVAC Condenser Hose at Tee., Vol 5	WP 0715
HEATING VENTILATING AND AIR CONDITIONING (HVAC) RIGHT-SIDE CONDENSER OUTLET HOSE	
REMOVAL AND INSTALLATION, Vol 5	WP 0716
Figure 1. Right HVAC Condenser Hose Fittings., Vol 5.	WP 0716
Figure 2. Right HVAC Condenser Hose at Filter., Vol 5.	WP 0716
Figure 3. Right Front Opening to Cab Double-Floor., Vol 5	WP 0716
Figure 4. Right Rear Opening to Cab Double-Floor., Vol 5	WP 0716
Figure 5. Right Rear Opening to Cab Double-Floor., Vol 5	WP 0716
Figure 6. Left Front Opening to Cab Double-Floor., Vol 5.	WP 0716
Figure 7. Right HVAC Condenser Hose Fittings., Vol 5.	WP 0716
Figure 8. Right HVAC Condenser Hose at Tee., Vol 5	WP 0716
HEATING VENTILATING AND AIR CONDITIONING (HVAC) COMPRESSOR DISCHARGE HOSE	
REMOVAL AND INSTALLATION, Vol 5	WP 0717
Figure 1. 3-Way Valve., Vol 5.	WP 0717
Figure 2. Compressor Discharge Hose Heat Shrink Tubing., Vol 5.	WP 0717
Figure 3. HVAC Compressor Discharge Hose at Compressor., Vol 5.	WP 0717
Figure 4. HVAC Compressor Discharge Hose at T-fitting., Vol 5.	WP 0717
Figure 5. HVAC Compressor Discharge Hose at Compressor., Vol 5.	WP 0717
Figure 6. HVAC Compressor Discharge Hose at T-fitting., Vol 5.	WP 0717
Figure 7. Compressor Discharge Outlet Heat Shrink Tubing, Vol 5	WP 0717
Figure 8. HVAC Compressor Discharge Hose at Tee., Vol 5	WP 0717
Figure 9. 3-Way Valve., Vol 5.	WP 0717
HEATING VENTILATING AND AIR CONDITIONING (HVAC) SERVICE PORT/SCHRADER VALVE	
REMOVAL AND INSTALLATION, Vol 5	WP 0718
Figure 1. HVAC Service Port., Vol 5	WP 0718
Figure 2. HVAC Service Port., Vol 5	WP 0718
HEATING VENTILATING AND AIR CONDITIONING (HVAC) WATER DRAINAGE HOSE REMOVAL AND	
INSTALLATION, Vol 5	WP 0719
Figure 1. HVAC Water Drainage Hose Upper End., Vol 5.	WP 0719
Figure 2. HVAC Water Drainage Hose Lower End., Vol 5.	WP 0719
Figure 3. HVAC Water Drainage Hose Upper End., Vol 5.	WP 0719
Figure 4. HVAC Water Drainage Hose Lower End., Vol 5.	WP 0719
HEATING VENTILATING AND AIR CONDITIONING (HVAC) FRESH AIR INLET TUBE REMOVAL AND	
INSTALLATION, Vol 5	WP 0720
Figure 1. Fresh Air Inlet Tube., Vol 5	WP 0720
Figure 2. Fresh Air Inlet Tube., Vol 5	WP 0720

TABLE OF CONTENTS – (Continued)

	Page No.
	<u>WP Sequence No.</u>
NUCLEAR, BIOLOGICAL, AND CHEMICAL (NBC) DUST TUBE REMOVAL AND INSTALLATION, Vol 5	WP 0721
Figure 1. External Dust Tube at Forward Side of Heating Ventilating and Air Conditioning (HVAC)/Life Support System (LSS) Box., Vol 5	WP 0721
Figure 2. Dust Tube at Forward Side of HVAC/LSS Box., Vol 5	WP 0721
Figure 3. External Dust Tube at Floor Under Right Front Seat., Vol 5	WP 0721
Figure 4. Dust Tube at Floor Under Right Front Seat., Vol 5	WP 0721
Figure 5. Dust Tube at Floor Under Right Front Seat., Vol 5	WP 0721
Figure 6. External Dust Tube at Floor Under Right Front Seat., Vol 5	WP 0721
Figure 7. Dust Tube at Forward Side of HVAC/LSS Box., Vol 5	WP 0721
Figure 8. External Dust Tube at Forward Side of HVAC/LSS Box., Vol 5	WP 0721
HEATING VENTILATING AND AIR CONDITIONING (HVAC) REFRIGERANT FILTER REMOVAL AND INSTALLATION, Vol 5	WP 0722
Figure 1. HVAC Filter., Vol 5	WP 0722
Figure 2. O-Ring Removal., Vol 5	WP 0722
Figure 3. O-Ring Installation., Vol 5	WP 0722
Figure 4. HVAC Filter., Vol 5	WP 0722
HEATING VENTILATING AND AIR CONDITIONING (HVAC) CONDENSER REMOVAL AND INSTALLATION, Vol 5	WP 0723
Figure 1. HVAC Condenser Lines., Vol 5	WP 0723
Figure 2. HVAC Condenser Unit., Vol 5	WP 0723
Figure 3. HVAC Condenser Unit., Vol 5	WP 0723
Figure 4. HVAC Condenser Fan Assembly., Vol 5	WP 0723
Figure 5. HVAC Condenser Fan Assembly., Vol 5	WP 0723
Figure 6. HVAC Condenser Unit., Vol 5	WP 0723
Figure 7. HVAC Condenser Unit., Vol 5	WP 0723
Figure 8. HVAC Condenser Lines., Vol 5	WP 0723
AIR CONDITIONER CONDENSER FAN ASSEMBLY REMOVAL AND INSTALLATION, Vol 5	WP 0724
Figure 1. Condenser Fan Assembly Harness Connection., Vol 5	WP 0724
Figure 2. Condenser Fan Assembly., Vol 5	WP 0724
Figure 3. Condenser Fan Assembly., Vol 5	WP 0724
Figure 4. Condenser Fan Assembly Harness Connection., Vol 5	WP 0724
ENGINE WATER OUTLET PIPE AND ELBOW REMOVAL AND INSTALLATION, Vol 5	WP 0725
Figure 1. Engine Water Outlet Pipe Assembly., Vol 5	WP 0725
Figure 2. Engine Water Outlet Pipe Assembly., Vol 5	WP 0725
HEATING VENTILATING AND AIR CONDITIONING (HVAC) 3-WAY VALVE COOLANT OUTLET HOSE REMOVAL AND INSTALLATION, Vol 5	WP 0726
Figure 1. Heater Coolant Engine Outlet Valve., Vol 5	WP 0726
Figure 2. Heater Coolant Engine Inlet Valve., Vol 5	WP 0726
Figure 3. Outlet Hose at 3-Way Valve., Vol 5	WP 0726
Figure 4. Outlet Hose at Dust Plate., Vol 5	WP 0726
Figure 5. Outlet Hose at Dust Plate., Vol 5	WP 0726
Figure 6. Outlet Hose at 3-Way Valve., Vol 5	WP 0726
Figure 7. Heater Coolant Engine Outlet Valve., Vol 5	WP 0726
Figure 8. Heater Coolant Engine Inlet Valve., Vol 5	WP 0726

TABLE OF CONTENTS – (Continued)

	<u>Page No.</u>
	<u>WP Sequence No.</u>
HEATING VENTILATING AND AIR CONDITIONING (HVAC) 3-WAY VALVE REMOVAL AND INSTALLATION, Vol 5	WP 0727
Figure 1. Heater Coolant Engine Outlet Valve., Vol 5	WP 0727
Figure 2. Heater Coolant Engine Inlet Valve., Vol 5	WP 0727
Figure 3. HVAC 3-Way Valve., Vol 5.	WP 0727
Figure 4. 3-Way Valve Bracket Bolts., Vol 5	WP 0727
Figure 5. 3-Way Valve and Hose., Vol 5	WP 0727
Figure 6. 3-Way Valve and Hose., Vol 5	WP 0727
Figure 7. 3-Way Valve Bracket Bolts., Vol 5	WP 0727
Figure 8. HVAC 3-Way Valve., Vol 5.	WP 0727
Figure 9. Heater Coolant Engine Outlet Valve., Vol 5	WP 0727
Figure 10. Heater Coolant Engine Inlet Valve., Vol 5.	WP 0727
HEATING VENTILATING AND AIR CONDITIONING (HVAC) CABIN HEATER HOSE REMOVAL AND INSTALLATION, Vol 5	WP 0728
Figure 1. Heater Coolant Engine Outlet Valve., Vol 5	WP 0728
Figure 2. Heater Coolant Engine Inlet Valve., Vol 5	WP 0728
Figure 3. Heater Hose Connections at Floor., Vol 5	WP 0728
Figure 4. Heater Hose Connections at Life Support System (LSS) Box., Vol 5	WP 0728
Figure 5. Heater Hose Connections at Floor., Vol 5	WP 0728
Figure 6. Heater Hose Connections at LSS Box., Vol 5	WP 0728
Figure 7. Heater Coolant Engine Outlet Valve., Vol 5	WP 0728
Figure 8. Heater Coolant Engine Inlet Valve., Vol 5	WP 0728
HEATING VENTILATING AND AIR CONDITIONING (HVAC) FUEL-FIRED HEATER COOLANT OUTLET HOSE REMOVAL AND INSTALLATION, Vol 5	WP 0729
Figure 1. Heater Coolant Engine Outlet Valve., Vol 5	WP 0729
Figure 2. Heater Coolant Engine Inlet Valve., Vol 5	WP 0729
Figure 3. Hose Connections at Fuel-Fired Heater., Vol 5	WP 0729
Figure 4. Fuel-Fired Heater Outlet Hose., Vol 5	WP 0729
Figure 5. Fuel-Fired Heater Outlet Hose., Vol 5	WP 0729
Figure 6. Hose Connections at Fuel-Fired Heater., Vol 5	WP 0729
Figure 7. Heater Coolant Engine Inlet Valve Installation., Vol 5	WP 0729
Figure 8. Heater Coolant Engine Outlet Valve., Vol 5	WP 0729
HEATING VENTILATING AND AIR CONDITIONING (HVAC) 3-WAY VALVE COOLANT INLET HOSE REMOVAL AND INSTALLATION, Vol 5	WP 0730
Figure 1. Inlet Valve To Water Pump From Heater., Vol 5.	WP 0730
Figure 2. Inlet Hose To Engine From Heater., Vol 5	WP 0730
Figure 3. 3-Way Valve., Vol 5.	WP 0730
Figure 4. 3-Way Valve., Vol 5.	WP 0730
Figure 5. Inlet Hose To Engine From Heater., Vol 5	WP 0730
Figure 6. Inlet Valve To Water Pump From Heater., Vol 5.	WP 0730

TABLE OF CONTENTS – (Continued)

	Page No.
	WP Sequence No.
HEATING VENTILATING AND AIR CONDITIONING (HVAC) FUEL-FIRED HEATER COOLANT INLET HOSE REMOVAL AND INSTALLATION, Vol 5	
Figure 1. Heater Coolant Engine Outlet Valve., Vol 5	WP 0731
Figure 2. Heater Coolant Engine Inlet Valve., Vol 5	WP 0731
Figure 3. Fuel-Fired Heater Hose Connections., Vol 5	WP 0731
Figure 4. Fuel-Fired Heater Inlet Hose at Penetration Dust Plate., Vol 5	WP 0731
Figure 5. Fuel-Fired Heater Hose Tee., Vol 5	WP 0731
Figure 6. Fuel-Fired Hose Tee and Dust Plate., Vol 5	WP 0731
Figure 7. Fuel-Fired Heater Inlet Hose at 3-Way Valve., Vol 5	WP 0731
Figure 8. Fuel-Fired Heater Inlet Hose at 3-Way Valve., Vol 5	WP 0731
Figure 9. Fuel-Fired Heater Inlet Hose at Penetration Dust Plate., Vol 5	WP 0731
Figure 10. Fuel-Fired Heater Hose Tee., Vol 5	WP 0731
Figure 11. Fuel-Fired Heater Inlet Hose., Vol 5	WP 0731
Figure 12. Fuel-Fired Heater Hose Connections., Vol 5	WP 0731
Figure 13. Heater Coolant Engine Inlet Valve., Vol 5	WP 0731
Figure 14. Heater Coolant Engine Outlet Valve., Vol 5	WP 0731
FUEL-FIRED HEATER REMOVAL AND INSTALLATION, Vol 5	
Figure 1. Heater Coolant Engine Outlet Valve., Vol 5	WP 0732
Figure 2. Heater Coolant Engine Inlet Valve., Vol 5	WP 0732
Figure 3. Fuel-Fired Heater Mounted., Vol 5	WP 0732
Figure 4. Fuel-Fired Heater Coolant Hoses., Vol 5	WP 0732
Figure 5. Fuel-Fired Heater., Vol 5	WP 0732
Figure 6. Fuel-Fired Heater., Vol 5	WP 0732
Figure 7. Fuel-Fired Heater Coolant Hoses., Vol 5	WP 0732
Figure 8. Fuel-Fired Heater Mounted., Vol 5	WP 0732
Figure 9. Heater Coolant Engine Inlet Valve., Vol 5	WP 0732
Figure 10. Heater Coolant Engine Outlet Valve., Vol 5	WP 0732
Figure 11. Fuel-Fired Heater Bleed Screw., Vol 5	WP 0732
FUEL-FIRED HEATER FUEL PUMP AND FUEL LINE REMOVAL AND INSTALLATION, Vol 5	
Figure 1. Fuel Tank Connection., Vol 5	WP 0733
Figure 2. Fuel-Fired Heater Fuel Pump., Vol 5	WP 0733
Figure 3. Fuel-Fired Heater Fuel Line Connection., Vol 5	WP 0733
Figure 4. Fuel-Fired Heater Fuel Line Connection., Vol 5	WP 0733
Figure 5. Fuel-Fired Heater Fuel Pump., Vol 5	WP 0733
Figure 6. Fuel Tank Connection., Vol 5	WP 0733
FUEL FIRED HEATER AND FUEL FIRED HEATER FUEL PUMP HARNESS REMOVAL AND INSTALLATION, Vol 5	
Figure 1. Fuel Fired Heater Connector., Vol 5	WP 0734
Figure 2. Fire Suppression System (FSS) Harness., Vol 5	WP 0734
Figure 3. Frame Bracket., Vol 5	WP 0734
Figure 4. Main Harness, Right Side., Vol 5	WP 0734
Figure 5. Transmission Bellhousing., Vol 5	WP 0734
Figure 6. Fuel Fired Heater Harness., Vol 5	WP 0734
Figure 7. Fuel Pump Connector., Vol 5	WP 0734
Figure 8. Main Harness Near Starter., Vol 5	WP 0734
Figure 9. Power Distribution Center (PDC) Armor., Vol 5	WP 0734
Figure 10. Fuel Fired Heater and Fuel Fired Heater Fuel Pump Harness Connectors at PDC., Vol 5	WP 0734
Figure 11. Fuel Fired Heater and Fuel Fired Heater Fuel Pump Harness Connectors at PDC., Vol 5	WP 0734
Figure 12. PDC Armor Plate., Vol 5	WP 0734
Figure 13. Main Harness Near Starter., Vol 5	WP 0734

TABLE OF CONTENTS – (Continued)

	Page No.
	<u>WP Sequence No.</u>
Figure 14. Fuel Pump Connector., Vol 5	WP 0734
Figure 15. Fuel Fired Heater Harness., Vol 5	WP 0734
Figure 16. Transmission Bellhousing., Vol 5	WP 0734
Figure 17. Main Harness, Right Side., Vol 5	WP 0734
Figure 18. Frame Bracket., Vol 5	WP 0734
Figure 19. FSS Harness., Vol 5	WP 0734
Figure 20. Fuel Fired Heater Connector., Vol 5	WP 0734
FUEL-FIRED HEATER TIMER CONTROL REMOVAL AND INSTALLATION, Vol 5	WP 0735
Figure 1. Fuel-Fired Heater Timer Control Switch and Timer Wiring., Vol 5	WP 0735
Figure 2. Fuel-Fired Heater Timer Switch and Control., Vol 5	WP 0735
Figure 3. Fuel-Fired Heater Timer Switch and Control., Vol 5	WP 0735
Figure 4. Fuel-Fired Heater Timer Control Switch and Timer Wiring., Vol 5	WP 0735
FIRE SUPPRESSION SYSTEM (FSS) DISABLE AND ENABLE, Vol 5	WP 0736
Figure 1. Fire Suppression System (FSS) Harness Removal., Vol 5	WP 0736
FIRE SUPPRESSION SYSTEM (FSS) CONTROL UNIT REMOVAL AND INSTALLATION, Vol 5	WP 0737
Figure 1. FSS Control Unit., Vol 5	WP 0737
Figure 2. FSS Control Unit., Vol 5	WP 0737
FIRE SUPPRESSION SYSTEM (FSS) CONTROL UNIT BRACKET REMOVAL AND INSTALLATION, Vol 5	WP 0738
Figure 1. Communication Bracket., Vol 5	WP 0738
Figure 2. FSS Bracket Bolts., Vol 5	WP 0738
Figure 3. FSS Bracket Bolts., Vol 5	WP 0738
Figure 4. Communication Bracket., Vol 5	WP 0738
FIRE SUPPRESSION SYSTEM (FSS) CABIN HARNESS REMOVAL AND INSTALLATION, Vol 5	WP 0739
Figure 1. Interior Pass-Through Plate Connection., Vol 5	WP 0739
Figure 2. FSS Control Unit., Vol 5	WP 0739
Figure 3. Power Distribution Module (PDM) Harness Electrical Storage Shield and Duct Covers., Vol 5	WP 0739
Figure 4. FSS Connector., Vol 5	WP 0739
Figure 5. FSS Cabin Cylinder Connection., Vol 5	WP 0739
Figure 6. FSS Cabin Cylinder Connection., Vol 5	WP 0739
Figure 7. FSS Connector., Vol 5	WP 0739
Figure 8. PDM Harness Electrical Storage Shield and Duct Covers., Vol 5	WP 0739
Figure 9. FSS Control Unit., Vol 5	WP 0739
Figure 10. Interior Pass-Through Plate Connection., Vol 5	WP 0739
FIRE SUPPRESSION SYSTEM (FSS) CHASSIS HARNESS REMOVAL AND INSTALLA- TION, Vol 5	WP 0740
Figure 1. FSS Engine Compartment Sensor Connection., Vol 5	WP 0740
Figure 2. FSS Cylinder Connection., Vol 5	WP 0740
Figure 3. FSS Fuel Tank Extinguisher Cylinder Connection., Vol 5	WP 0740
Figure 4. FSS Tire Extinguisher Cylinder Connection., Vol 5	WP 0740
Figure 5. Interior Side of Pass-Through Plate., Vol 5	WP 0740
Figure 6. Exterior Side of Pass-Through Plate., Vol 5	WP 0740
Figure 7. Exterior Side of Pass-Through Plate., Vol 5	WP 0740
Figure 8. Interior Side of Pass-Through Plate., Vol 5	WP 0740
Figure 9. FSS Tire Extinguisher Cylinder Connection., Vol 5	WP 0740
Figure 10. FSS Fuel Tank Extinguisher Cylinder Connection., Vol 5	WP 0740
Figure 11. FSS Engine Extinguisher Cylinder Connection., Vol 5	WP 0740
Figure 12. FSS Engine Compartment Sensor Connection., Vol 5	WP 0740

TABLE OF CONTENTS – (Continued)

	Page No.
	<u>WP Sequence No.</u>
FIRE SUPPRESSION SYSTEM (FSS) ENGINE COMPARTMENT SENSOR REMOVAL AND INSTALLATION, Vol 5	WP 0741
Figure 1. FSS Engine Compartment Sensor Connections., Vol 5	WP 0741
FIRE SUPPRESSION SYSTEM (FSS) CABIN SENSOR REMOVAL AND INSTALLATION, Vol 5	WP 0742
Figure 1. FSS Cabin Compartment Sensor Connections., Vol 5	WP 0742
Figure 2. FSS Cabin Compartment Sensor Installation., Vol 5	WP 0742
FIRE SUPPRESSION SYSTEM (FSS) FUEL TANK CYLINDER REMOVAL AND INSTALLATION, Vol 5	WP 0743
Figure 1. FSS Fuel Tank Cylinder Connections., Vol 5	WP 0743
Figure 2. FSS Engine Cylinder Mount., Vol 5	WP 0743
Figure 3. FSS Fuel Tank Cylinder Mount., Vol 5	WP 0743
Figure 4. FSS Fuel Tank Cylinder Connection., Vol 5	WP 0743
FIRE SUPPRESSION SYSTEM (FSS) FUEL TANK DISPERSION UNIT AND PIPE REMOVAL AND INSTALLATION, Vol 5	WP 0744
Figure 1. Fuel Tank FSS Bracket., Vol 5	WP 0744
Figure 2. FSS Fuel Tank Dispersion Unit Hose., Vol 5	WP 0744
Figure 3. FSS Fuel Tank Dispersion Unit and Pipe, (Rear Nozzle Shown, Front Nozzle Similar), Vol 5	WP 0744
Figure 4. FSS Fuel Tank Dispersion Unit and Pipe, (Rear Nozzle Shown, Front Nozzle Similar), Vol 5	WP 0744
Figure 5. FSS Fuel Tank Dispersion Unit Hose., Vol 5	WP 0744
Figure 6. Fuel Tank FSS Bracket., Vol 5	WP 0744
FIRE SUPPRESSION SYSTEM (FSS) CABIN CYLINDER REMOVAL AND INSTALLATION, Vol 5	WP 0745
Figure 1. FSS Control Unit., Vol 5	WP 0745
Figure 2. FSS Cabin Cylinder Electrical Connector., Vol 5	WP 0745
Figure 3. FSS Cabin Cylinder Connections Shield., Vol 5	WP 0745
Figure 4. FSS Cabin Cylinder Hoses., Vol 5	WP 0745
Figure 5. FSS Cabin Cylinder Hoses., Vol 5	WP 0745
Figure 6. FSS Cabin Cylinder Connections Shield., Vol 5	WP 0745
Figure 7. FSS Cabin Cylinder Electrical Connector., Vol 5	WP 0745
Figure 8. FSS Control Unit., Vol 5	WP 0745
FIRE SUPPRESSION SYSTEM (FSS) CABIN/CREW DISPERSION UNIT AND PIPE REMOVAL AND INSTALLATION, Vol 5	WP 0746
Figure 1. Front FSS Cabin/Crew Dispersion Unit and Pipe., Vol 5	WP 0746
Figure 2. Rear FSS Cabin/Crew Dispersion Unit and Pipe (Right Side Shown, Left Side Similar), Vol 5	WP 0746
Figure 3. Rear FSS Cabin/Crew Dispersion Unit and Pipe (Right Side Shown, Left Side Similar), Vol 5	WP 0746
Figure 4. Front FSS Cabin/Crew Dispersion Unit and Pipe., Vol 5	WP 0746
FIRE SUPPRESSION SYSTEM (FSS) TIRE CYLINDER REMOVAL AND INSTALLATION, Vol 5	WP 0747
Figure 1. FSS Tire Cylinder Connections., Vol 5	WP 0747
Figure 2. FSS Tire Cylinder Connections., Vol 5	WP 0747
FIRE SUPPRESSION SYSTEM (FSS) FRONT TIRE DISPERSION UNIT AND PIPE REMOVAL AND INSTALLATION, Vol 5	WP 0748
Figure 1. FSS Front Tire Dispersion Unit and Pipe., Vol 5	WP 0748
Figure 2. FSS Front Tire Dispersion Unit and Pipe., Vol 5	WP 0748

TABLE OF CONTENTS – (Continued)

	<u>Page No.</u>
	<u>WP Sequence No.</u>
FIRE SUPPRESSION SYSTEM (FSS) REAR TIRE DISPERSION UNIT AND PIPE REMOVAL AND INSTALLATION, Vol 5	WP 0749
Figure 1. FSS Rear Tire Dispersion Unit and Pipe., Vol 5.	WP 0749
Figure 2. FSS Rear Tire Dispersion Unit and Pipe., Vol 5.	WP 0749
FIRE SUPPRESSION SYSTEM (FSS) ENGINE CYLINDER REMOVAL AND INSTALLATION, Vol 5	WP 0750
Figure 1. FSS Engine Cylinder Connections., Vol 5	WP 0750
Figure 2. FSS Engine Cylinder Mount., Vol 5	WP 0750
Figure 3. FSS Engine Cylinder Mount., Vol 5	WP 0750
Figure 4. FSS Engine Cylinder Connections., Vol 5	WP 0750
FIRE SUPPRESSION SYSTEM (FSS) ENGINE DISPERSION UNIT AND PIPE REMOVAL AND INSTALLATION, Vol 5	WP 0751
Figure 1. FSS Engine Dispersion Unit and Pipe., Vol 5.	WP 0751
Figure 2. FSS Engine Dispersion Unit and Pipe., Vol 5.	WP 0751
Figure 3. FSS Engine Dispersion Unit and Pipe., Vol 5.	WP 0751
Figure 4. FSS Engine Dispersion Unit and Pipe., Vol 5.	WP 0751
HEATING VENTILATING AND AIR CONDITIONING (HVAC)/LIFE SUPPORT SYSTEM (LSS) MAIN AIR DUCT REMOVAL AND INSTALLATION, Vol 5	WP 0752
Figure 1. Rear Seat Ratchet., Vol 5	WP 0752
Figure 2. Seat Suspension Lever Position., Vol 5	WP 0752
Figure 3. Seat Suspension Lever Release., Vol 5	WP 0752
Figure 4. Fire Suppression Fitting., Vol 5.	WP 0752
Figure 5. Wire Harness Cable Lock Strap., Vol 5	WP 0752
Figure 6. Main Air Duct Removal., Vol 5	WP 0752
Figure 7. Main Air Duct Installation., Vol 5	WP 0752
Figure 8. Fire Suppression Fitting., Vol 5.	WP 0752
Figure 9. Wire Harness Cable Lock Strap., Vol 5	WP 0752
Figure 10. Suspension Seat Shackles., Vol 5.	WP 0752
Figure 11. Seat Suspension Lever Position., Vol 5.	WP 0752
Figure 12. Seat Suspension Lever Engaged., Vol 5	WP 0752
Figure 13. Rear Seat Ratchet., Vol 5	WP 0752
HEATING VENTILATING AND AIR CONDITIONING (HVAC)/LIFE SUPPORT SYSTEM (LSS) AIR DUCT LOUVER REMOVAL AND INSTALLATION, Vol 5	WP 0753
Figure 1. Forward Facing Right Side Center Louver. , Vol 5	WP 0753
Figure 2. Rear Facing Left Side Louver., Vol 5	WP 0753
Figure 3. Rear Facing Right Side Center Louver., Vol 5	WP 0753
Figure 4. Seat Suspension Mount Clevis and Pin., Vol 5	WP 0753
Figure 5. Rear Facing Left Side Louver., Vol 5	WP 0753
Figure 6. Rear Facing Right Side Center Louver., Vol 5	WP 0753
Figure 7. Seat Suspension Mount Clevis and Pin., Vol 5	WP 0753
Figure 8. Forward Facing Right Side Center Louver., Vol 5	WP 0753
HEATING VENTILATING AND AIR CONDITIONING (HVAC)/LIFE SUPPORT SYSTEM (LSS) DEFOGGING AIR DUCT REMOVAL AND INSTALLATION, Vol 5	WP 0754
Figure 1. Defogging Air Duct Mounting., Vol 5	WP 0754
Figure 2. Defogging Air Duct Mounting., Vol 5	WP 0754
HEATING VENTILATING AND AIR CONDITIONING (HVAC)/LIFE SUPPORT SYSTEM (LSS) DIFFUSER AIR DUCT REMOVAL AND INSTALLATION, Vol 5	WP 0755
Figure 1. Diffuser Air Duct., Vol 5	WP 0755
Figure 2. Diffuser Air Duct., Vol 5	WP 0755

TABLE OF CONTENTS – (Continued)

	Page No.
	<u>WP Sequence No.</u>
HEATING VENTILATING AND AIR CONDITIONING (HVAC)/LIFE SUPPORT SYSTEM (LSS) FRESH AIR INLET FLANGE REMOVAL AND INSTALLATION, Vol 5	WP 0756
Figure 1. Fresh Air Inlet Flange., Vol 5.	WP 0756
Figure 2. Fresh Air Inlet Flange., Vol 5.	WP 0756
HEATING VENTILATING AND AIR CONDITIONING (HVAC)/LIFE SUPPORT SYSTEM (LSS) OVERPRESSURE RELIEF VALVE REMOVAL AND INSTALLATION, Vol 5	WP 0757
Figure 1. Overpressure Relief Valve Mounting., Vol 5	WP 0757
Figure 2. Overpressure Relief Valve Shield Assembly Mounting., Vol 5.	WP 0757
Figure 3. Overpressure Relief Valve Shield Assembly., Vol 5	WP 0757
Figure 4. Overpressure Relief Valve O-Ring., Vol 5	WP 0757
Figure 5. Overpressure Relief Valve Shield Assembly Mounting., Vol 5.	WP 0757
Figure 6. Overpressure Relief Valve O-Ring., Vol 5	WP 0757
Figure 7. Overpressure Relief Valve Mounting., Vol 5	WP 0757
HEATING VENTILATING AND AIR CONDITIONING (HVAC) RECEIVER/DRIER REMOVAL AND INSTALLATION, Vol 5	WP 0758
Figure 1. Inlet Hose at Evaporator Assembly., Vol 5	WP 0758
Figure 2. Inlet Hose at Receiver/Drier., Vol 5	WP 0758
Figure 3. Pressure Switch Connection., Vol 5.	WP 0758
Figure 4. Discharge Hose at Thermal Expansion Valve., Vol 5	WP 0758
Figure 5. Receiver/Drier Mounting Bolts., Vol 5	WP 0758
Figure 6. Discharge Hose at Receiver/Drier., Vol 5	WP 0758
Figure 7. High Pressure Switch., Vol 5.	WP 0758
Figure 8. Receiver/Drier Mounting Plate and Clamp., Vol 5.	WP 0758
Figure 9. Receiver/Drier Mounting Plate and Clamp., Vol 5.	WP 0758
Figure 10. High Pressure Switch., Vol 5	WP 0758
Figure 11. Discharge Hose at Receiver/Drier., Vol 5	WP 0758
Figure 12. Receiver/Drier Mounting Bolts., Vol 5	WP 0758
Figure 13. Discharge Hose at Thermal Expansion Valve., Vol 5	WP 0758
Figure 14. Pressure Switch Connection., Vol 5	WP 0758
Figure 15. Inlet Hose at Receiver/Drier., Vol 5	WP 0758
Figure 16. Inlet Hose at Evaporator Assembly., Vol 5	WP 0758
HEATING VENTILATING AND AIR CONDITIONING (HVAC) MAIN EVAPORATOR ASSEMBLY REMOVAL AND INSTALLATION, Vol 5.	WP 0759
Figure 1. Evaporator Fittings., Vol 5	WP 0759
Figure 2. Evaporator Hose With O-Ring Installed., Vol 5	WP 0759
Figure 3. HVAC Thermostat., Vol 5	WP 0759
Figure 4. Evaporator Mounting Bracket Bolts., Vol 5.	WP 0759
Figure 5. Evaporator Mounting Bracket Bolts., Vol 5.	WP 0759
Figure 6. HVAC Thermostat., Vol 5	WP 0759
Figure 7. Evaporator Hose With O-Ring Removed, Vol 5.	WP 0759
Figure 8. Evaporator Outlet Hose at Evaporator., Vol 5	WP 0759

TABLE OF CONTENTS – (Continued)

	<u>Page No.</u>
	<u>WP Sequence No.</u>
HEATING VENTILATING AND AIR CONDITIONING (HVAC) HEATER RADIATOR REMOVAL AND INSTALLATION, Vol 5	
Figure 1. Heater Coolant Engine Outlet Valve., Vol 5	WP 0760
Figure 2. Heater Coolant Engine Inlet Valve., Vol 5	WP 0760
Figure 3. Heater Radiator Outlet Fitting., Vol 5	WP 0760
Figure 4. Heater Radiator Outlet Hose Inside LSS Box at Panel., Vol 5	WP 0760
Figure 5. Heater Radiator Inlet Fitting., Vol 5	WP 0760
Figure 6. Heater Radiator Inlet Hose Inside LSS Box at Panel., Vol 5	WP 0760
Figure 7. Heater Radiator., Vol 5	WP 0760
Figure 8. Heater Radiator., Vol 5	WP 0760
Figure 9. Heater Radiator Inlet Fitting., Vol 5	WP 0760
Figure 10. Heater Radiator Inlet Hose Inside LSS Box at Panel., Vol 5	WP 0760
Figure 11. Heater Radiator Outlet Fitting., Vol 5	WP 0760
Figure 12. Heater Radiator Outlet Hose Inside LSS Box at Panel., Vol 5	WP 0760
Figure 13. Heater Coolant Engine Outlet Valve., Vol 5	WP 0760
Figure 14. Heater Coolant Engine Inlet Valve., Vol 5	WP 0760
HEATING VENTILATING AND AIR CONDITIONING (HVAC)/LIFE SUPPORT SYSTEM (LSS) BOX REMOVAL AND INSTALLATION, Vol 5	
Figure 1. Heater Coolant Engine Outlet Valve., Vol 5	WP 0761
Figure 2. Heater Coolant Engine Inlet Valve., Vol 5	WP 0761
Figure 3. Heater Hoses., Vol 5	WP 0761
Figure 4. Evaporator Inlet Hose at Evaporator., Vol 5	WP 0761
Figure 5. Evaporator Hose With O-Ring Installed., Vol 5	WP 0761
Figure 6. HVAC/LSS Box Mounting., Vol 5	WP 0761
Figure 7. HVAC Box Seal., Vol 5	WP 0761
Figure 8. HVAC/LSS Box Mounting., Vol 5	WP 0761
Figure 9. Blower Harness Routing., Vol 5	WP 0761
Figure 10. Evaporator Hose With O-Ring Removed, Vol 5	WP 0761
Figure 11. Evaporator Outlet Hose at Evaporator., Vol 5	WP 0761
Figure 12. Heater Hoses., Vol 5	WP 0761
Figure 13. Heater Coolant Engine Outlet Valve., Vol 5	WP 0761
Figure 14. Heater Coolant Engine Inlet Valve., Vol 5	WP 0761
NUCLEAR, BIOLOGICAL, AND CHEMICAL (NBC) FILTER REMOVAL AND INSTALLATION, Vol 5 WP 0762	
Figure 1. NBC Access Door., Vol 5	WP 0762
Figure 2. NBC Filter Cover., Vol 5	WP 0762
Figure 3. NBC Filter in NBC Filter Housing., Vol 5	WP 0762
Figure 4. NBC Filter Installation., Vol 5	WP 0762
Figure 5. NBC Filter Cover., Vol 5	WP 0762
Figure 6. NBC Access Door., Vol 5	WP 0762
NUCLEAR, BIOLOGICAL, AND CHEMICAL (NBC) FILTER COVER AND HOUSING REMOVAL AND INSTALLATION, Vol 5	
Figure 1. NBC Filter Cover., Vol 5	WP 0763
Figure 2. NBC Filter Housing., Vol 5	WP 0763
Figure 3. NBC Filter Outlet Tube., Vol 5	WP 0763
Figure 4. NBC Filter Outlet Tube., Vol 5	WP 0763
Figure 5. NBC Filter Housing., Vol 5	WP 0763
Figure 6. NBC Filter Cover., Vol 5	WP 0763

TABLE OF CONTENTS – (Continued)

	Page No.
	<u>WP Sequence No.</u>
NUCLEAR, BIOLOGICAL, AND CHEMICAL (NBC) PARTICLE SEPARATOR FILTER REMOVAL AND INSTALLATION, Vol 5	WP 0764
Figure 1. NBC Particle Separator Filter Mounting., Vol 5	WP 0764
Figure 2. NBC Particle Separator Filter., Vol 5	WP 0764
Figure 3. NBC Particle Separator Filter., Vol 5	WP 0764
Figure 4. NBC Particle Separator Filter Mounting., Vol 5	WP 0764
HEATING VENTILATING AND AIR CONDITIONING (HVAC)/LIFE SUPPORT SYSTEM (LSS) MAIN BLOWER MOTOR AND SUPPORT REMOVAL AND INSTALLATION, Vol 5	WP 0765
Figure 1. HVAC/LSS Main Blower Motor., Vol 5	WP 0765
Figure 2. HVAC/LSS Main Blower Motor., Vol 5	WP 0765
HEATING VENTILATING AND AIR CONDITIONING/LIFE SUPPORT SYSTEM (HVAC/LSS) UPPER BLOWER REMOVAL AND INSTALLATION, Vol 5	WP 0766
Figure 1. Blower Mounting Panel., Vol 5	WP 0766
Figure 2. Blower Harness Connector., Vol 5	WP 0766
Figure 3. Fan Drive Setscrew., Vol 5	WP 0766
Figure 4. Blower Motor and Mounting Panel., Vol 5	WP 0766
Figure 5. Blower Mounting Panel., Vol 5	WP 0766
Figure 6. Blower Harness Connector., Vol 5	WP 0766
HEATING VENTILATING AND AIR CONDITIONING/LIFE SUPPORT SYSTEM (HVAC/LSS) UPPER PANEL REMOVAL AND INSTALLATION, Vol 5	WP 0767
Figure 1. HVAC Cover Panel., Vol 5	WP 0767
Figure 2. HVAC Cover Panel., Vol 5	WP 0767
HEATING VENTILATING AND AIR CONDITIONING (HVAC) RECIRCULATED AIR (RA) TEMPERATURE SENSOR REMOVAL AND INSTALLATION, Vol 5	WP 0768
Figure 1. RA Sensor Connector., Vol 5	WP 0768
Figure 2. LSS Operator Panel Connector., Vol 5	WP 0768
Figure 3. RA Sensor Bolts., Vol 5	WP 0768
Figure 4. RA Sensor Bolts., Vol 5	WP 0768
Figure 5. RA Sensor Connector., Vol 5	WP 0768
Figure 6. LSS Operator Panel Connector., Vol 5	WP 0768
CLIMATE CONTROL UNIT (CCU) BOX REMOVAL AND INSTALLATION, Vol 5.	WP 0769
Figure 1. CCU Box Upper Connections., Vol 5	WP 0769
Figure 2. CCU Box Lower Connections., Vol 5	WP 0769
Figure 3. CCU Box Ground., Vol 5	WP 0769
Figure 4. CCU Box Mounting., Vol 5.	WP 0769
Figure 5. CCU Box Side Connector., Vol 5	WP 0769
Figure 6. CCU Box Side Connector., Vol 5	WP 0769
Figure 7. CCU Box Mounting., Vol 5.	WP 0769
Figure 8. CCU Box Lower Connections., Vol 5	WP 0769
Figure 9. CCU Box Ground., Vol 5	WP 0769
Figure 10. CCU Box Upper Connections., Vol 5.	WP 0769
HEATING VENTILATING AND AIR CONDITIONING (HVAC)/LIFE SUPPORT SYSTEM (LSS) OPERATOR PANEL REMOVAL AND INSTALLATION, Vol 5	WP 0770
Figure 1. LSS Operator Panel., Vol 5	WP 0770
Figure 2. LSS Operator Panel Housing., Vol 5	WP 0770
Figure 3. LSS Operator Panel Wiring Harness., Vol 5	WP 0770
Figure 4. LSS Operator Panel Wiring Harness., Vol 5	WP 0770
Figure 5. LSS Operator Panel Housing., Vol 5	WP 0770
Figure 6. LSS Operator Panel., Vol 5	WP 0770

TABLE OF CONTENTS – (Continued)

	<u>Page No.</u>
	<u>WP Sequence No.</u>
HEATING VENTILATING AND AIR CONDITIONING (HVAC) LOW PRESSURE SWITCH REMOVAL AND INSTALLATION, Vol 5	WP 0771
Figure 1. HVAC Low Pressure Switch., Vol 5	WP 0771
Figure 2. HVAC Low Pressure Switch., Vol 5	WP 0771
HEATING VENTILATING AND AIR CONDITIONING (HVAC) LEFT CONDENSER CONTROL WIRING HARNESS REMOVAL AND INSTALLATION, Vol 5	WP 0772
Figure 1. Left Condenser., Vol 5	WP 0772
Figure 2. Left Condenser Harness Connectors., Vol 5	WP 0772
Figure 3. Left Condenser., Vol 5	WP 0772
Figure 4. Left Condenser Harness Connectors., Vol 5	WP 0772
HEATING VENTILATING AND AIR CONDITIONING (HVAC) RIGHT CONDENSER CONTROL WIRING HARNESS REMOVAL AND INSTALLATION, Vol 5	WP 0773
Figure 1. Right Condenser., Vol 5	WP 0773
Figure 2. Right Condenser Harness Connectors., Vol 5	WP 0773
Figure 3. Right Condenser., Vol 5	WP 0773
Figure 4. Right Condenser Harness Connectors., Vol 5	WP 0773
HEATING VENTILATING AND AIR CONDITIONING (HVAC)/LIFE SUPPORT SYSTEM (LSS) ENGINE WIRING HARNESS REMOVAL AND INSTALLATION, Vol 5	WP 0774
Figure 1. Interior Penetration Plate., Vol 5	WP 0774
Figure 2. Interior HVAC/LSS Wiring Harness., Vol 5	WP 0774
Figure 3. Penetration Plate., Vol 5	WP 0774
Figure 4. HVAC/LSS Engine Harness O-Ring., Vol 5	WP 0774
Figure 5. 3-Way Valve., Vol 5	WP 0774
Figure 6. High Idle Request Circuit Connector., Vol 5	WP 0774
Figure 7. Low Pressure Switch Connector., Vol 5	WP 0774
Figure 8. Low Pressure Switch Connector., Vol 5	WP 0774
Figure 9. High Idle Request Circuit Connector., Vol 5	WP 0774
Figure 10. 3-Way Valve., Vol 5	WP 0774
Figure 11. HVAC/LSS Engine Harness O-Ring., Vol 5	WP 0774
Figure 12. Penetration Plate., Vol 5	WP 0774
Figure 13. Interior HVAC/LSS Wiring Harness., Vol 5	WP 0774
Figure 14. Interior Penetration Plate., Vol 5	WP 0774
HEATING VENTILATING AND AIR CONDITIONING (HVAC) CONTROL INPUT WIRING HARNESS REMOVAL AND INSTALLATION, Vol 5	WP 0775
Figure 1. HVAC/LSS Control Input Wiring Harness Connections at Climate Control Unit (CCU) Box., Vol 5	WP 0775
Figure 2. Right HVAC Channel Cover., Vol 5	WP 0775
Figure 3. Rear HVAC Channel Cover., Vol 5	WP 0775
Figure 4. HVAC Condenser Relay Harness Connector., Vol 5	WP 0775
Figure 5. HVAC Condenser Relay Harness Connector., Vol 5	WP 0775
Figure 6. Rear HVAC Channel Cover., Vol 5	WP 0775
Figure 7. Right HVAC Channel Cover., Vol 5	WP 0775
Figure 8. HVAC/LSS Control Input Wiring Harness Connections at Climate Control Unit (CCU) Box., Vol 5	WP 0775

TABLE OF CONTENTS – (Continued)

	Page No.
	WP Sequence No.
HEATING VENTILATING AND AIR CONDITIONING (HVAC) CONTROL 2 WIRING HARNESS REMOVAL AND INSTALLATION, Vol 5	
Figure 1. Interior Pass-Through Plate., Vol 5	WP 0776
Figure 2. Interior HVAC Control 2 Wiring Harness Connector., Vol 5	WP 0776
Figure 3. Exterior Pass-Through Plate., Vol 5	WP 0776
Figure 4. HVAC Control 2 Wiring Harness O-Ring., Vol 5	WP 0776
Figure 5. Left Condenser Harness Connectors., Vol 5	WP 0776
Figure 6. Right Condenser Harness Connectors., Vol 5	WP 0776
Figure 7. HVAC Compressor Connector., Vol 5	WP 0776
Figure 8. HVAC Compressor Harness Connector., Vol 5	WP 0776
Figure 9. Left Condenser Connectors., Vol 5	WP 0776
Figure 10. Right Condenser Connectors., Vol 5	WP 0776
Figure 11. HVAC Control 2 Harness O-Ring., Vol 5	WP 0776
Figure 12. Exterior Pass-Through Plate., Vol 5	WP 0776
Figure 13. Interior HVAC Wiring Harness Connector., Vol 5	WP 0776
Figure 14. Interior Pass-Through Plate., Vol 5	WP 0776
HEATING VENTILATING AND AIR CONDITIONING (HVAC)/LIFE SUPPORT SYSTEM (LSS) CONTROL POWER WIRING HARNESS REMOVAL AND INSTALLATION, Vol 5	
Figure 1. HVAC/LSS Control Power Wiring Harness Connection at Climate Control Unit (CCU) Box., Vol 5	WP 0777
Figure 2. Rear HVAC Channel Cover., Vol 5	WP 0777
Figure 3. Electrical Harness Storage Duct Cover., Vol 5	WP 0777
Figure 4. Power Distribution Module (PDM) Harness Electrical Storage Shield., Vol 5	WP 0777
Figure 5. HVAC/LSS Control Power Wiring Harness Connection at PDM., Vol 5	WP 0777
Figure 6. HVAC/LSS Control Power Wiring Harness Routing with Mechanic's Wire., Vol 5	WP 0777
Figure 7. HVAC/LSS Control Power Wiring Harness Routing with Mechanic's Wire., Vol 5	WP 0777
Figure 8. HVAC/LSS Control Power Wiring Harness Connection at Circuit Breaker Panel., Vol 5	WP 0777
Figure 9. HVAC/LSS Control Power Wiring Harness Connection at CCU Box., Vol 5	WP 0777
Figure 10. Power Distribution Module (PDM) Harness Electrical Storage Shield., Vol 5	WP 0777
Figure 11. Electrical Harness Storage Duct Cover., Vol 5	WP 0777
Figure 12. Rear HVAC Channel Cover., Vol 5	WP 0777
HEATING VENTILATING AND AIR CONDITIONING (HVAC)/LIFE SUPPORT SYSTEM (LSS) MAIN BLOWER MOTOR WIRING HARNESS REMOVAL AND INSTALLATION, Vol 5	
Figure 1. HVAC/LSS Main Blower Motor Wiring Harness., Vol 5	WP 0778
Figure 2. HVAC/LSS Main Blower Motor Wiring Harness., Vol 5	WP 0778
HEATING VENTILATING AND AIR CONDITIONING (HVAC)/LIFE SUPPORT SYSTEM (LSS) UPPER BLOWER WIRING HARNESS REMOVAL AND INSTALLATION, Vol 5	
Figure 1. HVAC/LSS Upper Blower Wiring Harness at Climate Control Unit (CCU) Box., Vol 5	WP 0779
Figure 2. HVAC/LSS Upper Blower Wiring Harness at Upper HVAC/LSS Blower., Vol 5	WP 0779
Figure 3. HVAC/LSS Upper Blower Wiring Harness Routing., Vol 5	WP 0779
Figure 4. HVAC/LSS Upper Blower Wiring Harness at Upper HVAC/LSS Blower., Vol 5	WP 0779
Figure 5. HVAC/LSS Upper Blower Wiring Harness Routing., Vol 5	WP 0779
Figure 6. HVAC/LSS Upper Blower Wiring Harness at CCU Box., Vol 5	WP 0779

TABLE OF CONTENTS – (Continued)

	Page No.
	<u>WP Sequence No.</u>
HEATING VENTILATING AND AIR CONDITIONING (HVAC)/LIFE SUPPORT SYSTEM (LSS) CONTROL	
WIRING HARNESS REMOVAL AND INSTALLATION, Vol 5	WP 0780
Figure 1. HVAC/LSS Control Wiring Harness at Climate Control Unit (CCU) Box., Vol 5	WP 0780
Figure 2. HVAC/LSS Control Wiring Harness Mounting., Vol 5	WP 0780
Figure 3. HVAC Trinary Pressure Switch Connection., Vol 5	WP 0780
Figure 4. HVAC/LSS Control Wiring Harness Routing., Vol 5	WP 0780
Figure 5. HVAC/LSS Control Wiring Harness Routing., Vol 5	WP 0780
Figure 6. HVAC Trinary Pressure Switch Connection., Vol 5	WP 0780
Figure 7. HVAC/LSS Control Wiring Harness Mounting., Vol 5	WP 0780
Figure 8. HVAC/LSS Control Wiring Harness at CCU Box., Vol 5	WP 0780
PREPARATION FOR STORAGE OR SHIPMENT, Vol 5	WP 0781
GENERAL MAINTENANCE, Vol 5.	WP 0782
LUBRICATION INSTRUCTIONS, Vol 5	WP 0783
Figure 1. Body Overview., Vol 5	WP 0783
Figure 2. Chassis Overview., Vol 5	WP 0783
Figure 3. Front Axle., Vol 5.	WP 0783
Figure 4. Oil Filter., Vol 5	WP 0783
Figure 5. Engine Oil Pan., Vol 5	WP 0783
Figure 6. Engine Oil Dipstick, Transmission Fluid Dipstick, and Power Steering Reservoir., Vol 5	WP 0783
Figure 7. Transmission Drain., Vol 5.	WP 0783
Figure 8. Drag Link., Vol 5	WP 0783
Figure 9. Pintle Hook., Vol 5	WP 0783
Figure 10. Left Upper King Pin and Inner S-Camshaft (Right Similar)., Vol 5	WP 0783
Figure 11. Left Lower King Pin (Right Similar)., Vol 5	WP 0783
Figure 12. Left Front Outer S-Camshaft (Right Similar)., Vol 5	WP 0783
Figure 13. Left Front Slack Adjuster (Right Similar)., Vol 5	WP 0783
Figure 14. Rear Axle., Vol 5	WP 0783
Figure 15. Rear Door Hydraulic Fluid Reservoir., Vol 5.	WP 0783
Figure 16. Rear Door Hydraulic Cylinder at Door., Vol 5	WP 0783
Figure 17. Rear Door Hydraulic Cylinder Upper Pivot., Vol 5	WP 0783
Figure 18. Left Rear Door Lock (Right Similar)., Vol 5	WP 0783
Figure 19. Right Rear Slack Adjuster (Left Similar)., Vol 5	WP 0783
Figure 20. Right Outer S-Camshaft (Left Similar)., Vol 5	WP 0783
Figure 21. Intermediate Steering Shaft, Upper., Vol 5	WP 0783
Figure 22. Intermediate Steering Shaft, Lower., Vol 5	WP 0783
Figure 23. Left Tie Rod End (Right Similar)., Vol 5.	WP 0783
Figure 24. Intermediate Propeller Shaft, Rear., Vol 5	WP 0783
Figure 25. Intermediate Propeller Shaft, Front., Vol 5	WP 0783
Figure 26. Transfer Case., Vol 5	WP 0783
Figure 27. Front and Rear Propeller Shafts — Two Universals Each., Vol 5.	WP 0783
Figure 28. Left Door Latches and Striker, Upper., Vol 5	WP 0783
Figure 29. Left Door Hinge, Upper., Vol 5	WP 0783
Figure 30. Right Front Stowage Compartment (Left Similar)., Vol 5	WP 0783
Figure 31. Right Rear Stowage Compartment (Left Similar)., Vol 5	WP 0783
Figure 32. Winch Cable., Vol 5	WP 0783
Figure 33. Rear Wheel Bearings., Vol 5	WP 0783
Figure 34. Front Wheel Bearings., Vol 5	WP 0783
Figure 35. Engine Coolant., Vol 5	WP 0783
Table 1. Lubrication Schedule., Vol 5	WP 0783

TABLE OF CONTENTS – (Continued)

	Page No.
	WP Sequence No.
ILLUSTRATED LIST OF MANUFACTURED ITEMS INTRODUCTION, Vol 5	WP 0784
Table 2. Index of Manufactured Items., Vol 5	WP 0784
ILLUSTRATED LIST OF MANUFACTURED ITEMS, Vol 5	WP 0785
Figure 1. Hose., Vol 5	WP 0785
Figure 2. Conduit., Vol 5	WP 0785
Figure 3. Hose., Vol 5	WP 0785
Figure 4. Insulator., Vol 5	WP 0785
Figure 5. Hose., Vol 5	WP 0785
Figure 6. Tube., Vol 5	WP 0785
Figure 7. Conduit., Vol 5	WP 0785
Figure 8. Hose Insulator., Vol 5	WP 0785
Figure 9. Hose., Vol 5	WP 0785
Figure 10. Hose., Vol 5	WP 0785
Figure 11. Tube., Vol 5	WP 0785
Figure 12. Conduit., Vol 5	WP 0785
Figure 13. Hose Insulator., Vol 5	WP 0785
Figure 14. Washer Supply Hose., Vol 5	WP 0785
Figure 15. Hose., Vol 5	WP 0785
Figure 16. Copper Tube., Vol 5	WP 0785
Figure 17. Breather Hose., Vol 5	WP 0785
Figure 18. Nonmetallic Nylon Tube., Vol 5	WP 0785
Figure 19. Power Steering Hose Armor., Vol 5	WP 0785
Figure 20. Hose., Vol 5	WP 0785
Figure 21. Conduit., Vol 5	WP 0785
Figure 22. Hood Seal., Vol 5	WP 0785
Figure 23. Foam Trim Tape., Vol 5	WP 0785
Figure 24. Power Mirror Harness Conduit., Vol 5	WP 0785
Figure 25. Fuel Line Conduit., Vol 5	WP 0785
Figure 26. Storage Box Door Seal., Vol 5	WP 0785
Figure 27. C-Channel Trim Molding., Vol 5	WP 0785
Figure 28. Fittings, Conduit, and Hose., Vol 5	WP 0785
Figure 29. Conduit., Vol 5	WP 0785
Figure 30. Hose Sleeve., Vol 5	WP 0785
Table 1. Material., Vol 5	WP 0785
Table 2. Hose and Conduit Lengths., Vol 5	WP 0785
Table 3. HVAC Hose Assemblies., Vol 5	WP 0785
Table 4. Material., Vol 5	WP 0785
Table 5. Material., Vol 5	WP 0785
Table 6. Material., Vol 5	WP 0785
Table 7. Material., Vol 5	WP 0785
Table 8. Material., Vol 5	WP 0785
Table 9. Material., Vol 5	WP 0785
Table 10. Material., Vol 5	WP 0785
Table 11. Material., Vol 5	WP 0785
Table 12. Material., Vol 5	WP 0785
Table 13. Material., Vol 5	WP 0785
Table 14. Material., Vol 5	WP 0785
Table 15. Material., Vol 5	WP 0785
Table 16. Nylon Tube Lengths., Vol 5	WP 0785
Table 17. Material., Vol 5	WP 0785
Table 18. Material., Vol 5	WP 0785
Table 19. Material., Vol 5	WP 0785

TABLE OF CONTENTS – (Continued)

	Page No.
	WP Sequence No.
Table 20. Material., Vol 5	WP 0785
Table 21. Material., Vol 5	WP 0785
Table 22. Material., Vol 5	WP 0785
Table 23. Material., Vol 5	WP 0785
Table 24. Material., Vol 5	WP 0785
Table 25. Material., Vol 5	WP 0785
Table 26. Material., Vol 5	WP 0785
Table 27. Material., Vol 5	WP 0785
TORQUE LIMITS, Vol 5	WP 0786
Figure 1. Standard and Metric Fastener Markings., Vol 5.	WP 0786
Figure 2. Standard Fastener Grades., Vol 5	WP 0786
Figure 3. Measuring Fastener., Vol 5	WP 0786
Table 1. Torque Limits for Dry Fasteners., Vol 5.	WP 0786
Table 2. Torque Limits for Wet Fasteners., Vol 5	WP 0786
Table 3. Torque Limits for Metric Fasteners., Vol 5	WP 0786
SCHEMATIC INTRODUCTION, Vol 5	WP 0787
Figure 1. Circuit Diagram Instructions., Vol 5	WP 0787
Figure 2. Circuit Identification and Location Chart (1 of 4)., Vol 5	WP 0787
Figure 3. Circuit Identification and Location Chart (2 of 4)., Vol 5	WP 0787
Figure 4. Circuit Identification and Location Chart (3 of 4)., Vol 5	WP 0787
Figure 5. Circuit Identification and Location Chart (4 of 4)., Vol 5	WP 0787
Figure 6. Symbols., Vol 5	WP 0787
Figure 7. Relay Functions., Vol 5	WP 0787
Figure 8. Abbreviations., Vol 5	WP 0787
CONNECTOR LOCATIONS, Vol 5	WP 0788
Table 1. Connector Locations, Vol 5.	WP 0788
ELECTRICAL SYSTEM SCHEMATICS, Vol 5.	WP 0789
Figure 1. CH2_01, J1708 Data Link., Vol 5.	WP 0789
Figure 2. CH2_02, J1939 Data Link – Cabin., Vol 5	WP 0789
Figure 3. CH2_03, J1939 Data Link – Chassis., Vol 5	WP 0789
Figure 4. CH3_01, Master Power Disconnect Switch., Vol 5	WP 0789
Figure 5. CH3_02, 12V Ignition Feed – Cabin (1 of 2)., Vol 5	WP 0789
Figure 6. CH3_03, 12V Ignition Feed – Cabin (2 of 2)., Vol 5.	WP 0789
Figure 7. CH3_04, 12V Ignition Feed – Chassis., Vol 5	WP 0789
Figure 8. CH3_05, 12V Battery Feed – Cabin. , Vol 5	WP 0789
Figure 9. CH3_06, 12V Battery Feed – Chassis., Vol 5	WP 0789
Figure 10. CH3_07, 12V Accessory Feed., Vol 5	WP 0789
Figure 11. CH3_08, Grounds – Instrument Panel (IP) (1 of 2)., Vol 5.	WP 0789
Figure 12. CH3_09, Grounds – IP (2 of 2). , Vol 5.	WP 0789
Figure 13. CH3_10, Grounds – Chassis., Vol 5	WP 0789
Figure 14. CH3_11, 24V Battery Feed – Cabin., Vol 5	WP 0789
Figure 15. CH3_12, 24V Battery Feed – Chassis., Vol 5	WP 0789
Figure 16. CH3_13, 24V Power Distribution Module (PDM)., Vol 5	WP 0789
Figure 17. CH3_14, CEC Engine and Transmission Clean Power and Ground., Vol 5	WP 0789
Figure 18. CH4_01, 24V Cranking and Charging Circuits – I6 HEUI Engine., Vol 5	WP 0789
Figure 19. CH4_02, 24V Alternator Ignition., Vol 5	WP 0789
Figure 20. CH5_01, Horn – Dual Electric., Vol 5	WP 0789
Figure 21. CH5_02, Power and Heated Mirrors., Vol 5	WP 0789
Figure 22. CH5_02A, Heated Windshield., Vol 5	WP 0789
Figure 23. CH5_03, Windshield Wiper Motor., Vol 5	WP 0789
Figure 24. CH5_03A, Windshield Wiper Washer Pump., Vol 5	WP 0789
Figure 25. CH5_04, Switch Pack., Vol 5	WP 0789

TABLE OF CONTENTS – (Continued)

	Page No.
	WP Sequence No.
Figure 26. CH5_05, 12V Power Sockets., Vol 5	WP 0789
Figure 27. CH5_06, Hydraulic Ramp Control – First Production., Vol 5.	WP 0789
Figure 28. CH5_06A, Hydraulic Ramp Control – Second Production., Vol 5.	WP 0789
Figure 29. CH5_07, Fire Suppression System (FSS) Control., Vol 5	WP 0789
Figure 30. CH5_08, Government Furnished Equipment (GFE) Power., Vol 5	WP 0789
Figure 31. CH5_09, Turret Power., Vol 5	WP 0789
Figure 32. CH06_01, Instrument Panel Gauge List., Vol 5	WP 0789
Figure 33. CH06_02, Instrument Panel Warning Light List., Vol 5	WP 0789
Figure 34. CH06_03, Warning Lights Controlled by Engine, Transmission, and Antilock Brake System (ABS) Controller., Vol 5	WP 0789
Figure 35. CH6_05, Gauge Cluster., Vol 5	WP 0789
Figure 36. CH6_06, Air Pressure Input Circuits., Vol 5	WP 0789
Figure 37. CH6_07, Fuel Gauge Input Circuit., Vol 5.	WP 0789
Figure 38. CH6_08, Air Park Brake Warning Light., Vol 5.	WP 0789
Figure 39. CH6_09, Warning Light – Transfer Case., Vol 5	WP 0789
Figure 40. CH6_10, 24V Meter., Vol 5	WP 0789
Figure 41. CH7_01, Air Dryer., Vol 5	WP 0789
Figure 42. CH7_02, Air – Antilock Brake System (1 of 2)., Vol 5.	WP 0789
Figure 43. CH7_03, Air – Antilock Brake System (2 of 2)., Vol 5.	WP 0789
Figure 44. CH7_04, Air Solenoid 4-Way Pack., Vol 5	WP 0789
Figure 45. CH7_05, Fuel Water Separator with 12V Fuel Pre-Heater and Water Probe., Vol 5.	WP 0789
Figure 46. CH7_06, Fuel-Fired Heater., Vol 5.	WP 0789
Figure 47. CH7_07, 110V AC Power., Vol 5	WP 0789
Figure 48. CH7_08, Winch Power Cables., Vol 5	WP 0789
Figure 49. CH7_09, Trailer Sockets – Front and Rear., Vol 5	WP 0789
Figure 50. CH7_10, Trailer ABS Center Pin Auxiliary Power., Vol 5	WP 0789
Figure 51. CH8_01, Master Vehicle Light Switch (MVLS) and Panel Light Feed., Vol 5.	WP 0789
Figure 52. CH8_02, Service Headlights., Vol 5	WP 0789
Figure 53. CH8_03, Service Backup Lights., Vol 5	WP 0789
Figure 54. CH8_04, Service Lights – Front Marker Lights., Vol 5	WP 0789
Figure 55. CH8_04A, Service Lights – Rear Marker and Taillights with Trailer Sockets., Vol 5 WP 0789	WP 0789
Figure 56. CH8_05, Service Lights – Clearance., Vol 5	WP 0789
Figure 57. CH8_06, Service Lights – Turn Signal and Stop Light Relays and Switch., Vol 5 WP 0789	WP 0789
Figure 58. CH8_07, Service Lights – Front Turn Signal Lights., Vol 5	WP 0789
Figure 59. CH8_08, Service Lights – Left Rear Turn and Stop Light with Trailer Sockets., Vol 5.	WP 0789
Figure 60. CH8_09, Service Lights – Right Rear Turn and Stop Light with Trailer Sockets., Vol 5.	WP 0789
Figure 61. CH8_10, Dome Lights., Vol 5	WP 0789
Figure 62. CH8_11, Infrared Driving Light., Vol 5	WP 0789
Figure 63. CH8_12, Blackout Driving Light., Vol 5	WP 0789
Figure 64. CH8_13, Blackout Marker and Taillights with Trailer Sockets., Vol 5	WP 0789
Figure 65. CH8_14, Blackout Stop Lights with Trailer Sockets., Vol 5	WP 0789
Figure 66. CH8_15, Remote Control Spotlight Power., Vol 5	WP 0789
Figure 67. CH8_16, Trailer Stop Lights with Trailer Sockets., Vol 5	WP 0789
Figure 68. CH9_01, I6 – HEUI Engine Controls., Vol 5.	WP 0789
Figure 69. CH9_02, I6 - HEUI Engine Controls – Cruise Control., Vol 5	WP 0789
Figure 70. CH9_03, I6 - HEUI Engine Fan and Wiring with Air Clutch., Vol 5	WP 0789
Figure 71. CH9_04, I6 - HEUI Engine – Ether Start., Vol 5	WP 0789
Figure 72. CH10_01, Allison WTEC Transmission (1 of 3)., Vol 5	WP 0789
Figure 73. CH10_02, Allison WTEC Transmission (2 of 3)., Vol 5	WP 0789
Figure 74. CH10_03 Allison WTEC Transmission (3 of 3)., Vol 5	WP 0789

TABLE OF CONTENTS – (Continued)

	Page No.
	WP Sequence No.
Figure 75. CH11_01, HVAC, Cabin (1 of 2)., Vol 5.	WP 0789
Figure 76. CH11_02, HVAC, Cabin (2 of 2)., Vol 5.	WP 0789
Figure 77. CH11_03, HVAC – Engine Compartment., Vol 5.	WP 0789
Figure 78. I6 - HEUI Engine Controls - Injector Harness., Vol 5	WP 0789
Figure 79. I6 - HEUI Engine Controls - Engine Sensor Harness., Vol 5.	WP 0789
Figure 80. Power Distribution Function Diagram., Vol 5	WP 0789
CONNECTOR COMPOSITES, Vol 5.	WP 0790
Figure 1. Connector Composites (254M, 1002)., Vol 5	WP 0790
Figure 2. Connector Composites (1003, 1010)., Vol 5	WP 0790
Figure 3. Connector Composites (1011)., Vol 5	WP 0790
Figure 4. Connector Composites (1012)., Vol 5	WP 0790
Figure 5. Connector Composites (1013)., Vol 5	WP 0790
Figure 6. Connector Composites (1014)., Vol 5	WP 0790
Figure 7. Connector Composites (1018, 1019, 1050, 1051)., Vol 5	WP 0790
Figure 8. Connector Composites (1052, 1053, 1054, 1055, 1100M, 1101M)., Vol 5	WP 0790
Figure 9. Connector Composites (1111, 1112, 1150, 1250, 1500, 1520)., Vol 5	WP 0790
Figure 10. Connector Composites (1521, 1555M, 1600, 1601)., Vol 5	WP 0790
Figure 11. Connector Composites (1650, 1658)., Vol 5.	WP 0790
Figure 12. Connector Composites (1701)., Vol 5	WP 0790
Figure 13. Connector Composites (1701)., Vol 5	WP 0790
Figure 14. Connector Composites (1703F, 1703M, 1800, 1804)., Vol 5.	WP 0790
Figure 15. Connector Composites (1805, 1808, 1809, 1810, 1811, 1812, 1813)., Vol 5.	WP 0790
Figure 16. Connector Composites (1822, 1823, 1824, 1850, 1851, 1852, 1852B, 1862)., Vol 5.	WP 0790
Figure 17. Connector Composites (1876, 1877, 1878, 1936, 1937, 1938)., Vol 5	WP 0790
Figure 18. Connector Composites (1939, 1940, 1951, 1952, 1953, 1954)., Vol 5	WP 0790
Figure 19. Connector Composites (1955, 1956, 2050, 2101, 2118, 2400)., Vol 5	WP 0790
Figure 20. Connector Composites (2401, 2500, 2501, 3000M, 3003M)., Vol 5	WP 0790
Figure 21. Connector Composites (4001)., Vol 5	WP 0790
Figure 22. Connector Composites (4002)., Vol 5	WP 0790
Figure 23. Connector Composites (4003)., Vol 5	WP 0790
Figure 24. Connector Composites (4004, 4005, 4006, 4006A, 4007, 4008)., Vol 5.	WP 0790
Figure 25. Connector Composites (4015, 4019, 4021, 4025, 4028A, 4028C, 4034, 4035, 4036)., Vol 5.	WP 0790
Figure 26. Connector Composites (4042, 4043, 4100F, 4101M)., Vol 5.	WP 0790
Figure 27. Connector Composites (4103, 4105, 4111M)., Vol 5	WP 0790
Figure 28. Connector Composites (4300, 4301)., Vol 5	WP 0790
Figure 29. Connector Composites (4305M, 4305F, 4705F1, 4705F2,)., Vol 5	WP 0790
Figure 30. Connector Composites (4811, 4830, 4840, 4900, 4910)., Vol 5	WP 0790
Figure 31. Connector Composites (4953, 4954, 6007)., Vol 5.	WP 0790
Figure 32. Connector Composites (6102, 6103, 6104, 6105, 6106, 6108, 6109, 6302, 6306, 6307)., Vol 5.	WP 0790
Figure 33. Connector Composites (6308, 6309, 6316, 6321, 6322, 6323M, 6323F, 6401M, 6401F)., Vol 5	WP 0790
Figure 34. Connector Composites (6502, 6503, 6550M, 6703, 6704, 7104F, 7104M)., Vol 5 WP 0790	WP 0790
Figure 35. Connector Composites (7150F, 7205F, 7206M)., Vol 5	WP 0790
Figure 36. Connector Composites (7208M, 7210, 7250F, 7603M, 7605M, 7611)., Vol 5	WP 0790
Figure 37. Connector Composites (8000, 8001, 8153F, 8153FR, 8154, 8154R, 8311, 8312)., Vol 5.	WP 0790
Figure 38. Connector Composites (8400B, 8500, 8501, 8502A, 8503A, 8600, 8800, 8801)., Vol 5.	WP 0790
Figure 39. Connector Composites (8802, 8803, 9100, 9250, 9251, 9254, 9255)., Vol 5.	WP 0790

TABLE OF CONTENTS – (Continued)

	Page No.
	<u>WP Sequence No.</u>
Figure 40. Connector Composites (9256, 9257, 9260M, 9260F, 9261M, 9261F, 9303A), Vol 5	WP 0790
Figure 41. Connector Composites (9501, 9502, 9503, 9504, 9700), Vol 5	WP 0790
Figure 42. Connector Composites (9714, 9715, 9715M), Vol 5	WP 0790
Figure 43. Connector Composites (9715, 9715F, 9716P, 9716F, 9716, 9716M), Vol 5	WP 0790
Figure 44. Connector Composites (9717, 9717F, 9717M, 9720, 9722, 9723, 9724), Vol 5	WP 0790
Figure 45. Connector Composites (9733, 9733P, 9736, 9750, 9754, 9755, 9778F, 9779F), Vol 5	WP 0790
Figure 46. Connector Composites (9780M, 9783, 9800F, 9800M), Vol 5	WP 0790
Figure 47. Connector Composites (9900C, 9916, 9917), Vol 5	WP 0790
Figure 48. Connector Composites (C1, C2, C3, C4, C6, C7), Vol 5	WP 0790
Figure 49. Connector Composites (C8, C9, C10), Vol 5	WP 0790
Figure 50. Connector Composites (C11), Vol 5	WP 0790
Figure 51. Connector Composites (J2, J5, J10, J19, J22, J33, J33, J33, J34), Vol 5	WP 0790
Figure 52. Connector Composites (J34, J34, J34, J36, P1, P3, P4, P4, P5), Vol 5	WP 0790
Figure 53. Connector Composites (P6, P8, P10, P12, P14, P17, P19), Vol 5	WP 0790
Figure 54. Connector Composites (P20, P21, P22, P23), Vol 5	WP 0790
Figure 55. Connector Composites (P29, P31, P33, P33, P33, P34), Vol 5	WP 0790
Figure 56. Connector Composites (P34, P34, P34, P35, P36, P37), Vol 5	WP 0790
Figure 57. Connector Composites (LAM1001, LAM1002, LAM1003, LAM1004, LAM1005, LAM1006, LAM1007), Vol 5	WP 0790
Figure 58. Connector Composites (LAM1008, LAM1009, LAM1010, LAM1011, LAM1012, LAM1013, LAM1014, LAM1015, LAM1016), Vol 5	WP 0790
Figure 59. Connector Composites (LAM1018, LAM1019, LAM1020, LAM1021, LAM1022, LAM1023, LAM1024, LAM1025), Vol 5	WP 0790
Figure 60. Connector Composites (LAM1026, LAM1027, LAM1028, LAM1029, LAM1030, LAM1031, LAM1032, LAM1033, LAM1034, LAM1035), Vol 5	WP 0790
Figure 61. Connector Composites (LAM1036, LAM1037, LAM1038, LAM1039, LAM1040, LAM1041, LAM1042, LAM1043, LAM1044, LAM1045), Vol 5	WP 0790
Figure 62. Connector Composites (LAM1046, LAM1047, LAM1048, LAM1049, LAM1050, LAM1051, LAM1052, LAM1053, LAM1054, LAM1055), Vol 5	WP 0790
Figure 63. Connector Composites (LAM1056, LAM1057, LAM1058, LAM1059, LAM1060, LAM1061, LAM1062, LAM1063, LAM1064, LAM1065), Vol 5	WP 0790
Figure 64. Connector Composites (LAM1066, LAM1068, LAM1069, LAM1070, LAM1071, LAM1072, LAM1073, LAM1074, LAM1075), Vol 5	WP 0790
Figure 65. Connector Composites (LAM1076, LAM1077, LAM1078, LAM1079, LAM1080, LAM1081, LAM1082, LAM1083, LAM1084, LAM1085), Vol 5	WP 0790
Figure 66. Connector Composites (LAM1086, LAM1087, LAM1088, LAM1089, LAM1090, LAM1091, LAM1092, LAM1093, LAM1094, LAM1095), Vol 5	WP 0790
Figure 67. Connector Composites (LAM1096, LAM1097, LAM1098, LAM1099, LAM1100, LAM1101, LAM1102, LAM1103, LAM1104, LAM1105), Vol 5	WP 0790
Figure 68. Connector Composites (LAM1106, LAM1107, LAM1108, LAM1109, LAM1110, LAM1111, LAM1112, LAM1113, LAM1114, LAM1115), Vol 5	WP 0790
Figure 69. Connector Composites (LAM1116, LAM1117, LAM1118, LAM1119, LAM1120, LAM1121, LAM1122, LAM1123, LAM1124, LAM1125), Vol 5	WP 0790
Figure 70. Connector Composites (LAM1126, LAM1127, LAM1128, LAM1129, LAM1130, LAM1131, LAM1132, LAM1133, LAM1134, LAM1135), Vol 5	WP 0790
Figure 71. Connector Composites (LAM1136, LAM1137, LAM1138, LAM1139, LAM1140, LAM1141, LAM1142, LAM1143, LAM1144, LAM1145), Vol 5	WP 0790
Figure 72. Connector Composites (LAM1146, LAM1147, LAM1148, LAM1149, LAM1150, LAM1151, LAM1152, LAM1153, LAM1154, LAM1155), Vol 5	WP 0790
Figure 73. Connector Composites (LAM1156, LAM1157, LAM1158, LAM1159, LAM1160, LAM1161, LAM1162, LAM1163, LAM1164, LAM1165), Vol 5	WP 0790

TABLE OF CONTENTS – (Continued)

	Page No.
	WP Sequence No.
Figure 74. Connector Composites (LAM1166, LAM1167, LAM1168, LAM1169, LAM1170, LAM1171, LAM1172, LAM1173, LAM1174, LAM1175), Vol 5	WP 0790
Figure 75. Connector Composites (LAM1176, LAM1177, LAM1178, LAM1179, LAM1180, LAM1181, LAM1182, LAM1183, LAM1184, LAM1185), Vol 5	WP 0790
Figure 76. Connector Composites (LAM1186, LAM1187, LAM1188, LAM1189, LAM1190, LAM1191, LAM1192, LAM1193, LAM1194, LAM1195), Vol 5	WP 0790
Figure 77. Connector Composites (LAM1196, LAM1197, LAM1198, LAM1199, LAM1200, LAM1201, LAM1202, LAM1203), Vol 5	WP 0790
Figure 78. Connector Composites (LAM1204, LAM1205, LAM1206, LAM1207, LAM1208, LAM1209), Vol 5	WP 0790
Figure 79. Connector Composites (LAM1210, LAM1211, LAM1212, LAM1213, LAM1214, LAM1215, LAM1216, LAM1217), Vol 5	WP 0790
CHAPTER 10. SUPPORTING INFORMATION, VOL 5	
REFERENCES, Vol 5	WP 0791
MAINTENANCE ALLOCATION CHART (MAC) INTRODUCTION, Vol 5	WP 0792
MAINTENANCE ALLOCATION CHART, Vol 5	WP 0793
EXPENDABLE AND DURABLE ITEMS LIST, Vol 5	WP 0794
TOOL IDENTIFICATION LIST, Vol 5	WP 0795
Mandatory Replacement Parts, Vol 5	WP 0796
	0608

CHAPTER 9
MAINTENANCE INSTRUCTIONS
FOR
MINE RESISTANT AMBUSH PROTECTED (MRAP)

FIELD MAINTENANCE
DOOR ARMOR PANEL REMOVAL AND INSTALLATION

INITIAL SETUP:**Tools and Special Tools**

General Mechanic's Tool Kit (GMTK)
(WP 0795, Item 37)
Lifting device (WP 0795, Item 67)
Lifting slings, (2) (WP 0795, Item 68)

TM 9-2355-106-23P

WP 0786

WP 0782

Materials/Parts

Gloves (WP 0794, Item 18)
Grease (WP 0794, Item 22)
Locknut - (9) (WP 0796, Item 148)

Equipment Condition

Parking brake set (TM 9-2355-106-10)
Transmission set in NEUTRAL (N) (TM
9-2355-106-10)
Engine off (TM 9-2355-106-10)
MAIN POWER switch off (TM 9-2355-106-10)
Wheels chocked (TM 9-2355-106-10)
Cabin door trim panel removed (WP 0626)
Door mounted mirror removed (WP 0682)

Personnel Required

Maintainer - (2)

References

TM 9-2355-106-10

WARNING

Armor parts are heavy. Use care when removing or installing. Do not attempt to lift without an assistant and lifting device. Failure to comply may result in serious injury or death to personnel.

NOTE

This procedure is the same for right and left side door armor panels. Left side procedure shown.

DOOR ARMOR PANEL REMOVAL AND INSTALLATION - (CONTINUED)**REMOVAL**

1. Remove three pine tree fasteners (Figure 1, Item 1) from door handle trim (Figure 1, Item 2). Remove trim.

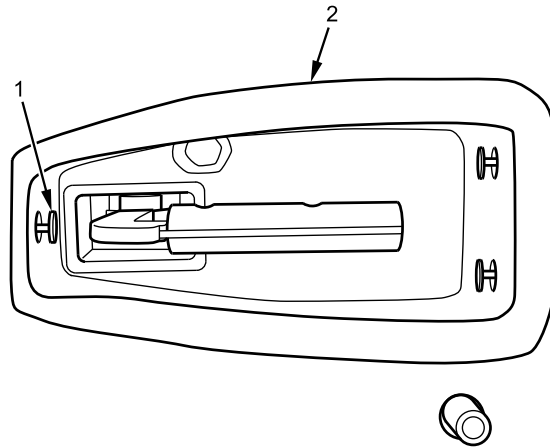

B231801647

Figure 1. Door Handle Trim.

2. Disconnect power mirror harness connector (Figure 2, Item 2) located under driver side kick panel (Figure 2, Item 1).

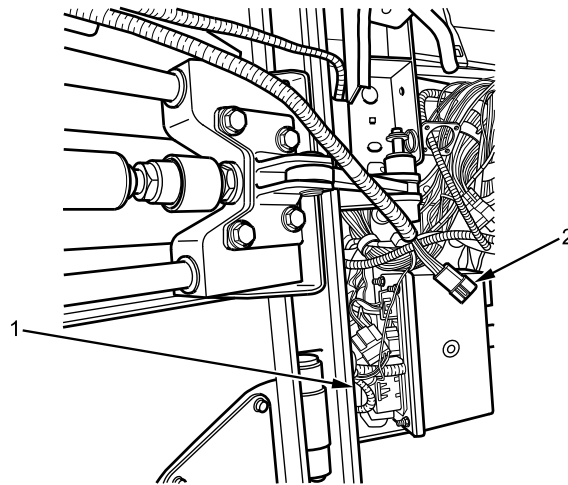

B231801652

Figure 2. Kick Panel Power Mirror Harness Connector.

DOOR ARMOR PANEL REMOVAL AND INSTALLATION - (CONTINUED)

3. Remove terminal retaining clip (Figure 3, Item 2) from harness connector (Figure 3, Item 1).

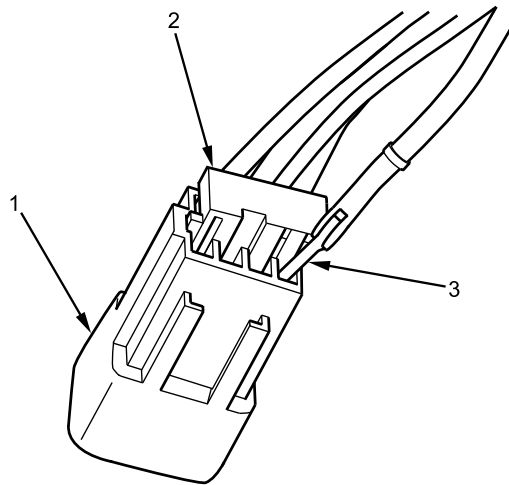

B231801649

Figure 3. Power Mirror Harness Connector.

NOTE

Mark and tag all wires properly for installation.

4. Remove five wires from harness connector (Figure 3, Item 1) by releasing terminals (Figure 3, Item 3) from connector.

NOTE

Use two slings to properly balance armor plate.

5. Secure lifting slings to window guard and attach slings to lifting device.

DOOR ARMOR PANEL REMOVAL AND INSTALLATION - (CONTINUED)**NOTE**

Carefully route power mirror harness through door while armor plate is being removed.

6. With assistant, remove eight bolts and washers (Figure 4, Item 3) from door armor panel (Figure 4, Item 2), and slowly remove door armor panel with power mirror harness from door (Figure 4, Item 1).

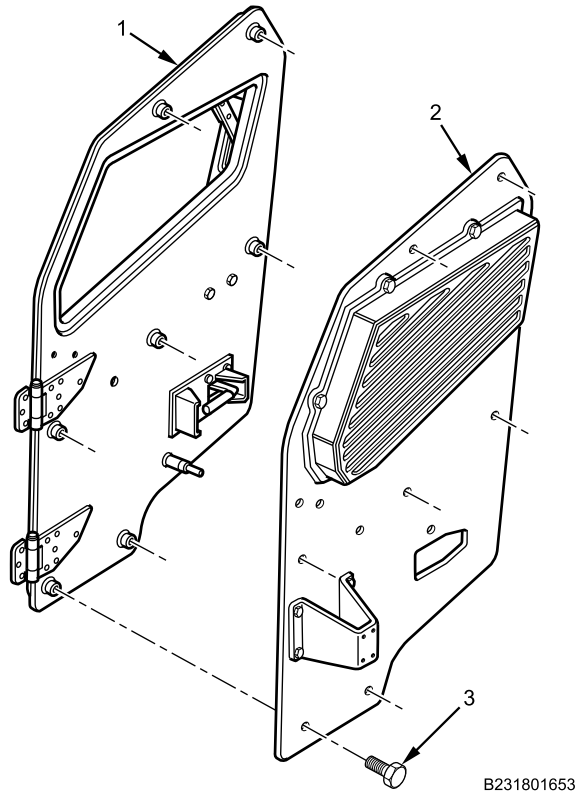
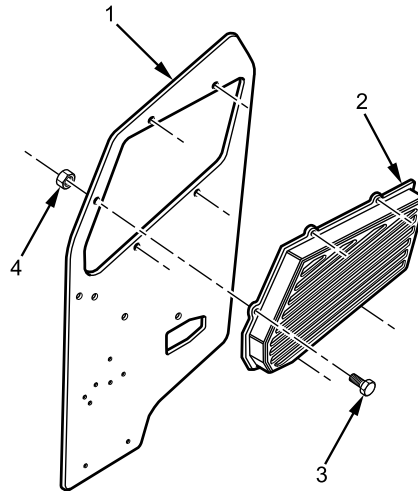

Figure 4. Door Armor.

END OF TASK

DOOR ARMOR PANEL REMOVAL AND INSTALLATION - (CONTINUED)**DISASSEMBLY**

1. Remove five bolts (Figure 5, Item 3), locknuts, and washers (Figure 5, Item 4) from window riot guard (Figure 5, Item 2) on armor door (Figure 5, Item 1). Remove guard and discard locknuts.



B231801602

Figure 5. Door Window Riot Guard.

2. Remove four bolts (Figure 6, Item 3), locknuts, and washers (Figure 6, Item 1) from mirror mounting plate (Figure 6, Item 2). Remove mounting plate and power mirror harness. Discard locknuts.

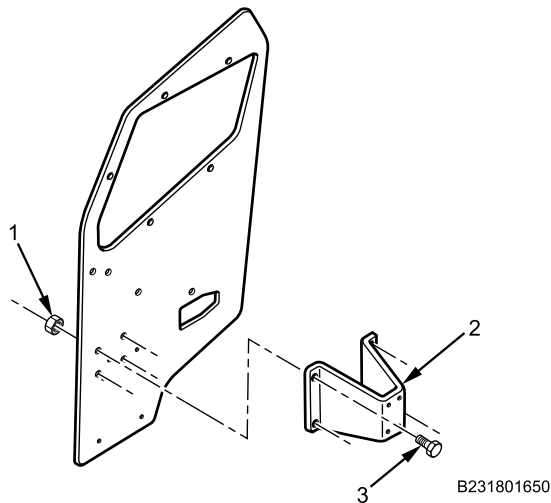

B231801650

Figure 6. Mirror Mounting Plate.

DOOR ARMOR PANEL REMOVAL AND INSTALLATION - (CONTINUED)

3. Remove power mirror harness (Figure 7, Item 1) by pulling through mirror mounting plate (Figure 7, Item 2) and armor door.

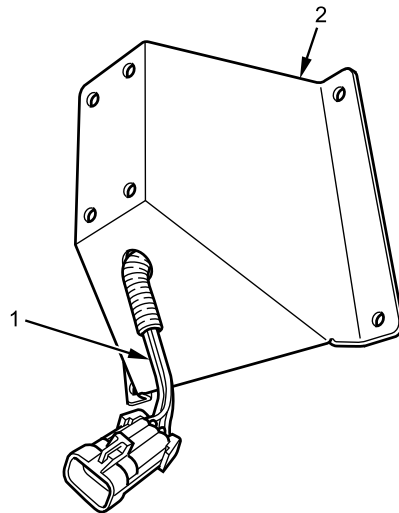

B231801689

Figure 7. Mirror Harness.

END OF TASK**ASSEMBLY**

1. Install window riot guard (Figure 8, Item 2) on armor door (Figure 8, Item 1) with five bolts (Figure 8, Item 3), washers, and new locknuts (Figure 8, Item 4).

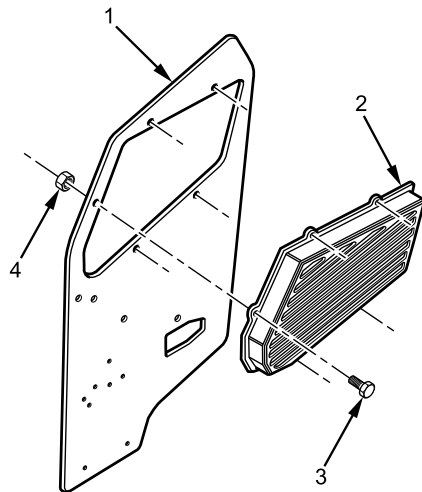

B231801602

Figure 8. Door Window Riot Guard.

DOOR ARMOR PANEL REMOVAL AND INSTALLATION - (CONTINUED)

2. Install power mirror harness (Figure 9, Item 1) through mirror mounting plate (Figure 9, Item 2) and armor door.

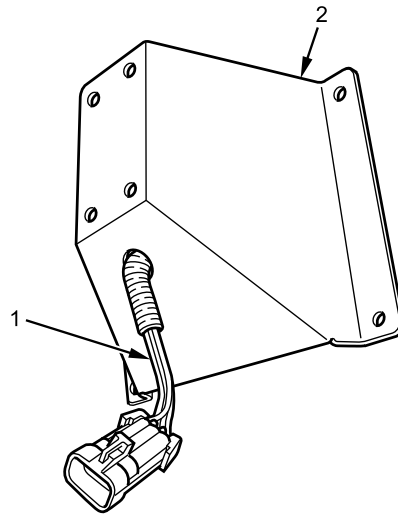

B231801689

Figure 9. Mirror Harness.

3. Install mirror mounting plate (Figure 10, Item 2) with four bolts (Figure 10, Item 3), washers, and new locknuts (Figure 10, Item 1). Tighten bolts securely.

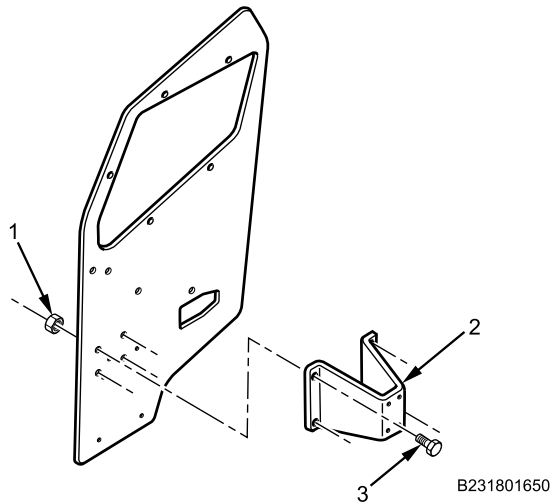

B231801650

Figure 10. Mirror Mounting Plate.

END OF TASK

DOOR ARMOR PANEL REMOVAL AND INSTALLATION - (CONTINUED)**INSTALLATION****NOTE**

Carefully route power mirror harness through location hole on door while armor panel is being installed.

1. With assistant, slowly install door armor panel (Figure 11, Item 2) on door (Figure 11, Item 1) with eight bolts and washers (Figure 11, Item 3) while routing power mirror harness through door. Tighten bolts securely.

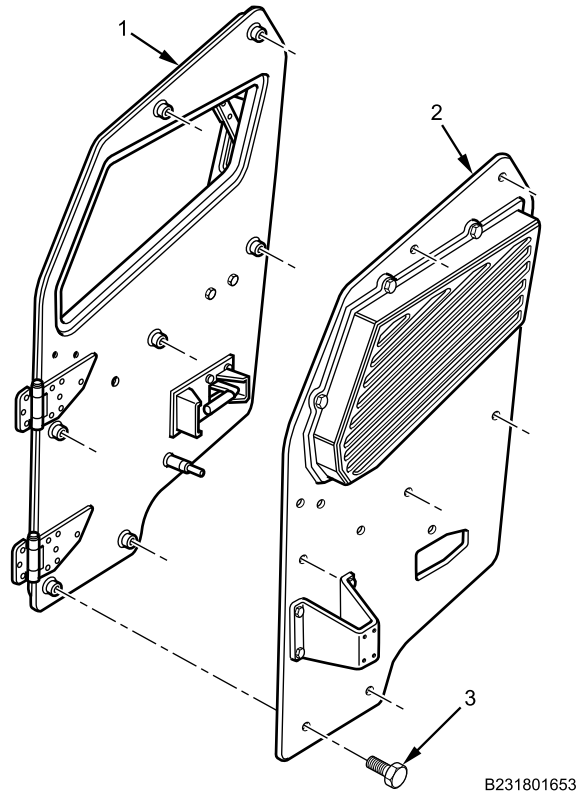
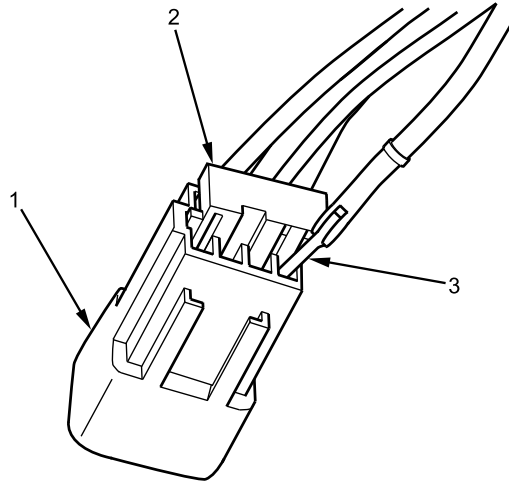

Figure 11. Door Armor.

DOOR ARMOR PANEL REMOVAL AND INSTALLATION - (CONTINUED)

2. Install five terminals (Figure 12, Item 3) in correct location on power mirror harness connector (Figure 12, Item 1).



B231801649

Figure 12. Power Mirror Harness Connector.

3. Install terminal retaining clip (Figure 12, Item 2) in connector (Figure 12, Item 1).

WARNING

Dielectric grease is harmful to skin and eyes. If grease contacts eyes, rinse thoroughly and contact physician if irritation persists. If skin is contacted, wash thoroughly with soap and water. Failure to comply may result in serious injury to personnel.

4. Apply dielectric grease in wiring harness connectors.

DOOR ARMOR PANEL REMOVAL AND INSTALLATION - (CONTINUED)

5. Connect power mirror harness connector (Figure 13, Item 2) to harness under driver side kick panel (Figure 13, Item 1).

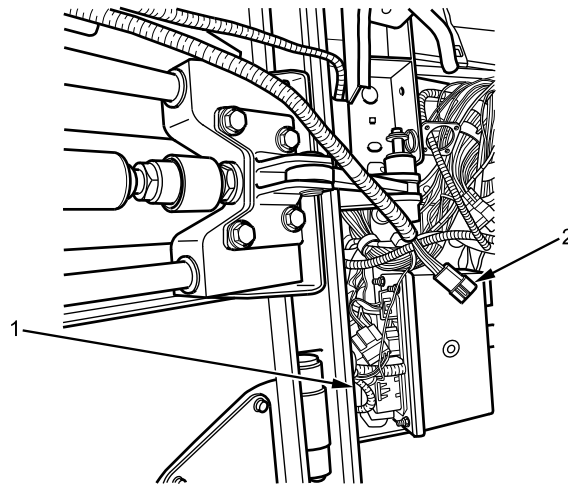

B231801652

Figure 13. Kick Panel Power Mirror Harness Connector.

6. Install door handle trim (Figure 14, Item 2) on door armor with three pine tree fasteners (Figure 14, Item 1).

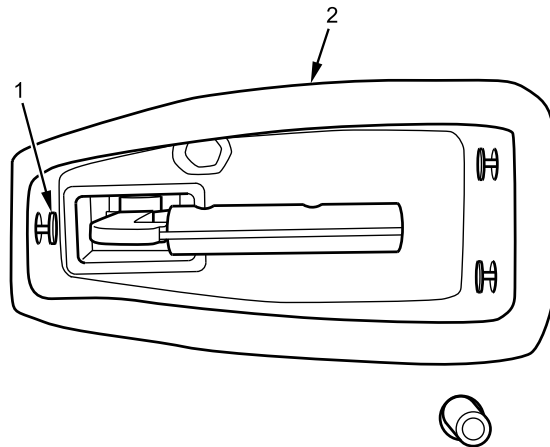

B231801647

Figure 14. Door Handle Trim.

END OF TASK

DOOR ARMOR PANEL REMOVAL AND INSTALLATION - (CONTINUED)**FOLLOW-ON MAINTENANCE**

1. Install cabin door trim panel (WP 0626).
2. Install door mounted mirror (WP 0682).
3. Remove wheel chocks (TM 9-2355-106-10).

END OF TASK**END OF WORK PACKAGE**

FIELD MAINTENANCE**DOOR WINDOW RIOT GUARD REMOVAL AND INSTALLATION**

INITIAL SETUP:**Tools and Special Tools**

General Mechanic's Tool Kit (GMTK)
(WP 0795, Item 37)

WP 0782

Equipment Condition

Parking brake set (TM 9-2355-106-10)
Transmission set in NEUTRAL (N) (TM
9-2355-106-10)
Engine off (TM 9-2355-106-10)
MAIN POWER switch off (TM 9-2355-106-10)
Wheels chocked (TM 9-2355-106-10)
Door armor panel removed (WP 0609)

Personnel Required

Maintainer - (2)

References

TM 9-2355-106-10
TM 9-2355-106-23P
WP 0786

WARNING

Armor parts are heavy. Use care when removing or installing. Do not attempt to lift without an assistant and lifting device. Wear gloves. Failure to comply may result in serious injury or death to personnel.

NOTE

This procedure is the same for right and left door window riot guards. Left side procedure shown.

DOOR WINDOW RIOT GUARD REMOVAL AND INSTALLATION - (CONTINUED)**REMOVAL**

1. With assistant, remove five bolts (Figure 1, Item 3) and nuts (Figure 1, Item 4) from window riot guard (Figure 1, Item 2) on armor door (Figure 1, Item 1). Remove guard.

END OF TASK**INSTALLATION**

1. With assistant, install window riot guard (Figure 1, Item 2) on door armor (Figure 1, Item 1) with five bolts (Figure 1, Item 3) and nuts (Figure 1, Item 4). Tighten bolts securely.

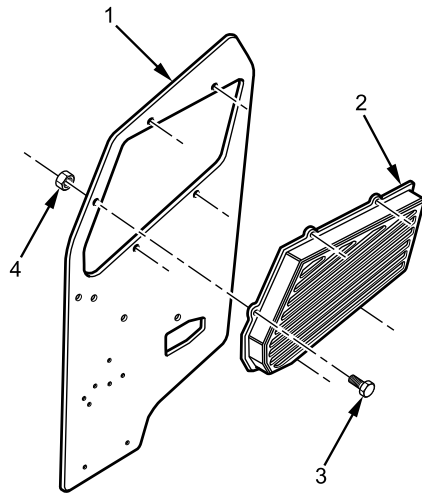

B231801602

Figure 1. Door Window Riot Guard.

END OF TASK**FOLLOW-ON MAINTENANCE**

1. Install door armor panel (WP 0609).
2. Remove wheel chocks (TM 9-2355-106-10).

END OF TASK**END OF WORK PACKAGE**

FIELD MAINTENANCE**UPPER CABIN DOOR LOCK, SPACER, AND BRACKET REMOVAL AND INSTALLATION**

INITIAL SETUP:**Tools and Special Tools**

General Mechanic's Tool Kit (GMTK)
(WP 0795, Item 37)

References

TM 9-2355-106-10
TM 9-2355-106-23P
WP 0782

Transmission set in NEUTRAL (N) (TM
9-2355-106-10)

Engine off (TM 9-2355-106-10)

MAIN POWER switch off (TM 9-2355-106-10)

Wheels chocked (TM 9-2355-106-10)

Cabin door secured in open position (WP 0608)

Cabin door trim panel removed (WP 0626)

Equipment Condition

Parking brake set (TM 9-2355-106-10)

WARNING

Cabin door must be secured in the open position by using heavy duty winch straps to prevent accidental closure during vehicle maintenance. Pull check link retaining pin prior to securing door open. Failure to comply may result in serious injury or death to personnel.

Use the appropriate lifting strap sling or chain hoist for the type of load. Always clean and inspect lifting strap slings and chain hoists prior to use. Inspect for damage such as wear, corrosion, elongation, tears, or punctures. Replace lifting strap slings or chain hoists that are damaged. Failure to comply may result in component damage and death or injury to personnel.

UPPER CABIN DOOR LOCK, SPACER, AND BRACKET REMOVAL AND INSTALLATION - (CONTINUED)

REMOVAL

NOTE

Right and left door procedures are identical. Left door shown.

1. Remove retainer clip (Figure 1, Item 8) by rotating counterclockwise off of rod (Figure 1, Item 9) and pulling retainer clip out of lever (Figure 1, Item 11).

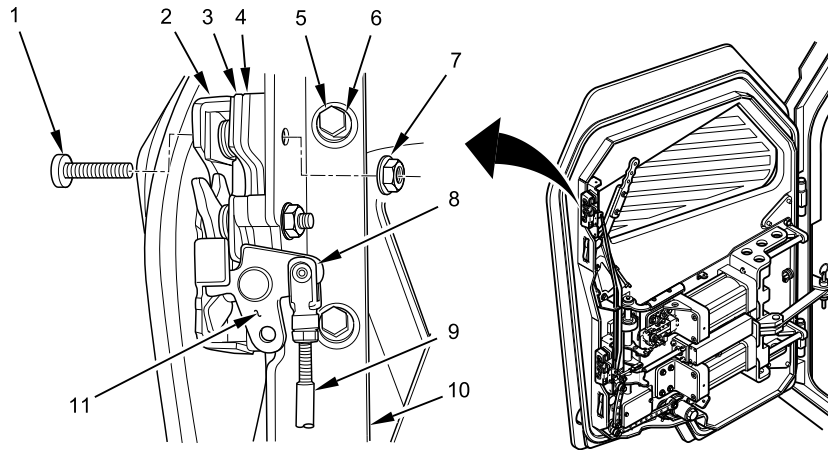

B231805651

Figure 1. Upper Cabin Door Lock, Spacer, and Bracket Removal.

2. Remove three screws (Figure 1, Item 1), nuts (Figure 1, Item 7), two spacers (Figure 1, Item 3 and 4), and cabin door lock (Figure 1, Item 2) from bracket (Figure 1, Item 10).
3. Remove two screws (Figure 1, Item 5), flat washers (Figure 1, Item 6) and bracket (Figure 1, Item 10) from door.

END OF TASK

UPPER CABIN DOOR LOCK, SPACER, AND BRACKET REMOVAL AND INSTALLATION - (CONTINUED)**INSTALLATION**

1. Install bracket (Figure 2, Item 10) on door with two flat washers (Figure 2, Item 6) and screws (Figure 2, Item 5).

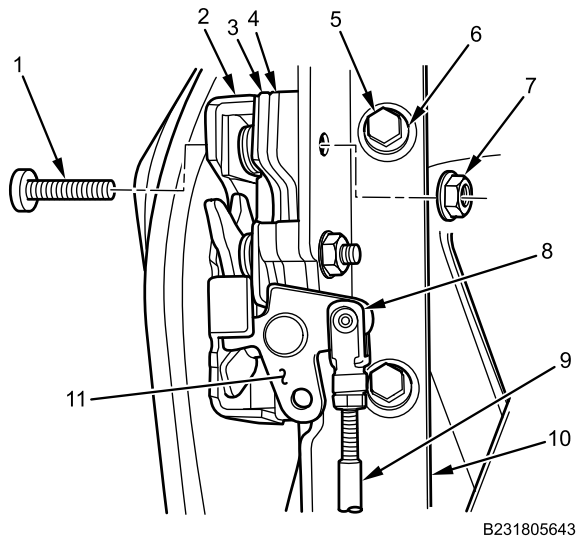

Figure 2. Upper Cabin Door Lock, Spacer, and Bracket Installation.

2. Install cabin door lock (Figure 2, Item 2) and two spacers (Figure 2, Item 3 and 4) on bracket (Figure 2, Item 10) with three screws (Figure 2, Item 1) and nuts (Figure 2, Item 7).
3. Position rod (Figure 2, Item 9) on lever (Figure 2, Item 11) and secure with clip (Figure 2, Item 8) by pushing clip through rod and lever and rotating clip clockwise.

END OF TASK**FOLLOW-ON MAINTENANCE**

1. Install cabin door trim panel (WP 0626).
2. Remove cabin door securing chain hoists and lifting strap (WP 0608).
3. Remove wheel chocks (TM 9-2355-106-10).

END OF TASK**END OF WORK PACKAGE**

FIELD MAINTENANCE**LOWER CABIN DOOR LOCK, SPACER, AND BRACKET REMOVAL AND INSTALLATION**

INITIAL SETUP:**Tools and Special Tools**

General Mechanic's Tool Kit (GMTK)
(WP 0795, Item 37)

References

TM 9-2355-106-10
TM 9-2355-106-23P
WP 0782

Transmission set in NEUTRAL (N) (TM
9-2355-106-10)

Engine off (TM 9-2355-106-10)

MAIN POWER switch off (TM 9-2355-106-10)

Wheels chocked (TM 9-2355-106-10)

Cabin door secured in open position (WP 0608)

Cabin door trim panel removed (WP 0626)

Equipment Condition

Parking brake set (TM 9-2355-106-10)

WARNING

Cabin door must be secured in the open position by using heavy duty winch straps to prevent accidental closure during vehicle maintenance. Pull door hinge pin prior to securing door open. Failure to comply may result in serious injury or death to personnel.

Use the appropriate lifting strap sling or chain hoist for the type of load. Always clean and inspect lifting strap slings and chain hoists prior to use. Inspect for damage such as wear, corrosion, elongation, tears, or punctures. Replace lifting strap slings or chain hoists that are damaged. Failure to comply may result in component damage and death or injury to personnel.

LOWER CABIN DOOR LOCK, SPACER, AND BRACKET REMOVAL AND INSTALLATION - (CONTINUED)**REMOVAL****NOTE**

Right and left door procedures are identical. Left door shown.

1. Remove retainer clip (Figure 1, Item 2) by rotating clockwise off of rod (Figure 1, Item 1) and pulling retainer clip out of lever (Figure 1, Item 5).
2. Remove retainer clip (Figure 1, Item 4) by rotating clockwise off of rod (Figure 1, Item 3) and pulling retainer clip out of lever (Figure 1, Item 5).

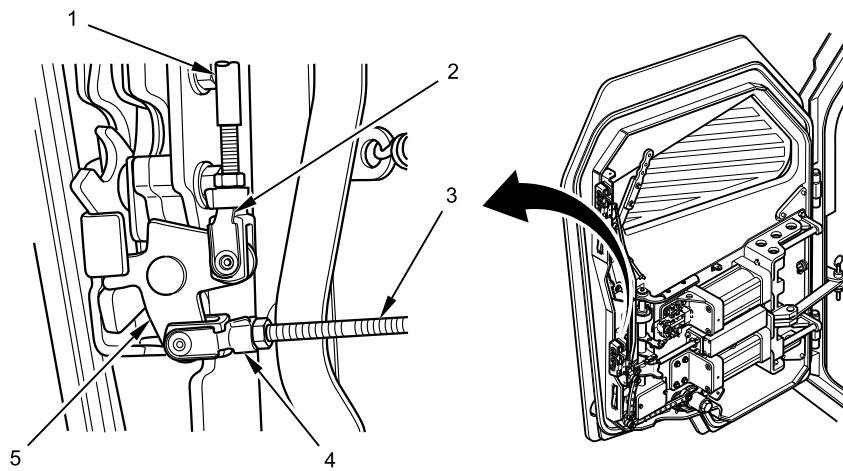

B231805664

Figure 1. Lower Cabin Door Lock Retainer Clip Removal.

3. Remove three screws (Figure 2, Item 1), nuts (Figure 2, Item 6), two spacers (Figure 2, Item 7 and 8), and cab door lock (Figure 2, Item 2) from bracket (Figure 2, Item 3).
4. Remove two screws (Figure 2, Item 5), flat washers (Figure 2, Item 4) and bracket (Figure 2, Item 3) from door.

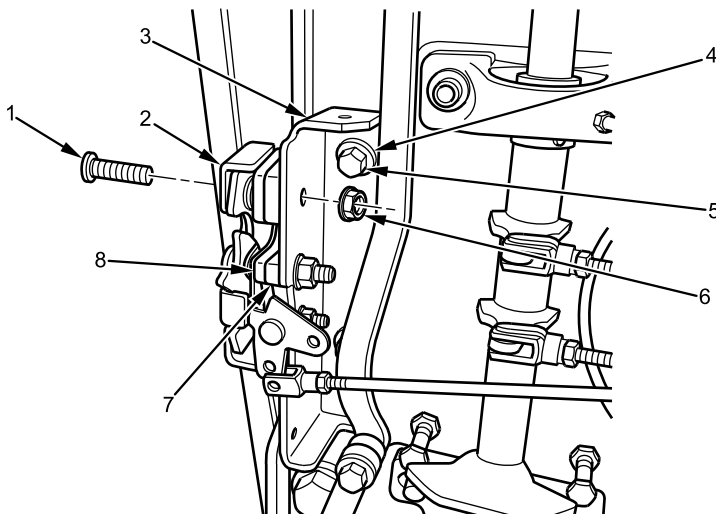

B231805665

Figure 2. Lower Cabin Door Lock, Spacer, and Bracket Removal.

END OF TASK

LOWER CABIN DOOR LOCK, SPACER, AND BRACKET REMOVAL AND INSTALLATION - (CONTINUED)**INSTALLATION**

1. Install bracket (Figure 3, Item 3) on door with two flat washers (Figure 3, Item 4) and screws (Figure 3, Item 5).

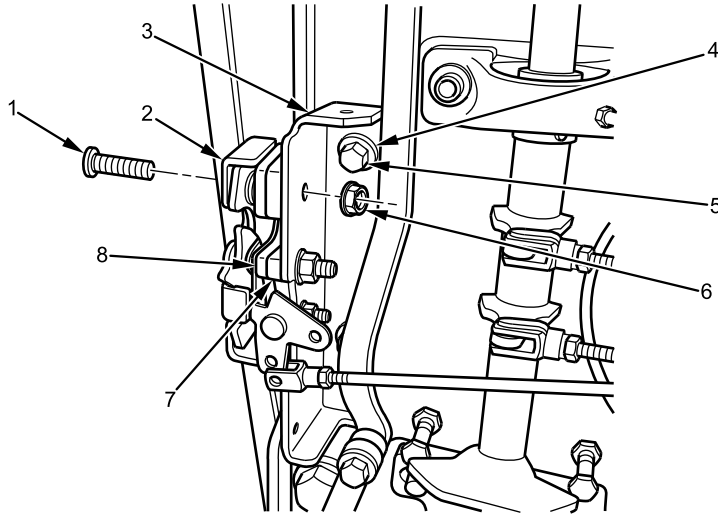

B231805665

Figure 3. Lower Cabin Door Lock, Spacer, and Bracket Installation.

2. Install cab door lock (Figure 3, Item 2) and two spacers (Figure 3, Item 7 and 8) on bracket (Figure 3, Item 3) with three screws (Figure 3, Item 1) and nuts (Figure 3, Item 6).
3. Position rod (Figure 4, Item 3) on lever (Figure 4, Item 5) and secure with clip (Figure 4, Item 4) by pushing clip through rod and lever and rotating clip counterclockwise.
4. Position rod (Figure 4, Item 1) on lever (Figure 4, Item 5) and secure with clip (Figure 4, Item 2) by pushing clip through rod and lever and rotating clip counterclockwise.

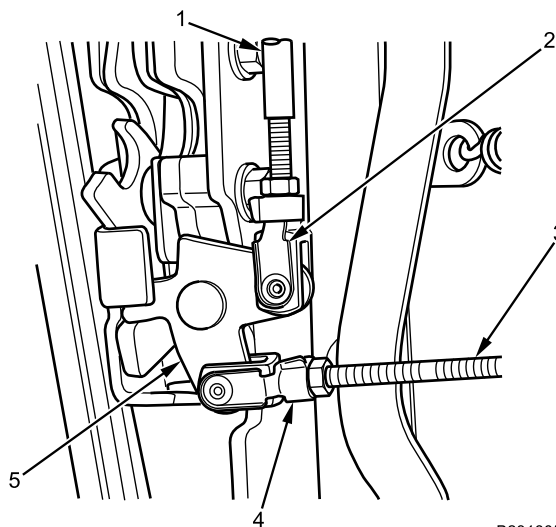

B231805663

Figure 4. Lower Cabin Door Lock Retainer Clip Installation.

END OF TASK

LOWER CABIN DOOR LOCK, SPACER, AND BRACKET REMOVAL AND INSTALLATION - (CONTINUED)**FOLLOW-ON MAINTENANCE**

1. Install cabin door trim panel (WP 0626).
2. Remove cabin door securing chain hoists and lifting strap (WP 0608).
3. Remove wheel chocks (TM 9-2355-106-10).

END OF TASK**END OF WORK PACKAGE**

FIELD MAINTENANCE**CABIN DOOR STRIKER AND CABIN DOOR CHECK STOP ASSEMBLIES REMOVAL AND INSTALLATION**

INITIAL SETUP:**Tools and Special Tools**

General Mechanic's Tool Kit (GMTK)
(WP 0795, Item 37)
Attachment, screwdriver, Torx bit, 3/8-inch drive, T50
(WP 0795, Item 11)

References

TM 9-2355-106-10
TM 9-2355-106-23P
WP 0782

Equipment Condition

Parking brake set (TM 9-2355-106-10)
Transmission set in NEUTRAL (N) (TM
9-2355-106-10)
Engine off (TM 9-2355-106-10)
MAIN POWER switch off (TM 9-2355-106-10)
Wheels chocked (TM 9-2355-106-10)
Cabin door secured in open position (WP 0608)

WARNING

Cabin door must be secured in the open position by using heavy duty winch straps to prevent accidental closure during vehicle maintenance. Pull door hinge pin prior to securing door open. Failure to comply may result in serious injury or death to personnel.

Use the appropriate lifting strap sling or chain hoist for the type of load. Always clean and inspect lifting strap slings and chain hoists prior to use. Inspect for damage such as wear, corrosion, elongation, tears, or punctures. Replace lifting strap slings or chain hoists that are damaged. Failure to comply may result in component damage and death or injury to personnel.

**CABIN DOOR STRIKER AND CABIN DOOR CHECK STOP ASSEMBLIES REMOVAL AND INSTALLATION -
(CONTINUED)****REMOVAL****NOTE**

Right and left door procedures are identical. Left door shown.

Each door uses two door strikers. Replacement procedure is identical for either striker.

1. Remove two retainers (Figure 1, Item 2) and door striker tapping plate cover (Figure 1, Item 1) from door frame (Figure 1, Item 3).

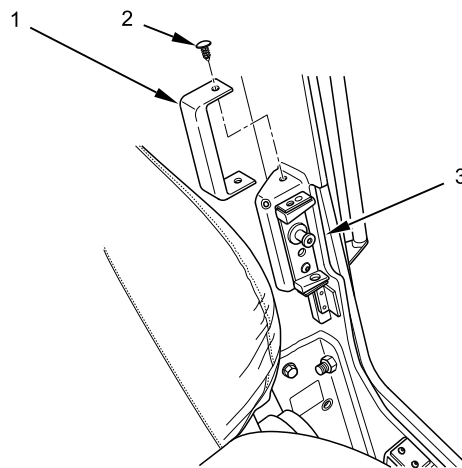

B231804915

Figure 1. Cabin Door Striker Tapping Plate Cover Removal.

**CABIN DOOR STRIKER AND CABIN DOOR CHECK STOP ASSEMBLIES REMOVAL AND INSTALLATION -
(CONTINUED)****NOTE**

Not all vehicles equipped with shim. Replace shim if removed from bracket.

2. Remove two screws (Figure 2, Item 5), striker (Figure 2, Item 6), bracket (Figure 2, Item 4), shim (if equipped) (Figure 2, Item 3), and tapping plate (Figure 2, Item 1) from B pillar (Figure 2, Item 2).

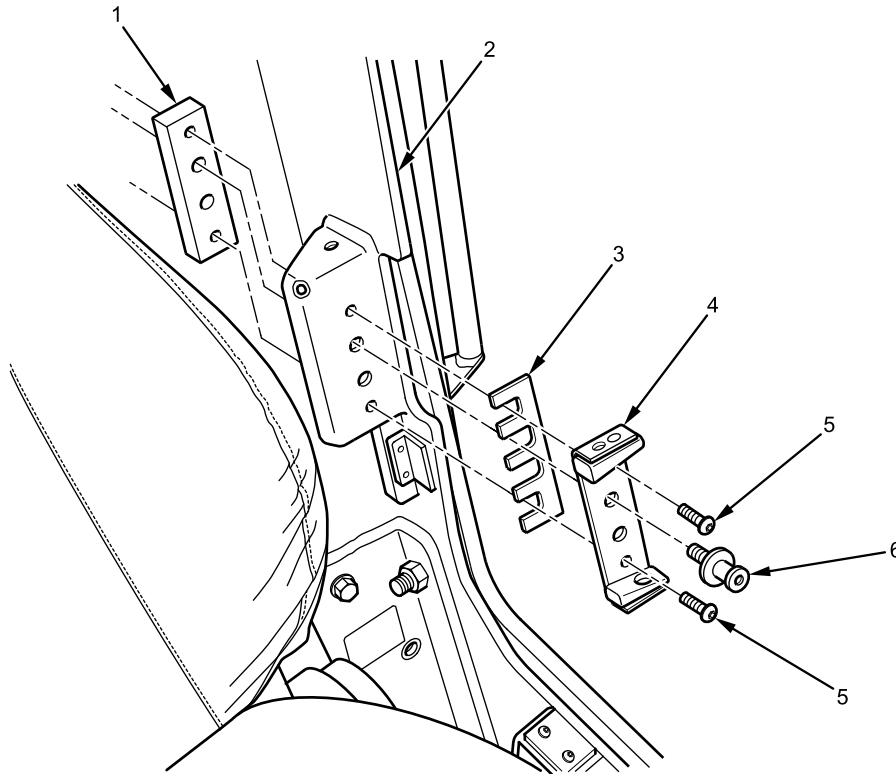

B231804916

Figure 2. Cabin Door Striker Removal.

CABIN DOOR STRIKER AND CABIN DOOR CHECK STOP ASSEMBLIES REMOVAL AND INSTALLATION - (CONTINUED)

NOTE

Each door has three combat lock door check stops. One is shown, other two are similar.

3. Remove two screws (Figure 3, Item 1), flat washers (Figure 3, Item 2), and combat lock door check stop (Figure 3, Item 3) from bracket (Figure 3, Item 4).

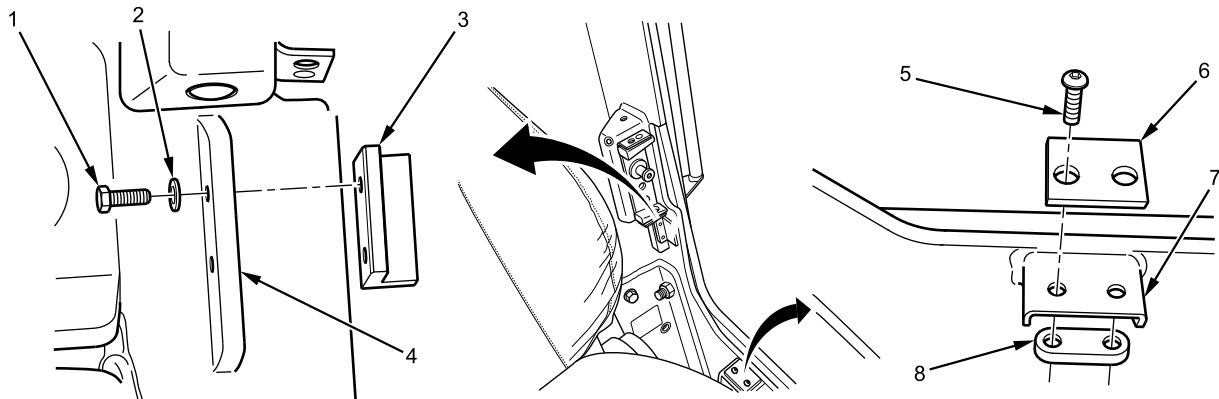

B231804917

Figure 3. Door Check Stop Removal.

4. Remove two screws (Figure 3, Item 5), door check stop (Figure 3, Item 6), and tapping plate (Figure 3, Item 8) from bracket (Figure 3, Item 7).

END OF TASK

INSTALLATION

1. Install door check stop (Figure 4, Item 6) and tapping plate (Figure 4, Item 8) on bracket (Figure 4, Item 7) with two screws (Figure 4, Item 5).

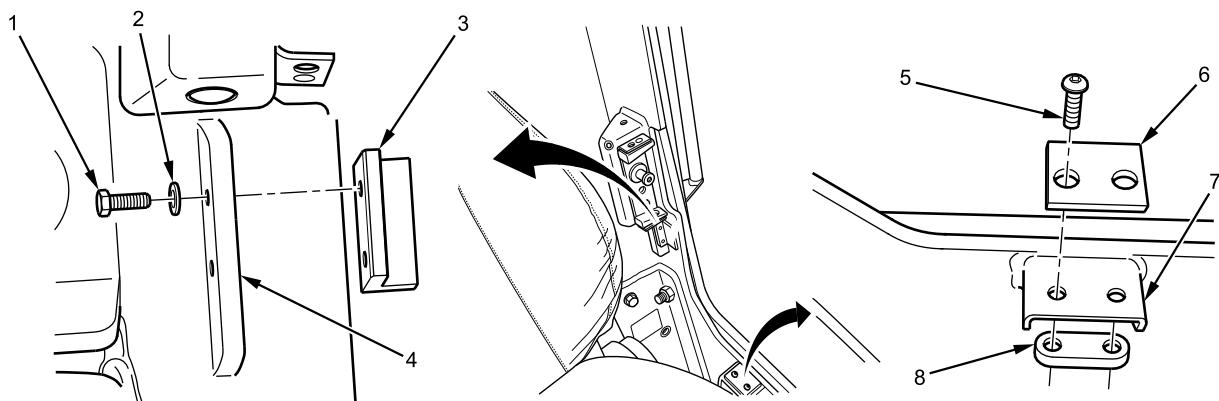

B231804917

Figure 4. Door Check Stop Installation.

2. Install combat lock door check stop (Figure 4, Item 3) on bracket (Figure 4, Item 4) with two flat washers (Figure 4, Item 2) and screws (Figure 4, Item 1).

CABIN DOOR STRIKER AND CABIN DOOR CHECK STOP ASSEMBLIES REMOVAL AND INSTALLATION - (CONTINUED)

3. Install shim (if equipped) (Figure 5, Item 3), bracket (Figure 5, Item 4), and tapping plate (Figure 5, Item 1), on B pillar (Figure 5, Item 2) with two screws (Figure 5, Item 5) and striker (Figure 5, Item 6).

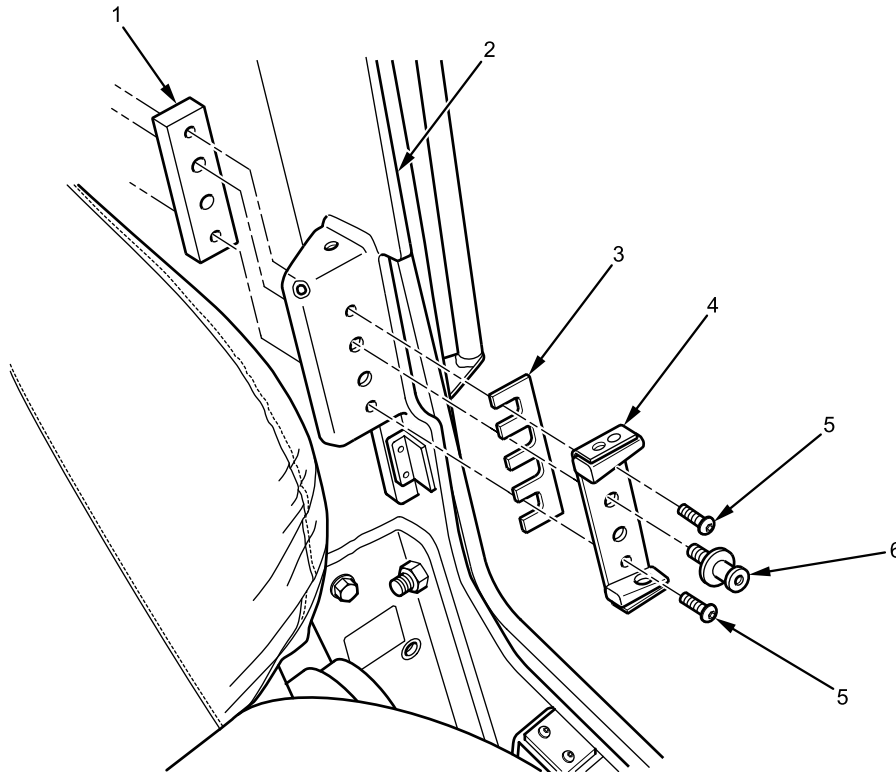

B231804916

Figure 5. Cabin Door Striker Installation.

CABIN DOOR STRIKER AND CABIN DOOR CHECK STOP ASSEMBLIES REMOVAL AND INSTALLATION - (CONTINUED)

4. Install door striker tapping plate cover (Figure 6, Item 1) on door frame (Figure 6, Item 3) with two push fasteners (Figure 6, Item 2).

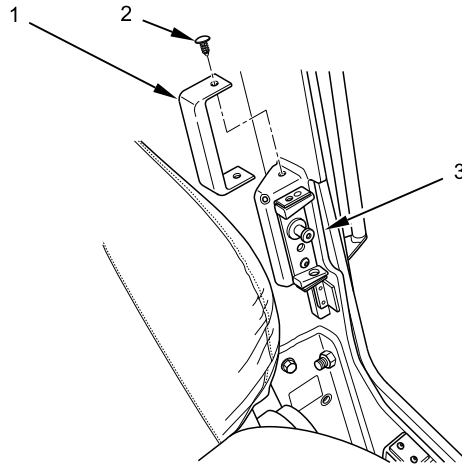

B231804915

Figure 6. Cabin Door Striker Tapping Plate Cover Installation.

END OF TASK**FOLLOW-ON MAINTENANCE**

1. Remove cabin door securing chain hoists and lifting strap (WP 0608).
2. Remove wheel chocks (TM 9-2355-106-10).

END OF TASK**END OF WORK PACKAGE**

FIELD MAINTENANCE
CABIN DOOR SEAL REMOVAL AND INSTALLATION

INITIAL SETUP:**Tools and Special Tools**

General Mechanic's Tool Kit (GMTK)
(WP 0795, Item 37)
Knife, utility, retractable (WP 0795, Item 65)

Materials/Parts

Goggles, industrial (WP 0794, Item 20)
Gloves (WP 0794, Item 18)
Rag (WP 0794, Item 39)
Adhesive, weatherstrip (WP 0794, Item 4)
Alcohol, isopropyl (WP 0794, Item 26)
Primer, adhesive (WP 0794, Item 38)
Brush, adhesive primer (WP 0794, Item 8)

References

TM 9-2355-106-10
TM 9-2355-106-23P
WP 0782

Equipment Condition

Parking brake set (TM 9-2355-106-10)
Transmission set in NEUTRAL (N) (TM 9-2355-106-10)
Engine off (TM 9-2355-106-10)
MAIN POWER switch off (TM 9-2355-106-10)
Wheels chocked (TM 9-2355-106-10)
Cabin door secured safely open (WP 0608)

WARNING

Cabin door must be secured in the open position by using heavy duty winch straps to prevent accidental closure during vehicle maintenance. Pull door hinge pin prior to securing door open. Failure to comply may result in serious injury or death to personnel.

Use the appropriate lifting strap sling or chain hoist for the type of load. Always clean and inspect lifting strap slings and chain hoists prior to use. Inspect for damage such as wear, corrosion, elongation, tears, or punctures. Replace lifting strap slings or chain hoists that are damaged. Failure to comply may result in component damage and death or injury to personnel.

NOTE

Right side shown; left side similar.

CABIN DOOR SEAL REMOVAL AND INSTALLATION - (CONTINUED)

REMOVAL

1. Remove the seal (Figure 1, Item 2) from the door (Figure 1, Item 1) using a putty scraper knife.

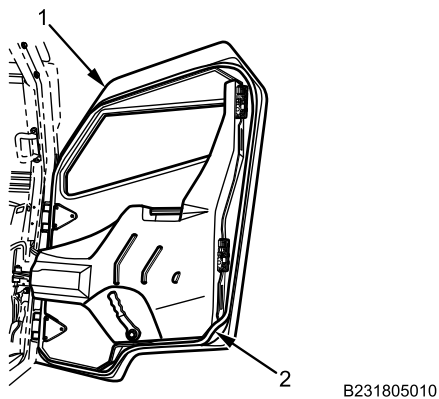

Figure 1. Cabin Door Seal Removal.

2. Remove any remaining adhesive from the door (Figure 1, Item 1) using a putty scraper knife.

END OF TASK

INSTALLATION

WARNING



Adhesives, solvents, and sealing compounds can burn easily, can give off harmful vapors, and are harmful to skin and clothing. Wear goggles and protective clothing. Keep away from open flame and use in well-ventilated area. If adhesive, solvent, or sealing compound get on skin or clothing, wash immediately with soap and water. Failure to comply may result in injury or death to personnel.

1. Clean the perimeter (Figure 2, Item 2) of the door (Figure 2, Item 1) with a 50/50 isopropyl alcohol and water mixture using a clean rag.

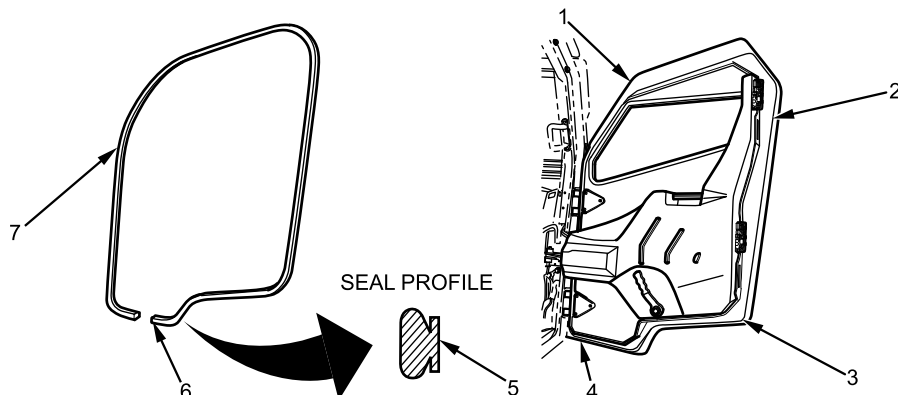

Figure 2. Cabin Door Seal Application.

CABIN DOOR SEAL REMOVAL AND INSTALLATION - (CONTINUED)

2. Apply a thin uniform coating of adhesive primer to the perimeter (Figure 2, Item 2) of the door (Figure 2, Item 1) with a brush where the new seal (Figure 2, Item 7) is to be placed. Allow 10 minutes for adhesive primer to dry.
3. Apply seal (Figure 2, Item 7) to the door (Figure 2, Item 1) by pulling tape from the seal exposing about 6 inches of adhesive surface (Figure 2, Item 5) at a time.
4. Position the seal (Figure 2, Item 7) at the perimeter (Figure 2, Item 2) starting with the lowest middle straight section (Figure 2, Item 4) of the door (Figure 2, Item 1).
5. Curve the seal (Figure 2, Item 7) in the corners (Figure 2, Item 3) as close as possible without excessively distorting or folding the seal.
6. Trim and discard excess seal (Figure 2, Item 7) with a utility knife to make a tight fitting seam (Figure 2, Item 6).
7. Apply weatherstrip adhesive to seam (Figure 2, Item 6) of seal (Figure 2, Item 7) and allow 15 minutes for adhesive to bond.

END OF TASK**FOLLOW-ON MAINTENANCE**

1. Remove cabin door securing chain hoists and lifting strap (WP 0608).
2. Remove wheel chocks (TM 9-2355-106-10).

END OF TASK**END OF WORK PACKAGE**

FIELD MAINTENANCE**CABIN DOOR LINKAGE INSPECTION AND ADJUSTMENT PROCEDURE (LOWER INTERIOR COMBAT DOOR LOCK-TYPE)**

INITIAL SETUP:**Tools and Special Tools**

General Mechanic's Tool Kit (GMTK)
(WP 0795, Item 37)
Grease gun (WP 0795, Item 41)

Materials/Parts

Grease (WP 0794, Item 21)

References

TM 9-2355-106-10
TM 9-2355-106-23P
WP 0782

Equipment Condition

Parking brake set (TM 9-2355-106-10)
Transmission set in NEUTRAL (N) (TM 9-2355-106-10)
Engine off (TM 9-2355-106-10)
MAIN POWER switch off (TM 9-2355-106-10)
Wheels chocked (TM 9-2355-106-10)
Air tanks and reservoirs drained (TM 9-2355-106-10)
Cabin door secured safely open (WP 0608)
Cabin door trim panel removed (WP 0626) or (WP 0627)

INSPECTION AND ADJUSTMENT**WARNING**

Cab door must be secured in the open position by using heavy duty winch straps to prevent accidental closure during vehicle maintenance. Pull door hinge pin prior to securing door open. Failure to comply may result in serious injury or death to personnel.

Use the appropriate lifting strap sling or chain hoist for the type of load. Always clean and inspect lifting strap slings and chain hoists prior to use. Inspect for damage such as wear, corrosion, elongation, tears, or punctures. Replace lifting strap slings or chain hoists that are damaged. Failure to comply may result in component damage and death or injury to personnel.

NOTE

Cabin door linkage removal and adjustment instructions should be discussed prior to starting the work package replacement task, to ensure instructions are understood by all participants. Mark and label all connections and reference areas before removal of component parts.

CABIN DOOR LINKAGE INSPECTION AND ADJUSTMENT PROCEDURE (LOWER INTERIOR COMBAT DOOR LOCK-TYPE) - (CONTINUED)

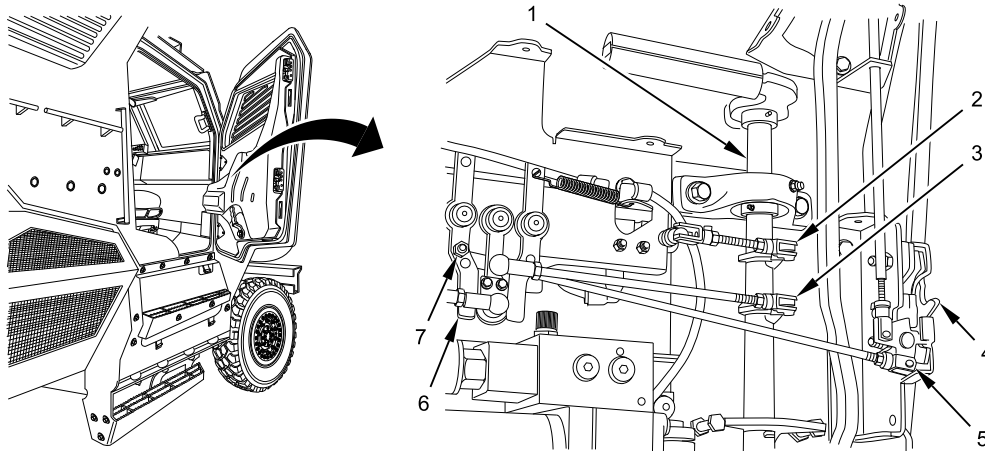

B231804977

Figure 1. Inner Door Latch Handle Shaft in Neutral Position.

NOTE

All door linkage travel adjustments are performed by removing any clevis retaining clip or nut securing linkage, loosening linkage jam nut, and rotating individual linkage end to obtain proper setting.

1. Ensure inner door latch handle shaft (Figure 1, Item 1) is not binding and is in neutral position.
2. Ensure air valve linkage shaft (Figure 1, Item 2) and door latch linkage shaft (Figure 1, Item 3) are properly attached and secured to inner door latch handle shaft (Figure 1, Item 1).
3. Ensure lower shaft linkage retaining clip (Figure 1, Item 5) is properly attached to lower door latch assembly (Figure 1, Item 4) and secured to main latch assembly module (Figure 1, Item 6) with locknut (Figure 1, Item 7).

CABIN DOOR LINKAGE INSPECTION AND ADJUSTMENT PROCEDURE (LOWER INTERIOR COMBAT DOOR LOCK-TYPE) - (CONTINUED)

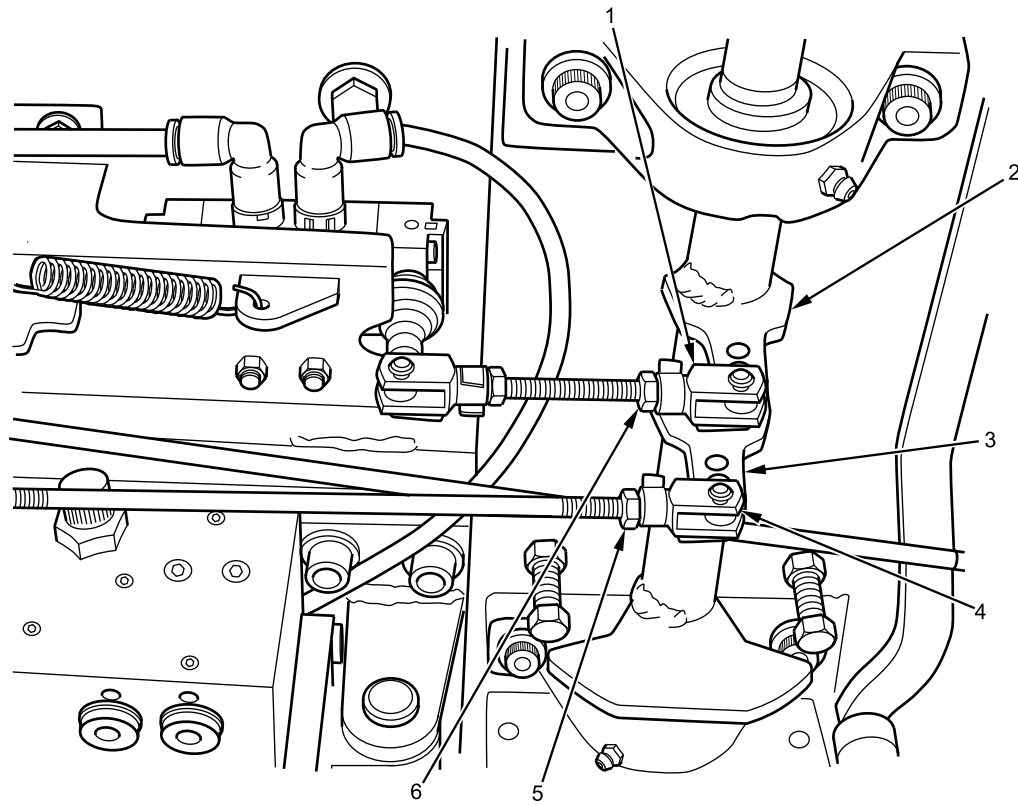

B231802216

Figure 2. Air Valve Linkage Centered on Latch Handle Shaft.

4. Ensure air valve linkage retaining clip (Figure 2, Item 1) is secured through outer mounting hole of interior door latch handle shaft weld bracket (Figure 2, Item 2).

NOTE

Make sure to properly adjust or readjust any inner door linkage following removal of any clevis retaining clip. Loosen, adjust, and then tighten jam nut. Install clevis retaining clip and verify inner door linkage for proper adjustment.

5. Adjust and tighten air valve linkage jam nut (Figure 2, Item 6) as necessary. Install original clevis retaining clip.
6. Ensure door latch linkage retaining clip (Figure 2, Item 4) is secured through outer mounting hole of latch handle shaft weld bracket (Figure 2, Item 3).
7. Adjust and tighten linkage jam nut (Figure 2, Item 5) as necessary. Install original clevis retaining clip.

CABIN DOOR LINKAGE INSPECTION AND ADJUSTMENT PROCEDURE (LOWER INTERIOR COMBAT DOOR LOCK-TYPE) - (CONTINUED)

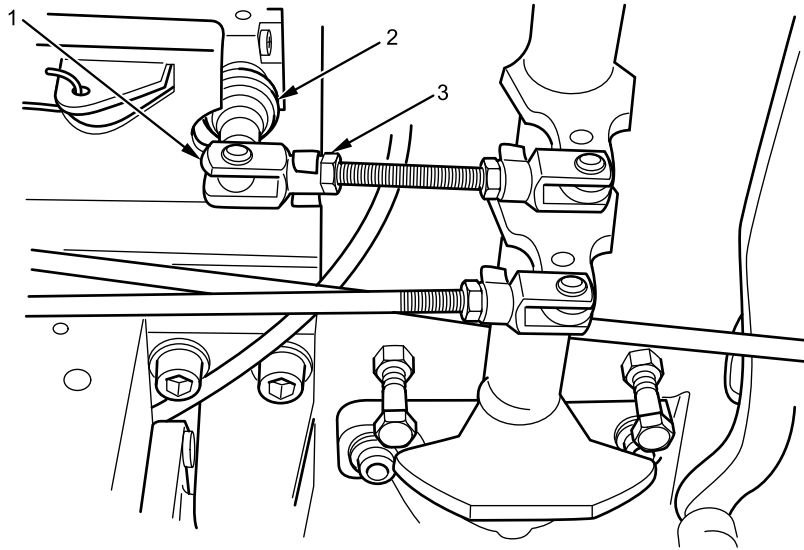

B231802217

Figure 3. Air Valve Perpendicular to Air Valve Module Face.

8. Ensure air valve linkage and linkage retaining clip (Figure 3, Item 1) are 90-degrees perpendicular to face of air valve module (Figure 3, Item 2).

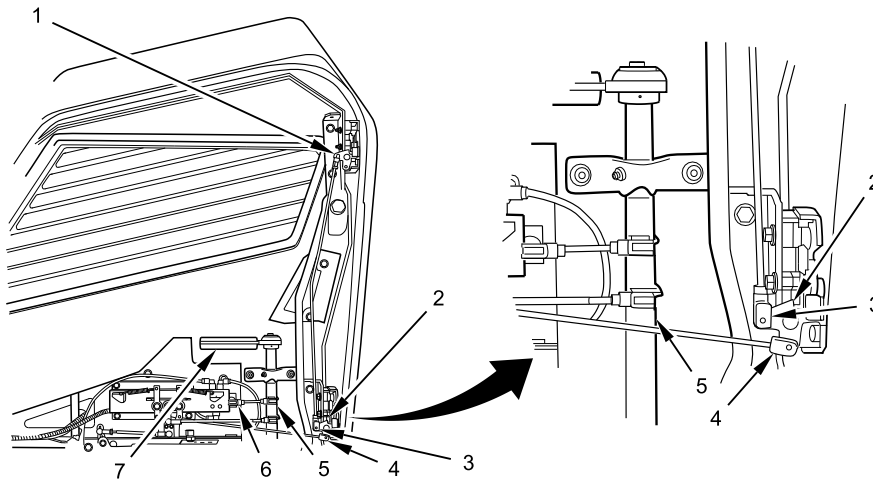

B231804690

Figure 4. Door Latches Set in Closed Position.

9. Adjust air valve linkage jam nut (Figure 3, Item 3) and linkage if necessary.
10. Set upper door latch (Figure 4, Item 1) and lower door latch (Figure 4, Item 2) in closed position.
11. Push outward on interior handle (Figure 4, Item 7) to rotate door latch handle shaft (Figure 4, Item 5) to disengage/open both door latches (Figure 4, Item 1 and 2).
12. Adjust upper door latch linkage (Figure 4, Item 3) and lower door latch linkage (Figure 4, Item 4) until an audible click is heard and both latches unlock at the same time. Ensure linkage jam nuts are adjusted as many times as necessary until both latches unlock simultaneously.

CABIN DOOR LINKAGE INSPECTION AND ADJUSTMENT PROCEDURE (LOWER INTERIOR COMBAT DOOR LOCK-TYPE) - (CONTINUED)

CAUTION

Immediately after both door latches disengage/open, air valve will engage. Ensure that door air valve does not engage before door latches release. Failure to comply may result in damage to cabin door and door components.

13. Ensure proper air valve (Figure 4, Item 6) engagement. Adjust air valve linkage and linkage jam nuts as needed.

NOTE

Door opening speed stop adjuster is located forward of inner door shaft handle assembly. Door closing speed stop adjuster is located rear of rotary door shaft assembly. Door opening and closing speed is adjusted by rotating door speed stops clockwise to increase door speed and counterclockwise to decrease door speed.

14. Loosen door speed stop locknuts (Figure 5, Item 2 and 4) and tighten door speed adjustment stop bolts (Figure 5, Item 1 and 3) as necessary for correct door operation.

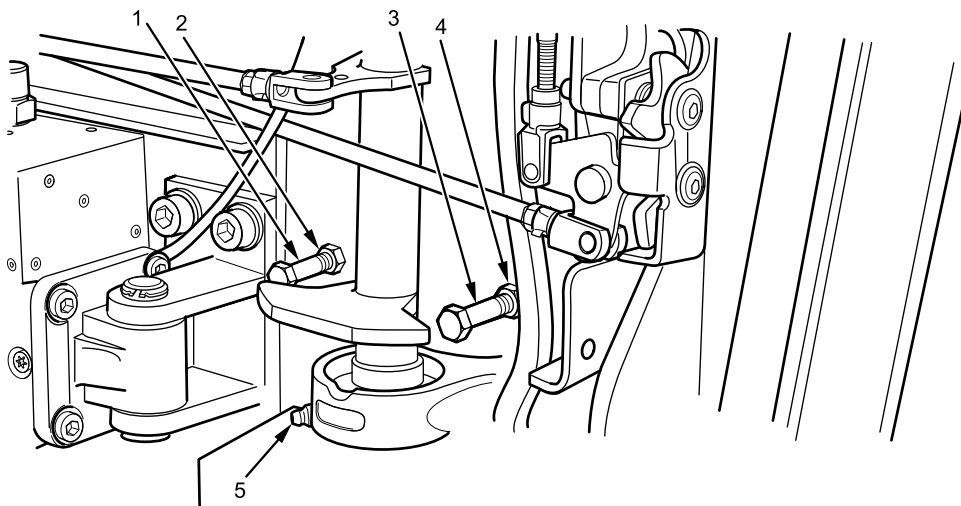

B231802219

Figure 5. Door Speed Stop Lock Nut and Adjustment Bolt.

15. Tighten door speed stop locknuts (Figure 5, Item 2 and 4) securely.
16. Apply grease to all accessible grease fittings (Figure 5, Item 5).

END OF TASK

CABIN DOOR LINKAGE INSPECTION AND ADJUSTMENT PROCEDURE (LOWER INTERIOR COMBAT DOOR LOCK-TYPE) - (CONTINUED)**FOLLOW-ON MAINTENANCE**

1. Install cabin door trim panel (WP 0626)(WP 0627).
2. Turn MAIN POWER switch on (TM 9-2355-106-10).
3. Start engine (TM 9-2355-106-10).
4. Refill air tanks (TM 9-2355-106-10).
5. Verify air pressure on gauges (TM 9-2355-106-10).
6. Remove cabin door securing chain hoists and lifting strap (WP 0608).
7. Verify proper cabin door operation and alignment. Adjust as necessary (TM 9-2355-106-10).
8. Turn engine off (TM 9-2355-106-10).
9. Turn MAIN POWER switch off (TM 9-2355-106-10).
10. Remove wheel chocks (TM 9-2355-106-10).

END OF TASK**END OF WORK PACKAGE**

FIELD MAINTENANCE
CABIN DOOR LINKAGE INSPECTION AND ADJUSTMENT PROCEDURE (UPPER COMBAT DOOR LOCK TYPE)

INITIAL SETUP:**Tools and Special Tools**

General Mechanic's Tool Kit (GMTK)
(WP 0795, Item 37)
Gun, grease (WP 0795, Item 41)

Materials/Parts

Grease (WP 0794, Item 21)
Locknut - (2) (WP 0796, Item 101)

References

TM 9-2355-106-10
TM 9-2355-106-23P
WP 0782

Equipment Condition

Parking brake set (TM 9-2355-106-10)
Transmission set in NEUTRAL (N) (TM 9-2355-106-10)
Air supply tanks at normal operating pressure (TM 9-2355-106-10)
Engine off (TM 9-2355-106-10)
MAIN POWER switch off (TM 9-2355-106-10)
Wheels chocked (TM 9-2355-106-10)
Cabin door trim panel removed (WP 0626) or (WP 0627)

WARNING

Do not use cabin door handles as hand grip to enter or exit vehicle cabin. Use of any cabin door handle as hand grip may cause air-assisted door to open or close. Failure to comply may result in injury or death to personnel.

The doors are heavy. Ensure that no one is standing directly behind the door before opening and closing it. Ensure that hands and feet are clear of the area before closing the door. Use caution when opening or closing the doors, especially when the vehicle is parked on an incline. Failure to comply may result in injury to personnel.

Caution should be used when opening and closing the side doors and rear ramp. Soldiers entering or exiting the vehicle should ensure that all body parts and gear are clear of the doors and ramps when closing. Failure to comply may result in damage to equipment and serious injury or death to personnel.

Cabin door must be secured in the open position by using heavy duty straps to prevent accidental closure during vehicle maintenance. Pull door hinge pin prior to securing door open. Failure to comply may result in serious injury or death to personnel.

Use the appropriate lifting strap sling or chain hoist for the type of load. Always clean and inspect lifting strap slings and chain hoists prior to use. Inspect for damage such as wear, corrosion, elongation, tears, or punctures. Replace lifting strap slings or chain hoists that are damaged. Failure to comply may result in component damage and death or injury to personnel.

CABIN DOOR LINKAGE INSPECTION AND ADJUSTMENT PROCEDURE (UPPER COMBAT DOOR LOCK TYPE) - (CONTINUED)

INSPECTION OF INSTALLED ITEMS

NOTE

Cabin door linkage removal and adjustment instructions should be discussed prior to starting the work package replacement task, to ensure instructions are understood by all participants. Mark and label all connections and reference areas before removal of component parts.

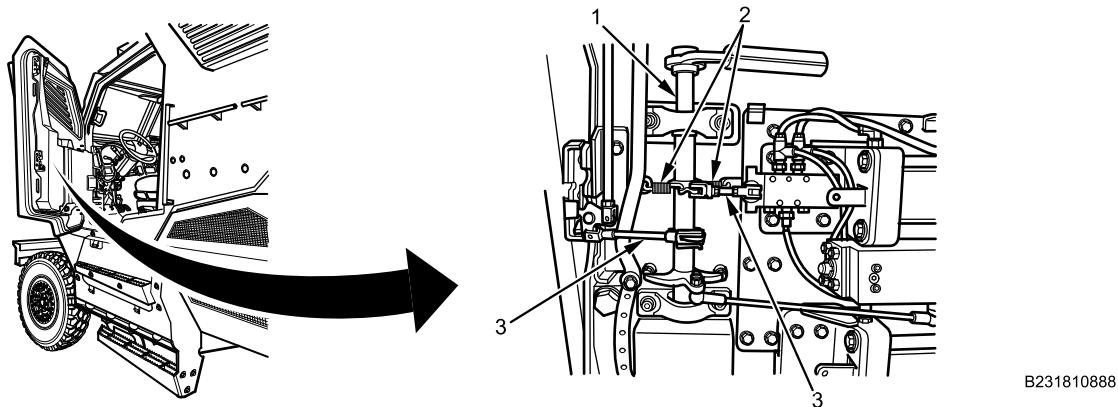

Figure 1. Inner Door Latch Handle Shaft in Neutral Position.

1. Ensure inner door latch handle shaft (Figure 1, Item 1) is not binding and is in neutral position.
2. Ensure door linkage (Figure 1, Item 3) is properly attached and secured to inner door latch handle shaft (Figure 1, Item 1).
3. Ensure two rotary latch shaft assembly return springs (Figure 1, Item 2) are properly attached and secure.

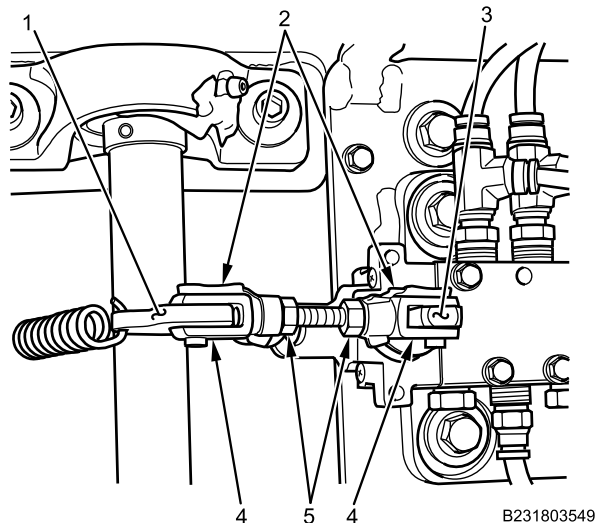

Figure 2. Air Valve Linkage Adjustment.

4. Ensure air valve linkage retaining clevis pin (Figure 2, Item 2) on latch handle shaft assembly (Figure 2, Item 1) is centered in slot. If air valve clevis pin (Figure 2, Item 2) is not centered in latch handle shaft assembly slot, adjust linkage as follows:
 - a. Hold clevises (Figure 2, Item 4) while loosening rod jam nuts (Figure 2, Item 5).
 - b. Pull clevis pin clip retainers (Figure 2, Item 2) away from clevises (Figure 2, Item 4) and pull clevis pins out to remove.

CABIN DOOR LINKAGE INSPECTION AND ADJUSTMENT PROCEDURE (UPPER COMBAT DOOR LOCK TYPE) - (CONTINUED)

- c. Remove clevis pins (Figure 2, Item 2) from latch handle shaft assembly (Figure 2, Item 1) and air valve actuator (Figure 2, Item 3).
- d. Turn clevises (Figure 2, Item 4) in or out to shorten or lengthen linkage.
- e. Install clevises (Figure 2, Item 4) on latch handle shaft assembly (Figure 2, Item 1) and air valve actuator (Figure 2, Item 3).
- f. Install clevis pin clips (Figure 2, Item 2) on clevises (Figure 2, Item 4) and push retainers on clevis pin clips (Figure 2, Item 2) into place.
- g. Tighten rod jam nuts (Figure 2, Item 5) while holding clevises (Figure 2, Item 4).

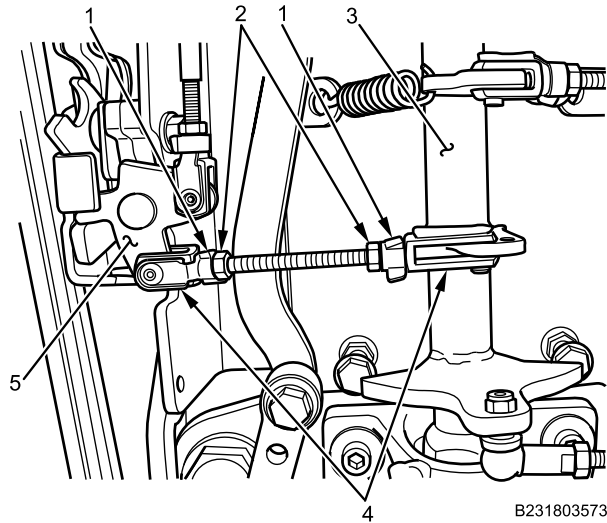
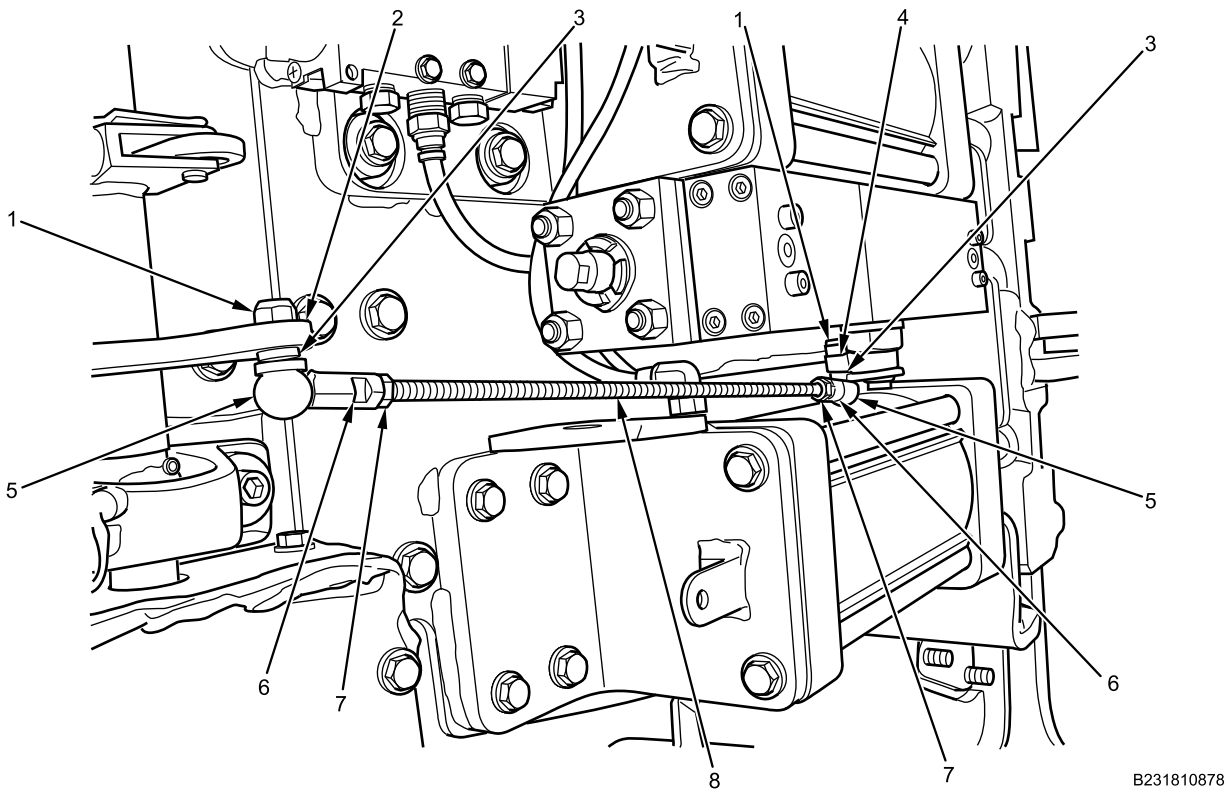

Figure 3. Door Latch Linkage Adjustment.

5. Ensure door latch linkage clevis pin clip (Figure 3, Item 1) on latch handle shaft assembly (Figure 3, Item 3) is set to rear of slot. If clevis pin clip is not set to rear of latch handle shaft assembly slot, adjust linkage as follows:
 - a. Hold clevises (Figure 3, Item 4) while loosening rod jam nuts (Figure 3, Item 2).
 - b. Pull clevis pin clip retainers (Figure 3, Item 1) away from clevises (Figure 3, Item 4) and pull clevis pin clips out to remove.
 - c. Remove clevises (Figure 3, Item 4) from latch handle shaft assembly (Figure 3, Item 3) and latch actuator (Figure 3, Item 5).
 - d. Turn clevises (Figure 3, Item 4) in or out to shorten or lengthen linkage.
 - e. Install clevises (Figure 3, Item 4) on latch handle shaft assembly (Figure 3, Item 3) and latch actuator (Figure 3, Item 5).
 - f. Install clevis pin clips in clevises (Figure 3, Item 4) and push retainers on clips (Figure 3, Item 1) into place on clevises.
 - g. Tighten rod jam nuts (Figure 3, Item 2) while holding clevises (Figure 3, Item 4).

CABIN DOOR LINKAGE INSPECTION AND ADJUSTMENT PROCEDURE (UPPER COMBAT DOOR LOCK TYPE) - (CONTINUED)

B231810878

Figure 4. Cylinder Lock Shaft Linkage Adjustment.

6. Ensure ball socket ends (Figure 4, Item 5) of the cylinder lock shaft are perpendicular to latch handle shaft assembly (Figure 4, Item 2) and cylinder assembly (Figure 4, Item 4). If ball socket ends of cylinder lock shaft linkage are not perpendicular to latch handle shaft assembly and cylinder assembly, adjust linkage as follows:
 - a. Hold ball socket flat ends (Figure 4, Item 6) while loosening jam nuts (Figure 4, Item 7).
 - b. Hold ball socket flat ends (Figure 4, Item 3) while removing locknuts (Figure 4, Item 1). Discard locknuts.
 - c. Remove linkage from latch handle shaft assembly (Figure 4, Item 2) and cylinder assembly (Figure 4, Item 4).
 - d. Turn ball sockets (Figure 4, Item 5) in or out to adjust rod length.
 - e. Install linkage in latch handle shaft assembly (Figure 4, Item 2) and cylinder assembly (Figure 4, Item 4).
 - f. Hold ball socket flat ends (Figure 4, Item 1) to install new locknuts.
 - g. Hold ball socket flats (Figure 4, Item 6) while tightening jam nuts (Figure 4, Item 7).

CABIN DOOR LINKAGE INSPECTION AND ADJUSTMENT PROCEDURE (UPPER COMBAT DOOR LOCK TYPE) - (CONTINUED)**CAUTION**

When adjusting door latch linkage, ensure door air valve does not engage before door latches release. Use air valve linkage adjustment procedure (step 5) to ensure air valve engages after door latches release. Failure to comply may result in damage to cabin door and door components.

7. Set door latches (Figure 5, Item 1) in closed position.

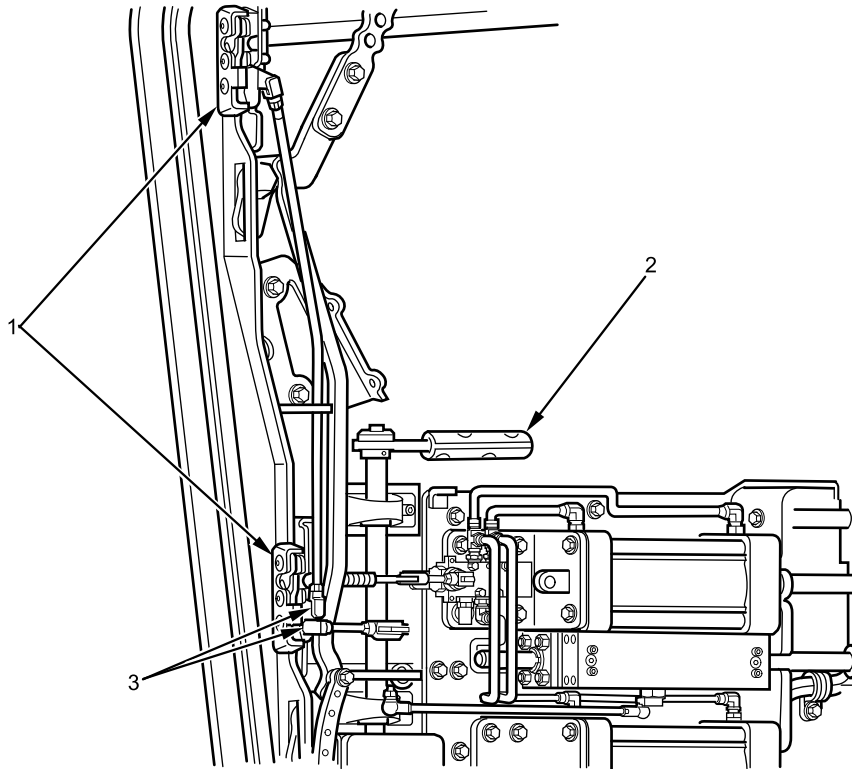

B231805252

Figure 5. Door Latch Linkage.

8. Push outward on door handle (Figure 5, Item 2) to unlock door latches (Figure 5, Item 1) with upper and lower door latch linkage (Figure 5, Item 3). If door latches do not unlock, adjust lower door latch linkage as follows:
 - a. Hold clevises (Figure 6, Item 4) while loosening rod jam nuts (Figure 6, Item 2).

CABIN DOOR LINKAGE INSPECTION AND ADJUSTMENT PROCEDURE (UPPER COMBAT DOOR LOCK TYPE) - (CONTINUED)

Figure 6. Lower Door Latch Adjustment.

- b. Pull retainers on clips (Figure 6, Item 1) away from clevises (Figure 6, Item 4) and pull clips out to remove pins.
- c. Remove clevises (Figure 6, Item 4) from latch handle shaft assembly (Figure 6, Item 3) and latch actuator (Figure 6, Item 5).
- d. Turn clevises (Figure 6, Item 4) in or out to shorten or lengthen linkage.
- e. Install clevises (Figure 6, Item 4) on latch handle shaft assembly (Figure 6, Item 3) and latch actuator (Figure 6, Item 5).
- f. Install clip pins in clevises (Figure 6, Item 4) and push retainers on clips (Figure 6, Item 1) into place on clevises.
- g. Tighten rod jam nuts (Figure 6, Item 2) while holding clevises (Figure 6, Item 4).

CABIN DOOR LINKAGE INSPECTION AND ADJUSTMENT PROCEDURE (UPPER COMBAT DOOR LOCK TYPE) - (CONTINUED)

Figure 7. Upper Door Latch Linkage Adjustment.

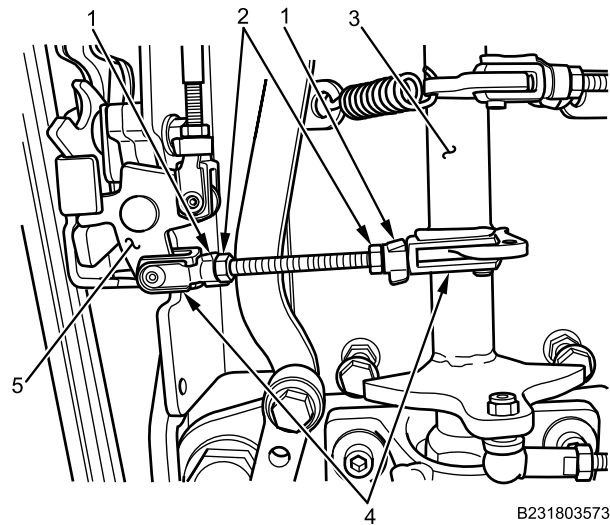
9. Ensure that both latches unlock at the same time. If door latches do not unlock at same time, adjust upper door latch linkage as follows:
 - a. Hold upper linkage clevises (Figure 7, Item 2 and 6) while loosening rod jam nuts (Figure 7, Item 4 and 8).
 - b. Pull retainers on clevis pin clips (Figure 7, Item 1 and 5) away from clevises (Figure 7, Item 2 and 6) and pull clips out to remove pins.
 - c. Remove clevises (Figure 7, Item 2 and 6) from lower and upper latch assemblies (Figure 7, Item 3 and 7).
 - d. Turn clevises (Figure 7, Item 2 and 6) in or out to shorten or lengthen linkage.
 - e. Install clevises (Figure 7, Item 2 and 6) on lower and upper latch assemblies (Figure 7, Item 3 and 7).
 - f. Install clip pins in clevises (Figure 7, Item 2 and 6) and push retainers on clips (Figure 7, Item 1 and 5) into place on clevises.
 - g. Tighten rod jam nuts (Figure 7, Item 4 and 8) while holding clevises (Figure 7, Item 2 and 6).

CABIN DOOR LINKAGE INSPECTION AND ADJUSTMENT PROCEDURE (UPPER COMBAT DOOR LOCK TYPE) - (CONTINUED)

NOTE

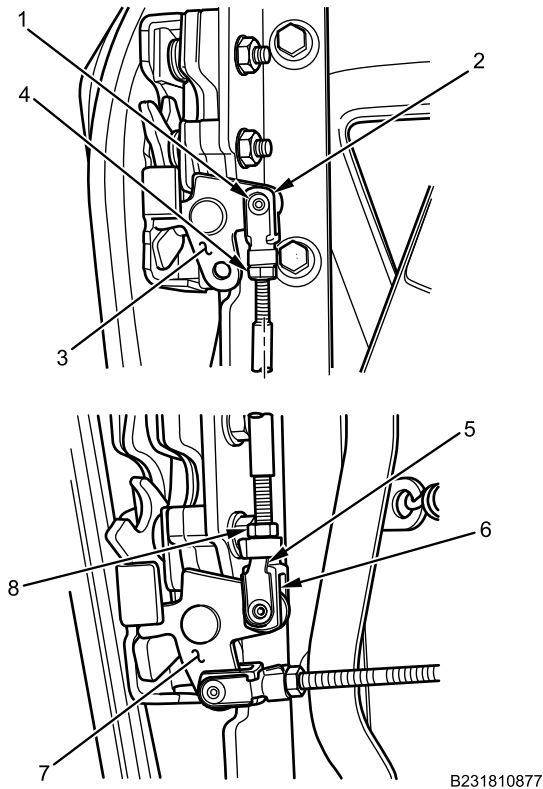
Door opening speed stop adjuster is located forward of inner door shaft handle assembly. Door closing speed stop adjuster is located behind rotary door shaft assembly. Door opening and closing speed is adjusted by rotating door speed stops clockwise to increase door speed, and counterclockwise to decrease door speed.

10. Loosen door speed stop locking nut (Figure 8, Item 1) and adjust bolts (Figure 8, Item 2) as necessary for correct door operation.

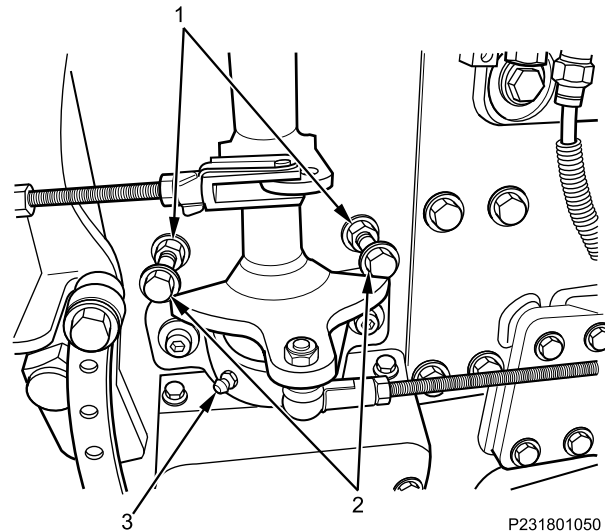

Figure 8. Door Speed Stop Adjusting Bolts.

11. Tighten door speed stop locking nut (Figure 8, Item 1) securely.
12. Using grease gun, apply grease to all fittings (Figure 8, Item 3).

END OF TASK

FOLLOW-ON MAINTENANCE

1. Start engine (TM 9-2355-106-10).
2. Allow pressure in air tanks to build to normal operating pressure (TM 9-2355-106-10).
3. Verify air pressure on gauges (TM 9-2355-106-10).
4. Remove cabin door chain hoists and lifting strap (WP 0608).
5. Verify proper cabin door operation and alignment. Adjust as necessary.
6. Turn engine off (TM 9-2355-106-10).
7. Install cabin door trim panel (WP 0626)(WP 0627).
8. Remove wheel chocks (TM 9-2355-106-10).

END OF TASK

END OF WORK PACKAGE

FIELD MAINTENANCE
DUAL-PNEUMATIC DOOR ACTUATOR REMOVAL AND INSTALLATION

INITIAL SETUP:**Tools and Special Tools**

General Mechanic's Tool Kit (GMTK)
(WP 0795, Item 37)

Personnel Required

Maintainer - (2)

References

TM 9-2355-106-10
TM 9-2355-106-23P
WP 0782

Equipment Condition

Parking brake set (TM 9-2355-106-10)

Transmission set in NEUTRAL (N) (TM
9-2355-106-10)

Engine off (TM 9-2355-106-10)

MAIN POWER switch off (TM 9-2355-106-10)

Wheels chocked (TM 9-2355-106-10)

Air tanks and reservoirs drained (TM 9-2355-106-10)

Cabin door secured safely open (WP 0608)

Cabin door interior handle assembly removed
(WP 0628)

Cabin door trim panel removed (WP 0626) or
(WP 0627)

REMOVAL
WARNING

Cab door must be secured in the open position by using heavy duty winch straps to prevent accidental closure during vehicle maintenance. Pull door hinge pin prior to securing door open. Failure to comply may result in serious injury or death to personnel.

Use the appropriate lifting strap sling or chain hoist for the type of load. Always clean and inspect lifting strap slings and chain hoists prior to use. Inspect for damage such as wear, corrosion, elongation, tears, or punctures. Replace lifting strap slings or chain hoists that are damaged. Failure to comply may result in component damage and death or injury to personnel.

NOTE

Cabin door linkage removal and adjustment instructions should be discussed prior to starting the work package replacement task, to ensure instructions are understood by all participants. Mark and label all connections and reference areas before removal of component parts.

DUAL-PNEUMATIC DOOR ACTUATOR REMOVAL AND INSTALLATION - (CONTINUED)

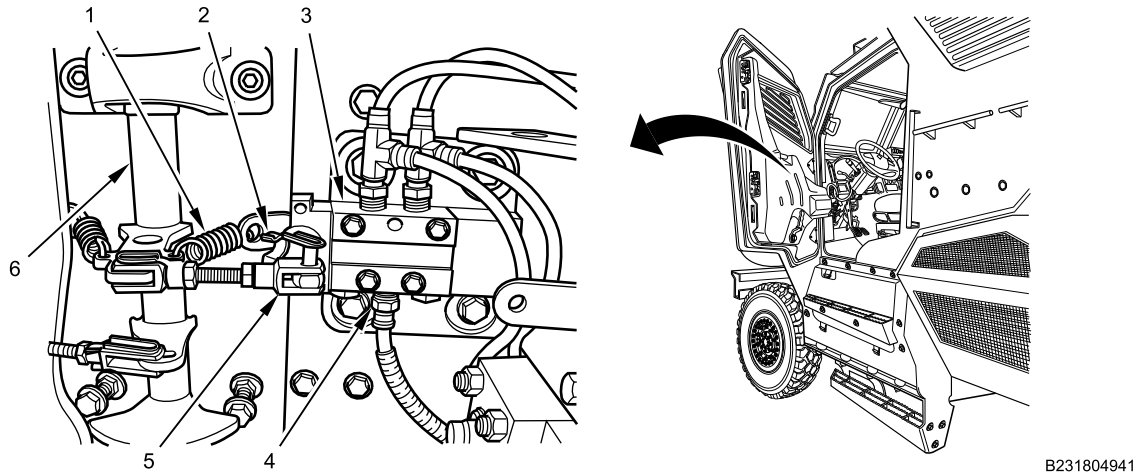

Figure 1. Door Actuator Air Line and Pin.

1. Disconnect air supply line (Figure 1, Item 4) from door actuator (Figure 1, Item 3).
2. Remove spring (Figure 1, Item 1) from door handle shaft (Figure 1, Item 6) and door actuator (Figure 1, Item 3).
3. Remove pin (Figure 1, Item 2) securing air valve linkage (Figure 1, Item 5). Position linkage aside.

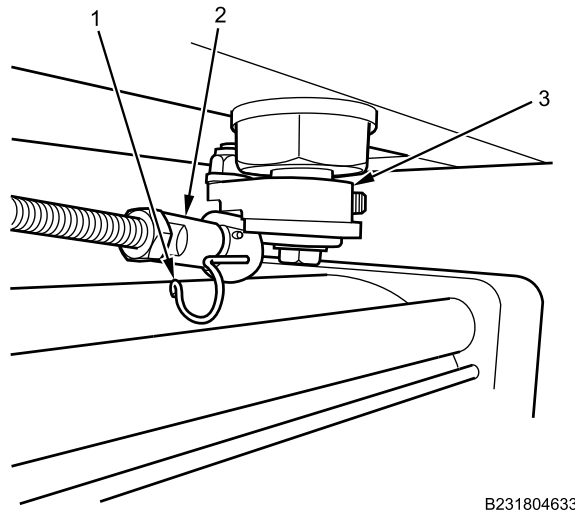

Figure 2. Door Actuator Latch Linkage Rod.

4. Remove latch linkage rod pin (Figure 2, Item 1) from door latch linkage rod (Figure 2, Item 2).
5. Disconnect latch linkage rod (Figure 2, Item 2) from door actuator (Figure 2, Item 3).

DUAL-PNEUMATIC DOOR ACTUATOR REMOVAL AND INSTALLATION - (CONTINUED)

Figure 3. Outside Mirror Harness.

6. Disconnect outside mirror harness connector (Figure 3, Item 2) located near door hinge pillar (Figure 3, Item 1).

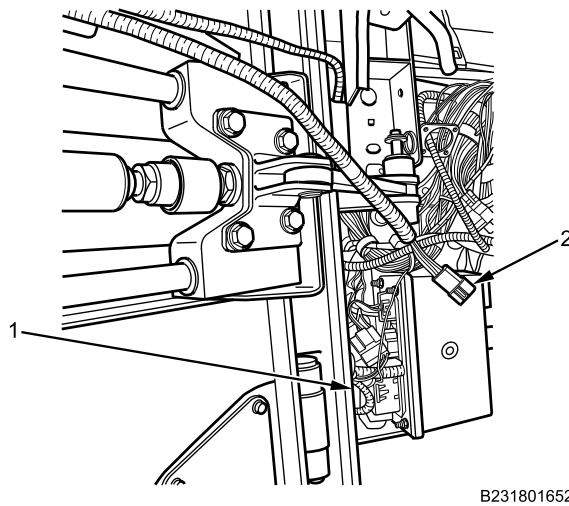
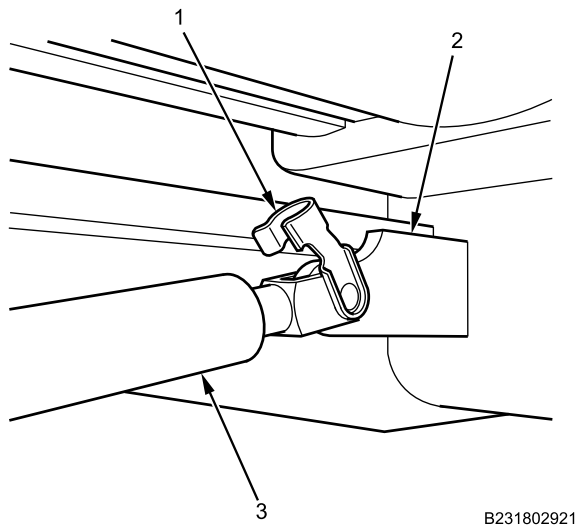
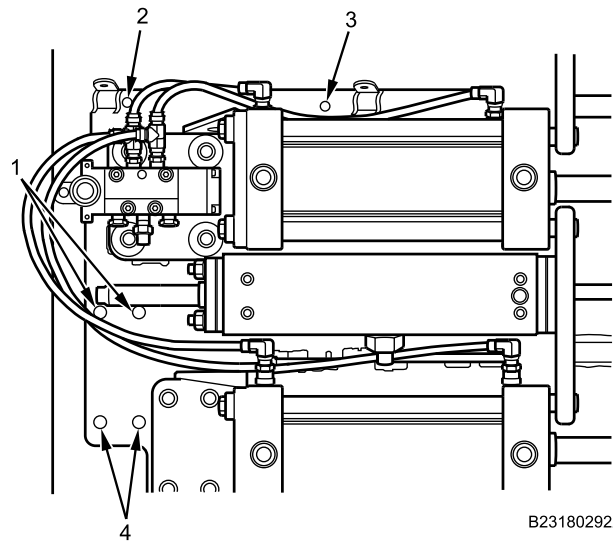

Figure 4. Combat Lock Linkage.

7. Remove retaining pin (Figure 4, Item 1) attaching combat lock link (Figure 4, Item 3) to door actuator (Figure 4, Item 2).

DUAL-PNEUMATIC DOOR ACTUATOR REMOVAL AND INSTALLATION - (CONTINUED)



B231802922

Figure 5. Door Actuator.

8. Remove door actuator bolts (Figure 5, Item 1, 2, 3, and 4) from door actuator.

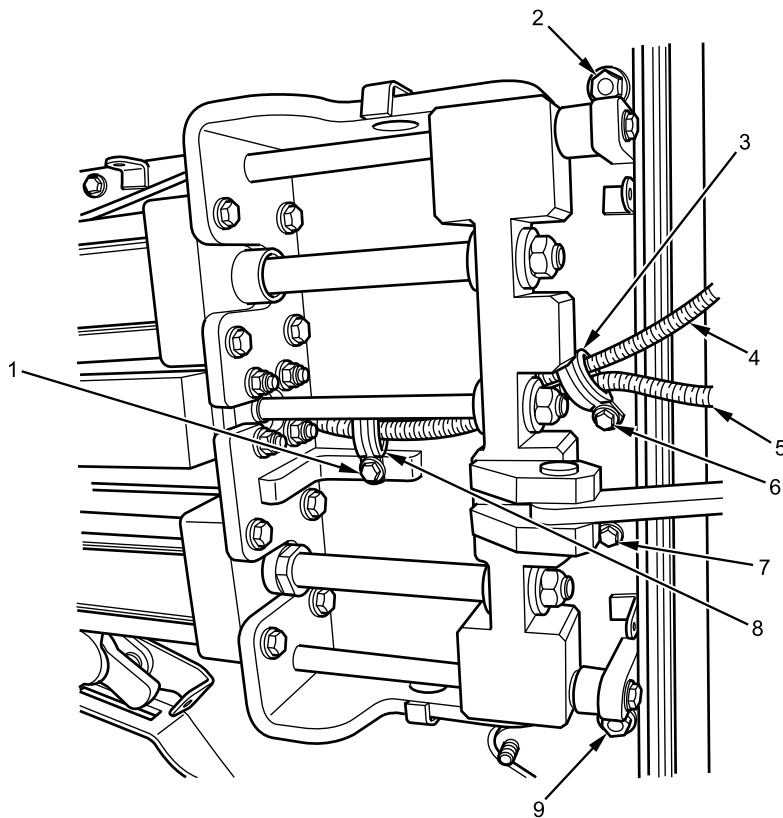

B231802923

Figure 6. Door Actuator.

9. Remove two bolts (Figure 6, Item 1 and 6) and retainers (Figure 6, Item 3 and 8) from door actuator air line (Figure 6, Item 4) and outside mirror harness (Figure 6, Item 5).
10. Remove door actuator air line (Figure 6, Item 4) from door actuator.
11. With assistance, support door actuator while removing bolt (Figure 6, Item 7) and nuts (Figure 6, Item 2 and 9).

DUAL-PNEUMATIC DOOR ACTUATOR REMOVAL AND INSTALLATION - (CONTINUED)

- Remove door actuator from door, routing outside mirror harness (Figure 6, Item 5) through hole in door actuator. Set door actuator aside.

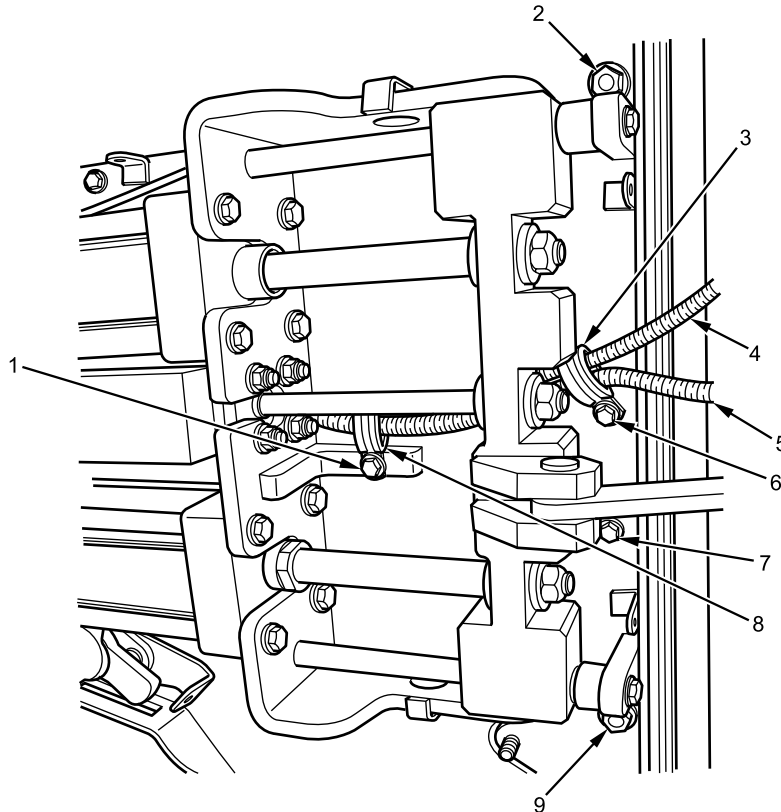
END OF TASK**INSTALLATION**

B231802923

Figure 7. Door Actuator Installation.

- With assistance, position door actuator to door while routing outside mirror harness (Figure 7, Item 5) through hole in door actuator.
- Install nuts (Figure 7, Item 2 and 9) and bolt (Figure 7, Item 7) finger tight.
- Position door actuator air line (Figure 7, Item 4) and outside mirror harness (Figure 7, Item 5) through retainers (Figure 7, Item 3 and 8) and install retainer bolts (Figure 7, Item 1 and 6) finger tight.

DUAL-PNEUMATIC DOOR ACTUATOR REMOVAL AND INSTALLATION - (CONTINUED)

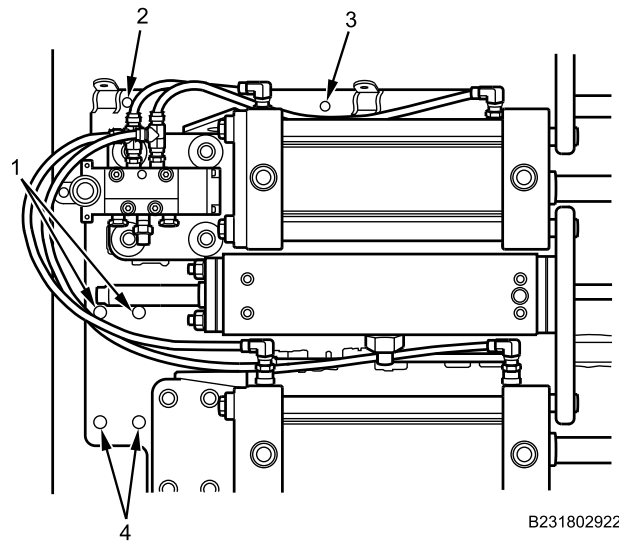

B231802922

Figure 8. Pneumatic Door Actuator Bolts.

4. Install door actuator bolts (Figure 8, Item 1, 2, 3, and 4) on door actuator.
5. Tighten all door actuator nuts and bolts securely.

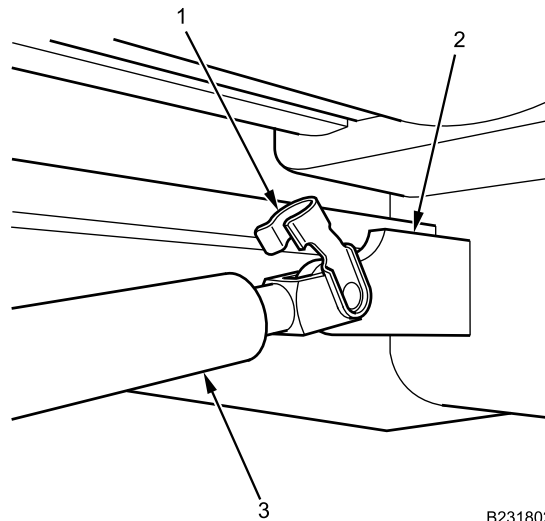

B231802921

Figure 9. Combat Lock Linkage.

6. Install combat lock link (Figure 9, Item 3) on door actuator (Figure 9, Item 2) with retaining pin (Figure 9, Item 1) and snap into place.

DUAL-PNEUMATIC DOOR ACTUATOR REMOVAL AND INSTALLATION - (CONTINUED)

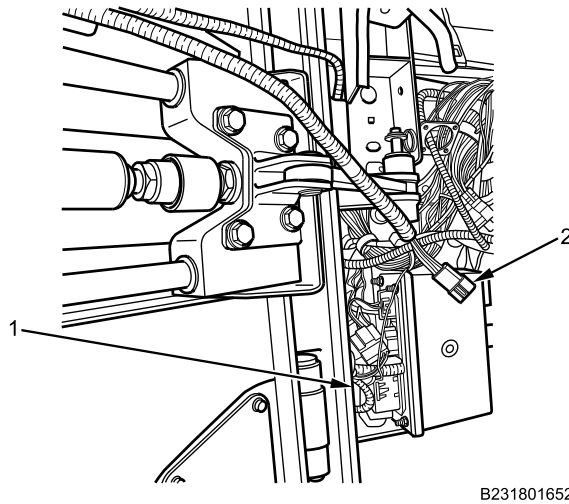

B231801652

Figure 10. Outside Mirror Harness.

7. Connect outside mirror harness connector (Figure 10, Item 2) located near door hinge pillar (Figure 10, Item 1).

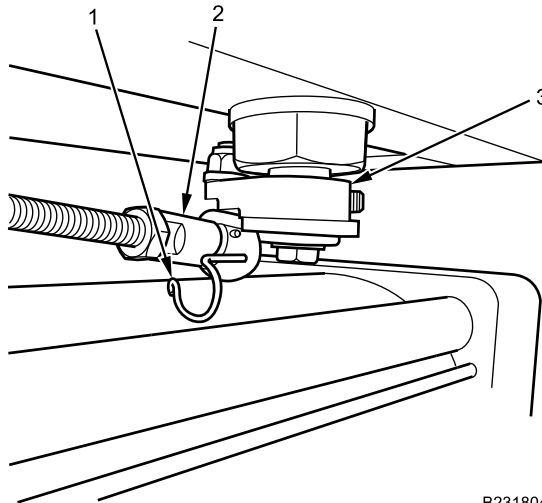

B231804633

Figure 11. Door Actuator Latch Linkage Rod.

8. Connect latch linkage rod (Figure 11, Item 2) to door actuator assembly (Figure 11, Item 3).
9. Install latch linkage rod pin (Figure 11, Item 1) on door latch linkage rod (Figure 11, Item 2) and snap into place.

DUAL-PNEUMATIC DOOR ACTUATOR REMOVAL AND INSTALLATION - (CONTINUED)

Figure 12. Door Actuator Air Line and Pin.

10. Position air valve linkage (Figure 12, Item 5) to door actuator (Figure 12, Item 3) and install linkage rod pin (Figure 12, Item 2).
11. Install spring (Figure 12, Item 1) on door handle shaft (Figure 12, Item 6) and door actuator (Figure 12, Item 3).
12. Install air supply line (Figure 12, Item 4) on door actuator (Figure 12, Item 3).

END OF TASK**FOLLOW-ON MAINTENANCE**

1. Install cabin door interior handle assembly (WP 0628).
2. Install cabin door trim panel (WP 0626) or (WP 0627).
3. Remove cabin door securing chain hoists and lifting strap (WP 0608).
4. Turn MAIN POWER switch on (TM 9-2355-106-10).
5. Start engine and allow air pressure to build to normal operating range (TM 9-2355-106-10).
6. Verify exterior and interior door handle assemblies, inner cabin door latch assembly, and exterior door latch for proper operation. Adjust as required if door fails to latch or if any handle does not work properly (WP 0615) or (WP 0616).
7. Turn engine off (TM 9-2355-106-10).
8. Turn MAIN POWER switch off (TM 9-2355-106-10).
9. Remove wheel chocks (TM 9-2355-106-10).

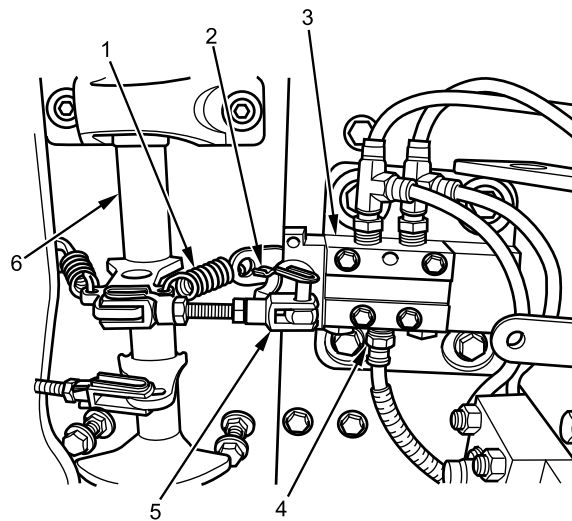
END OF TASK**END OF WORK PACKAGE**

FIELD MAINTENANCE**CABIN DOOR ASSIST SYSTEM ACTUATOR AIR LINE TUBING REMOVAL AND INSTALLATION**

INITIAL SETUP:**Tools and Special Tools**

General Mechanic's Tool Kit (GMTK)
(WP 0795, Item 37)

Materials/Parts

Rag (WP 0794, Item 39)

References

TM 9-2355-106-10
TM 9-2355-106-23P
WP 0782

Equipment Condition

Parking brake set (TM 9-2355-106-10)
Transmission set in NEUTRAL (N) (TM
9-2355-106-10)
Engine off (TM 9-2355-106-10)
MAIN POWER switch off (TM 9-2355-106-10)
Wheels chocked (TM 9-2355-106-10)
Air tanks and reservoirs drained (TM 9-2355-106-10)
Cabin door secured safely open (WP 0626)
Cabin door trim panel removed (WP 0626) or
(WP 0627)

WARNING

Cabin door must be secured in the open position by using heavy duty straps to prevent accidental closure during vehicle maintenance. Pull check link retaining pin prior to securing door open. Failure to comply may result in serious injury or death to personnel.

NOTE

Left side shown, right side similar.

Note air line routing before removal to aid installation.

CABIN DOOR ASSIST SYSTEM ACTUATOR AIR LINE TUBING REMOVAL AND INSTALLATION - (CONTINUED)

REMOVAL

1. Disconnect top actuator air line tubing (Figure 1, Item 2) from door actuator fittings (Figure 1, Item 3).

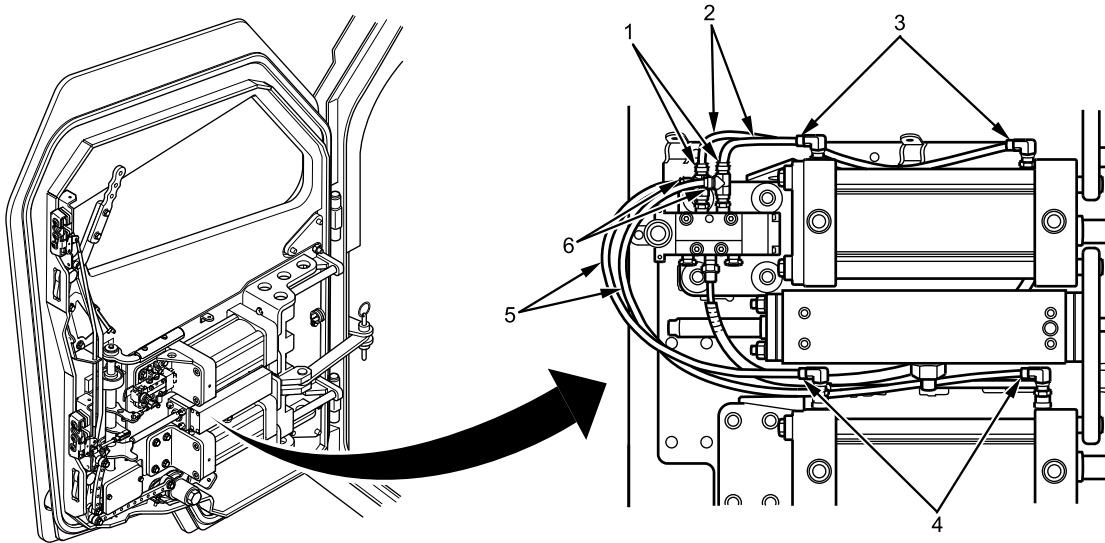

B231810722

Figure 1. Actuator Air Lines.

2. Disconnect top actuator air line tubing (Figure 1, Item 2) from door actuator tee fittings (Figure 1, Item 1) and remove air line tubing.
3. Disconnect lower actuator air line tubing (Figure 1, Item 5) from door actuator fittings (Figure 1, Item 4).
4. Disconnect lower actuator air line tubing (Figure 1, Item 5) from door actuator tees (Figure 1, Item 6).

END OF TASK

CABIN DOOR ASSIST SYSTEM ACTUATOR AIR LINE TUBING REMOVAL AND INSTALLATION - (CONTINUED)

INSTALLATION

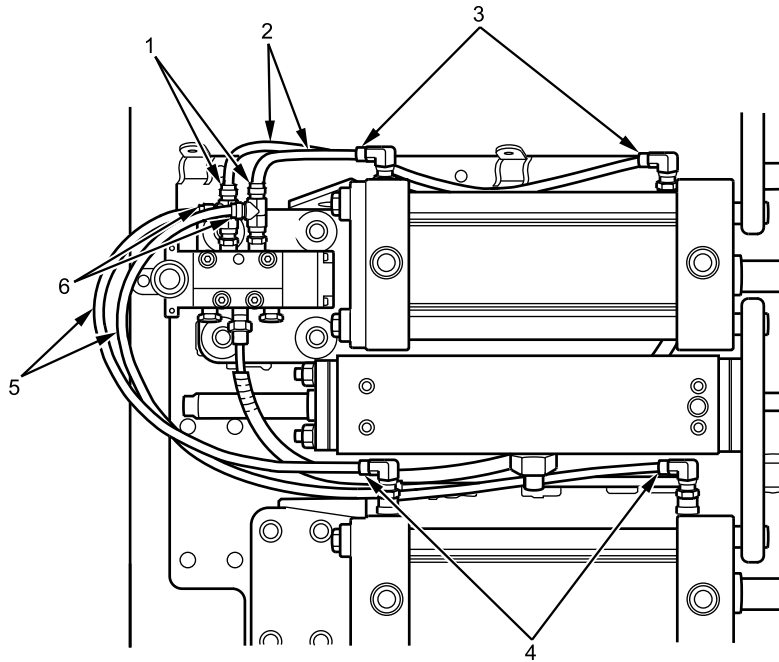

B231810723

Figure 2. Tubing Replacement.

1. Connect lower actuator air line tubing (Figure 2, Item 5) on door actuator tees (Figure 2, Item 6).
2. Connect lower actuator air line tubing (Figure 2, Item 5) on door actuator fittings (Figure 2, Item 4).
3. Connect top actuator air line tubing (Figure 2, Item 2) on door actuator tee fittings (Figure 2, Item 1).
4. Connect top actuator air line tubing (Figure 2, Item 2) on door actuator fittings (Figure 2, Item 3).

END OF TASK

FOLLOW-ON MAINTENANCE

1. Turn MAIN POWER switch on (TM 9-2355-106-10).
2. Start engine, refill air tanks, and verify air pressure on interior vehicle gauges (TM 9-2355-106-10).
3. Close cabin door and verify actuator operates correctly (TM 9-2355-106-10).
4. Turn engine off (TM 9-2355-106-10).
5. Turn MAIN POWER switch off (TM 9-2355-106-10).
6. Install cabin door trim panel (WP 0626) or (WP 0627).
7. Remove wheel chocks (TM 9-2355-106-10).

END OF TASK

END OF WORK PACKAGE

FIELD MAINTENANCE**LEFT DOOR AIR SUPPLY LINE REMOVAL AND INSTALLATION**

INITIAL SETUP:**Tools and Special Tools**

General Mechanic's Tool Kit (GMTK)
(WP 0795, Item 37)

Materials/Parts

Cable lock strap - (2) (WP 0796, Item 134)
Marker, identification, wire (WP 0794, Item 33)

References

TM 9-2355-106-10
TM 9-2355-106-23P
WP 0782

Equipment Condition

Parking brake set (TM 9-2355-106-10)
Transmission set in NEUTRAL (N) (TM 9-2355-106-10)
Engine off (TM 9-2355-106-10)
MAIN POWER switch off (TM 9-2355-106-10)
Wheels chocked (TM 9-2355-106-10)
Cabin door secured safely open (WP 0608)
Air tanks and reservoirs drained (TM 9-2355-106-10)
Cabin door trim panel removed (WP 0626) or (WP 0627)

REMOVAL**WARNING**

The doors are heavy. Ensure that no one is standing directly behind the door before opening and closing it. Ensure that hands and feet are clear of the area before closing the door. Use caution when opening or closing the doors, especially when the vehicle is parked on an incline. Failure to comply may result in injury to personnel.

Cabin door must be secured in the open position by using heavy duty straps to prevent accidental closure during vehicle maintenance. Pull check link retaining pin prior to securing door open. Failure to comply may result in serious injury or death to personnel.

Use the appropriate lifting sling and chain hoist for the type of load. Clean lifting strap slings and chain hoists prior to use, and inspect for damage such as wear, corrosion, elongation, tears, or punctures. Replace lifting strap slings and chain hoists that are damaged. Failure to comply may result in damage to equipment and injury or death to personnel.

Do not disconnect any air line or fitting until system pressure has been relieved. Hoses may whip and injure personnel, and air under pressure can penetrate skin. Failure to comply may result in serious injury or death to personnel.

NOTE

Tag air lines and note routing to aid installation.

LEFT DOOR AIR SUPPLY LINE REMOVAL AND INSTALLATION - (CONTINUED)

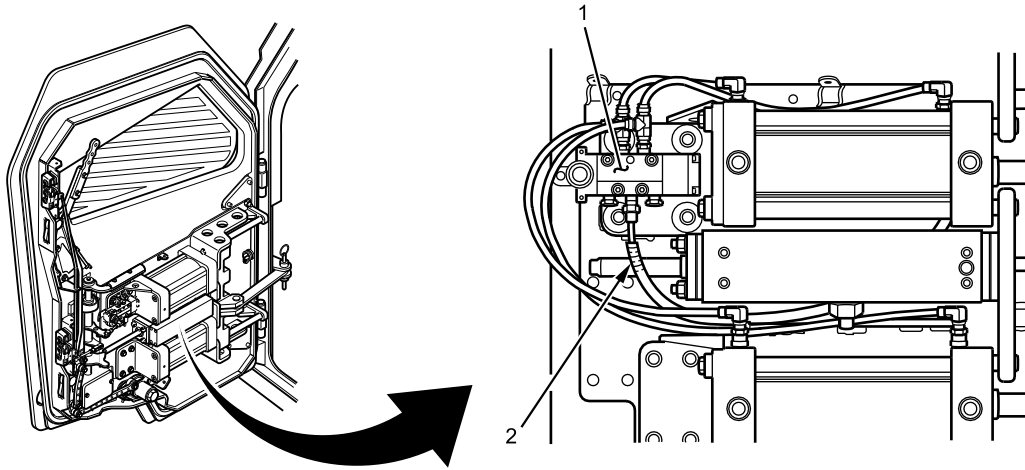

B230605883

Figure 1. Supply Air Line Tubing.

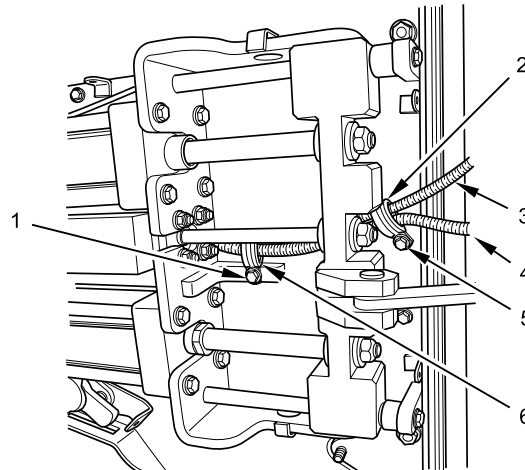

B230605865

Figure 2. Supply Air Line Tubing Retainers.

1. Disconnect supply air line tubing (Figure 1, Item 2) from door actuator (Figure 1, Item 1).
2. Remove two bolts (Figure 2, Item 1 and 5) and retainers (Figure 2, Item 2 and 6) from door supply air line tubing (Figure 2, Item 3) and outside mirror harness (Figure 2, Item 4).

LEFT DOOR AIR SUPPLY LINE REMOVAL AND INSTALLATION - (CONTINUED)

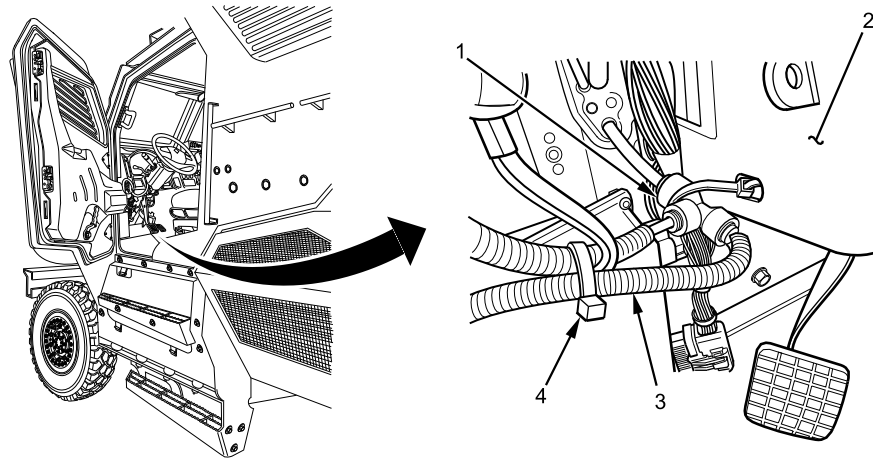

B230605878

Figure 3. Supply Air Line Tubing Tee.

3. Remove door supply air line tubing (Figure 2, Item 3) from door.
4. Follow supply air line tubing (Figure 3, Item 3) to driver control mounting bracket (Figure 3, Item 2) and remove supply air line tubing from air tube tee (Figure 3, Item 1).
5. Remove and discard cable lock strap (Figure 3, Item 4). Remove supply air line tubing (Figure 3, Item 3).

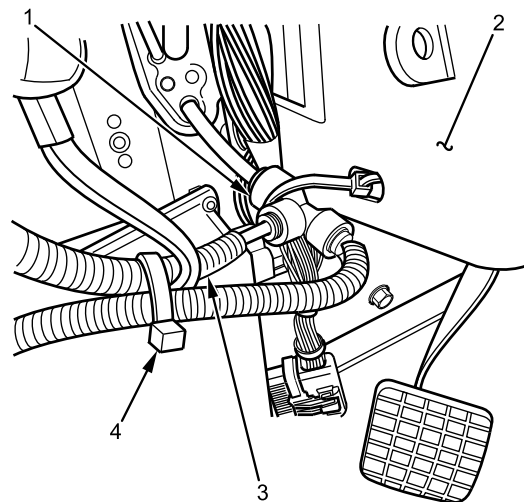
END OF TASK**INSTALLATION**

B230605874

Figure 4. Air Line Tubing Tee.

1. Install supply air line tubing (Figure 4, Item 3) to air line tubing tee (Figure 4, Item 1) on driver control mounting bracket (Figure 4, Item 2).
2. Install new cable lock straps (Figure 4, Item 4) as needed.

LEFT DOOR AIR SUPPLY LINE REMOVAL AND INSTALLATION - (CONTINUED)

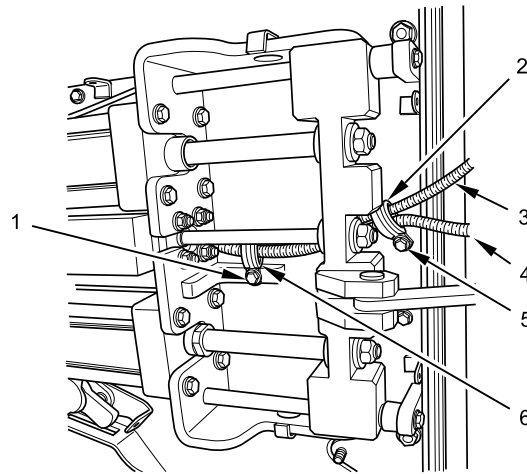

B230605865

Figure 5. Supply Air Line Tubing Retainers.

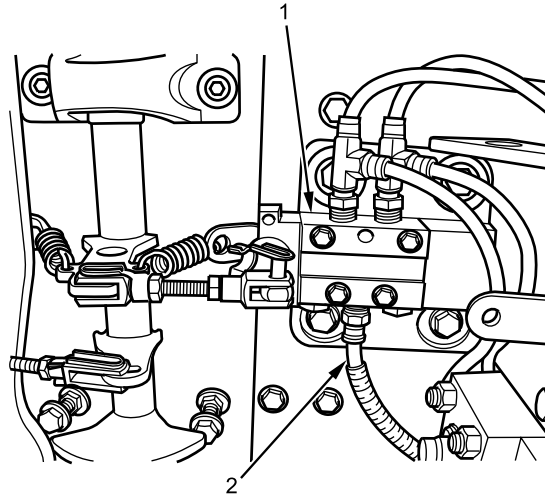

B230605871

Figure 6. Door Actuator.

3. Install supply air line tubing (Figure 5, Item 3), and outside mirror harness (Figure 5, Item 4) through retainers (Figure 5, Item 2 and 6). Install retainer bolts (Figure 5, Item 1 and 5) finger tight.
4. Install supply air line tubing (Figure 6, Item 2) on door actuator (Figure 6, Item 1).
5. Tighten retainer bolts securely.

END OF TASK

LEFT DOOR AIR SUPPLY LINE REMOVAL AND INSTALLATION - (CONTINUED)**FOLLOW-ON MAINTENANCE**

1. Turn MAIN POWER switch on (TM 9-2355-106-10).
2. Start engine (TM 9-2355-106-10).
3. Build air pressure to above 75 psi (TM 9-2355-106-10).
4. Inspect for air leaks (TM 9-2355-106-10).
5. Verify air pressure on interior vehicle gauges (TM 9-2355-106-10).
6. Turn engine off (TM 9-2355-106-10).
7. Turn MAIN POWER switch off (TM 9-2355-106-10).
8. Install cabin door trim panel (WP 0626) or (WP 0627).
9. Close and secure cabin door (WP 0608).
10. Remove wheel chocks (TM 9-2355-106-10).

END OF TASK**END OF WORK PACKAGE**

FIELD MAINTENANCE
RIGHT CABIN DOOR ASSIST SYSTEM SUPPLY AIR LINE TUBING REMOVAL AND INSTALLATION

INITIAL SETUP:**Tools and Special Tools**

General Mechanic's Tool Kit (GMTK)
(WP 0795, Item 37)

Materials/Parts

Cable lock strap - (2) (WP 0796, Item 134)
Marker, identification, wire (WP 0794, Item 33)

References

TM 9-2355-106-10
TM 9-2355-106-23P
WP 0782

Equipment Condition

Parking brake set (TM 9-2355-106-10)
Transmission set in NEUTRAL (N) (TM 9-2355-106-10)
Engine off (TM 9-2355-106-10)
MAIN POWER switch off (TM 9-2355-106-10)
Wheels chocked (TM 9-2355-106-10)
Air tanks and reservoirs drained (TM 9-2355-106-10)
Cabin door secured safely open (WP 0608)
Cabin door trim panel removed (WP 0626) or (WP 0627)

REMOVAL**WARNING**

Do not use cabin door handles as hand grip to enter or exit vehicle cabin. Use of any cabin door handle as hand grip may cause air-assisted door to open or close. Failure to comply may result in injury or death to personnel.

The doors are heavy. Ensure that no one is standing directly behind the door before opening and closing it. Ensure that hands and feet are clear of the area before closing the door. Use caution when opening or closing the doors, especially when the vehicle is parked on an incline. Failure to comply may result in injury to personnel.

Caution should be used when opening and closing the side doors and rear ramp. Soldiers entering or exiting the vehicle should ensure that all body parts and gear are clear of the doors and ramps when closing. Failure to comply may result in damage to equipment and serious injury or death to personnel.

Personnel must utilize seat restraints, and each occupant must ensure that their seat restraint is properly fastened and adjusted. Failure to comply may result in serious injury to personnel.

Cabin door must be secured in the open position by using heavy duty straps to prevent accidental closure during vehicle maintenance. Pull check link retaining pin prior to securing door open. Failure to comply may result in serious injury or death to personnel.

Do not disconnect any air line or fitting until system pressure has been relieved. Hoses may whip and injure personnel, and air under pressure can penetrate skin. Failure to comply may result in serious injury or death to personnel.

RIGHT CABIN DOOR ASSIST SYSTEM SUPPLY AIR LINE TUBING REMOVAL AND INSTALLATION - (CONTINUED)

NOTE

Tag air lines/routing to aid installation.

1. Disconnect supply air line tubing (Figure 1, Item 2) from door actuator (Figure 1, Item 1).

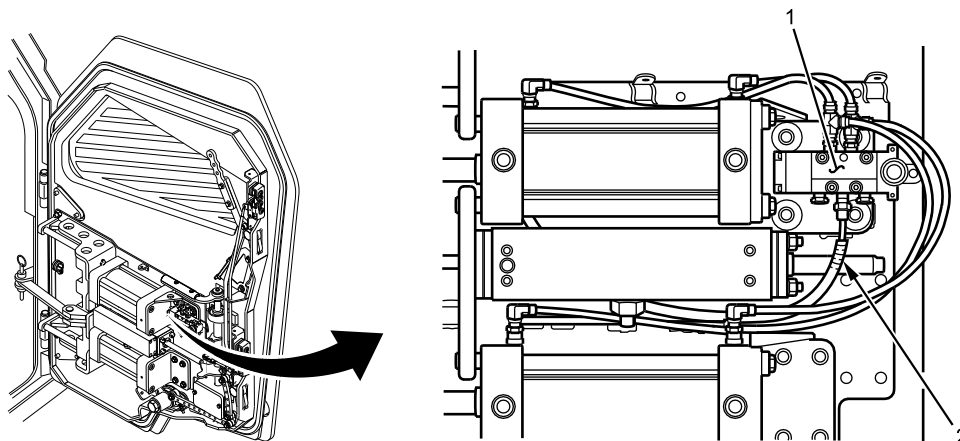

B230605881

Figure 1. Supply Air Line Tubing.

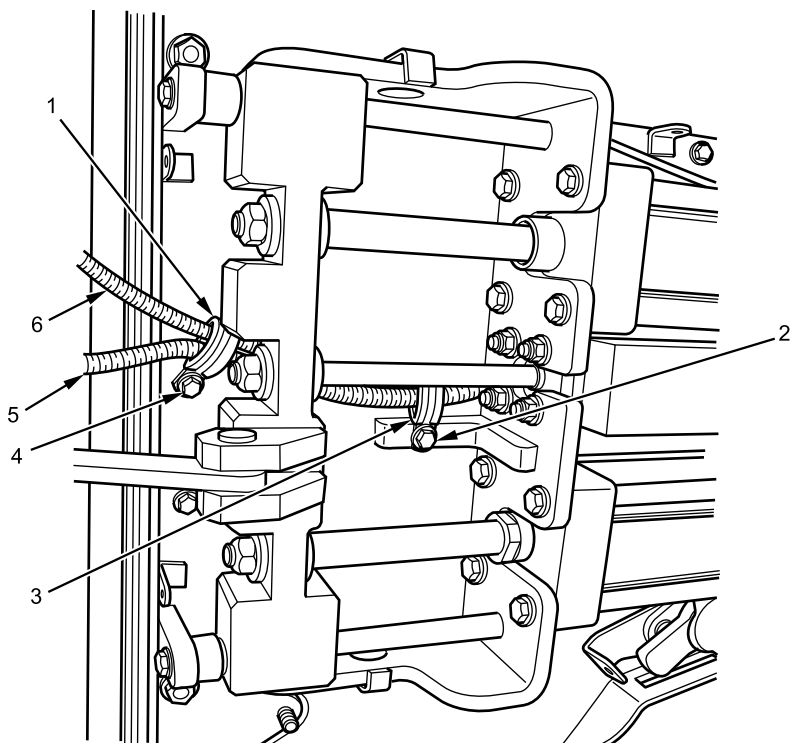

B230605903

Figure 2. Supply Air Line Tubing Retainers.

2. Remove two bolts (Figure 2, Item 2 and 4) and retainers (Figure 2, Item 1 and 3) from door supply air line tubing (Figure 2, Item 6) and outside mirror harness (Figure 2, Item 5).
3. Remove door supply air line tubing (Figure 2, Item 6) from door.

RIGHT CABIN DOOR ASSIST SYSTEM SUPPLY AIR LINE TUBING REMOVAL AND INSTALLATION - (CONTINUED)

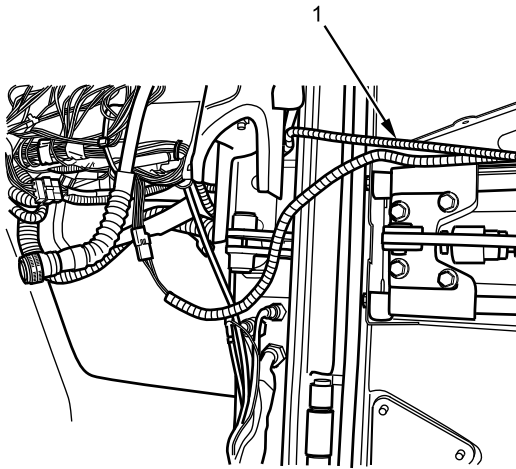

B230605884

Figure 3. Follow Air Line To Left Side Of Vehicle.

4. Follow supply air line tubing (Figure 3, Item 1) under instrument panel to left side of vehicle.

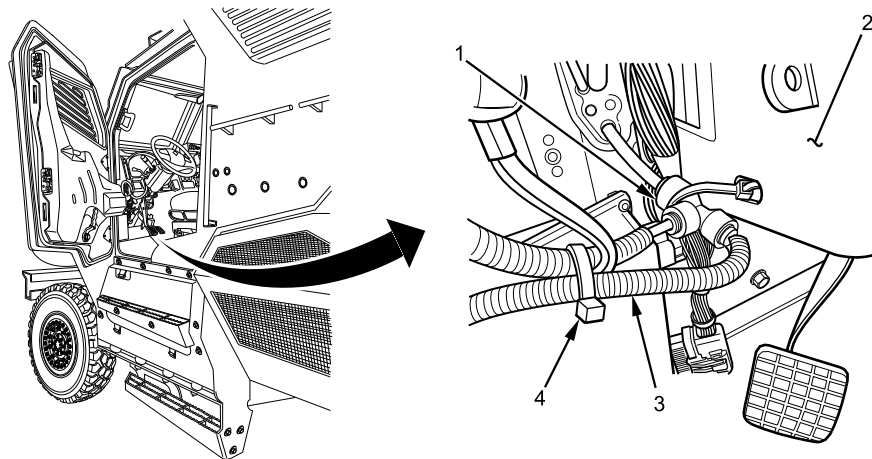

B230605867

Figure 4. Supply Air Line Tubing Tee, Located On Left Side Of Vehicle.

5. At driver control mounting bracket (Figure 4, Item 2) remove supply air line tubing (Figure 4, Item 3) from air line tube tee (Figure 4, Item 1).
6. Remove and discard cable lock strap (Figure 4, Item 4) and supply air line tubing.

END OF TASK

**RIGHT CABIN DOOR ASSIST SYSTEM SUPPLY AIR LINE TUBING REMOVAL AND INSTALLATION -
(CONTINUED)****INSTALLATION**

1. Install supply air line tubing (Figure 5, Item 3) to air line tube tee (Figure 5, Item 1) on driver control mounting bracket (Figure 5, Item 2).

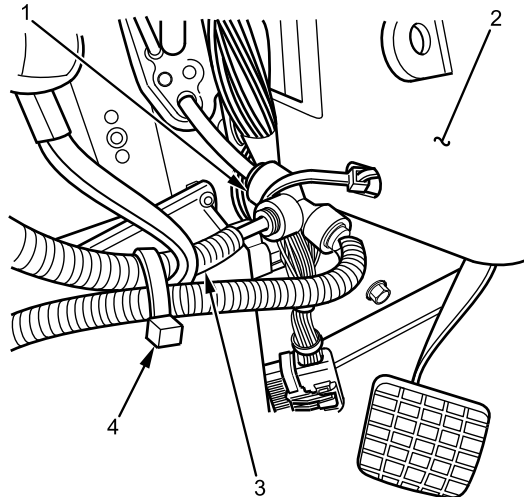

B230605874

Figure 5. Air Line Tubing Tee.

2. Install new cable lock straps as needed (Figure 5, Item 4).

**RIGHT CABIN DOOR ASSIST SYSTEM SUPPLY AIR LINE TUBING REMOVAL AND INSTALLATION -
(CONTINUED)**

3. Install supply air line tubing (Figure 6, Item 6) and outside mirror harness (Figure 6, Item 5) through retainers (Figure 6, Item 1 and 3) and install retainer bolts (Figure 6, Item 2 and 4) finger tight.

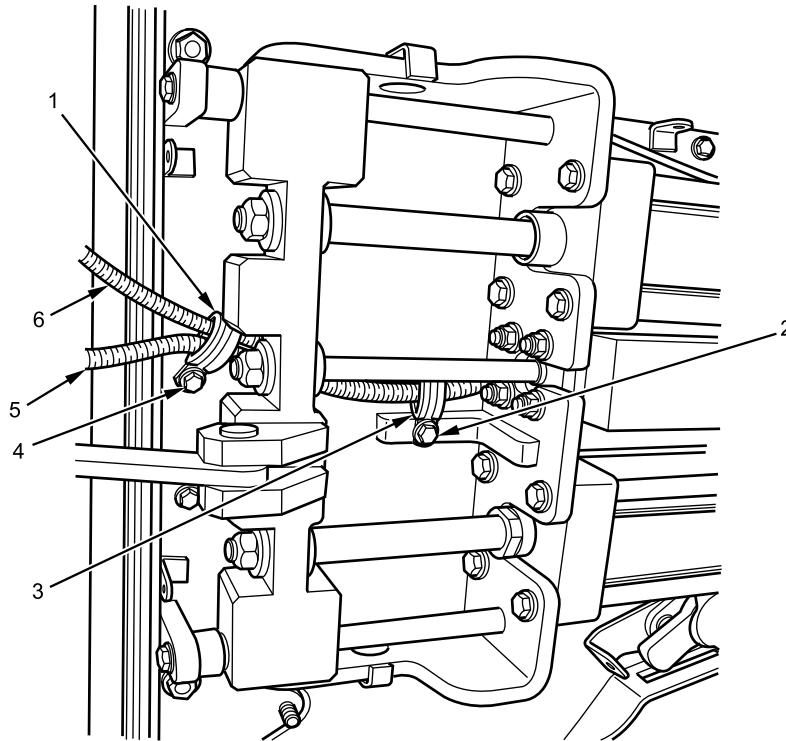

B230605903

Figure 6. Supply Air Line Tubing Retainers.

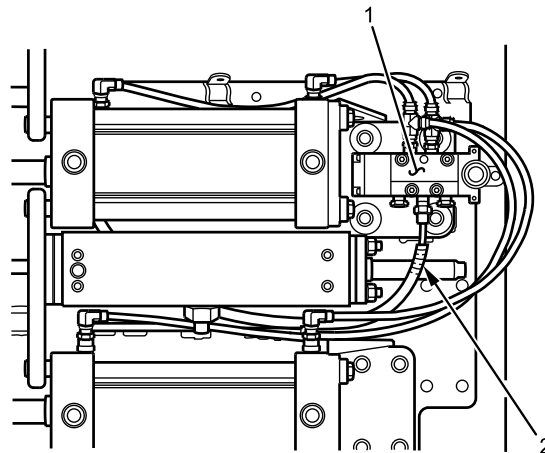
**RIGHT CABIN DOOR ASSIST SYSTEM SUPPLY AIR LINE TUBING REMOVAL AND INSTALLATION -
(CONTINUED)**

B230605880

Figure 7. Door Actuator.

4. Install supply air line tubing (Figure 7, Item 2) on door actuator (Figure 7, Item 1).
5. Tighten retainer bolts securely.
6. Check for leaks with soapy water.

END OF TASK**FOLLOW-ON MAINTENANCE**

1. Turn MAIN POWER switch on (TM 9-2355-106-10).
2. Start engine (TM 9-2355-106-10).
3. Refill air tanks (TM 9-2355-106-10).
4. Verify air pressure on interior vehicle gauges (TM 9-2355-106-10).
5. Turn engine off (TM 9-2355-106-10).
6. Turn MAIN POWER switch off (TM 9-2355-106-10).
7. Install cabin door trim panel (WP 0626) or (WP 0627).
8. Remove chain hoists and lifting strap securing cabin door (WP 0608).
9. Remove wheel chocks (TM 9-2355-106-10).

END OF TASK**END OF WORK PACKAGE**

FIELD MAINTENANCE

CABIN DOOR ASSIST SYSTEM SUPPLY PASS-THROUGH AIR LINE TUBING REMOVAL AND INSTALLATION

INITIAL SETUP:

Tools and Special Tools

General Mechanic's Tool Kit (GMTK)
(WP 0795, Item 37)

Materials/Parts

Goggles, industrial (WP 0794, Item 20)

References

TM 9-2355-106-10
TM 9-2355-106-23P
WP 0782

Equipment Condition

Parking brake set (TM 9-2355-106-10)

Transmission set in NEUTRAL (N) (TM 9-2355-106-10)

Engine off (TM 9-2355-106-10)

MAIN POWER switch off (TM 9-2355-106-10)

Wheels chocked (TM 9-2355-106-10)

Air pressure drained from all air brake reservoirs (TM 9-2355-106-10)

Battery cables disconnected (WP 0404)

Cabin door secured safely open (WP 0608)

Left side engine armor plate removed (WP 0597)

Air cleaner assembly removed (WP 0257)

Air cleaner support removed (WP 0258)

Driver control mounting bracket assembly exterior armor removed (WP 0646)

REMOVAL

WARNING



Cabin door must be secured in the open position by using heavy duty straps to prevent accidental closure during vehicle maintenance. Pull check link retaining pin prior to securing door open. Failure to comply may result in serious injury or death to personnel.

Use the appropriate lifting sling and chain hoist for the type of load. Clean lifting strap slings and chain hoists prior to use, and inspect for damage such as wear, corrosion, elongation, tears, or punctures. Replace lifting strap slings and chain hoists that are damaged. Failure to comply may result in damage to equipment and injury or death to personnel.

Engine hood is extremely heavy and requires two-person lift. Ensure that there is adequate space in front of the vehicle to open hood completely without pinning or pinching personnel between hood and any other structure. Use extreme care when working under hood and make sure it is properly supported. Failure to comply may result in serious injury or death to personnel.

Air drain valves are under pressure. Wear protective goggles and do not place face in front of air drain valves while draining air reservoirs. Open air drain valves slowly to release air pressure gradually. Failure to comply may result in serious injury or death to personnel.

Do not disconnect any air line or fitting until system pressure has been relieved. Hoses may whip and injure personnel, and air under pressure can penetrate skin. Failure to comply may result in serious injury or death to personnel.

NOTE

Note size and location of cable lock straps to aid installation.

**CABIN DOOR ASSIST SYSTEM SUPPLY PASS-THROUGH AIR LINE TUBING REMOVAL AND INSTALLATION
- (CONTINUED)**

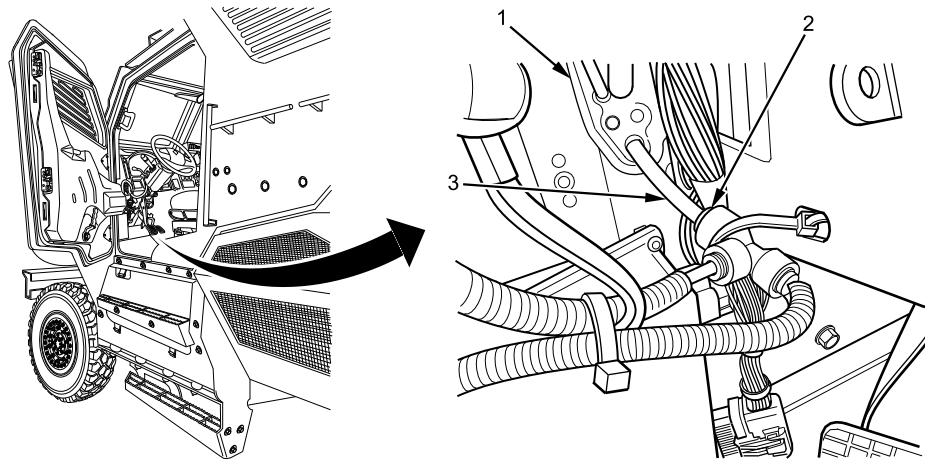

B230605914

Figure 1. Door Actuator Air Line Tube.

1. Disconnect BLUE door actuator supply air line tube (Figure 1, Item 3) from door actuator supply tee (Figure 1, Item 2) at left air line grommet (Figure 1, Item 1).

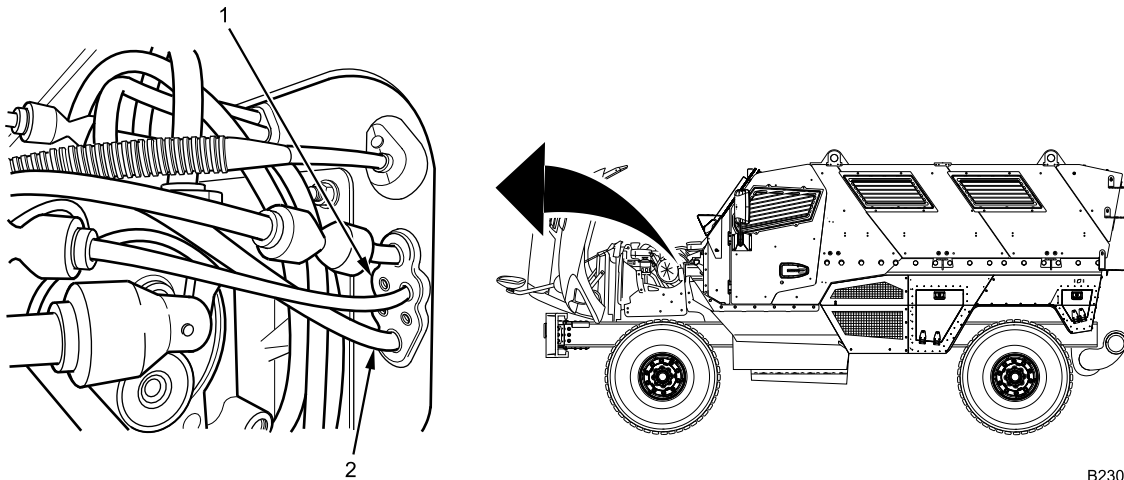

B230605917

Figure 2. Exterior Air Lines.

2. Remove BLUE door actuator supply air line tube (Figure 2, Item 2) from left air line grommet (Figure 2, Item 1).

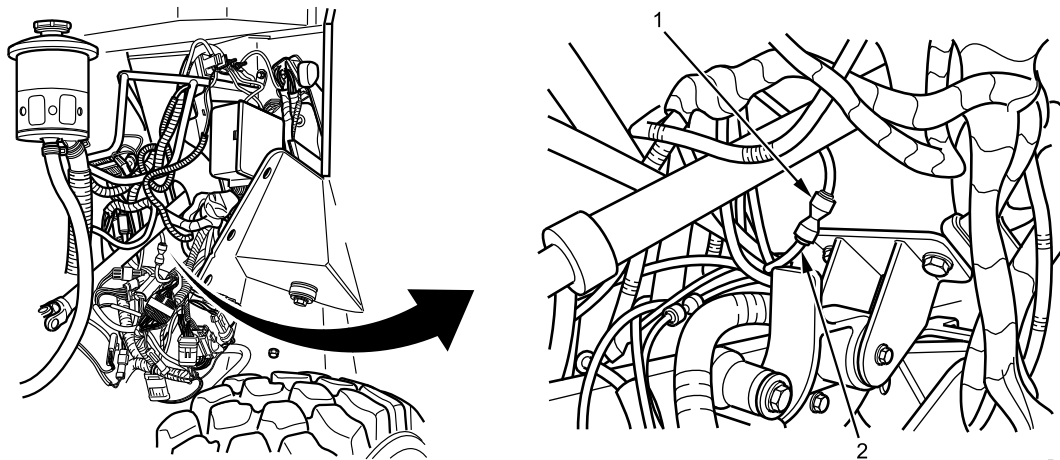
**CABIN DOOR ASSIST SYSTEM SUPPLY PASS-THROUGH AIR LINE TUBING REMOVAL AND INSTALLATION
- (CONTINUED)**

B231805695

Figure 3. Air Line Union.

3. Remove BLUE door actuator supply air line tube (Figure 3, Item 2) from union (Figure 3, Item 1).

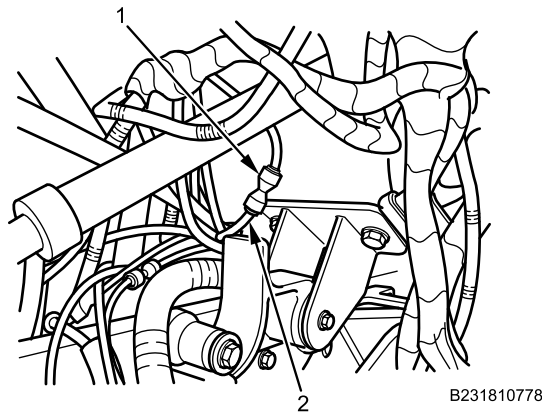
END OF TASK**INSTALLATION**

B231810778

Figure 4. Air Line Union Installation.

1. Install BLUE door actuator supply air line tube (Figure 4, Item 2) on union (Figure 4, Item 1).

CABIN DOOR ASSIST SYSTEM SUPPLY PASS-THROUGH AIR LINE TUBING REMOVAL AND INSTALLATION - (CONTINUED)

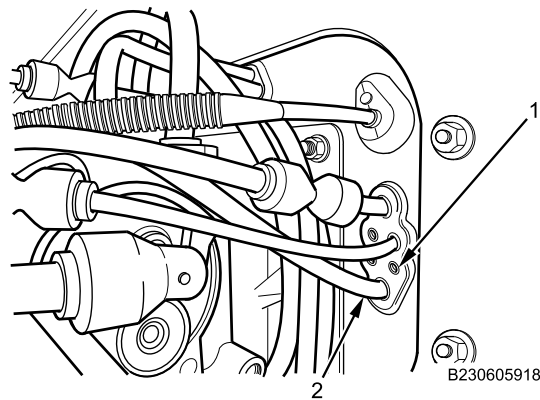

Figure 5. Exterior Air Lines.

2. Install BLUE door actuator supply air line tube (Figure 5, Item 2) on left air line grommet (Figure 5, Item 1).

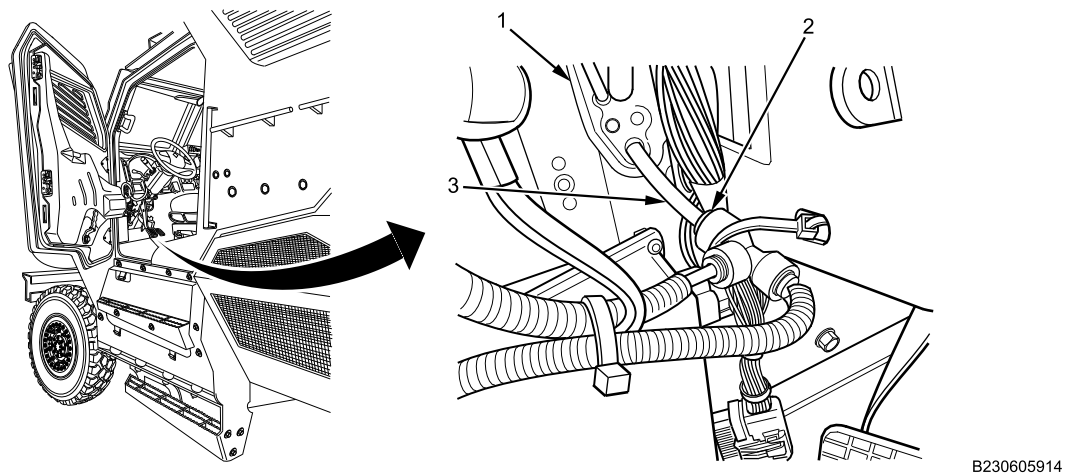

Figure 6. Door Actuator Air Line Tube.

3. Connect BLUE door actuator supply air line tube (Figure 6, Item 3) on door actuator supply tee (Figure 6, Item 2) at left air line grommet (Figure 6, Item 1).

END OF TASK

**CABIN DOOR ASSIST SYSTEM SUPPLY PASS-THROUGH AIR LINE TUBING REMOVAL AND INSTALLATION
- (CONTINUED)****FOLLOW-ON MAINTENANCE**

1. Install driver control mounting bracket assembly exterior armor (WP 0646).
2. Install air cleaner support (WP 0258).
3. Install left side engine armor plate (WP 0597).
4. Connect battery cables (WP 0404).
5. Start engine (TM 9-2355-106-10).
6. Build air pressure to normal operation (TM 9-2355-106-10).
7. Inspect for air leaks (TM 9-2355-106-10).
8. Turn engine off (TM 9-2355-106-10).
9. Turn MAIN POWER switch off (TM 9-2355-106-10).
10. Install air cleaner assembly (WP 0257).
11. Close and secure cabin door (WP 0608).
12. Close and secure engine hood (TM 9-2355-106-10).
13. Remove wheel chocks (TM 9-2355-106-10).

END OF TASK**END OF WORK PACKAGE**

FIELD MAINTENANCE

CABIN DOOR ASSIST SYSTEM SUPPLY AIR LINE TUBING REMOVAL AND INSTALLATION

INITIAL SETUP:

Tools and Special Tools

General Mechanic's Tool Kit (GMTK)
(WP 0795, Item 37)

Materials/Parts

Goggles, industrial (WP 0794, Item 20)
Cable lock strap (WP 0796, Item 124)

Personnel Required

Maintainer (2)

References

WP 0782

Equipment Condition

Parking brake set (TM 9-2355-106-10)
Transmission set in NEUTRAL (N) (TM 9-2355-106-10)
Engine off (TM 9-2355-106-10)
MAIN POWER switch off (TM 9-2355-106-10)
Wheels chocked (TM 9-2355-106-10)
Engine hood open and secure (TM 9-2355-106-10)
Air pressure drained from all air brake reservoirs (TM 9-2355-106-10)
Left engine armor plate removed (WP 0597)
Belly armor removed (WP 0606)
Air cleaner assembly removed (WP 0257)

WARNING



Engine hood is extremely heavy and requires two-person lift. Ensure that there is adequate space in front of the vehicle to open hood completely without pinning or pinching personnel between hood and any other structure. Use extreme care when working under hood and make sure it is properly supported. Failure to comply may result in serious injury or death to personnel.

Air drain valves are under pressure. Wear protective goggles and do not place face in front of air drain valves while draining air reservoirs. Open air drain valves slowly to release air pressure gradually. Failure to comply may result in serious injury or death to personnel.

Do not disconnect any air line or fitting until system pressure has been relieved. Hoses may whip and injure personnel, and air under pressure can penetrate skin. Failure to comply may result in serious injury or death to personnel.

CABIN DOOR ASSIST SYSTEM SUPPLY AIR LINE TUBING REMOVAL AND INSTALLATION - (CONTINUED)**REMOVAL****NOTE**

Note location and number of cable lock straps to aid installation.

1. Remove BLUE supply air line tubing (Figure 1, Item 1) from primary air tank fitting (Figure 1, Item 2).

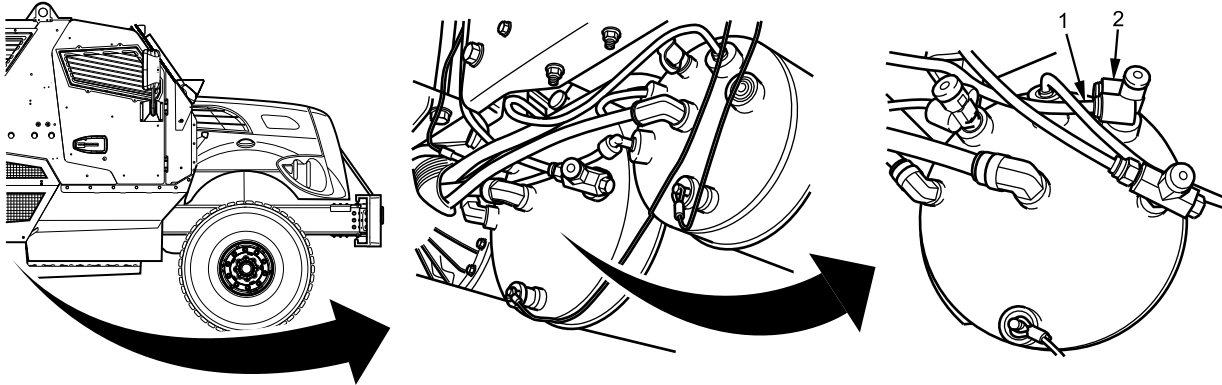

B231805697

Figure 1. Primary and Supply Tanks.

2. Follow BLUE supply air line tubing (Figure 1, Item 1) under vehicle body and remove all cable lock straps.

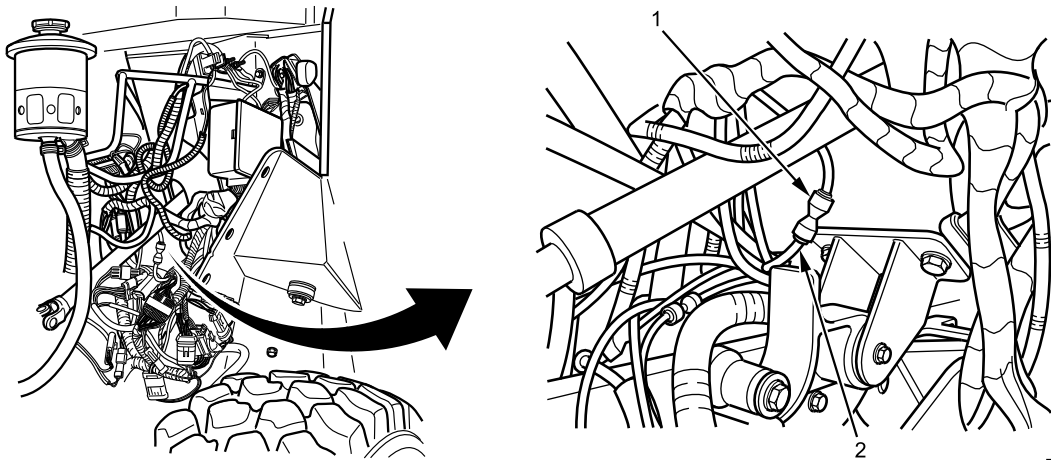

B231805695

Figure 2. Air Line Union.

3. Remove BLUE supply air line tubing (Figure 2, Item 2) from union connection (Figure 2, Item 1).
4. Remove and discard cable lock straps and BLUE supply air line tubing.

END OF TASK

CABIN DOOR ASSIST SYSTEM SUPPLY AIR LINE TUBING REMOVAL AND INSTALLATION - (CONTINUED)**INSTALLATION**

Figure 3. Supply Air Line Tubing.

1. Install BLUE supply air line tubing (Figure 3, Item 2) on union connection (Figure 3, Item 1).
2. With assistant, route BLUE supply air line tubing (Figure 3, Item 2) from left side frame rail over tail shaft of transmission to primary air tank on right frame rail.
3. Install BLUE supply air line tubing (Figure 4, Item 1) on primary air tank fitting (Figure 4, Item 2).

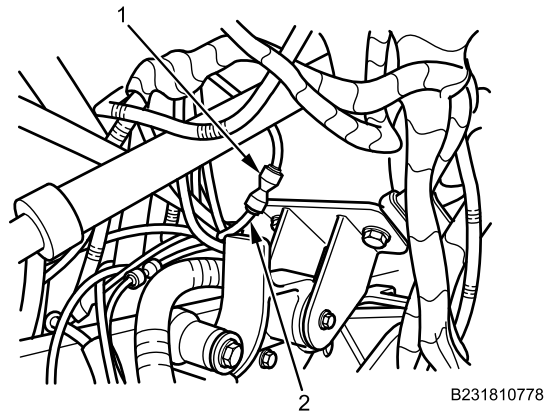
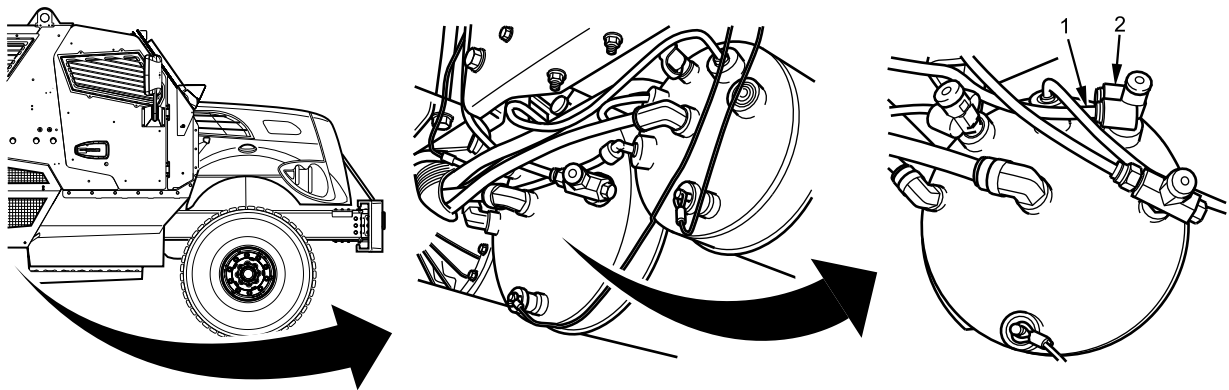

Figure 4. Primary and Supply Tanks.

4. Install new cable lock straps where noted during removal.

END OF TASK

CABIN DOOR ASSIST SYSTEM SUPPLY AIR LINE TUBING REMOVAL AND INSTALLATION - (CONTINUED)**FOLLOW-ON MAINTENANCE**

1. Install air cleaner assembly (WP 0257).
2. Turn MAIN POWER switch on (TM 9-2355-106-10).
3. Start engine (TM 9-2355-106-10).
4. Build air pressure to normal operating level (TM 9-2355-106-10).
5. Inspect for air leaks (TM 9-2355-106-10).
6. Remove wheel chocks (TM 9-2355-106-10).
7. Test-drive vehicle to verify brake system operation (TM 9-2355-106-10).
8. Set vehicle parking brake (TM 9-2355-106-10).
9. Set transmission in NEUTRAL (N) (TM 9-2355-106-10).
10. Turn engine off (TM 9-2355-106-10).
11. Turn MAIN POWER switch off (TM 9-2355-106-10).
12. Chock wheels (TM 9-2355-106-10).
13. Install left engine armor plate (WP 0597).
14. Install belly armor (WP 0606).
15. Remove wheel chocks (TM 9-2355-106-10).

END OF TASK**END OF WORK PACKAGE**

FIELD MAINTENANCE
CABIN DOOR EXTERIOR HANDLE ASSEMBLY REMOVAL AND INSTALLATION (SINGLE-AND DUAL-CYLINDER)

INITIAL SETUP:**Tools and Special Tools**

General Mechanic's Tool Kit (GMTK)
(WP 0795, Item 37)
Puller Set, mechanical (WP 0795, Item 78)
Hammer, hand, soft face, dead blow, 10 oz
(WP 0795, Item 44)
Wrench, torque, 20-100 ft-lb, 3/8-inch drive
(WP 0795, Item 141)

TM 9-2355-106-23P

WP 0786

WP 0782

Equipment Condition

Parking brake set (TM 9-2355-106-10)
Transmission set in NEUTRAL (N) (TM
9-2355-106-10)
Engine off (TM 9-2355-106-10)
MAIN POWER switch off (TM 9-2355-106-10)
Wheels chocked (TM 9-2355-106-10)
Air tanks and reservoirs drained (TM 9-2355-106-10)
Cabin door open and secured (WP 0608)
Cabin door trim panel removed (WP 0626) or
(WP 0627)

Materials/Parts

Compound (WP 0794, Item 13)
Sealing compound (WP 0794, Item 45)
Gloves, nitrile (WP 0794, Item 18)
Goggles, industrial (WP 0794, Item 20)

References

TM 9-2355-106-10

WARNING

Cabin door must be secured in the open position by using heavy duty straps to prevent accidental closure during vehicle maintenance. Pull check link retaining pin prior to securing door open. Failure to comply may result in serious injury or death to personnel.

Use the appropriate lifting sling and chain hoist for the type of load. Clean lifting strap slings and chain hoists prior to use, and inspect for damage such as wear, corrosion, elongation, tears, or punctures. Replace lifting strap slings and chain hoists that are damaged. Failure to comply may result in damage to equipment and injury or death to personnel.

NOTE

This procedure is for cabin door exterior handle with single cylinder actuator. Procedure for cabin door exterior handle with dual cylinder actuator is similar.

CABIN DOOR EXTERIOR HANDLE ASSEMBLY REMOVAL AND INSTALLATION (SINGLE-AND DUAL-CYLINDER) - (CONTINUED)**REMOVAL**

1. Remove two washers and hex bolts (Figure 1, Item 1) securing door handle shaft cover plate (Figure 1, Item 3) to inner shaft lock plate bracket (Figure 1, Item 2). Remove shaft cover plate.

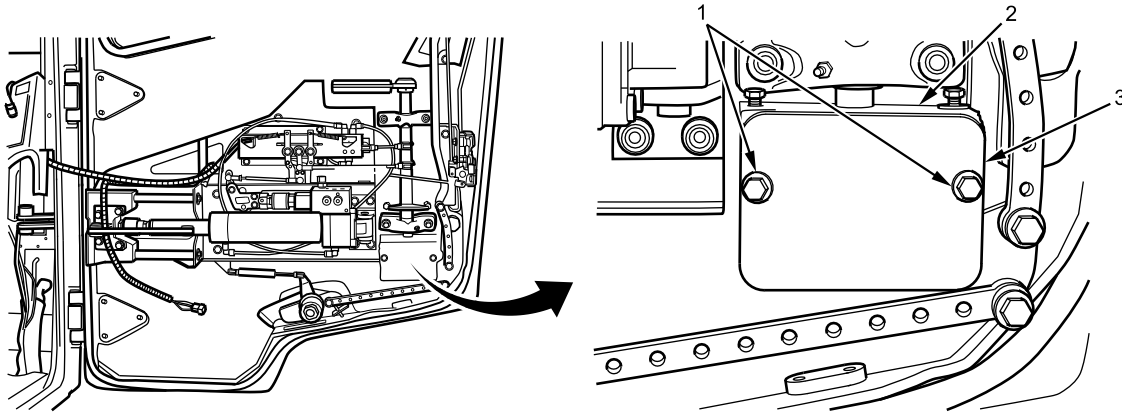

B231805367

Figure 1. Inner Door Handle Shaft Cover Plate Removal.

2. Remove two washers and hex bolts (Figure 2, Item 1) from top of inner shaft lock plate bracket (Figure 2, Item 2).

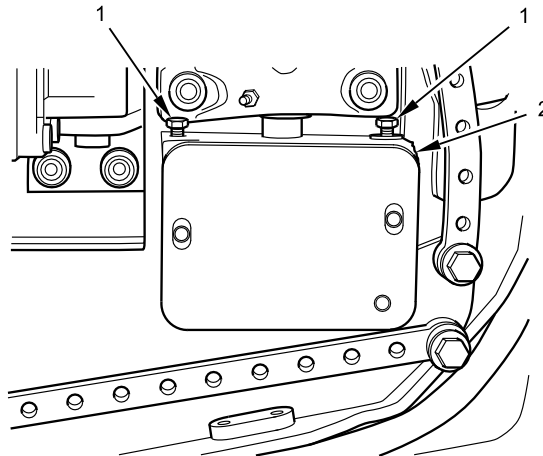

B231802154

Figure 2. Upper Hex Bolt Removal from Inner Shaft Lock Plate Bracket.

CABIN DOOR EXTERIOR HANDLE ASSEMBLY REMOVAL AND INSTALLATION (SINGLE-AND DUAL-CYLINDER) - (CONTINUED)

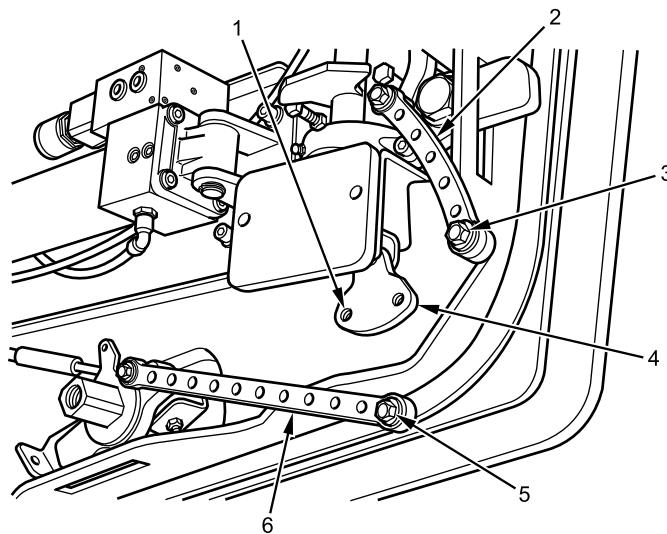

B231802156

Figure 3. Combat Lock Shaft Lever and Vertical Shaft Lever Removal from Combat Lock Bell Crank.

NOTE

Inner shaft lock plate bracket does not separate from interior handle shaft. Hex bolts and washers must be removed to gain direct access to interior handle shaft assembly and inner door component parts.

3. Remove washer and hex bolt (Figure 3, Item 3) fastening combat lock bell crank (Figure 3, Item 4) to combat lock shaft lever (Figure 3, Item 2).

NOTE

Following step 4, combat lock bell crank will remain connected to interior handle shaft assembly. Removal is not required.

4. Remove washer and hex bolt (Figure 3, Item 5) fastening combat lock bell crank (Figure 3, Item 4) to combat lock shaft lever (Figure 3, Item 6) through bell crank bolthole (Figure 3, Item 1).

CABIN DOOR EXTERIOR HANDLE ASSEMBLY REMOVAL AND INSTALLATION (SINGLE-AND DUAL-CYLINDER) - (CONTINUED)

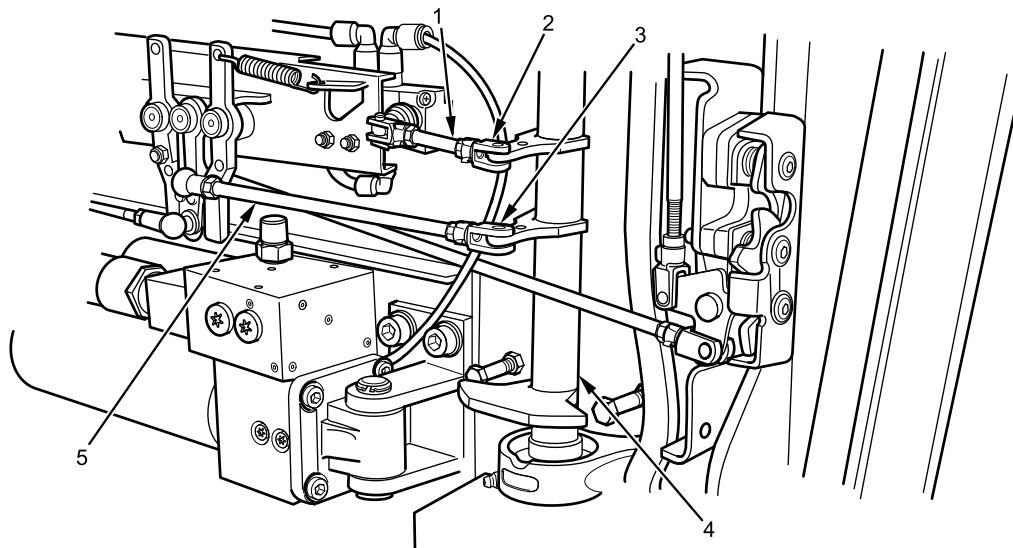

Figure 4. Retaining Clips Removal from Door Linkage Rods.

5. Remove clevis retaining clip (Figure 4, Item 2) connecting upper air valve linkage rod (Figure 4, Item 1) to door interior handle shaft (Figure 4, Item 4).

NOTE

When clevis retaining clips are removed or disconnected, linkage rods will rotate freely away from inner door to provide access to inner door components.

Ensure linkage rods are not disconnected from door latch or air valve module connectors during clevis retaining clip removal procedures.

6. Remove clevis retaining clip (Figure 4, Item 3) connecting middle linkage rod (Figure 4, Item 5) to interior door handle shaft (Figure 4, Item 4).

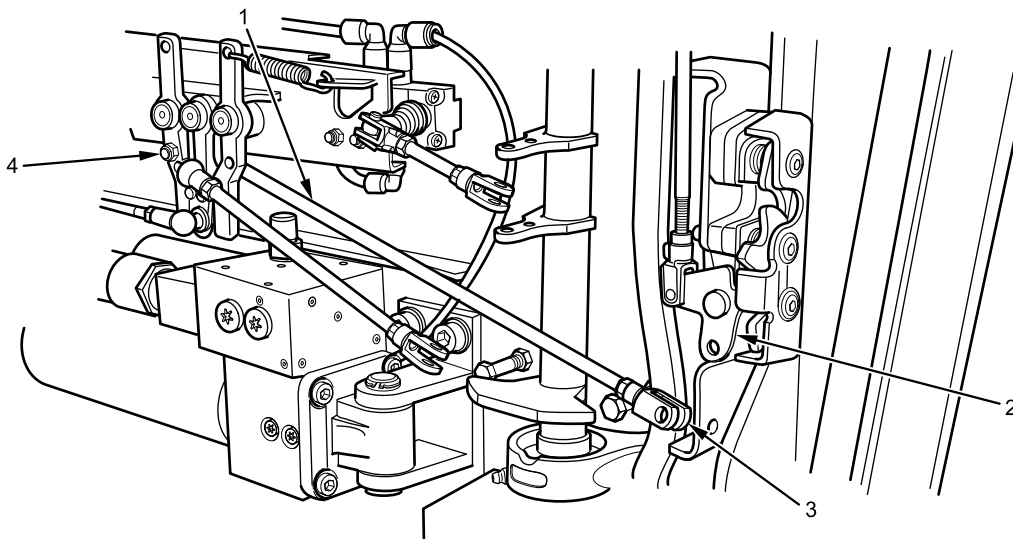
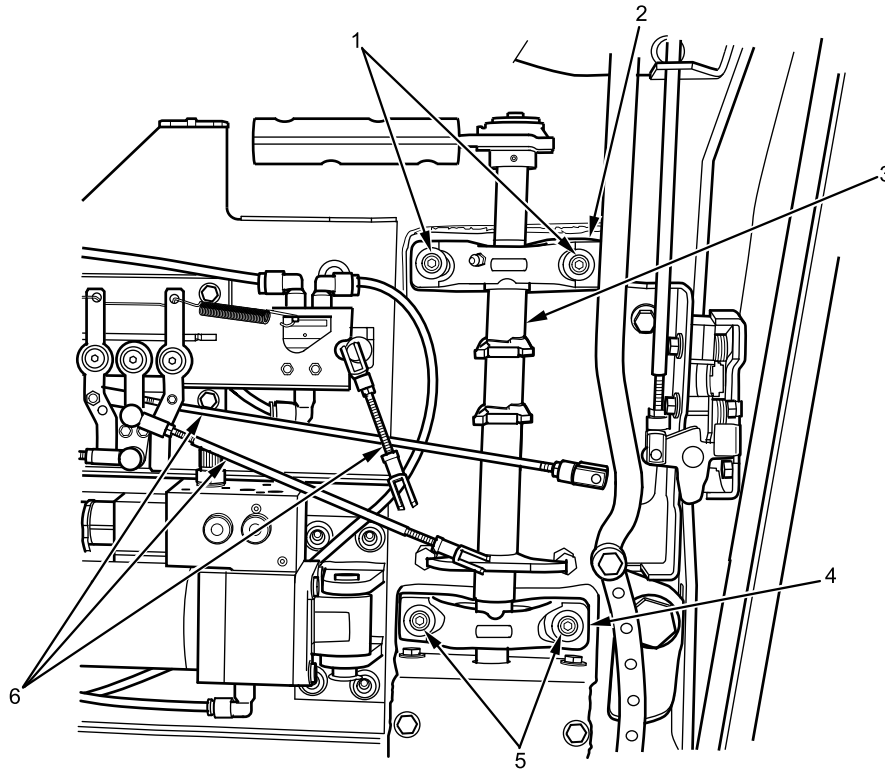

Figure 5. Retaining Clip Removed from Lower Linkage Rod and Door Latch Plate.

CABIN DOOR EXTERIOR HANDLE ASSEMBLY REMOVAL AND INSTALLATION (SINGLE-AND DUAL-CYLINDER) - (CONTINUED)

7. Remove clevis retaining clip (Figure 5, Item 3) connecting lower linkage rod (Figure 5, Item 1) to adjusting rod inner door latch plate (Figure 5, Item 2).
8. Remove lower linkage rod locknut (Figure 5, Item 4) and discard.
9. Remove lower linkage rod (Figure 5, Item 1).



B231802158

Figure 6. Interior Handle Socket Head Screws Removal.

10. Loosen, but do not remove, two upper socket head shouldered screws (Figure 6, Item 1) fastening handle shaft assembly upper bracket (Figure 6, Item 2) to inner door frame.

CAUTION

When removing door interior handle assembly, make sure linkage rods are not twisted or bent during removal procedure. Failure to comply may result in damage to equipment.

11. Carefully move three linkage rods (Figure 6, Item 6) away from interior handle shaft assembly (Figure 6, Item 3). Use minimal force when moving rods.

NOTE

Interior handle shaft assembly will remain upright and not fall down after removal of screws.

12. Remove two lower socket head shouldered screws (Figure 6, Item 5) fastening handle shaft assembly lower bracket (Figure 6, Item 4) to inner door frame.

CABIN DOOR EXTERIOR HANDLE ASSEMBLY REMOVAL AND INSTALLATION (SINGLE-AND DUAL-CYLINDER) - (CONTINUED)

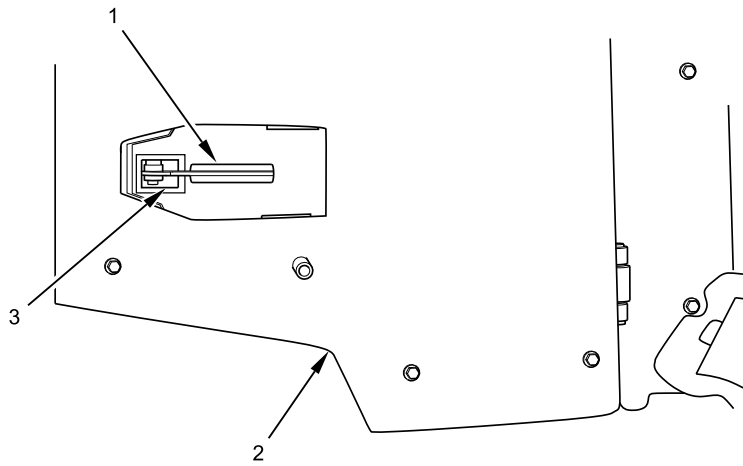

B231802427

Figure 7. Exterior Door Handle Positioned for Removal.

13. From outside vehicle cabin door (Figure 7, Item 2), push exterior door handle (Figure 7, Item 1) through outer door opening (Figure 7, Item 3) until interior handle shaft assembly is positioned 2-3 inches away from inner door frame and is ready for removal from inner door. Prior to removing exterior handle from outer door opening, do not remove washer and hex bolt from bottom of exterior door handle (Figure 7, Item 1).

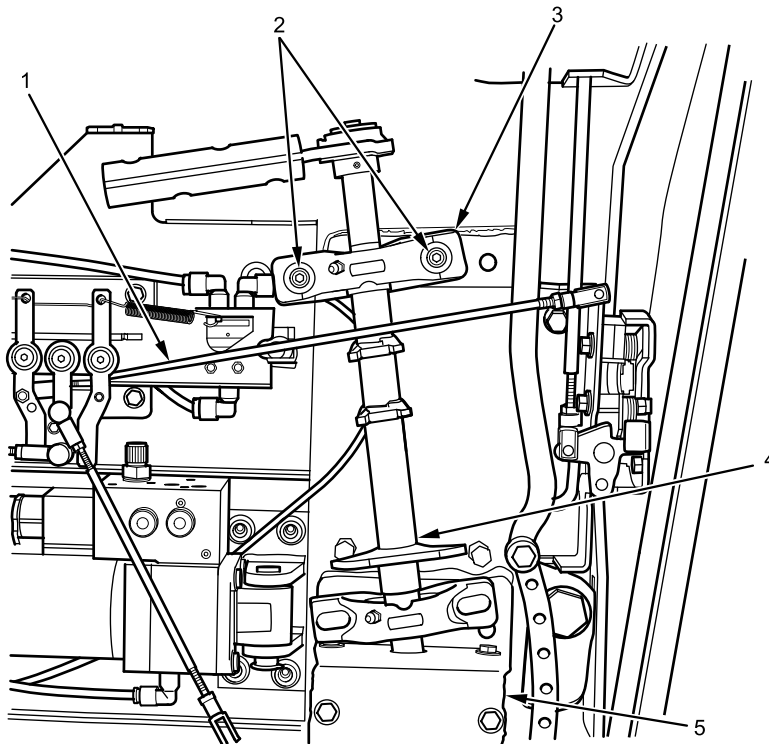

B231802159

Figure 8. Interior Door Handle Assembly Partial Removal.

CABIN DOOR EXTERIOR HANDLE ASSEMBLY REMOVAL AND INSTALLATION (SINGLE-AND DUAL-CYLINDER) - (CONTINUED)**NOTE**

Following removal of socket head shouldered screws, interior handle shaft assembly will remain in upright position, but will no longer be secured to inner door frame.

14. From inside cabin door, remove two upper socket head shouldered screws (Figure 8, Item 2) fastening upper door handle shaft bracket (Figure 8, Item 3) to inner door frame.
15. Tilt interior handle shaft assembly (Figure 8, Item 4) to left side for ease in removal.
16. Move lower linkage rod (Figure 8, Item 1) upwards to permit removal of handle shaft assembly (Figure 8, Item 4). During removal, exterior door handle, bell crank, and inner shaft lock plate bracket (Figure 8, Item 5) will remain attached to handle shaft assembly.
17. Carefully lift and remove door interior handle assembly, bell crank, lock plate bracket, and exterior door handle from inner door mounting locations (Figure 9, Item 1 and 2).

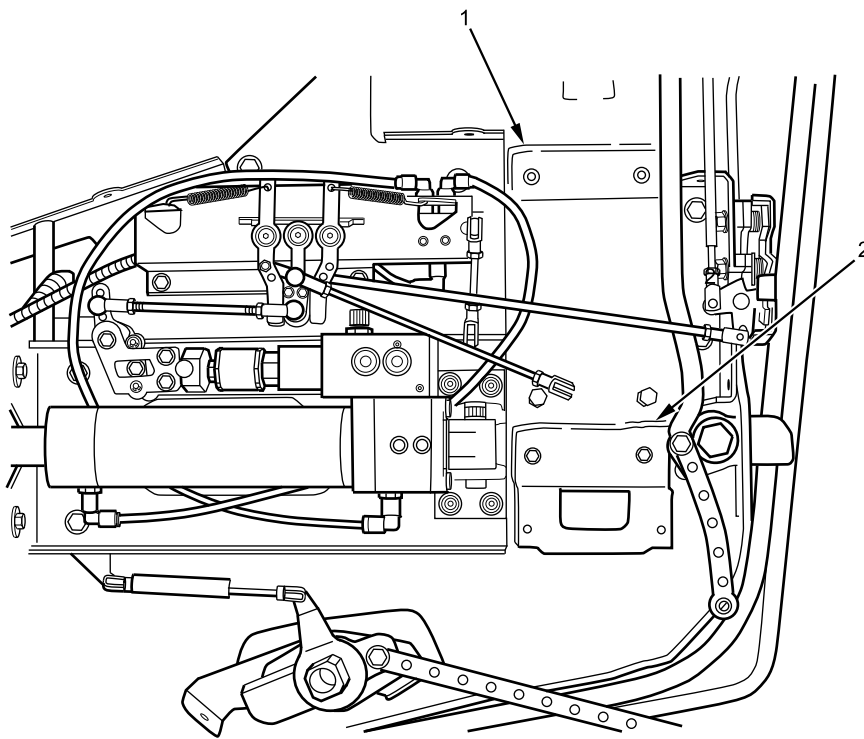

B231802160

Figure 9. Cabin Door Interior Handle Assembly Removal from Inner Door.

18. Place door interior handle assembly and exterior door handle on bench or suitable work area.

CABIN DOOR EXTERIOR HANDLE ASSEMBLY REMOVAL AND INSTALLATION (SINGLE-AND DUAL-CYLINDER) - (CONTINUED)

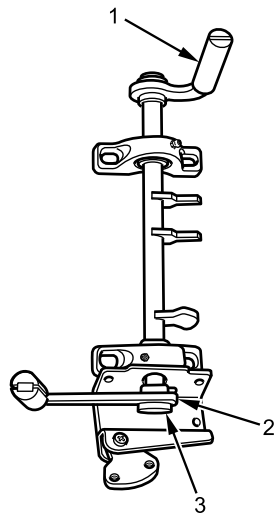

B231802161

Figure 10. Cabin Door Interior Handle Assembly.

NOTE

Exterior handle and interior handle shaft assembly may remain tightly fastened together following removal of washer and hex bolt.

19. Remove washer and door handle hex bolt (Figure 10, Item 3) fastening exterior handle (Figure 10, Item 2) to interior handle shaft assembly (Figure 10, Item 1).
20. Position interior handle shaft assembly (Figure 11, Item 4) face down on bench or work area with exposed exterior handle (Figure 11, Item 2) and setscrew (Figure 11, Item 3) located above surface of inner shaft lock plate bracket (Figure 11, Item 1).

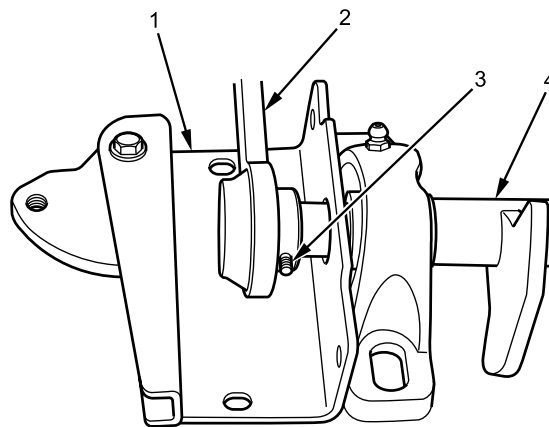

B231802162

Figure 11. Setscrew Loosened on Exterior Handle.

21. Loosen, but do not remove, setscrew (Figure 11, Item 3).

CABIN DOOR EXTERIOR HANDLE ASSEMBLY REMOVAL AND INSTALLATION (SINGLE-AND DUAL-CYLINDER) - (CONTINUED)

22. Using mechanical puller, remove exterior door handle (Figure 12, Item 1) from interior handle shaft assembly.

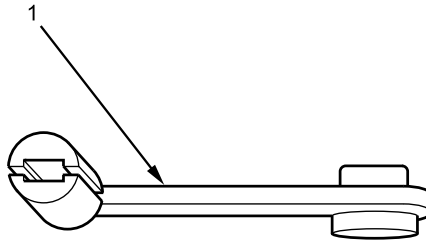

B231802439

Figure 12. Exterior Handle Removed from Interior Handle Assembly.

END OF TASK

CABIN DOOR EXTERIOR HANDLE ASSEMBLY REMOVAL AND INSTALLATION (SINGLE-AND DUAL-CYLINDER) - (CONTINUED)

INSTALLATION

WARNING

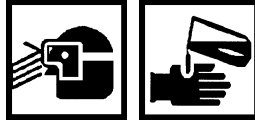

Thread sealing compound is harmful to skin and eyes. If thread sealing compound contacts eyes, rinse thoroughly and contact physician if irritation persists. If skin is contacted, wash thoroughly with soap and water. Failure to comply may result in serious injury to personnel.

1. Clean sealing compound from inner shaft lock plate bracket (Figure 13, Item 1) and inside door frame mounting location.

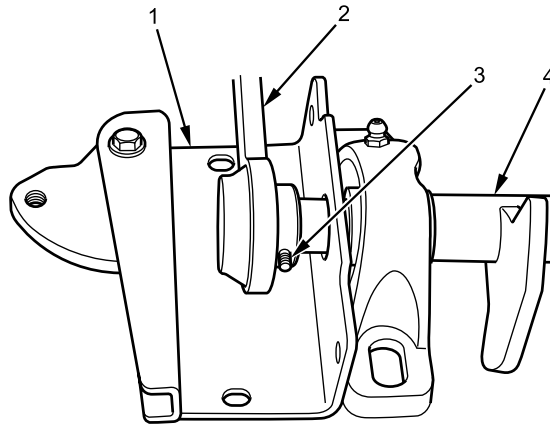

B231802162

Figure 13. Exterior Handle Installation on Interior Handle Shaft Assembly.

2. Insert interior handle shaft assembly (Figure 13, Item 4) through hole of inner shaft lock plate bracket (Figure 13, Item 1).
3. Lubricate exterior handle end of interior handle shaft (Figure 13, Item 4).
4. Align exterior handle (Figure 13, Item 2) with lower end of interior handle shaft assembly (Figure 13, Item 4), and use soft face hammer to install exterior handle on lower shaft of interior handle assembly.
5. When exterior handle (Figure 13, Item 2) is tightly fastened to interior handle shaft assembly (Figure 13, Item 4), tighten setscrew (Figure 13, Item 3) securely.
6. Fasten door exterior handle (Figure 14, Item 2) to interior handle shaft assembly (Figure 14, Item 1) with washer and hex bolt (Figure 14, Item 3). Tighten hex bolt securely.

CABIN DOOR EXTERIOR HANDLE ASSEMBLY REMOVAL AND INSTALLATION (SINGLE-AND DUAL-CYLINDER) - (CONTINUED)

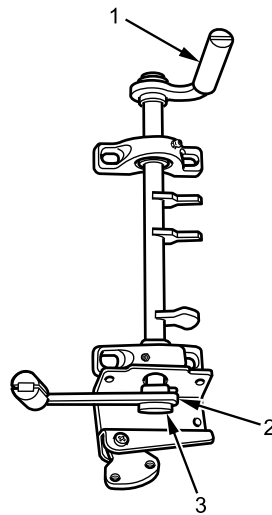

B231802161

Figure 14. Interior Handle Shaft Assembly Installation on Inner Door Frame.

7. From inside cabin door, move three door adjusting rods away from inner door frame.
8. Insert cabin door interior handle shaft assembly (Figure 14, Item 1) behind door adjusting rods.
9. Align two interior handle shaft assembly brackets with two mounting locations on inside door frame.
10. During interior handle shaft assembly bracket mounting procedure, insert new exterior door handle (Figure 15, Item 1) through lower handle opening (Figure 15, Item 3) inside vehicle door (Figure 15, Item 2). Exterior door handle will slide through inner door frame to a location on outside door handle frame.

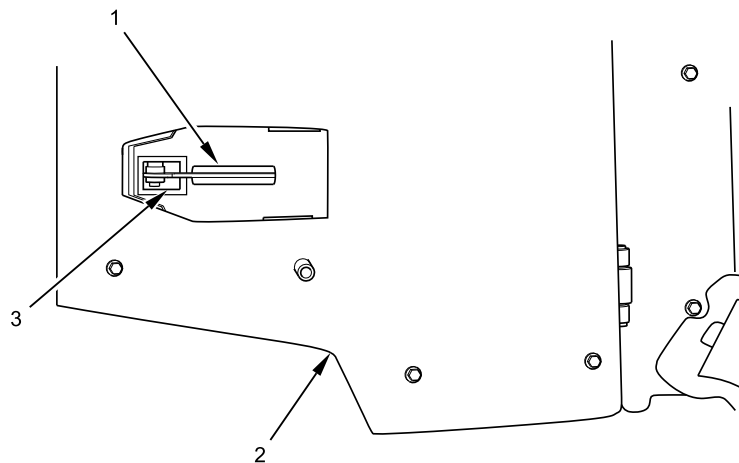

B231802427

Figure 15. New Door Exterior Handle Installation.

11. Apply thread sealing compound to four washers and four socket head shouldered screws.

CABIN DOOR EXTERIOR HANDLE ASSEMBLY REMOVAL AND INSTALLATION (SINGLE-AND DUAL-CYLINDER) - (CONTINUED)

12. Position lower linkage rod (Figure 16, Item 1) to door lock (Figure 16, Item 4) and door lock lever (Figure 16, Item 8).

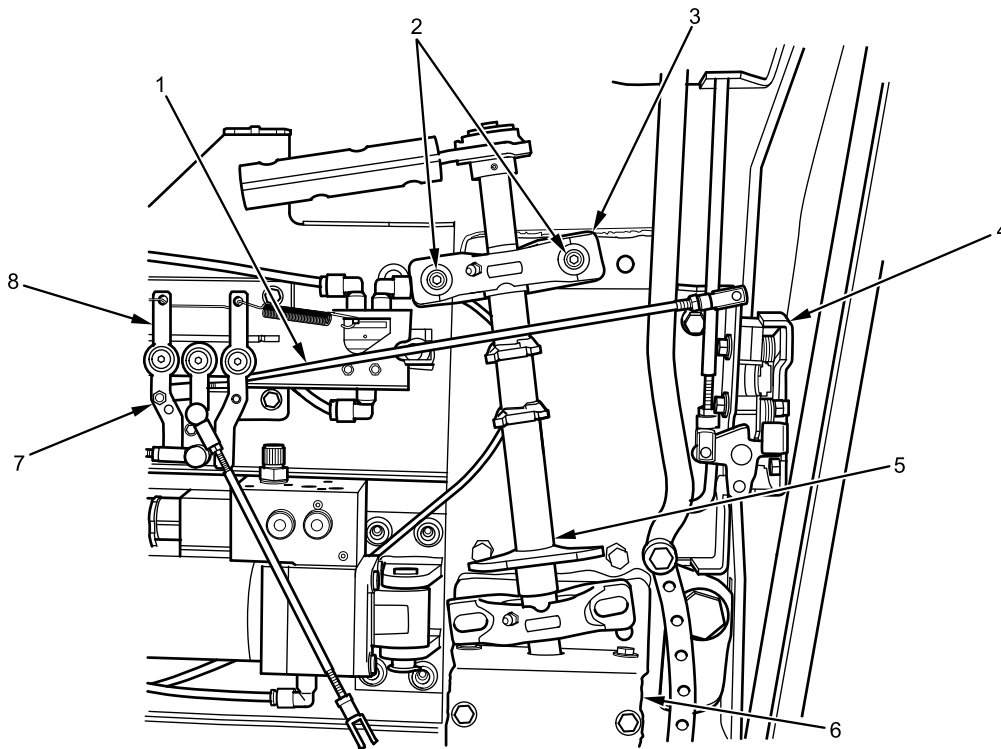

B231804669

Figure 16. Door Interior Handle Shaft Assembly Partial Installation.

13. Install new locknut (Figure 16, Item 7).
14. Position inner shaft lock plate bracket (Figure 16, Item 6) at mounting location on lower door frame.
15. Position handle shaft upper bracket (Figure 16, Item 3) adjacent to mounting area on vehicle door frame.
16. Loosely install two washers and socket head shouldered screws (Figure 16, Item 2) in upper handle shaft assembly bracket (Figure 16, Item 3), fastening interior handle shaft assembly (Figure 16, Item 5) to vehicle inner door frame. Do not tighten screws.
17. Pull three linkage rods (Figure 17, Item 6) away from inner door for ease of installation.

CABIN DOOR EXTERIOR HANDLE ASSEMBLY REMOVAL AND INSTALLATION (SINGLE-AND DUAL-CYLINDER) - (CONTINUED)

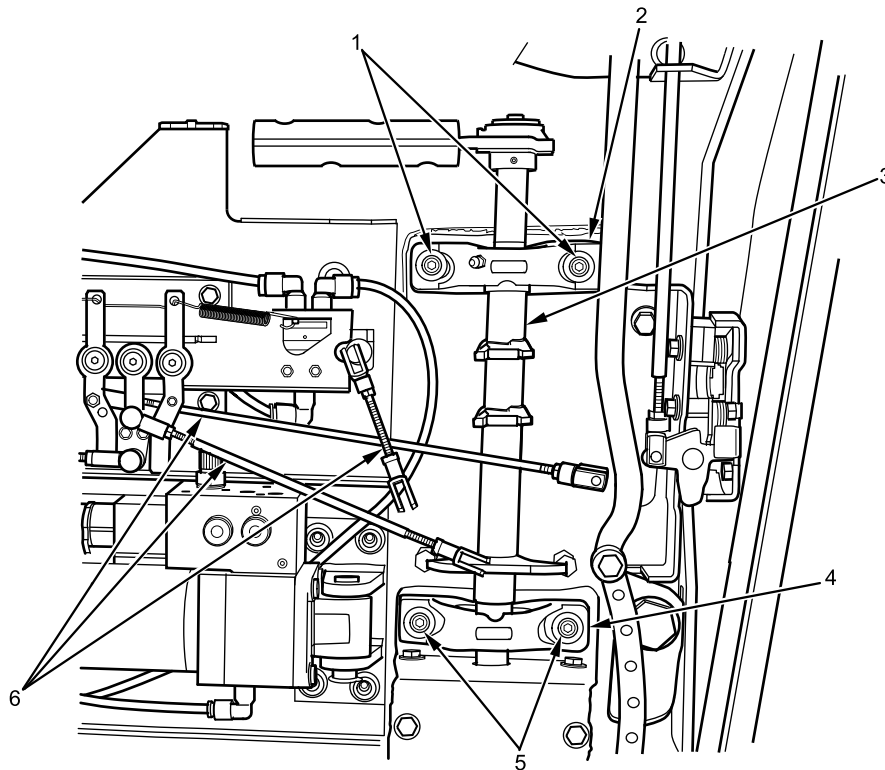

B231802158

Figure 17. Door Interior Handle Assembly Secured to Inner Door.

18. Install lower interior handle shaft assembly (Figure 17, Item 3) and lower shaft bracket (Figure 17, Item 4) on vehicle inner door frame with two washers and two socket head shouldered screws (Figure 17, Item 5).
19. Torque four screws (Figure 17, Item 1 and 5) securing two brackets (Figure 17, Item 2 and 4) and handle shaft assembly (Figure 17, Item 3) to 17 lb-ft (23 N•m).

CABIN DOOR EXTERIOR HANDLE ASSEMBLY REMOVAL AND INSTALLATION (SINGLE-AND DUAL-CYLINDER) - (CONTINUED)

20. Connect upper linkage rod (Figure 18, Item 1) to upper bracket on interior handle shaft assembly (Figure 18, Item 4) with clevis retaining clip (Figure 18, Item 2).

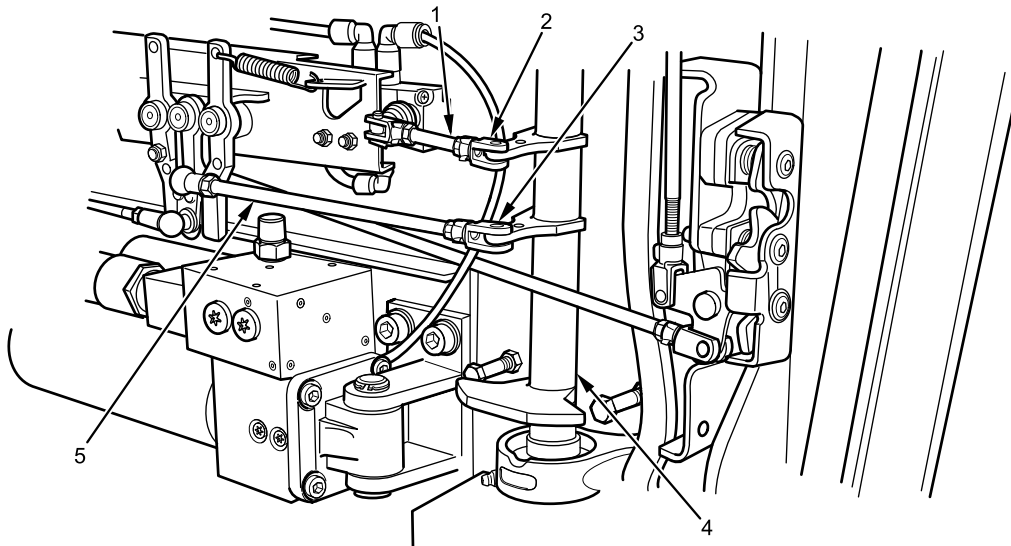

B231802157

Figure 18. Retaining Clips Installed on Linkage Rods.

21. Connect middle linkage rod (Figure 18, Item 5) to middle bracket on interior handle shaft assembly (Figure 18, Item 4) with clevis retaining clip (Figure 18, Item 3).
22. Connect lower linkage rod to adjusting rod inner door latch plate with clevis retaining clip.
23. Install combat lock shaft lever (Figure 19, Item 6) in combat lock bell crank bolthole (Figure 19, Item 1) with washer and hex bolt (Figure 19, Item 5). Tighten bolt securely.

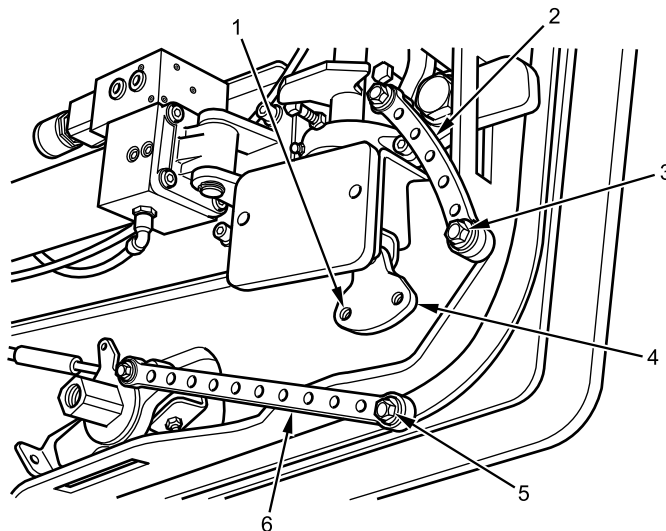

B231802156

Figure 19. Combat Shaft Lever and Vertical Lever Installed on Bell Crank.

24. Install lock shaft lever (Figure 19, Item 2) on combat lock bell crank (Figure 19, Item 4) with washer and hex bolt (Figure 19, Item 3). Tighten bolt securely.
25. Test cabin door manually and verify exterior door handle latch operation. Adjust as required if door fails to latch, or if handle does not work properly.

CABIN DOOR EXTERIOR HANDLE ASSEMBLY REMOVAL AND INSTALLATION (SINGLE-AND DUAL-CYLINDER) - (CONTINUED)

26. Apply sealing compound to inner shaft lock plate bracket (Figure 20, Item 2).

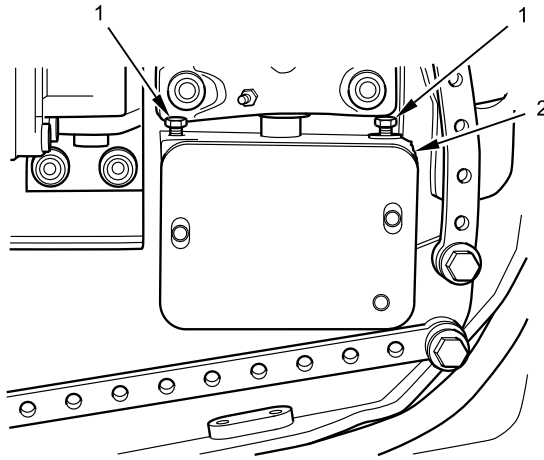

B231802154

Figure 20. Hex Bolts Installed on Inner Shaft Lock Plate Bracket.

27. Install inner shaft lock plate bracket (Figure 20, Item 2) on interior handle shaft assembly bracket with two washers and hex bolts (Figure 20, Item 1). Tighten bolts securely.
28. Install door handle shaft cover plate (Figure 21, Item 3) on inner shaft lock plate bracket (Figure 21, Item 2) with two washers and hex bolts (Figure 21, Item 1). Tighten bolts securely.

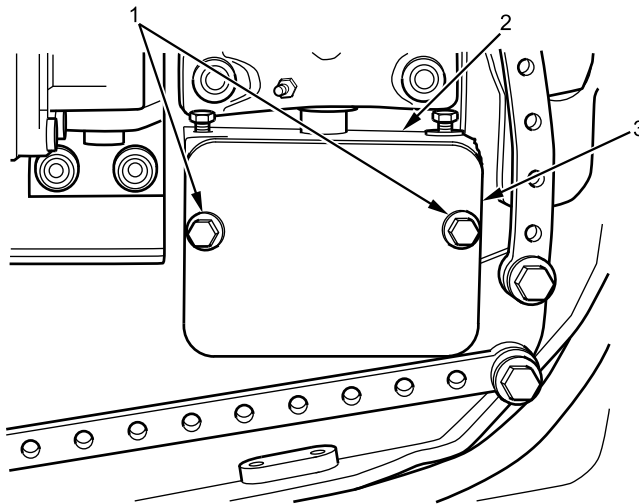

B231802153

Figure 21. Inner Door Handle Shaft Cover Plate Installation.

END OF TASK

CABIN DOOR EXTERIOR HANDLE ASSEMBLY REMOVAL AND INSTALLATION (SINGLE-AND DUAL-CYLINDER) - (CONTINUED)**FOLLOW-ON MAINTENANCE**

1. Turn battery power switch on (TM 9-2355-106-10).
2. Start engine (TM 9-2355-106-10).
3. Refill air tanks (TM 9-2355-106-10).
4. Remove cabin door securing chain hoist and lifting strap (WP 0608).
5. Verify exterior and interior door handle assemblies, inner cabin door latch assembly, and exterior door latch for proper operation. Adjust as required if door fails to latch, or if any handle does not work properly.
6. Turn engine off (TM 9-2355-106-10).
7. Turn MAIN POWER switch off (TM 9-2355-106-10).
8. Remove wheel chocks (TM 9-2355-106-10).

END OF TASK**END OF WORK PACKAGE**

FIELD MAINTENANCE
CABIN DOOR INTERIOR HANDLE ASSEMBLY REMOVAL AND INSTALLATION (SINGLE-PISTON, LOWER COMBAT DOOR LOCK-TYPE)

INITIAL SETUP:**Tools and Special Tools**

General Mechanic's Tool Kit (GMTK)
(WP 0795, Item 37)
Hammer, hand, soft face, dead blow, 10 oz
(WP 0795, Item 44)
Puller set, mechanical (WP 0795, Item 78)
Socket driver, 3/8 inch drive, 6 mm Allen head
(WP 0795, Item 94)
Wrench, torque, 20-100 lb-ft, 3/8-inch drive
(WP 0795, Item 141)

Materials/Parts

Sealing compound (WP 0794, Item 45)
Sealing compound (WP 0794, Item 43)

References

TM 9-2355-106-10

TM 9-2355-106-23P

WP 0782

Equipment Condition

Parking brake set (TM 9-2355-106-10)
Transmission set in NEUTRAL (N) (TM 9-2355-106-10)
Engine off (TM 9-2355-106-10)
MAIN POWER switch off (TM 9-2355-106-10)
Wheels chocked (TM 9-2355-106-10)
Air tanks and reservoirs drained (TM 9-2355-106-10)
Cabin door open and secured (WP 0608)
Cabin door trim panel removed (WP 0626)

WARNING

Do not operate vehicle with air pressure system loss. Vehicle has reduced or no braking capability and may not stop. Failure to comply may result in damage to equipment and serious injury or death to personnel.

Let air pressure build in both tanks to 100 psi (689 kPa) before releasing the parking brake. Low air pressure may affect vehicle braking capability. Failure to comply may result in injury or death to personnel.

Cabin door must be secured in the open position by using heavy duty winch straps to prevent accidental closure during vehicle maintenance. Pull door hinge pin prior to securing door open. Failure to comply may result in serious injury or death to personnel.

Use the appropriate lifting strap sling or chain hoist for the type of load. Always clean and inspect lifting strap slings and chain hoists prior to use. Inspect for damage such as wear, corrosion, elongation, tears, or punctures. Replace lifting strap slings or chain hoists that are damaged. Failure to comply may result in component damage and death or injury to personnel.

CABIN DOOR INTERIOR HANDLE ASSEMBLY REMOVAL AND INSTALLATION (SINGLE-PISTON, LOWER COMBAT DOOR LOCK-TYPE) - (CONTINUED)**NOTE**

Cabin door interior handle assembly removal and installation work package instructions should be discussed prior to starting the task to ensure instructions are understood by all participants. Mark and label all connections and reference areas before removal of component parts.

Removal of quick release pin will permit cabin door to be opened wider to provide greater access to inner door component parts.

Right door shown, left door same.

Note orientation of cabin door inner combat lock latch handle for later installation. Right door shown, left similar.

REMOVAL

1. Remove two hex bolts and washers (Figure 1, Item 1) securing door handle shaft cover plate (Figure 1, Item 3) to inner shaft lockplate bracket (Figure 1, Item 2). Remove shaft cover plate.

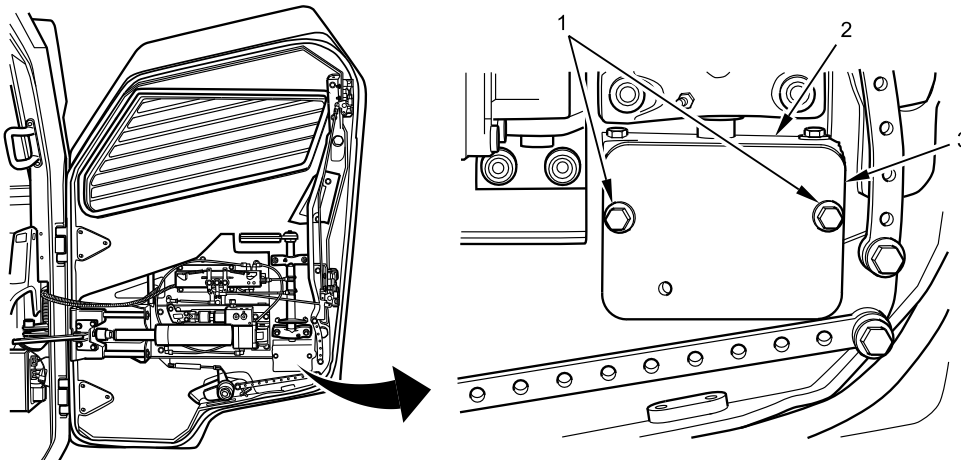

B231805284

Figure 1. Inner Door Handle Shaft Cover Plate.

2. Remove two hex bolts (Figure 2, Item 1) and washers from top of inner shaft lockplate bracket (Figure 2, Item 2).

CABIN DOOR INTERIOR HANDLE ASSEMBLY REMOVAL AND INSTALLATION (SINGLE-PISTON, LOWER COMBAT DOOR LOCK-TYPE) - (CONTINUED)

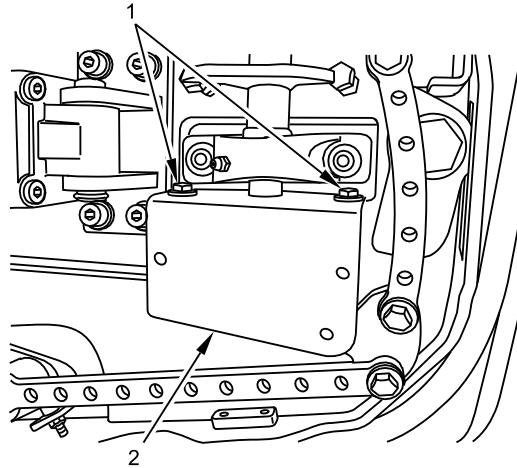

B231810875

Figure 2. Upper Hex Bolt.

NOTE

Inner shaft lockplate bracket does not separate from interior handle shaft. Hex bolts and washers must be removed to gain direct access to interior handle shaft assembly and inner door component parts.

3. Remove hex bolt (Figure 3, Item 3) and washer fastening vertical shaft lever (Figure 3, Item 2) to combat lock bellcrank (Figure 3, Item 4).

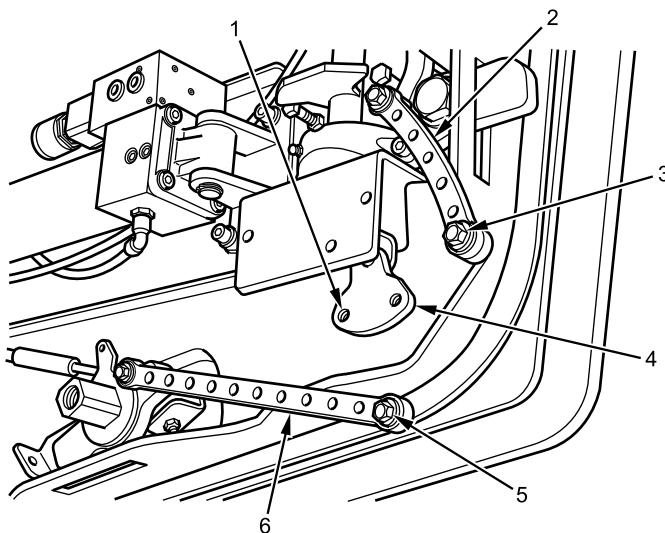

B231804699

Figure 3. Combat Lock Shaft Lever and Vertical Shaft Lever.

4. Remove hex bolt (Figure 3, Item 5) and washer fastening combat lock shaft lever (Figure 3, Item 6) to combat lock bellcrank (Figure 3, Item 4) through bellcrank bolthole (Figure 3, Item 1).

CABIN DOOR INTERIOR HANDLE ASSEMBLY REMOVAL AND INSTALLATION (SINGLE-PISTON, LOWER COMBAT DOOR LOCK-TYPE) - (CONTINUED)

WARNING

When clevis retaining clips are removed or disconnected, linkage rods will rotate freely away from inner door to provide access to inner door components.

Ensure linkage rods are not disconnected from door latch or air valve module connectors during clevis retaining clip removal procedures.

5. Remove clevis retaining clip (Figure 4, Item 2) connecting upper linkage rod (Figure 4, Item 1) to cabin door interior handle assembly (Figure 4, Item 7).

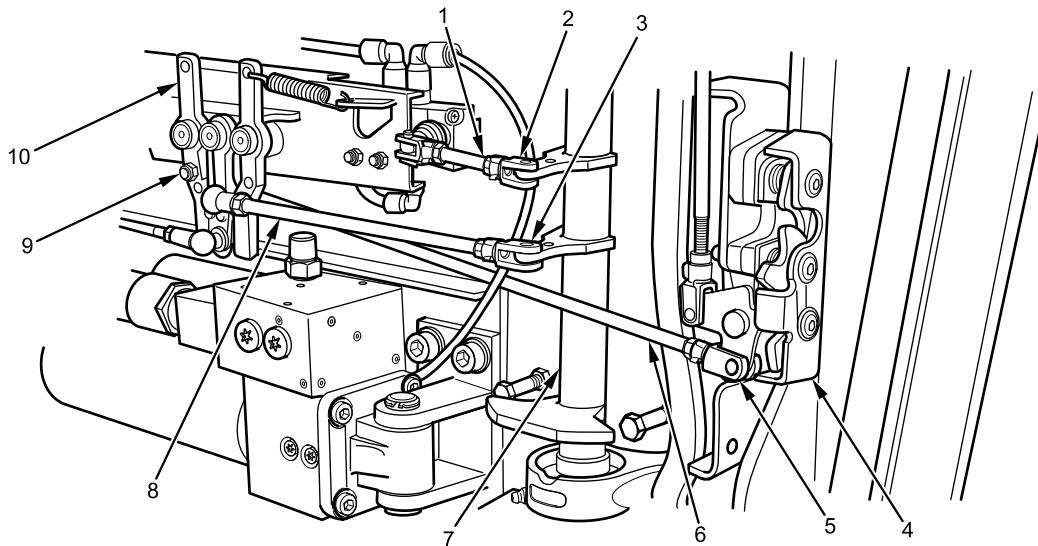

B231804744

Figure 4. Retaining Clips and Door Linkage Rods.

6. Remove clevis retaining clip (Figure 4, Item 3) connecting middle linkage rod (Figure 4, Item 8) to cabin door interior handle assembly (Figure 4, Item 7).
7. Remove clevis retaining clip (Figure 4, Item 5), nut (Figure 4, Item 9) and lower linkage rod (Figure 4, Item 6) from lock mechanism assembly (Figure 4, Item 4) and lock handle (Figure 4, Item 10).

CABIN DOOR INTERIOR HANDLE ASSEMBLY REMOVAL AND INSTALLATION (SINGLE-PISTON, LOWER COMBAT DOOR LOCK-TYPE) - (CONTINUED)

8. Loosen, but do not remove, two upper socket-head shouldered screws (Figure 5, Item 1) fastening upper bearing block (Figure 5, Item 2) to inner door frame.

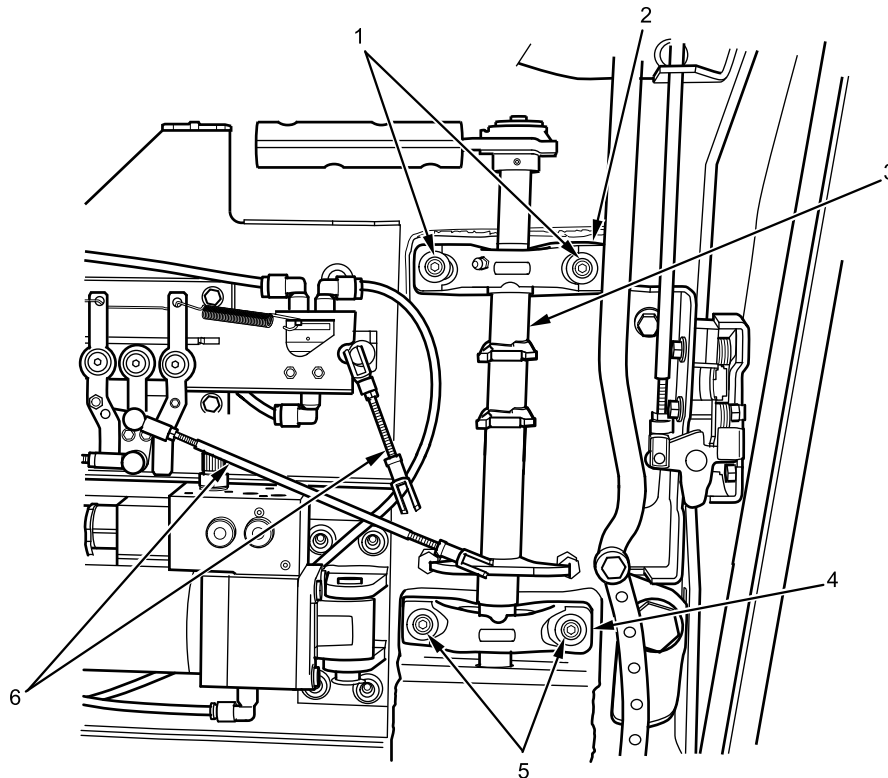

B231804745

Figure 5. Cabin Door Interior Handle Socket-Head Screws.

CAUTION

When removing cabin door interior handle assembly, make sure linkage rods are not twisted or bent during removal procedure. Failure to comply may result in damage to equipment.

9. Carefully position two linkage rods (Figure 5, Item 6) away from cabin door interior handle assembly (Figure 5, Item 3). Use minimal force when moving rods.

NOTE

Cabin door interior handle assembly will remain upright and not fall down after removal of screws and washers.

10. Remove two lower socket-head shouldered screws (Figure 5, Item 5) and washers fastening lower bearing block (Figure 5, Item 4) to inner door frame.

CABIN DOOR INTERIOR HANDLE ASSEMBLY REMOVAL AND INSTALLATION (SINGLE-PISTON, LOWER COMBAT DOOR LOCK-TYPE) - (CONTINUED)**NOTE**

Following removal of socket-head shouldered screws and washers, cabin door interior handle assembly will remain in upright position, but will no longer be secured to inner door frame.

11. From inside cabin door, support cabin door interior handle assembly (Figure 6, Item 3), remove two upper socket-head shouldered screws (Figure 6, Item 1) and washers fastening upper bearing block (Figure 6, Item 2) to inner door frame.

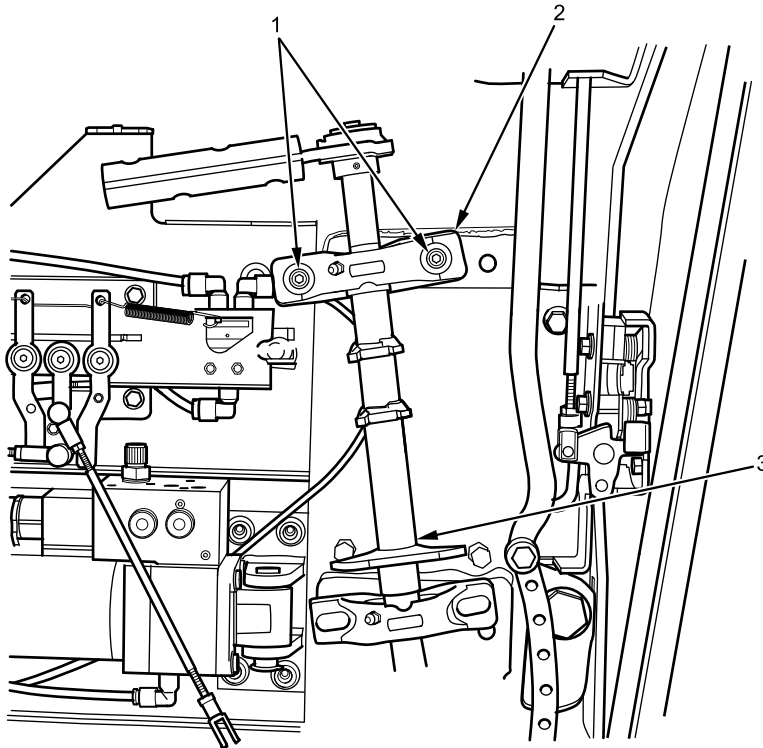

B231804746

Figure 6. Cabin Door Interior Handle Assembly.

12. Carefully remove cabin door interior handle assembly (Figure 6, Item 3) from door.

END OF TASK

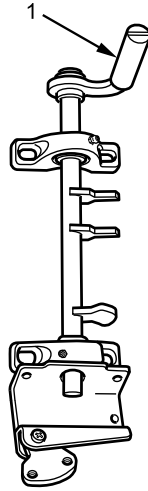
CABIN DOOR INTERIOR HANDLE ASSEMBLY REMOVAL AND INSTALLATION (SINGLE-PISTON, LOWER COMBAT DOOR LOCK-TYPE) - (CONTINUED)**DISASSEMBLY**

B231802438

Figure 7. Cabin Door Interior Handle Assembly.

1. Place cabin door interior handle assembly (Figure 7, Item 1) on bench or suitable work area.

CABIN DOOR INTERIOR HANDLE ASSEMBLY REMOVAL AND INSTALLATION (SINGLE-PISTON, LOWER COMBAT DOOR LOCK-TYPE) - (CONTINUED)

2. Remove bolt (Figure 8, Item 10) and washer (Figure 8, Item 9) retaining exterior door handle (Figure 8, Item 11) to shaft assembly (Figure 8, Item 17).

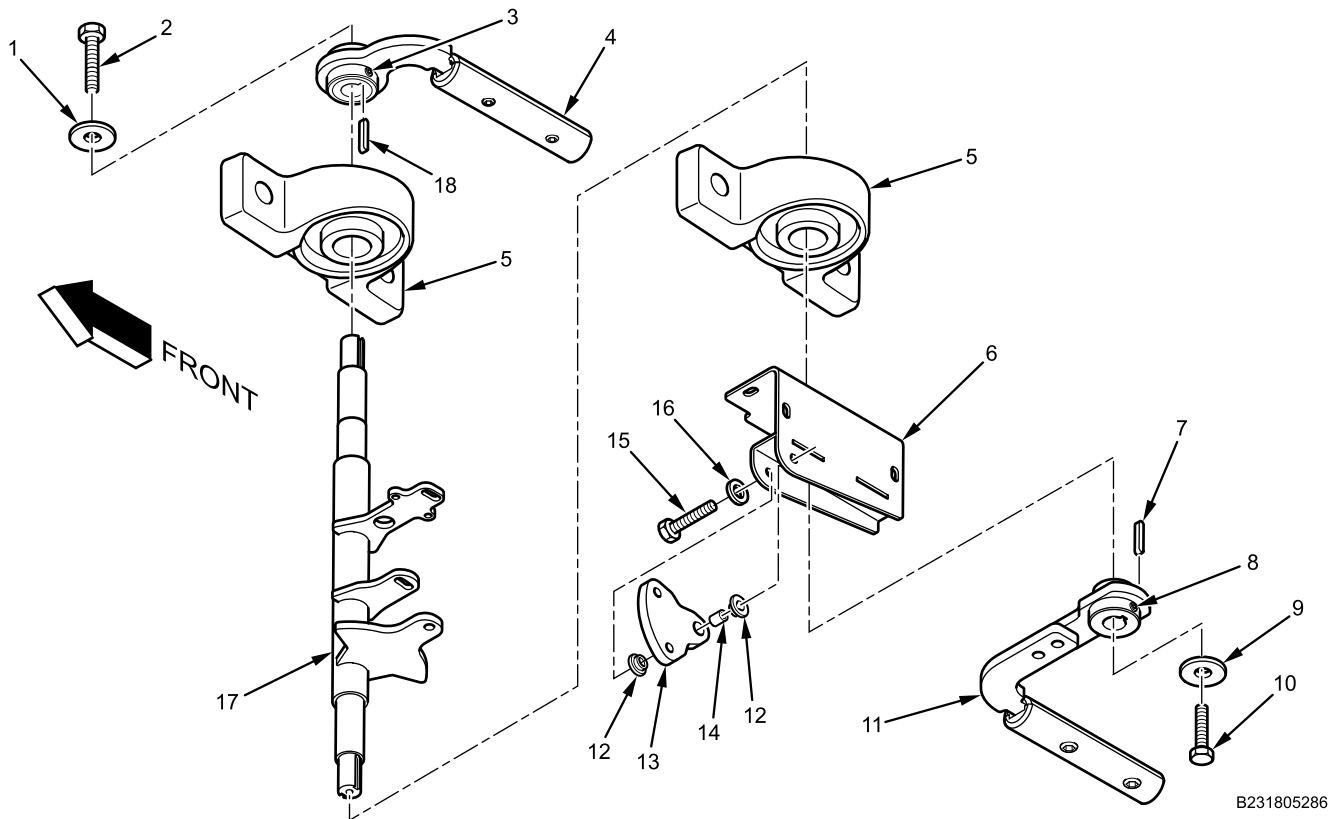

Figure 8. Cabin Door Interior Handle.

3. Loosen setscrew (Figure 8, Item 8) in exterior door handle (Figure 8, Item 11).
4. Using mechanical puller, remove exterior door handle (Figure 8, Item 11) and key (Figure 8, Item 7) from shaft assembly (Figure 8, Item 17).
5. Remove bolt (Figure 8, Item 2) and washer (Figure 8, Item 1) retaining interior door handle (Figure 8, Item 4) to shaft assembly (Figure 8, Item 17).
6. Loosen setscrew (Figure 8, Item 3) in interior door handle (Figure 8, Item 4).
7. Using mechanical puller, remove interior door handle (Figure 8, Item 4) and key (Figure 8, Item 18) from shaft assembly (Figure 8, Item 17).
8. Remove bolt (Figure 8, Item 15), washer (Figure 8, Item 16), bearings (Figure 8, Item 12), crank spacer (Figure 8, Item 14), and crank (Figure 8, Item 13) from bracket (Figure 8, Item 6).
9. Remove inner shaft plate bracket (Figure 8, Item 6) from shaft assembly (Figure 8, Item 17).
10. Using mechanical puller, remove two bearing blocks (Figure 8, Item 5) from shaft assembly (Figure 8, Item 17).
11. Clean residual sealing compound from mating surface of inner shaft plate bracket (Figure 8, Item 6).

END OF TASK

CABIN DOOR INTERIOR HANDLE ASSEMBLY REMOVAL AND INSTALLATION (SINGLE-PISTON, LOWER COMBAT DOOR LOCK-TYPE) - (CONTINUED)

ASSEMBLY

- Using soft face hammer, install two bearing blocks (Figure 9, Item 5) on shaft assembly (Figure 9, Item 17).

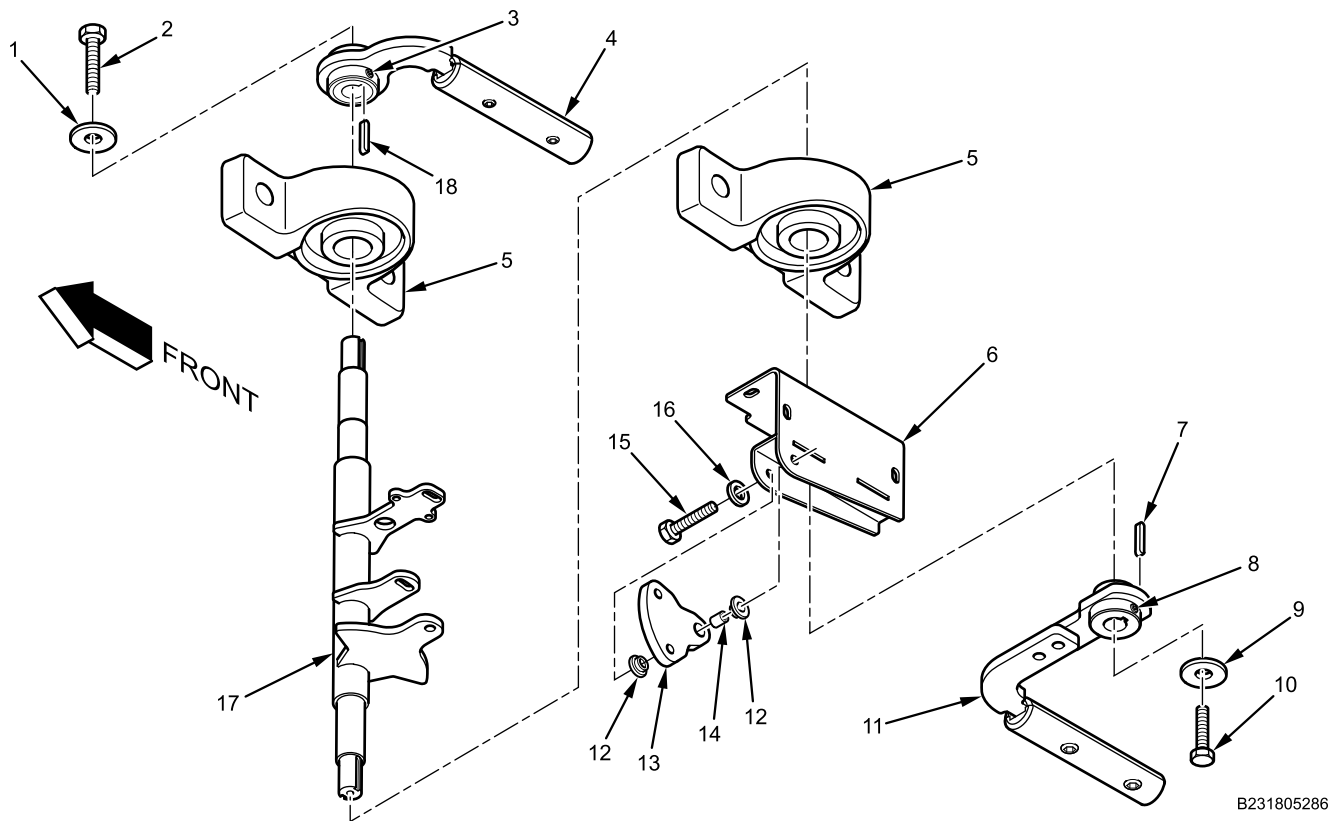

Figure 9. Cabin Door Interior Handle.

- Install bracket (Figure 9, Item 6) on shaft assembly (Figure 9, Item 17).
- Install crank (Figure 9, Item 13), crank spacer (Figure 9, Item 14), and bearings (Figure 9, Item 12) on bracket (Figure 9, Item 6) with bolt (Figure 9, Item 15) and washer (Figure 9, Item 16). Tighten bolt securely.
- Using a soft face hammer, install interior door handle (Figure 9, Item 4) and key (Figure 9, Item 18) on shaft assembly (Figure 9, Item 17).
- Tighten setscrew (Figure 9, Item 3) on interior door handle (Figure 9, Item 4) securely.
- Install bolt (Figure 9, Item 2) and washer (Figure 9, Item 1) securing interior door handle (Figure 9, Item 4) to shaft assembly (Figure 9, Item 17). Tighten bolt securely.
- Using a soft face hammer, install exterior door handle (Figure 9, Item 11) and key (Figure 9, Item 7) on shaft assembly (Figure 9, Item 17).
- Tighten setscrew (Figure 9, Item 8) on exterior door handle (Figure 9, Item 11) securely.
- Install bolt (Figure 9, Item 10) and washer (Figure 9, Item 9) securing exterior door handle (Figure 9, Item 11) to shaft assembly (Figure 9, Item 17). Tighten bolt securely.

END OF TASK

CABIN DOOR INTERIOR HANDLE ASSEMBLY REMOVAL AND INSTALLATION (SINGLE-PISTON, LOWER COMBAT DOOR LOCK-TYPE) - (CONTINUED)

INSTALLATION

WARNING

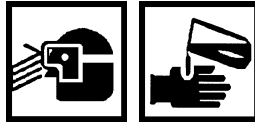

Thread sealing compound is harmful to skin and eyes. If thread sealing compound contacts eyes, rinse thoroughly and contact physician if irritation persists. If skin is contacted, wash thoroughly with soap and water. Failure to comply may result in serious injury to personnel.

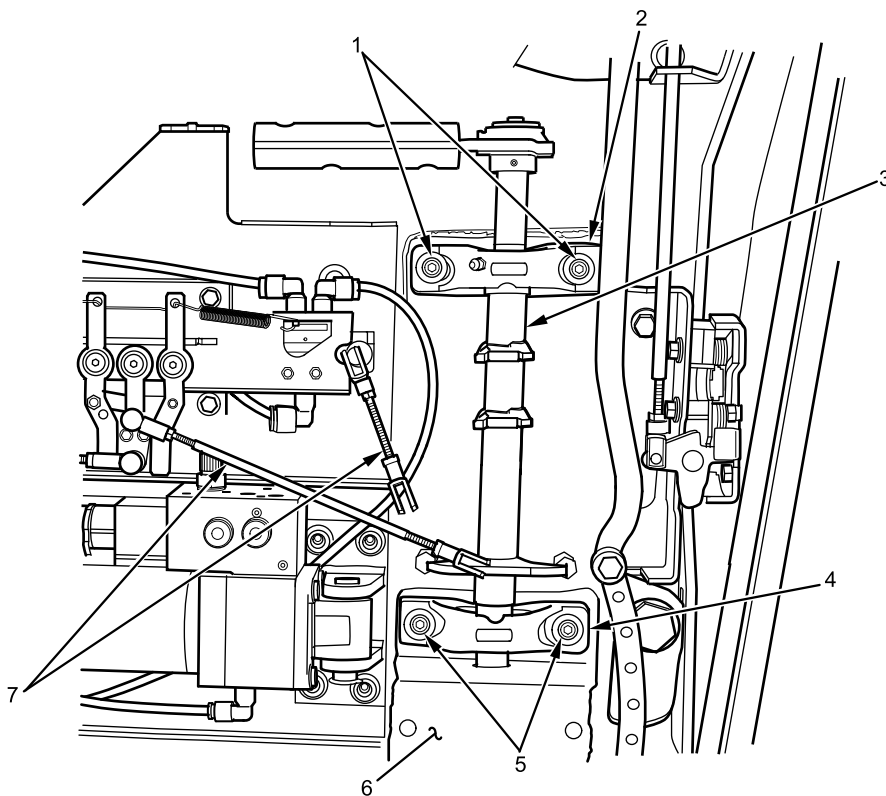

B231804791

Figure 10. Cabin Door Interior Handle Assembly.

1. Apply sealing compound to mating surface of inner shaft plate bracket (Figure 10, Item 6).
2. Carefully position two linkage rods (Figure 10, Item 7) aside.
3. Install cabin door interior handle assembly (Figure 10, Item 3) into position on vehicle inner door frame.
4. Loosely install two socket-head shoulder screws (Figure 10, Item 1) and washers in upper bearing block (Figure 10, Item 2), fastening cabin door interior handle assembly (Figure 10, Item 3) to inner door frame. Do not tighten screws.
5. Install two socket-head shoulder screws (Figure 10, Item 5) and washers in lower bearing block (Figure 10, Item 4), fastening cabin door interior handle assembly (Figure 10, Item 3) to inner door frame.
6. Torque four socket-head shoulder screws (Figure 10, Item 1 and 5) to 17 lb-ft (23 N•m).
7. Install lower linkage rod (Figure 11, Item 8) on lock mechanism assembly (Figure 11, Item 6) and lock handle (Figure 11, Item 12) with clevis retaining clip (Figure 11, Item 7) and nut (Figure 11, Item 11). Tighten nut securely.

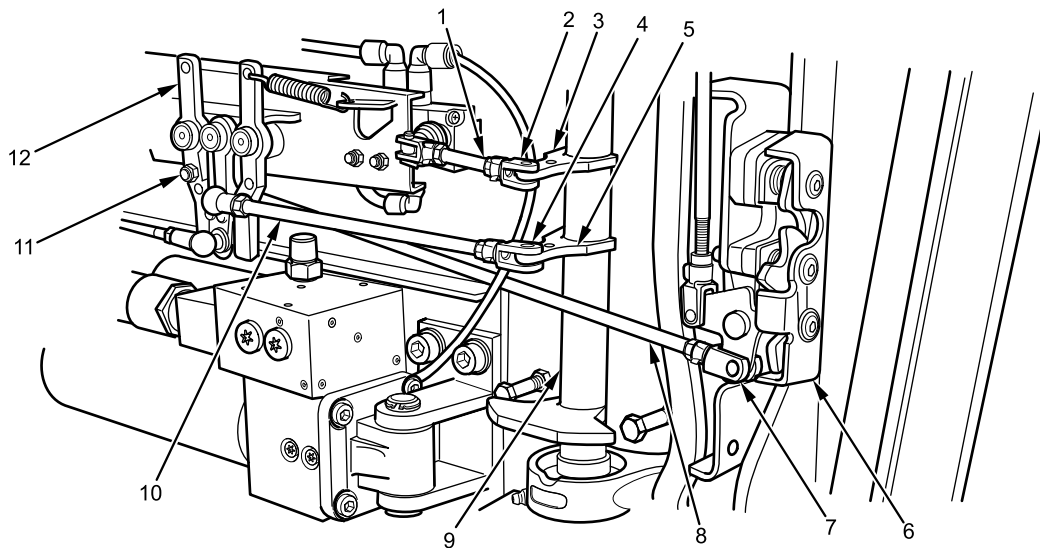
CABIN DOOR INTERIOR HANDLE ASSEMBLY REMOVAL AND INSTALLATION (SINGLE-PISTON, LOWER COMBAT DOOR LOCK-TYPE) - (CONTINUED)

B231810876

Figure 11. Retaining Clips and Door Linkage Rods.

8. Connect upper linkage rod (Figure 11, Item 1) to cabin door interior handle assembly (Figure 11, Item 9) upper bracket (Figure 11, Item 3) with clevis retaining clip (Figure 11, Item 2).
9. Connect middle linkage rod (Figure 11, Item 10) to cabin door interior handle assembly (Figure 11, Item 9) middle bracket (Figure 11, Item 5) with clevis retaining clip (Figure 11, Item 4).

CABIN DOOR INTERIOR HANDLE ASSEMBLY REMOVAL AND INSTALLATION (SINGLE-PISTON, LOWER COMBAT DOOR LOCK-TYPE) - (CONTINUED)

10. Install combat lock shaft lever (Figure 12, Item 6) in combat lock bellcrank bolthole (Figure 12, Item 1) with hex bolt (Figure 12, Item 5) and washer. Tighten bolt securely.

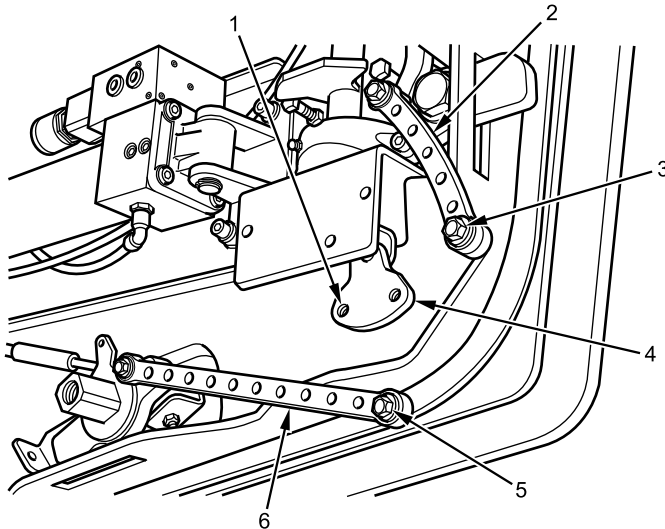

B231804699

Figure 12. Combat Lock Shaft Lever and Vertical Shaft Lever to Combat Lock Bellcrank.

11. Install vertical shaft lever (Figure 12, Item 2) on combat lock bellcrank (Figure 12, Item 4) with hex bolt (Figure 12, Item 3) and washer. Tighten bolt securely.
12. Test cabin door manually and verify exterior door handle latch operation. Adjust as required if door fails to latch, or if handle does not work properly.
13. Install two hex bolts (Figure 13, Item 1) and washers on top of inner shaft lockplate bracket (Figure 13, Item 2). Tighten bolts securely.

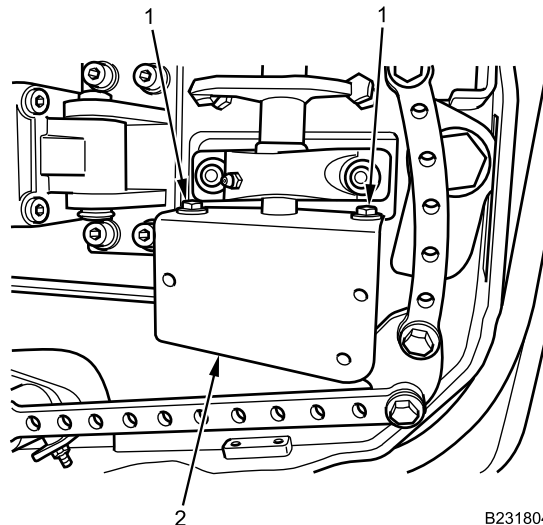

B231804698

Figure 13. Hex Bolts Installed on Inner Shaft Lockplate Bracket.

CABIN DOOR INTERIOR HANDLE ASSEMBLY REMOVAL AND INSTALLATION (SINGLE-PISTON, LOWER COMBAT DOOR LOCK-TYPE) - (CONTINUED)

14. Install inner door handle shaft cover plate (Figure 14, Item 3) on inner shaft lockplate bracket (Figure 14, Item 2) with two hex bolts (Figure 14, Item 1) and washers. Tighten bolts securely.

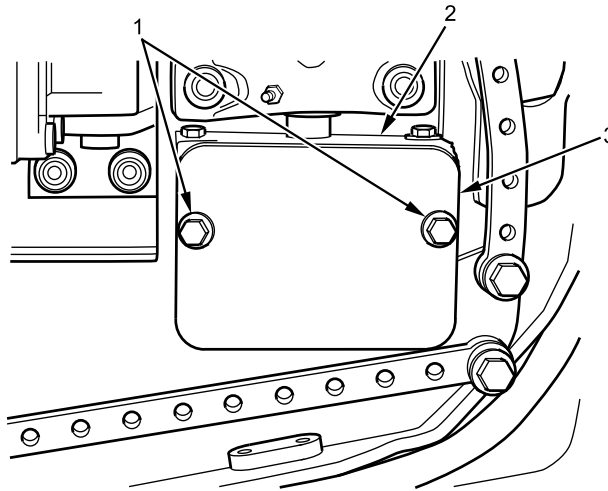

B231804697

Figure 14. Inner Door Handle Shaft Cover Plate.

END OF TASK

FOLLOW-ON MAINTENANCE

1. Turn MAIN POWER switch on (TM 9-2355-106-10).
2. Start engine (TM 9-2355-106-10).
3. Verify air pressure on gauges reads above 75 psi (TM 9-2355-106-10).
4. Verify interior and exterior door handle assemblies and inner cabin door latches for proper operation. Adjust as required if door fails to latch, or if interior handle does not work properly (WP 0615).
5. Install door trim (WP 0626).
6. Turn engine off (TM 9-2355-106-10).
7. Turn MAIN POWER switch off (TM 9-2355-106-10).
8. Close cabin door (WP 0608).
9. Remove wheel chocks (TM 9-2355-106-10).

END OF TASK

END OF WORK PACKAGE

FIELD MAINTENANCE**CABIN DOOR INTERIOR HANDLE ASSEMBLY REMOVAL AND INSTALLATION (DUAL PISTON UPPER INTERIOR COMBAT DOOR LOCK-TYPE)**

INITIAL SETUP:**Tools and Special Tools**

General Mechanic's Tool Kit (GMTK)
(WP 0795, Item 37)
Hammer, hand, soft face, dead blow 10 oz
(WP 0795, Item 44)
Puller set, mechanical (WP 0795, Item 78)
Socket driver, 3/8-inch drive, chrome, hex 6 mm
(WP 0795, Item 94)
Wrench, torque, 20-100 ft-lb, 3/8-inch drive
(WP 0795, Item 141)

Materials/Parts

Compound (WP 0794, Item 13)
Sealing compound (WP 0794, Item 43)
Sealing compound (WP 0794, Item 45)
Adhesive (WP 0794, Item 3)

References

TM 9-2355-106-10
TM 9-2355-106-23P
WP 0782

Equipment Condition

Parking brake set (TM 9-2355-106-10)
Transmission set in NEUTRAL (N) (TM 9-2355-106-10)
Engine off (TM 9-2355-106-10)
MAIN POWER switch off (TM 9-2355-106-10)
Wheels chocked (TM 9-2355-106-10)
Air tanks and reservoirs drained (TM 9-2355-106-10)
Cabin door trim panel removed (WP 0626)
Cabin door secured safely open (WP 0608)

CABIN DOOR INTERIOR HANDLE ASSEMBLY REMOVAL AND INSTALLATION (DUAL PISTON UPPER INTERIOR COMBAT DOOR LOCK-TYPE) - (CONTINUED)

WARNING



Cabin door must be secured in the open position by using heavy duty winch straps to prevent accidental closure during vehicle maintenance. Pull door hinge pin prior to securing door open. Failure to comply may result in serious injury or death to personnel.

Use the appropriate lifting strap sling or chain hoist for the type of load. Always clean and inspect lifting strap slings and chain hoists prior to use. Inspect for damage such as wear, corrosion, elongation, tears, or punctures. Replace lifting strap slings or chain hoists that are damaged. Failure to comply may result in component damage and death or injury to personnel.

NOTE

Cabin door interior handle assembly removal and installation work package instructions should be discussed prior to starting the task to ensure instructions are understood by all participants. Mark and label all connections and reference areas before removal of component parts.

This procedure shows left door; right door procedure similar.

REMOVAL

NOTE

Note orientation of cabin door inner combat lock latch handle for later installation.

Removal of quick release pin will permit cabin door to be opened wider to provide greater access to inner door component parts.

1. Remove two hex bolts (Figure 1, Item 1) securing door handle shaft cover plate (Figure 1, Item 3) to inner shaft lockplate bracket (Figure 1, Item 2). Remove shaft cover plate.

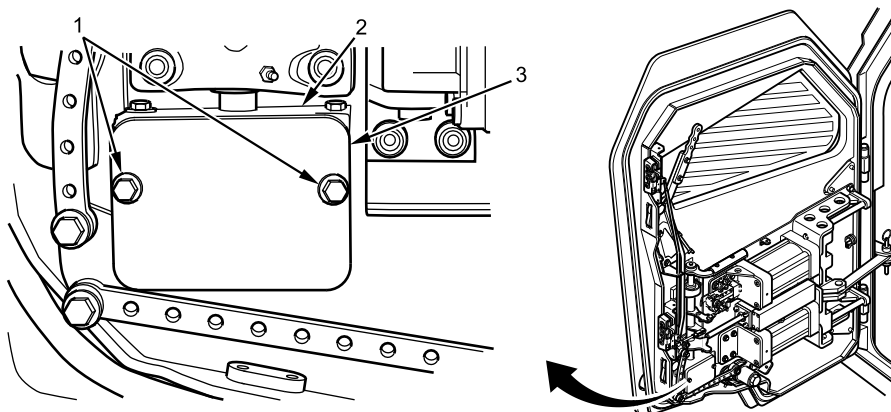

B231811706

Figure 1. Inner Door Handle Shaft Cover Plate Removal.

CABIN DOOR INTERIOR HANDLE ASSEMBLY REMOVAL AND INSTALLATION (DUAL PISTON UPPER INTERIOR COMBAT DOOR LOCK-TYPE) - (CONTINUED)

- Remove two hex bolts (Figure 2, Item 1) and washers (Figure 2, Item 3) from top of inner shaft lockplate bracket (Figure 2, Item 2).

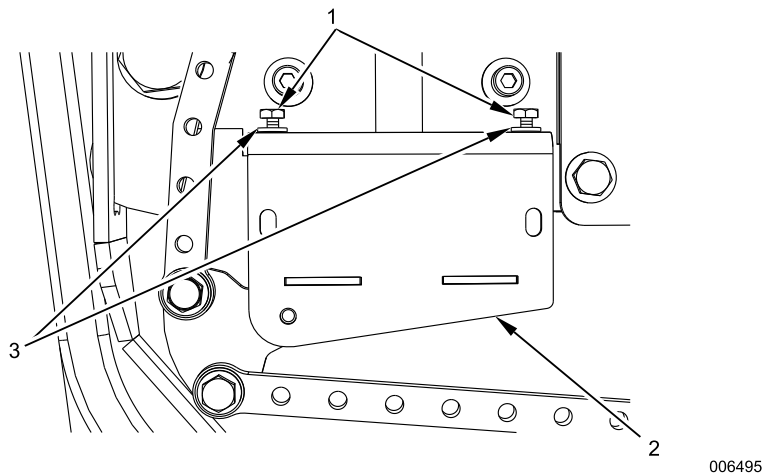

Figure 2. Upper Hex Bolt Removal from Inner Shaft Lockplate Bracket.

NOTE

Inner shaft lockplate bracket does not separate from interior handle shaft.

- Remove hex bolt (Figure 3, Item 1) fastening vertical shaft lever (Figure 3, Item 2) to combat lock bellcrank (Figure 3, Item 5).

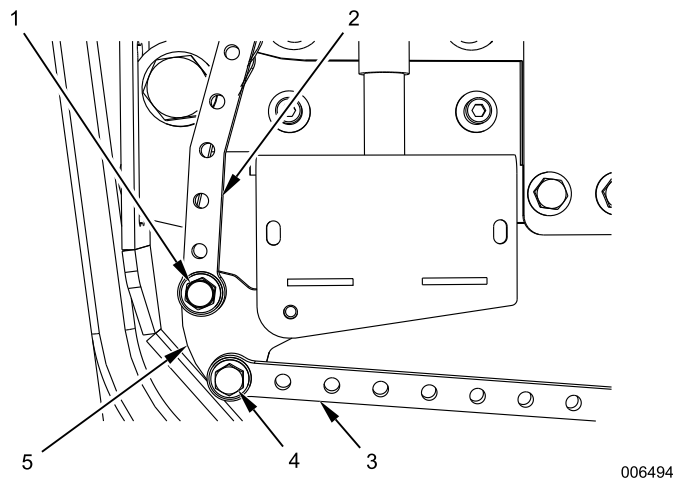

Figure 3. Combat Lock Shaft Lever and Vertical Shaft Lever Removal from Combat Lock Bellcrank.

- Remove hex bolt (Figure 3, Item 4) and washer fastening combat lock shaft lever (Figure 3, Item 3) to combat lock bellcrank (Figure 3, Item 5).

CABIN DOOR INTERIOR HANDLE ASSEMBLY REMOVAL AND INSTALLATION (DUAL PISTON UPPER INTERIOR COMBAT DOOR LOCK-TYPE) - (CONTINUED)

NOTE

When clevis retaining clips are removed or disconnected, linkage rods will rotate freely away from inner door to provide access to inner door components.

5. Remove clevis retaining clip (Figure 4, Item 2) connecting upper linkage rod (Figure 4, Item 3) to cabin door interior handle assembly (Figure 4, Item 1).

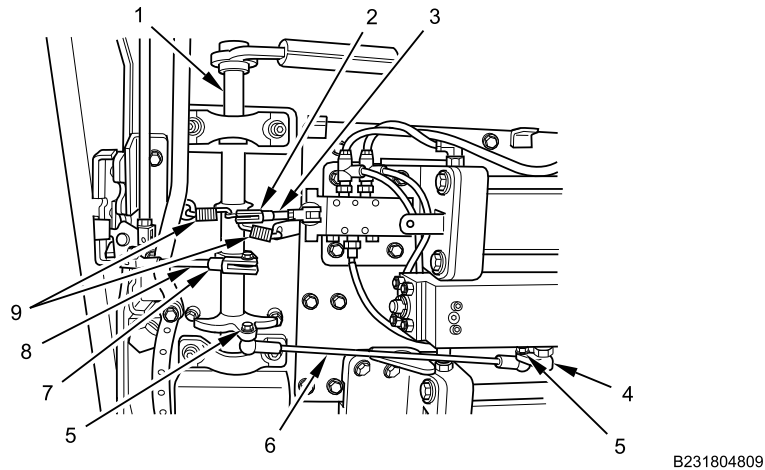

Figure 4. Retaining Clips, Springs, and Door Linkage Rods Removal.

6. Remove actuator link rod springs (Figure 4, Item 9) from cabin door interior handle assembly (Figure 4, Item 1).
7. Remove clevis retaining clip (Figure 4, Item 7) connecting middle linkage rod (Figure 4, Item 8) to cabin door interior handle assembly (Figure 4, Item 1).
8. Remove two nuts (Figure 4, Item 5) from lower linkage rod (Figure 4, Item 6).

NOTE

Replace lower linkage rod if ball studs are stiff or binding during removal.

9. Remove lower linkage rod (Figure 4, Item 6) from lock arm (Figure 4, Item 4) and cabin door interior handle assembly (Figure 4, Item 1).

CABIN DOOR INTERIOR HANDLE ASSEMBLY REMOVAL AND INSTALLATION (DUAL PISTON UPPER INTERIOR COMBAT DOOR LOCK-TYPE) - (CONTINUED)

10. Loosen, but do not remove, two upper socket-head shouldered screws (Figure 5, Item 9) fastening upper bearing block (Figure 5, Item 2) to door (Figure 5, Item 10).

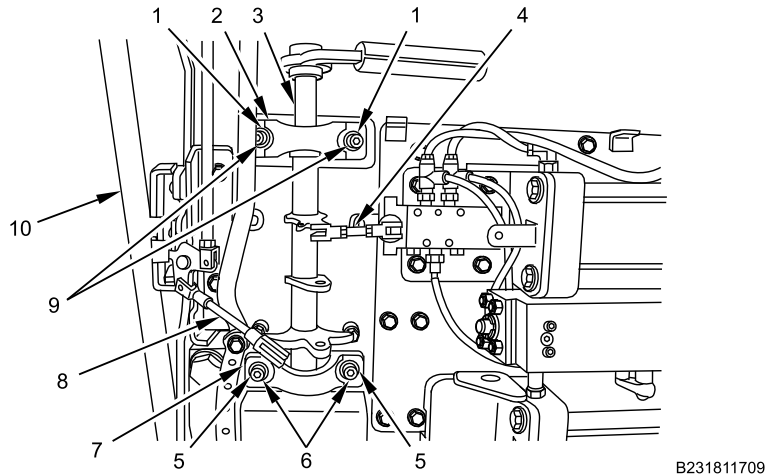

Figure 5. Cabin Door Interior Handle Assembly Removal.

CAUTION

When removing cabin door interior handle assembly, make sure linkage rods are not twisted or bent during removal procedure. Failure to comply may result in damage to equipment.

11. Carefully position two linkage rods (Figure 5, Item 4 and 8) away from cabin door interior handle assembly (Figure 5, Item 3). Use minimal force when moving rods.

NOTE

Cabin door interior handle assembly will remain upright and not fall down after removal of screws.

12. Remove two lower socket-head shouldered screws (Figure 5, Item 6) and washers (Figure 5, Item 5) fastening lower bearing block (Figure 5, Item 7) to door (Figure 5, Item 10).

NOTE

Following removal of socket-head shouldered screws and washers, cabin door interior handle assembly will remain in upright position, but will no longer be secured to inner door frame.

13. From inside cabin door, support cabin door interior handle assembly (Figure 5, Item 3). Remove two upper socket-head shouldered screws (Figure 5, Item 9) and washers (Figure 5, Item 1) fastening upper bearing block (Figure 5, Item 2) to door (Figure 5, Item 10).
14. Carefully remove cabin door interior handle assembly (Figure 5, Item 3) from door (Figure 5, Item 10).

END OF TASK

CABIN DOOR INTERIOR HANDLE ASSEMBLY REMOVAL AND INSTALLATION (DUAL PISTON UPPER INTERIOR COMBAT DOOR LOCK-TYPE) - (CONTINUED)

DISASSEMBLY

1. Place cabin door interior handle assembly (Figure 6, Item 1) on bench or suitable work area.

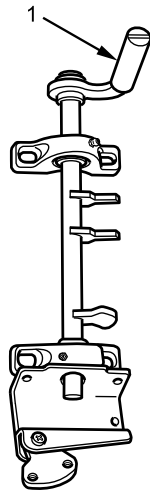

B231802438

Figure 6. Cabin Door Interior Handle Assembly Removed.

2. Remove bolt (Figure 7, Item 10) and washer (Figure 7, Item 9) retaining exterior door handle (Figure 7, Item 11) to shaft assembly (Figure 7, Item 17).

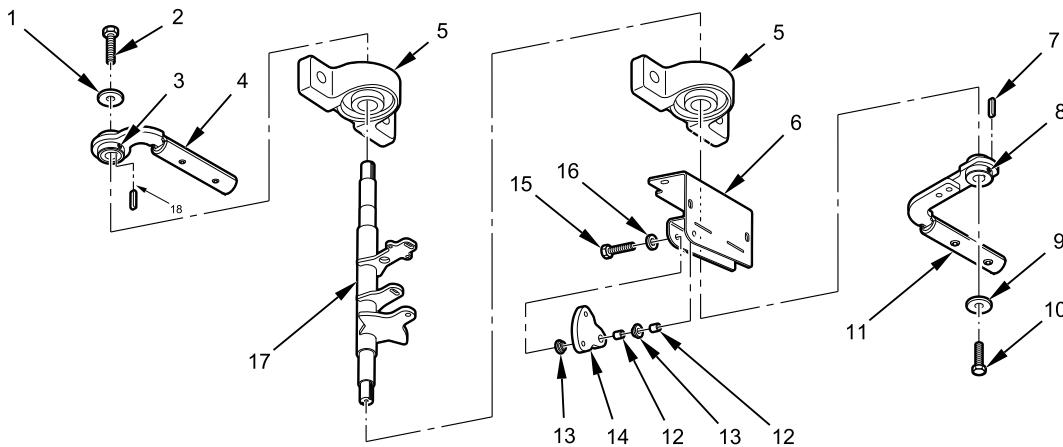

B231805287

Figure 7. Cabin Door Interior Handle Disassembly.

CABIN DOOR INTERIOR HANDLE ASSEMBLY REMOVAL AND INSTALLATION (DUAL PISTON UPPER INTERIOR COMBAT DOOR LOCK-TYPE) - (CONTINUED)

3. Loosen setscrew (Figure 7, Item 8) in exterior door handle (Figure 7, Item 11).
4. Using mechanical puller, remove exterior door handle (Figure 7, Item 11) and key (Figure 7, Item 7) from shaft assembly (Figure 7, Item 17).
5. Remove bolt (Figure 7, Item 2) and washer (Figure 7, Item 1) retaining interior door handle (Figure 7, Item 4) to shaft assembly (Figure 7, Item 17).
6. Loosen setscrew (Figure 7, Item 3) in interior door handle (Figure 7, Item 4).
7. Using mechanical puller, remove interior door handle (Figure 7, Item 4) and key (Figure 7, Item 18) from shaft assembly (Figure 7, Item 17).
8. Remove bolt (Figure 7, Item 15), washer (Figure 7, Item 16), bearings (Figure 7, Item 13), crank spacers (Figure 7, Item 12), and crank (Figure 7, Item 14) from bracket (Figure 7, Item 6).
9. Remove bracket (Figure 7, Item 6) from shaft assembly (Figure 7, Item 17).
10. Using mechanical puller, remove two bearing blocks (Figure 7, Item 5) from shaft assembly (Figure 7, Item 17).
11. Clean residual sealing compound from mating surface of inner shaft plate bracket (Figure 7, Item 6).

END OF TASK

CABIN DOOR INTERIOR HANDLE ASSEMBLY REMOVAL AND INSTALLATION (DUAL PISTON UPPER INTERIOR COMBAT DOOR LOCK-TYPE) - (CONTINUED)

ASSEMBLY

WARNING



Thread sealing compound is harmful to skin and eyes. If thread sealing compound contacts eyes, rinse thoroughly and contact physician if irritation persists. If skin is contacted, wash thoroughly with soap and water. Failure to comply may result in serious injury to personnel.

- Using soft face hammer, install two bearing blocks (Figure 8, Item 5) on shaft assembly (Figure 8, Item 17).

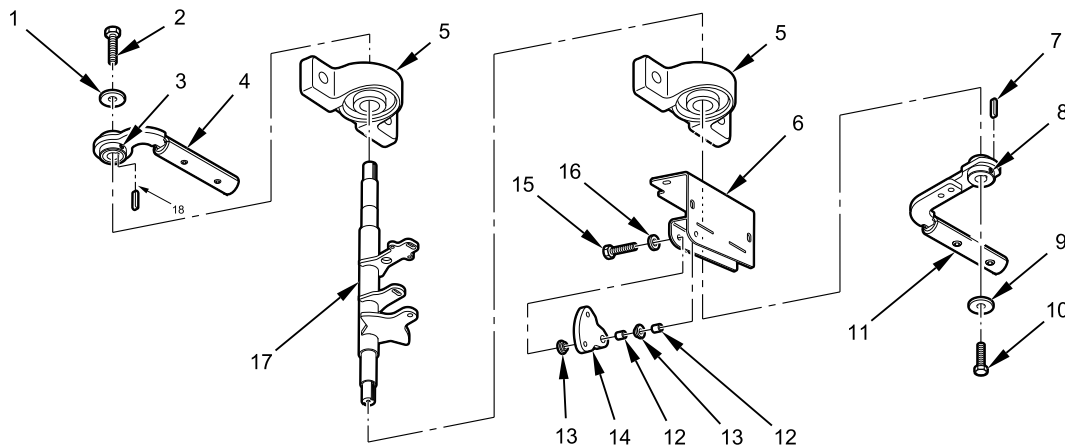

B231805287

Figure 8. Cabin Door Interior Handle Assembly.

- Install bracket (Figure 8, Item 6) on shaft assembly (Figure 8, Item 17).
- Apply thread sealing compound to hex head bolt (Figure 8, Item 15) and washer (Figure 8, Item 16).
- Install crank (Figure 8, Item 14), crank spacers (Figure 8, Item 12), and bearings (Figure 8, Item 13) on bracket (Figure 8, Item 6) with bolt (Figure 8, Item 15) and washer (Figure 8, Item 16). Tighten bolt securely.
- Using soft face hammer, install interior door handle (Figure 8, Item 4) and key (Figure 8, Item 18) on shaft assembly (Figure 8, Item 17).
- Tighten setscrew (Figure 8, Item 3) on interior door handle (Figure 8, Item 4) securely.
- Apply thread sealing compound to hex head bolt (Figure 8, Item 2) and washer (Figure 8, Item 1).
- Install bolt (Figure 8, Item 2) and washer (Figure 8, Item 1) securing interior door handle (Figure 8, Item 4) to shaft assembly (Figure 8, Item 17). Tighten bolt securely.
- Using soft face hammer, install exterior door handle (Figure 8, Item 11) and key (Figure 8, Item 7) on shaft assembly (Figure 8, Item 17).
- Tighten setscrew (Figure 8, Item 8) on exterior door handle (Figure 8, Item 11) securely.
- Apply thread sealing compound to hex head bolt (Figure 8, Item 10) and washer (Figure 8, Item 9).
- Install bolt (Figure 8, Item 10) and washer (Figure 8, Item 9) securing exterior door handle (Figure 8, Item 11) to shaft assembly (Figure 8, Item 17). Tighten bolt securely.

END OF TASK

CABIN DOOR INTERIOR HANDLE ASSEMBLY REMOVAL AND INSTALLATION (DUAL PISTON UPPER INTERIOR COMBAT DOOR LOCK-TYPE) - (CONTINUED)

INSTALLATION

WARNING

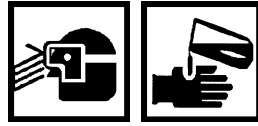

Thread sealing compound is harmful to skin and eyes. If thread sealing compound contacts eyes, rinse thoroughly and contact physician if irritation persists. If skin is contacted, wash thoroughly with soap and water. Failure to comply may result in serious injury to personnel.

1. Apply sealing compound to mating surface of inner shaft lockplate bracket (Figure 9, Item 6).

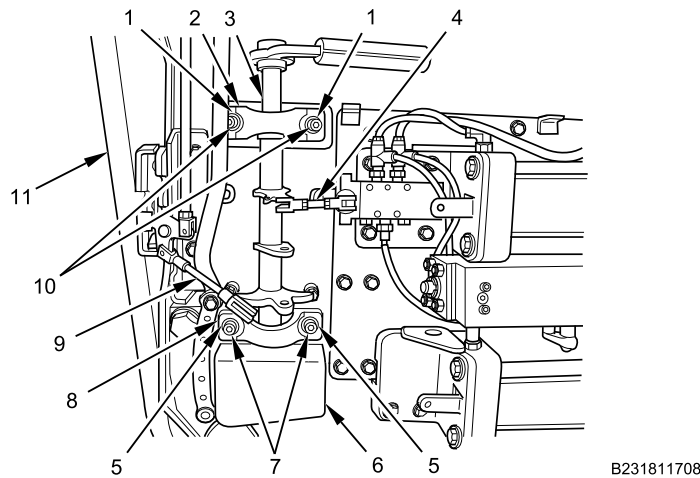

Figure 9. Cabin Door Interior Handle Assembly Installation.

2. Carefully position two linkage rods (Figure 9, Item 4 and 9) aside.
3. Install cabin door interior handle assembly (Figure 9, Item 3) into position on vehicle door (Figure 9, Item 11).
4. Apply thread sealing compound to four socket-head shouldered screws (Figure 9, Item 7 and 10) and washers (Figure 9, Item 1 and 5).
5. Loosely install two socket-head shoulder screws (Figure 9, Item 10) and washers (Figure 9, Item 1) in upper bearing block (Figure 9, Item 2), fastening cabin door interior handle assembly (Figure 9, Item 3) to door (Figure 9, Item 11). Do not tighten screws.
6. Install two socket-head shoulder screws (Figure 9, Item 7) and washers (Figure 9, Item 5) in lower bearing block (Figure 9, Item 8), fastening cabin door interior handle assembly (Figure 9, Item 3) to vehicle door (Figure 9, Item 11).
7. Torque four socket-head shoulder screws (Figure 9, Item 7 and 10) to 17 lb-ft (23 N•m).

CABIN DOOR INTERIOR HANDLE ASSEMBLY REMOVAL AND INSTALLATION (DUAL PISTON UPPER INTERIOR COMBAT DOOR LOCK-TYPE) - (CONTINUED)

8. Install lower linkage rod (Figure 10, Item 6) on lock arm (Figure 10, Item 4) and cabin door interior handle assembly (Figure 10, Item 1) with two nuts (Figure 10, Item 5). Tighten nuts securely.

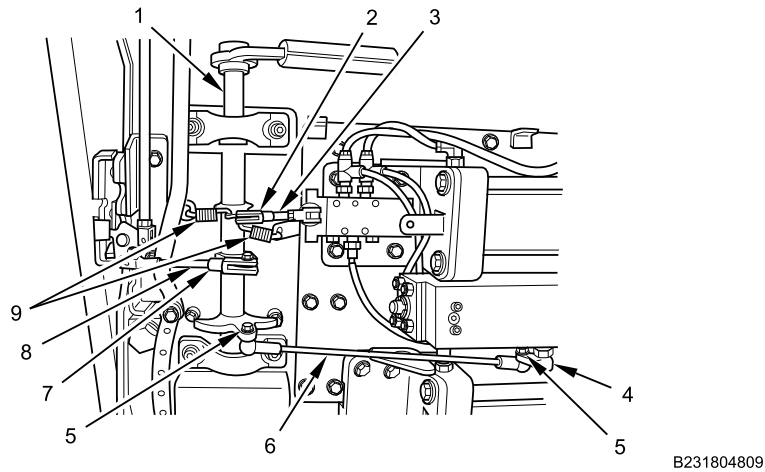

Figure 10. Retaining Clips, Springs, and Door Linkage Rods Installation.

9. Connect middle linkage rod (Figure 10, Item 8) to cabin door interior handle (Figure 10, Item 1) with clevis retaining clip (Figure 10, Item 7).
10. Install actuator link rod springs (Figure 10, Item 9) on cabin interior door handle assembly (Figure 10, Item 1).
11. Connect upper linkage rod (Figure 10, Item 3) to cabin door interior handle assembly (Figure 10, Item 1) with clevis retaining clip (Figure 10, Item 2).
12. Install combat lock shaft lever (Figure 11, Item 3) on combat lock bellcrank (Figure 11, Item 5) with hex bolt (Figure 11, Item 4). Tighten bolt securely.

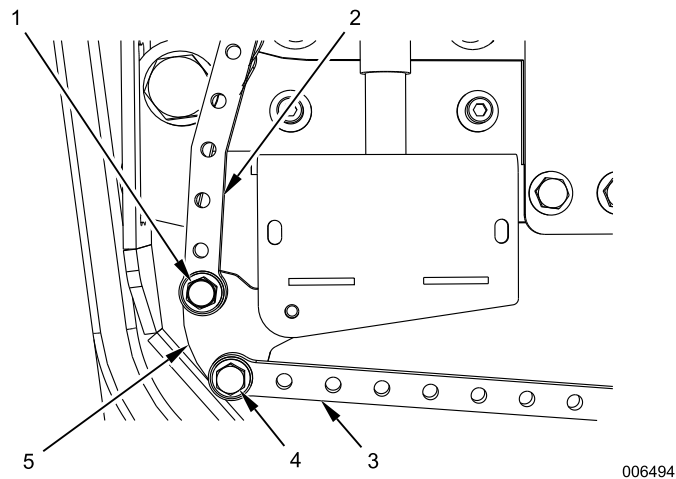

Figure 11. Combat Lock Shaft Lever and Vertical Shaft Lever Installed on Bellcrank.

13. Install vertical shaft lever (Figure 11, Item 2) on combat lock bellcrank (Figure 11, Item 5) with hex bolt (Figure 11, Item 1). Tighten bolt securely.

CABIN DOOR INTERIOR HANDLE ASSEMBLY REMOVAL AND INSTALLATION (DUAL PISTON UPPER INTERIOR COMBAT DOOR LOCK-TYPE) - (CONTINUED)

14. Test cabin door manually and verify exterior door handle latch operation. Adjust as required if door fails to latch, or if handle does not work properly.
15. Install two hex bolts (Figure 12, Item 1) and washers (Figure 12, Item 3) on top of inner shaft lockplate bracket (Figure 12, Item 2). Tighten bolts securely.

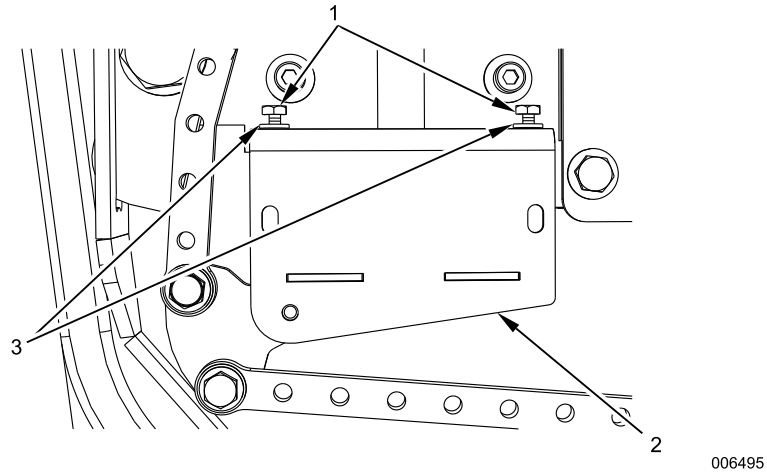

Figure 12. Hex Bolts Installed on Inner Shaft Lockplate Bracket.

16. Install inner door handle shaft cover plate (Figure 13, Item 3) on inner shaft lockplate bracket (Figure 13, Item 2) with two hex bolts (Figure 13, Item 1). Tighten bolts securely.

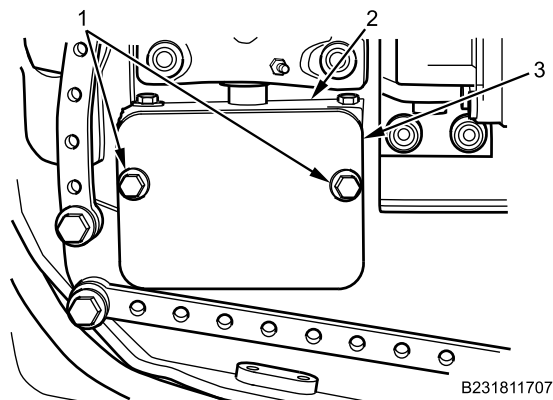

Figure 13. Inner Door Handle Shaft Cover Plate Installation.

END OF TASK

CABIN DOOR INTERIOR HANDLE ASSEMBLY REMOVAL AND INSTALLATION (DUAL PISTON UPPER INTERIOR COMBAT DOOR LOCK-TYPE) - (CONTINUED)**FOLLOW-ON MAINTENANCE**

1. Install cabin door trim panel (WP 0626).
2. Turn MAIN POWER switch on (TM 9-2355-106-10).
3. Start engine (TM 9-2355-106-10).
4. Verify air pressure on gauges (TM 9-2355-106-10).
5. Verify interior and exterior door handle assemblies and inner cabin door latches for proper operation. Adjust as required if door fails to latch or if interior handle does not work properly (TM 9-2355-106-10).
6. Turn engine off (TM 9-2355-106-10).
7. Turn MAIN POWER switch off (TM 9-2355-106-10).
8. Remove wheel chocks (TM 9-2355-106-10).

END OF TASK**END OF WORK PACKAGE**

FIELD MAINTENANCE
CABIN DOOR TRIM PANEL REMOVAL AND INSTALLATION (ONE-PIECE, LOWER COMBAT DOOR LOCK-TYPE)

INITIAL SETUP:**Tools and Special Tools**

General Mechanic's Tool Kit (GMTK)
(WP 0795, Item 37)
Gloves, rubber (WP 0795, Item 38)

TM 9-2355-106-23P
WP 0786
WP 0782

Materials/Parts

Faceshield, industrial (WP 0794, Item 16)
Goggles, industrial (WP 0794, Item 20)
Compound (WP 0794, Item 13)
Gloves (WP 0794, Item 18)

Equipment Condition

Parking brake set (TM 9-2355-106-10)
Transmission set in NEUTRAL (N) (TM 9-2355-106-10)
Engine off (TM 9-2355-106-10)
MAIN POWER switch off (TM 9-2355-106-10)
Wheels chocked (TM 9-2355-106-10)
Cabin door open and secure (WP 0608)

References

TM 9-2355-106-10

WARNING

Cabin door must be secured in the open position by using heavy duty winch straps to prevent accidental closure during vehicle maintenance. Pull door hinge pin prior to securing door open. Failure to comply may result in serious injury or death to personnel.

Use the appropriate lifting strap sling or chain hoist for the type of load. Always clean and inspect lifting strap slings and chain hoists prior to use. Inspect for damage such as wear, corrosion, elongation, tears, or punctures. Replace lifting strap slings or chain hoists that are damaged. Failure to comply may result in component damage and death or injury to personnel.

NOTE

Vehicle is equipped with either a single-piston or dual-piston door assist. If the door trim panel is one piece, the single piston system is used. If the door trim panel is two pieces, the dual-piston system is used. If parts are unavailable, upgrade to the two piece door trim panel/dual-piston system. Note orientation of cabin door inner combat lock latch handle for later installation.

CABIN DOOR TRIM PANEL REMOVAL AND INSTALLATION (ONE-PIECE, LOWER COMBAT DOOR LOCK-TYPE) - (CONTINUED)

REMOVAL

1. Remove bolt (Figure 1, Item 3), washer (Figure 1, Item 2), and inside combat lock latch handle (Figure 1, Item 4) to inner door frame (Figure 1, Item 1).

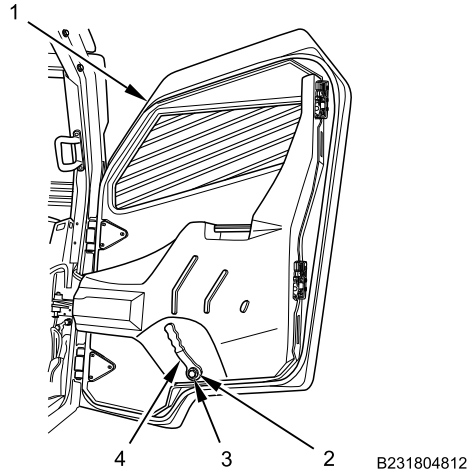

Figure 1. Inside Door Combat Lock Handle Removal.

2. Remove 12 fasteners (Figure 2, Item 2) securing cabin door trim panel (Figure 2, Item 3) to door. Set fasteners aside.

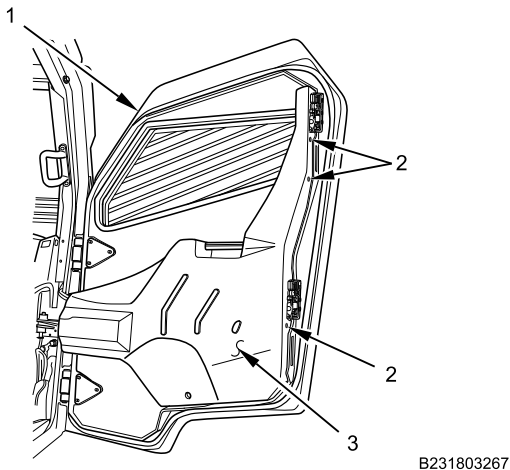

Figure 2. Cabin Door Trim Panel Fasteners Removal.

3. Remove cabin door trim panel (Figure 2, Item 3) from inner door frame (Figure 2, Item 1).

END OF TASK

CABIN DOOR TRIM PANEL REMOVAL AND INSTALLATION (ONE-PIECE, LOWER COMBAT DOOR LOCK-TYPE) - (CONTINUED)**INSTALLATION****WARNING**

Corrosion preventive compound is toxic. Use only in well-ventilated area. Do not get in eyes; wear chemical safety goggles and full-face shield when using. Avoid contact with skin and wear rubber or plastic, solvent-resistant gloves. In case of contact, remove contaminated clothing and immediately wash area with soap and water. If compound contacts eyes, flush eyes with large amounts of water for at least 15 minutes and get immediate medical attention. If swallowed, do not induce vomiting; contact a physician immediately. Failure to comply may result in serious injury or death to personnel.

1. Install cabin door trim panel (Figure 3, Item 3) on inner door frame (Figure 3, Item 1) with 12 fasteners (Figure 3, Item 2).

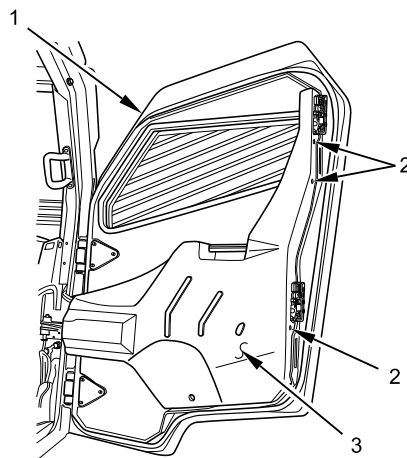

B231803267

Figure 3. Cabin Door Trim Panel Fasteners Installation.

CABIN DOOR TRIM PANEL REMOVAL AND INSTALLATION (ONE-PIECE, LOWER COMBAT DOOR LOCK-TYPE) - (CONTINUED)

2. Apply corrosion preventive compound to bolt (Figure 4, Item 3) and washer (Figure 4, Item 2).

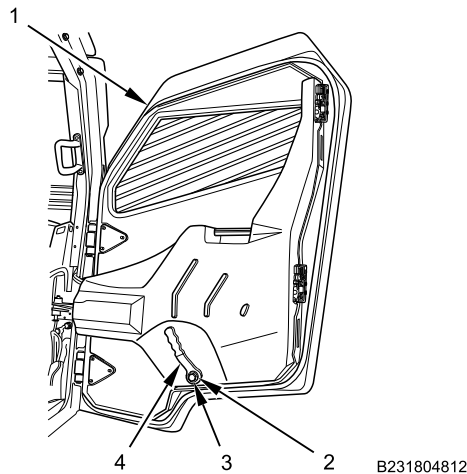

Figure 4. Door Interior Combat Lock Handle Installation.

3. Install combat lock latch handle (Figure 4, Item 4) on combat lock release shaft of inner door frame (Figure 4, Item 1) with bolt (Figure 4, Item 3) and washer (Figure 4, Item 2). Tighten bolt securely.

END OF TASK**FOLLOW-ON MAINTENANCE**

1. Remove cabin door securing chain hoists and lifting strap (WP 0608).
2. Close cabin door (TM 9-2355-106-10).
3. Remove wheel chocks (TM 9-2355-106-10).

END OF TASK**END OF WORK PACKAGE**

FIELD MAINTENANCE
CABIN DOOR TRIM PANEL REMOVAL AND INSTALLATION (TWO-PIECE, UPPER COMBAT DOOR LOCK TYPE)

INITIAL SETUP:**Tools and Special Tools**

General Mechanic's Tool Kit (GMTK)
(WP 0795, Item 37)

WP 0782

Equipment Condition

Parking brake set (TM 9-2355-106-10)
Transmission set in NEUTRAL (N) (TM
9-2355-106-10)
Engine off (TM 9-2355-106-10)
MAIN POWER switch off (TM 9-2355-106-10)
Wheels chocked (TM 9-2355-106-10)
Cabin door open and secure (WP 0608)

Materials/Parts

Fastener (WP 0794, Item 17)

References

TM 9-2355-106-10
TM 9-2355-106-23P

WARNING

Cabin door must be secured in the open position by using heavy duty straps to prevent accidental closure during vehicle maintenance. Pull check link retaining pin prior to securing door open. Failure to comply may result in serious injury or death to personnel.

Use the appropriate lifting sling and chain hoist for the type of load. Clean lifting strap slings and chain hoists prior to use, and inspect for damage such as wear, corrosion, elongation, tears, or punctures. Replace lifting strap slings and chain hoists that are damaged. Failure to comply may result in damage to equipment and injury or death to personnel.

NOTE

Vehicle is equipped with either a single-piston or dual-piston door assist. If the door trim panel is one piece, the single piston system is used. If the door trim panel is two pieces, the dual-piston system is used. If parts are unavailable, upgrade to the two piece door trim panel/dual-piston system.

CABIN DOOR TRIM PANEL REMOVAL AND INSTALLATION (TWO-PIECE, UPPER COMBAT DOOR LOCK TYPE) - (CONTINUED)**REMOVAL**

1. Remove 22 fasteners (Figure 2, Item 1) that secure trim panels (Figure 2, Item 2) to door. Set fasteners aside.

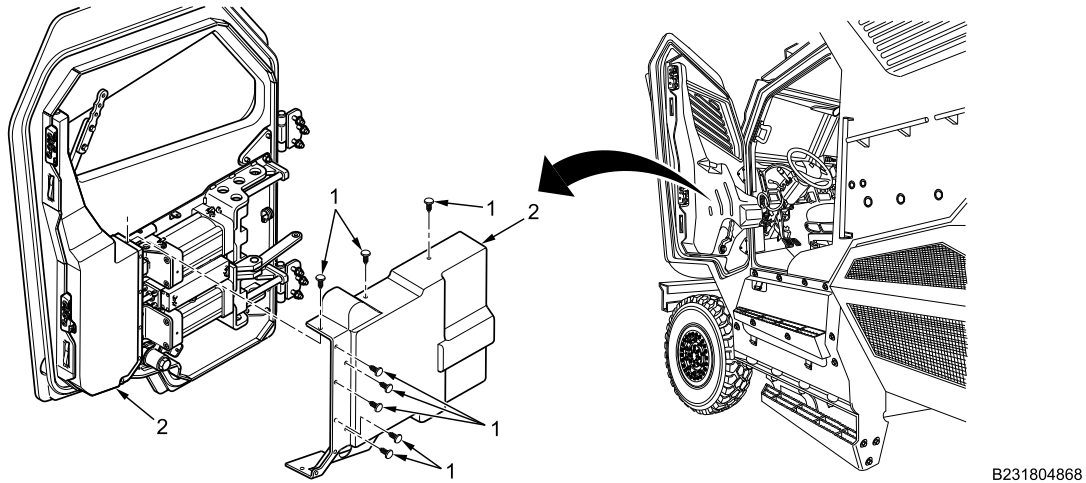
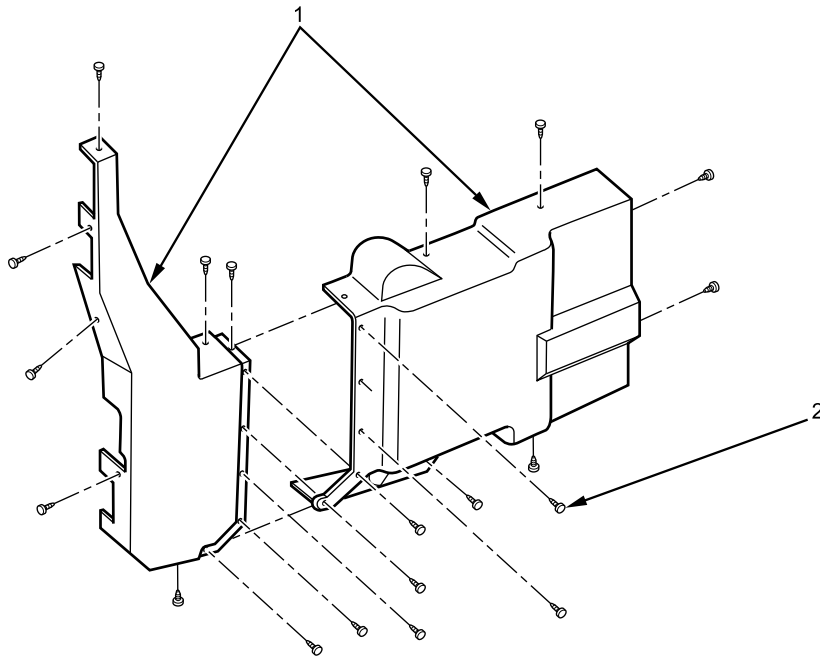

Figure 1. Cabin Door Trim Panel Fasteners Removal.

2. Remove trim panel (Figure 2, Item 2) from inner door frame.

END OF TASK**INSTALLATION**

1. Install door trim panel (Figure 3, Item 1) on interior cabin door with 22 fasteners (Figure 3, Item 2).

CABIN DOOR TRIM PANEL REMOVAL AND INSTALLATION (TWO-PIECE, UPPER COMBAT DOOR LOCK TYPE) - (CONTINUED)

B233302712

Figure 2. Cabin Door Trim Panel Fasteners Installation.

END OF TASK**FOLLOW-ON MAINTENANCE**

1. Remove cabin door securing chain hoists and lifting strap (WP 0608).
2. Close cabin door (TM 9-2355-106-10).
3. Remove wheel chocks (TM 9-2355-106-10).

END OF TASK**END OF WORK PACKAGE**

FIELD MAINTENANCE
CABIN DOOR COMBAT LOCK ASSEMBLY REMOVAL AND INSTALLATION

INITIAL SETUP:**Tools and Special Tools**

General Mechanic's Tool Kit (GMTK)
(WP 0795, Item 37)

References

TM 9-2355-106-10
TM 9-2355-106-23P
WP 0786
WP 0782

Equipment Condition

Parking brake set (TM 9-2355-106-10)

Transmission set in NEUTRAL (N) (TM 9-2355-106-10)

Engine off (TM 9-2355-106-10)

MAIN POWER switch off (TM 9-2355-106-10)

Wheels chocked (TM 9-2355-106-10)

Air tanks and reservoirs drained (TM 9-2355-106-10)

Cabin door open and secured (WP 0608)

Cabin door trim panel removed (WP 0626 [Lower
Combat Door Lock-Type]) or (WP 0627 [Upper
Combat Door Lock-Type])

WARNING

Cabin door must be secured in the open position by using heavy duty straps to prevent accidental closure during vehicle maintenance. Pull check link retaining pin prior to securing door open. Failure to comply may result in serious injury or death to personnel.

Use the appropriate lifting sling and chain hoist for the type of load. Clean lifting strap slings and chain hoists prior to use, and inspect for damage such as wear, corrosion, elongation, tears, or punctures. Replace lifting strap slings and chain hoists that are damaged. Failure to comply may result in damage to equipment and injury or death to personnel.

CABIN DOOR COMBAT LOCK ASSEMBLY REMOVAL AND INSTALLATION - (CONTINUED)**REMOVAL**

1. Remove combat lock cylinder spacer (Figure 1, Item 8) from combat lock release shaft (Figure 1, Item 7). Set lock cylinder spacer aside.

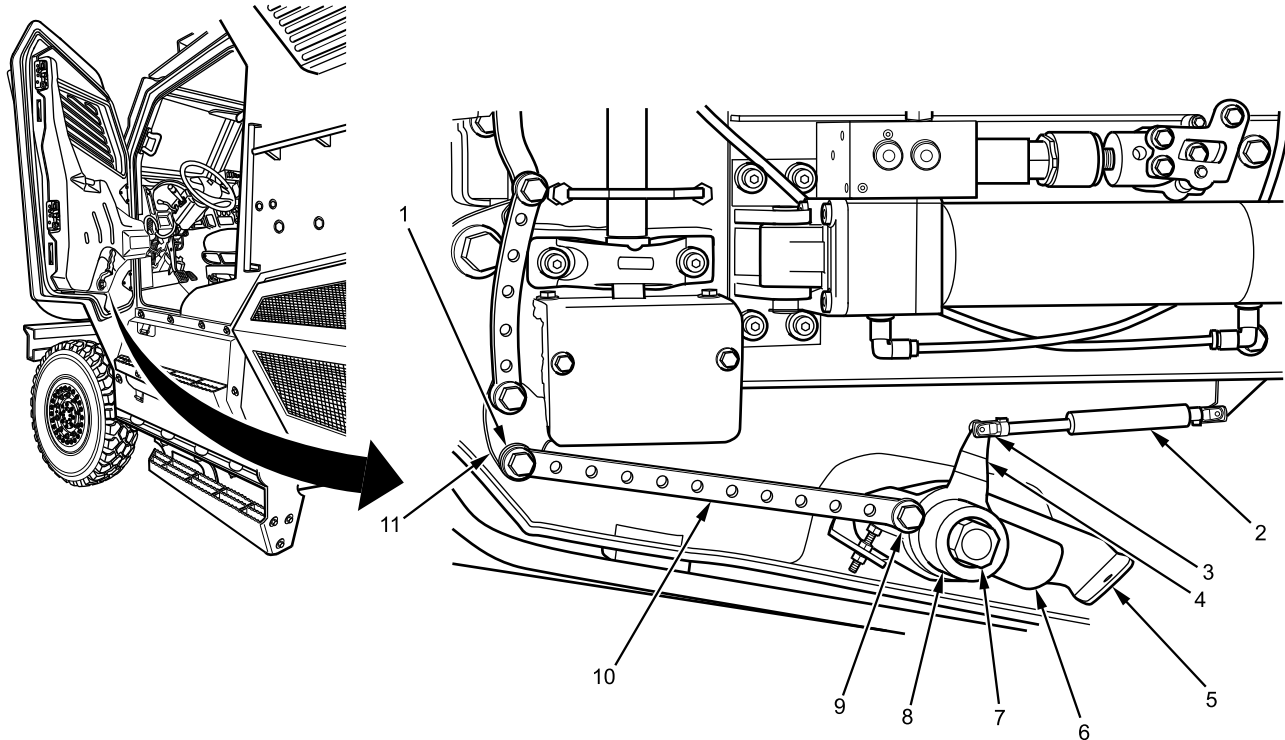

B231804926

Figure 1. Cabin Door Combat Lock Removal.

2. Remove clevis retaining clip (Figure 1, Item 3) connecting gas strut (Figure 1, Item 2) to gas strut lever plate (Figure 1, Item 4). Set retaining clip aside.
3. Remove gas strut lever plate (Figure 1, Item 4) from combat lock assembly release shaft (Figure 1, Item 7). Set gas strut plate aside.
4. Remove washer and inner mounting hex bolt (Figure 1, Item 9) securing combat lock shaft lever (Figure 1, Item 10) to combat lock switch bracket (Figure 1, Item 5). Set bolt and washer aside.
5. Loosen, but do not remove, outer bolt (Figure 1, Item 1) securing combat lock shaft lever (Figure 1, Item 10) to combat lock bell crank (Figure 1, Item 11).
6. Remove spacer and combat lock switch lever (Figure 1, Item 6) from combat lock assembly release shaft (Figure 1, Item 7). Set spacer and lock shaft lever aside.
7. Remove two socket head shouldered screws fastening combat lock two-bolt retainer to inner door-mounted weld nuts. Set screws aside.
8. Remove two-bolt retainer and combat lock switch bracket (Figure 1, Item 5) from combat lock release shaft (Figure 1, Item 7). Set two-bolt retainer and combat lock switch bracket aside.
9. Remove rubber spacer and combat lock assembly release shaft (Figure 1, Item 7) from pass-through hole in door-mounted weld bracket. Set spacer aside.

END OF TASK

CABIN DOOR COMBAT LOCK ASSEMBLY REMOVAL AND INSTALLATION - (CONTINUED)**INSTALLATION**

1. Install cabin door combat lock assembly release shaft and rubber spacer in pass-through hole of door-mounted weld bracket.
2. Using blast/combat lock door key, ensure combat lock assembly release shaft hole (Figure 2, Item 1) is in near-vertical position when combat lock is in unlocked position.

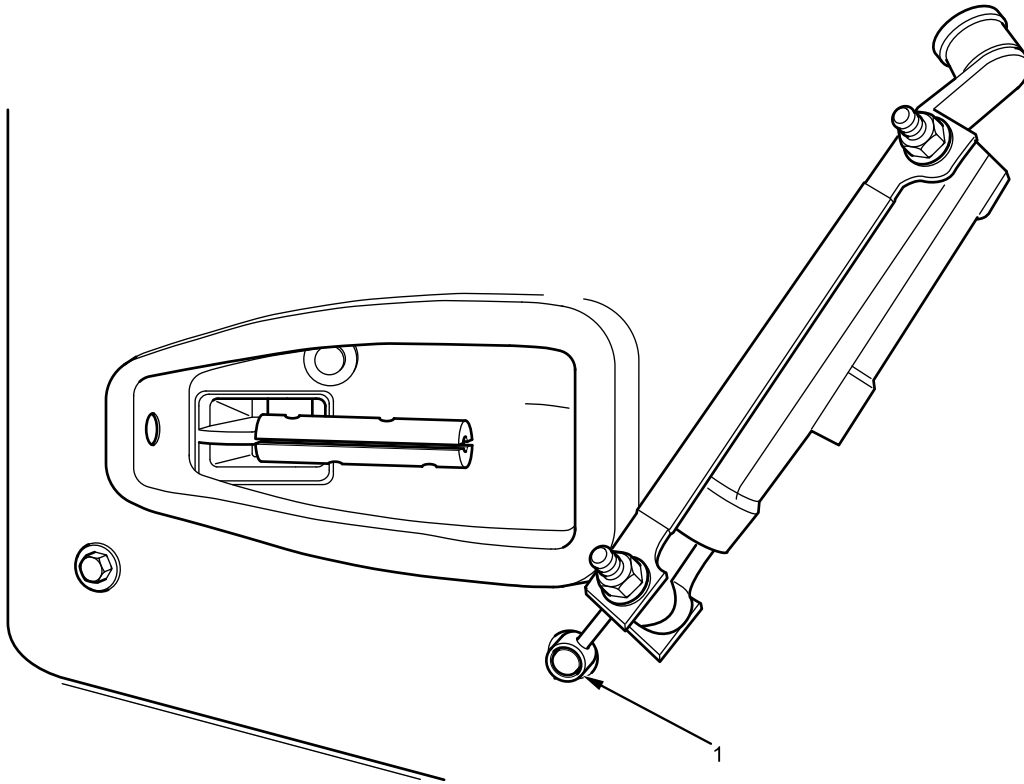

B231803211

Figure 2. Combat Lock Shaft in Near-Vertical Position.

CABIN DOOR COMBAT LOCK ASSEMBLY REMOVAL AND INSTALLATION - (CONTINUED)

3. Install combat lock switch bracket (Figure 3, Item 5) on combat lock release shaft (Figure 3, Item 7).

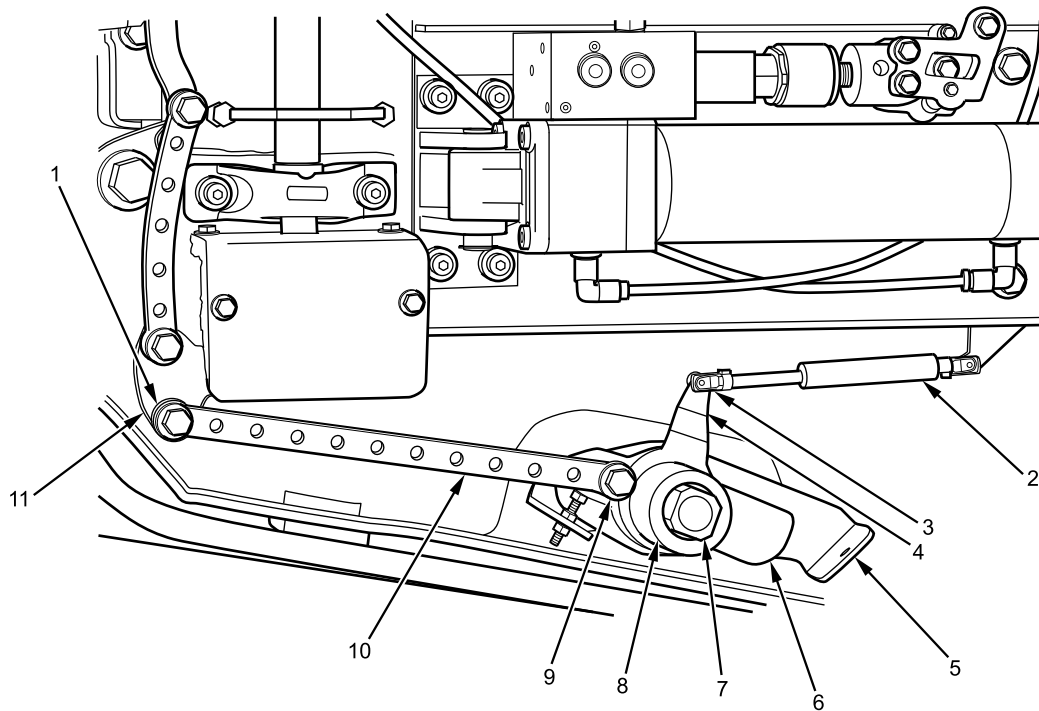

B231800748

Figure 3. Door Combat Lock Assembly Installation.

4. Install combat lock two-bolt retainer on inside door-mounted weld nuts with two socket head shouldered screws. Snug two screws finger tight, but do not tighten securely. Allow combat lock release shaft (Figure 3, Item 7) to rotate freely.
5. Install spacer and combat lock switch lever (Figure 3, Item 6) on combat lock release shaft (Figure 3, Item 7).
6. Install inner end of combat lock shaft lever (Figure 3, Item 10) on combat lock switch bracket (Figure 3, Item 5) with washer and hex bolt (Figure 3, Item 9).
7. Tighten inner hex bolt (Figure 3, Item 9) finger tight, but allow inner end of combat lock shaft lever (Figure 3, Item 10) to rotate freely on combat lock switch bracket (Figure 3, Item 5). Do not tighten hex bolt securely.
8. Tighten outer hex bolt (Figure 3, Item 1) finger tight, but allow outer end of lock shaft lever (Figure 3, Item 10) to rotate freely on combat lock bell crank (Figure 3, Item 11). Do not tighten hex bolt securely.
9. Install gas strut lever plate (Figure 3, Item 4) on combat lock release shaft (Figure 3, Item 7).
10. Connect gas strut (Figure 3, Item 2) to gas strut lever plate (Figure 3, Item 4) with clevis retaining clip (Figure 3, Item 3).
11. Install combat lock cylinder spacer (Figure 3, Item 8) on combat lock release shaft (Figure 3, Item 7).

END OF TASK

CABIN DOOR COMBAT LOCK ASSEMBLY REMOVAL AND INSTALLATION - (CONTINUED)**FOLLOW-ON MAINTENANCE**

1. Turn MAIN POWER switch on (TM 9-2355-106-10).
2. Start engine (TM 9-2355-106-10).
3. Refill air tanks (TM 9-2355-106-10).
4. Turn engine off (TM 9-2355-106-10).
5. Turn MAIN POWER switch off (TM 9-2355-106-10).
6. Verify inner door combat lock assembly for proper operation. Adjust lock assembly components as necessary to ensure combat lock works properly. (TM 9-2355-106-10).
7. Install cabin door trim panel (WP 0626 [Lower Combat Door Lock-Type]) or (WP 0627 [Upper Combat Door Lock-Type]).
8. Remove cabin door securing chain hoists and lifting strap (WP 0608).
9. Remove wheel chocks (TM 9-2355-106-10).

END OF TASK**END OF WORK PACKAGE**

FIELD MAINTENANCE

EXTERIOR BODY ARMOR RIGHT FRONT PANEL REMOVAL AND INSTALLATION

INITIAL SETUP:

Tools and Special Tools

General Mechanic's Tool Kit (GMTK)
(WP 0795, Item 37)

TM 9-2355-106-23P

WP 0786

WP 0782

Materials/Parts

Goggles, industrial (WP 0794, Item 20)
Faceshield, industrial (WP 0794, Item 16)
Compound (WP 0794, Item 13)
Gloves (WP 0794, Item 18)

Equipment Condition

Parking brake set (TM 9-2355-106-10)
Transmission set in NEUTRAL (N) (TM 9-2355-106-10)
Engine off (TM 9-2355-106-10)
MAIN POWER switch off (TM 9-2355-106-10)
Wheels chocked (TM 9-2355-106-10)
Right side cabin door open (TM 9-2355-106-10)
Exterior body armor riot guard removed (WP 0632)

Personnel Required

Maintainer - (2)

References

TM 9-2355-106-10

WARNING

Armor parts are heavy. Use care when removing or installing. Do not attempt to lift without an assistant or lifting device. Failure to comply may result in serious injury or death to personnel.

REMOVAL

1. With assistance, remove five bolts and washers (Figure 1, Item 1) from body armor right front panel (Figure 1, Item 2). Remove armor panel.

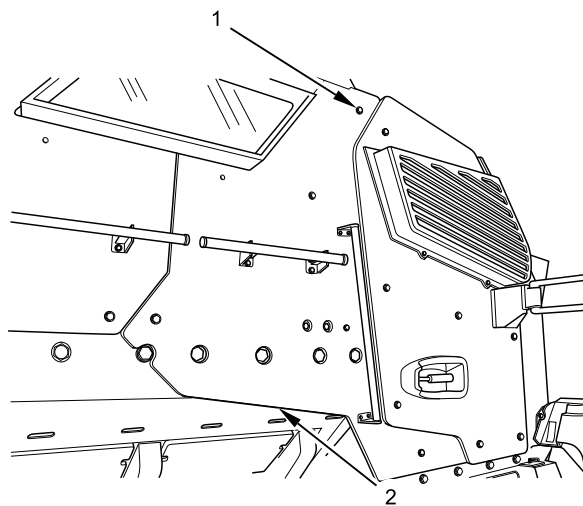

B230604943

Figure 1. Body Armor Right Front Panel.

EXTERIOR BODY ARMOR RIGHT FRONT PANEL REMOVAL AND INSTALLATION - (CONTINUED)

- Remove two bolts (Figure 2, Item 2) from each end of grab handle (Figure 2, Item 3). Remove grab handle.

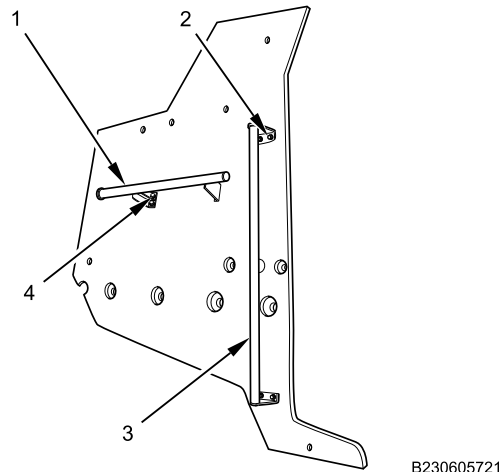

Figure 2. Handrail and Door Grab Handle.

- Remove two bolts (Figure 2, Item 4) from each end of handrail (Figure 2, Item 1). Remove handrail.

END OF TASK**INSTALLATION****WARNING**

Corrosion preventive compound is toxic. Use only in well-ventilated area. Do not get in eyes; wear chemical safety goggles and full-face shield when using. Avoid contact with skin and wear rubber or plastic, solvent-resistant gloves. In case of contact, remove contaminated clothing and immediately wash area with soap and water. If compound contacts eyes, flush eyes with large amounts of water for at least 15 minutes and get immediate medical attention. If swallowed, do not induce vomiting; contact a physician immediately. Failure to comply may result in serious injury or death to personnel.

NOTE

Apply corrosion preventive compound on all body armor right front panel mounting bolts.

- Install door grab handle (Figure 3, Item 3) on armor panel with four bolts (Figure 3, Item 2).

EXTERIOR BODY ARMOR RIGHT FRONT PANEL REMOVAL AND INSTALLATION - (CONTINUED)

Figure 3. Handrail and Door Grab Handle.

2. Install handrail (Figure 3, Item 1) on armor panel with four bolts (Figure 3, Item 4).
3. With assistance, install panel (Figure 4, Item 2) with five bolts and washers (Figure 4, Item 1). Tighten bolts securely.

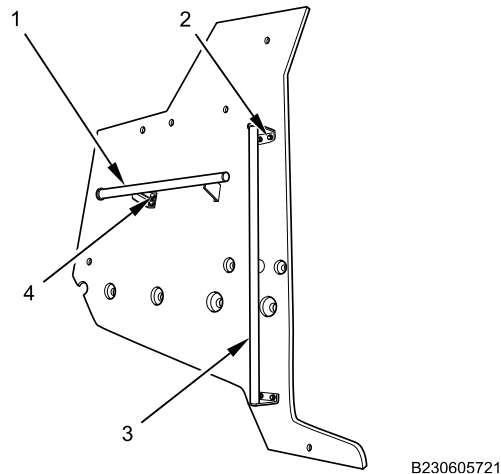
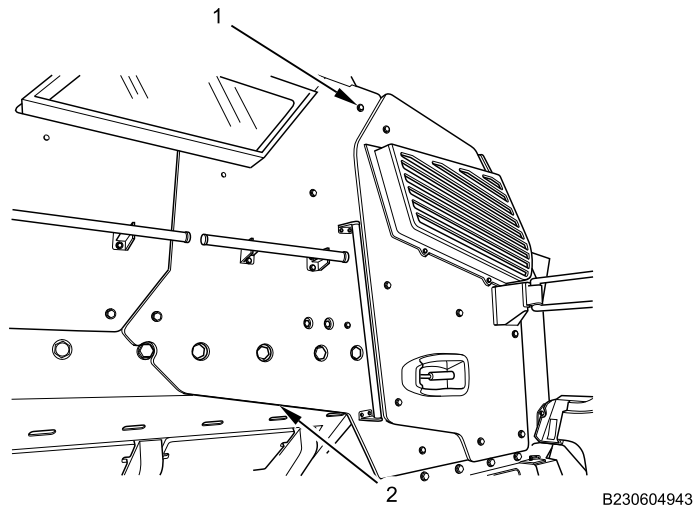

Figure 4. Body Armor Right Front Panel.

END OF TASK**FOLLOW-ON MAINTENANCE**

1. Install exterior body armor riot guard (WP 0632).
2. Close right side cabin door (TM 9-2355-106-10).
3. Remove wheel chocks (TM 9-2355-106-10).

END OF TASK**END OF WORK PACKAGE**

FIELD MAINTENANCE**EXTERIOR BODY ARMOR MIDDLE REAR PANEL REMOVAL AND INSTALLATION**

INITIAL SETUP:**Tools and Special Tools**

General Mechanic's Tool Kit (GMTK)
(WP 0795, Item 37)
Lifting device (WP 0795, Item 67)

Materials/Parts

Compound (WP 0794, Item 13)
Goggles, industrial (WP 0794, Item 20)
Faceshield, industrial (WP 0794, Item 16)
Gloves (WP 0794, Item 18)
Gloves (WP 0794, Item 19)

Personnel Required

Maintainer - (2)

References

TM 9-2355-106-10
TM 9-2355-106-23P
WP 0786
WP 0782

Equipment Condition

Parking brake set (TM 9-2355-106-10)
Transmission set in NEUTRAL (N) (TM 9-2355-106-10)
Engine off (TM 9-2355-106-10)
MAIN POWER switch off (TM 9-2355-106-10)
Wheels chocked (TM 9-2355-106-10)
Exterior body armor riot guard removed (WP 0632)

WARNING

Armor parts are heavy. Use care when removing or installing. Do not attempt to lift without an assistant and lifting device. Wear gloves. Failure to comply may result in serious injury or death to personnel.

Armor plate weighs approximately 100-120 lbs. Secure plate before removal of final bolt to prevent plate from falling. Failure to comply may result in damage to equipment and serious injury or death to personnel.

NOTE

This procedure is the same for right side of vehicle. Left side procedure shown.

EXTERIOR BODY ARMOR MIDDLE REAR PANEL REMOVAL AND INSTALLATION - (CONTINUED)**REMOVAL**

1. Remove two bolts and washers (Figure 1, Item 2) from lower ladder step (Figure 1, Item 3). Remove step.

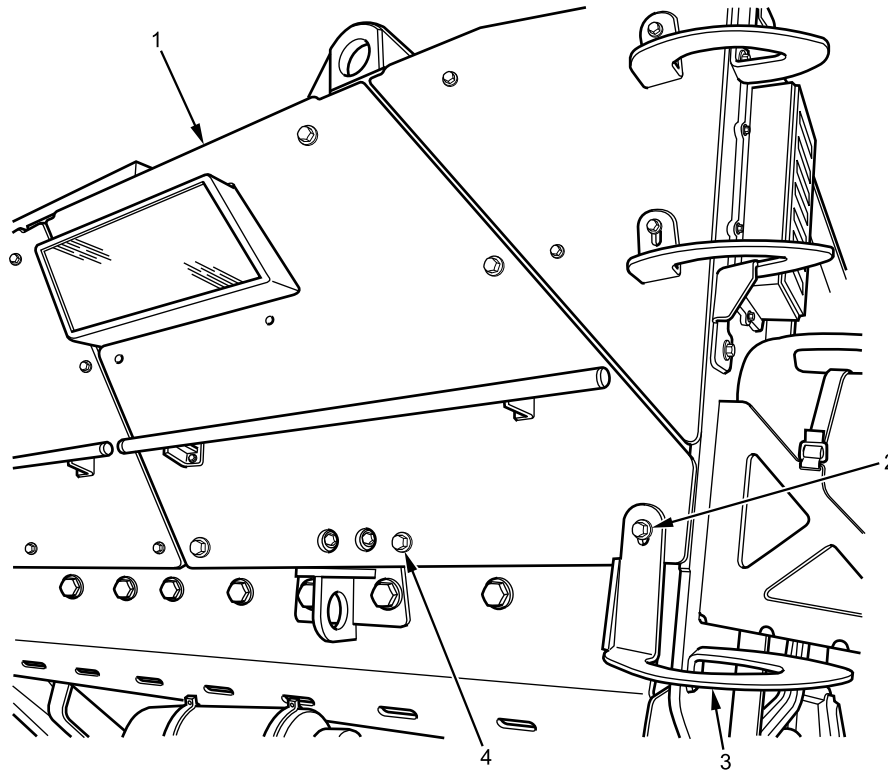

B231801886

Figure 1. Body Armor Middle Rear Panel.

2. With assistant, remove four bolts and washers (Figure 1, Item 4) from body armor middle rear panel (Figure 1, Item 1). Remove armor panel.

END OF TASK

EXTERIOR BODY ARMOR MIDDLE REAR PANEL REMOVAL AND INSTALLATION - (CONTINUED)**DISASSEMBLY**

1. Remove two bolts and washers (Figure 2, Item 2) from each end of handrail (Figure 2, Item 1). Remove handrail.

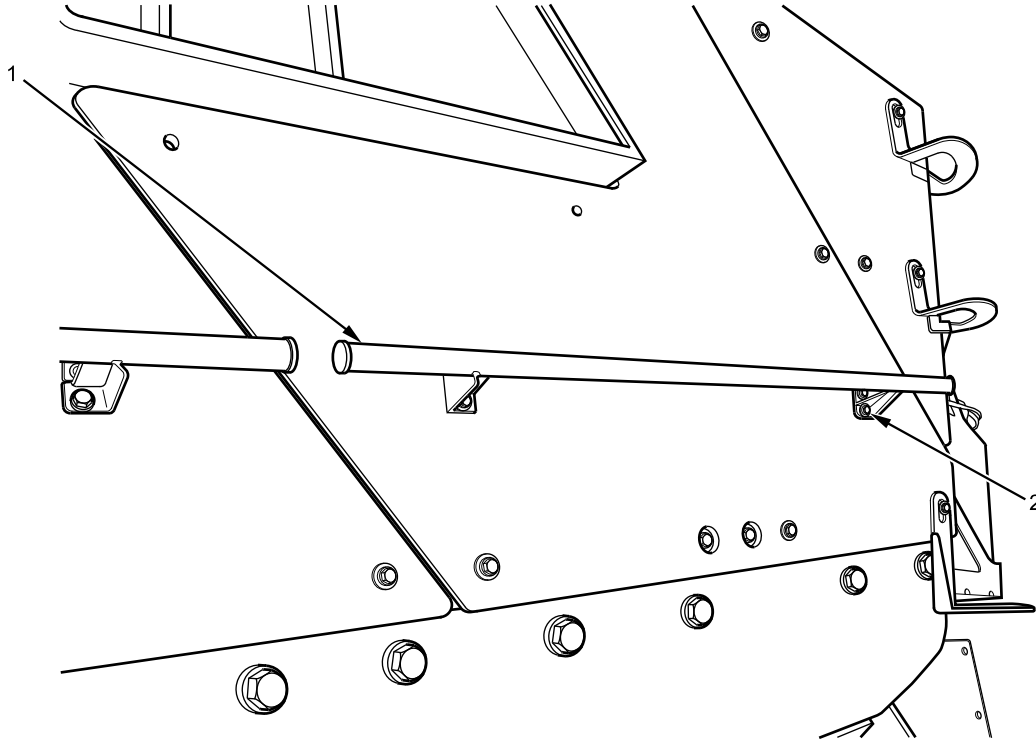

B231801887

Figure 2. Hand Rail.

END OF TASK

EXTERIOR BODY ARMOR MIDDLE REAR PANEL REMOVAL AND INSTALLATION - (CONTINUED)**ASSEMBLY**

1. Install handrail (Figure 3, Item 1) on armor panel with four bolts and washers (Figure 3, Item 2).

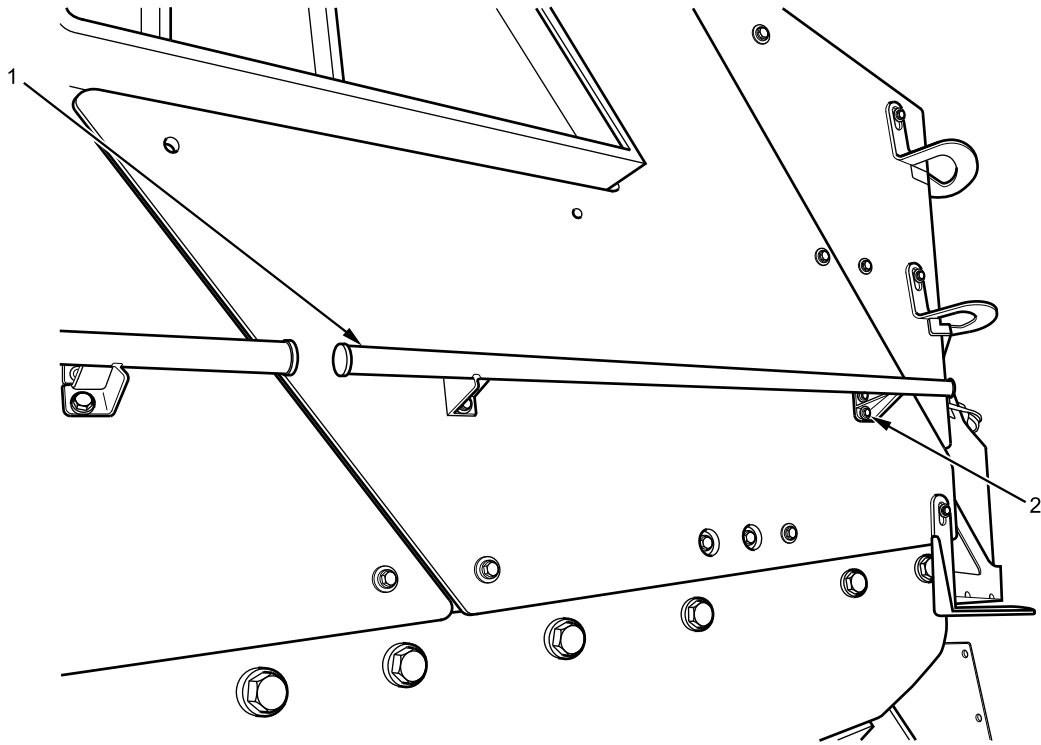

B231801887

Figure 3. Hand Rail.

END OF TASK

EXTERIOR BODY ARMOR MIDDLE REAR PANEL REMOVAL AND INSTALLATION - (CONTINUED)

INSTALLATION

WARNING



Antiseize compound can cause skin, eye, and respiratory irritation. Inhalation can cause difficulty breathing, dizziness, headache, and nausea. Wear eye protection and use only with adequate ventilation. Do not use near heat, sparks, or open flame. Wash hands and eyes after using compound. In case of skin contact, wash affected area with soap and water, and seek medical attention if irritation persists. If compound contacts eyes, flush eyes with water for at least 15 minutes, and obtain medical attention if irritation persists. In case of accidental ingestion, do not induce vomiting. Slowly drink 1-2 glasses of water or milk, and seek medical attention. Store compound in a closed container away from heat. Dispose of it in accordance with standard operating procedures. Failure to comply may result in injury to personnel.

1. Apply antiseize compound on four middle rear body armor panel mounting bolts (Figure 4, Item 4).

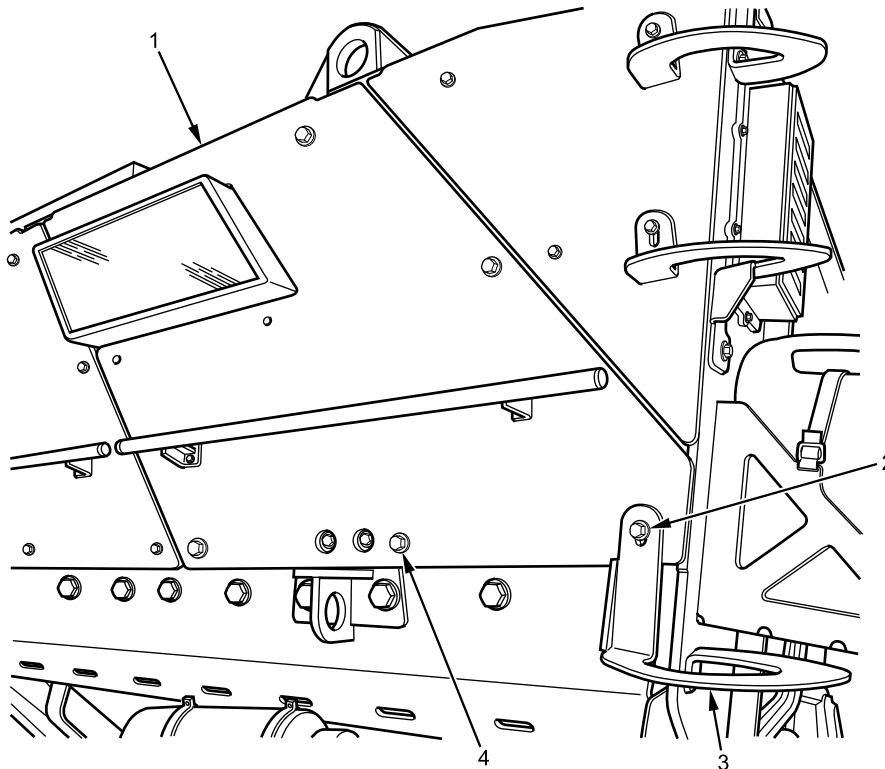

B231801886

Figure 4. Body Armor Middle Rear Panel.

2. With assistant, install middle rear body armor panel (Figure 4, Item 1) with four bolts and washers (Figure 4, Item 4). Tighten bolts securely.
3. Apply antiseize compound on two lower ladder step mounting bolts (Figure 4, Item 2).

EXTERIOR BODY ARMOR MIDDLE REAR PANEL REMOVAL AND INSTALLATION - (CONTINUED)

4. Install lower ladder step (Figure 4, Item 3) with two bolts and washers (Figure 4, Item 2). Tighten bolts securely.

END OF TASK**FOLLOW-ON MAINTENANCE**

1. Install exterior body armor riot guard (WP 0632).
2. Remove wheel chocks (TM 9-2355-106-10).

END OF TASK**END OF WORK PACKAGE**

FIELD MAINTENANCE**EXTERIOR BODY ARMOR REAR PANEL REMOVAL AND INSTALLATION**

INITIAL SETUP:**Tools and Special Tools**

General Mechanic's Tool Kit (GMTK)
(WP 0795, Item 37)
Lifting device (WP 0795, Item 67)

Materials/Parts

Compound (WP 0794, Item 13)
Goggles, industrial (WP 0794, Item 20)
Faceshield, industrial (WP 0794, Item 16)
Gloves (WP 0794, Item 18)
Gloves (WP 0794, Item 19)

Personnel Required

Maintainer - (2)

References

TM 9-2355-106-10
TM 9-2355-106-23P
WP 0786
WP 0782

Equipment Condition

Parking brake set (TM 9-2355-106-10)
Transmission set in NEUTRAL (N) (TM 9-2355-106-10)
Engine off (TM 9-2355-106-10)
MAIN POWER switch off (TM 9-2355-106-10)
Wheels chocked (TM 9-2355-106-10)

WARNING

Armor parts are heavy. Use care when removing or installing. Do not attempt to lift without an assistant and lifting device. Wear gloves. Failure to comply may result in serious injury or death to personnel.

NOTE

This procedure is the same for right side of vehicle. Left side procedure shown.

An antenna bracket may need to be removed before the right side body armor rear panel is removed. Ensure antenna bracket is installed after rear armor panel is installed.

EXTERIOR BODY ARMOR REAR PANEL REMOVAL AND INSTALLATION - (CONTINUED)**REMOVAL**

1. Remove two bolts (Figure 1, Item 3) from upper ladder step (Figure 1, Item 4). Remove ladder step.

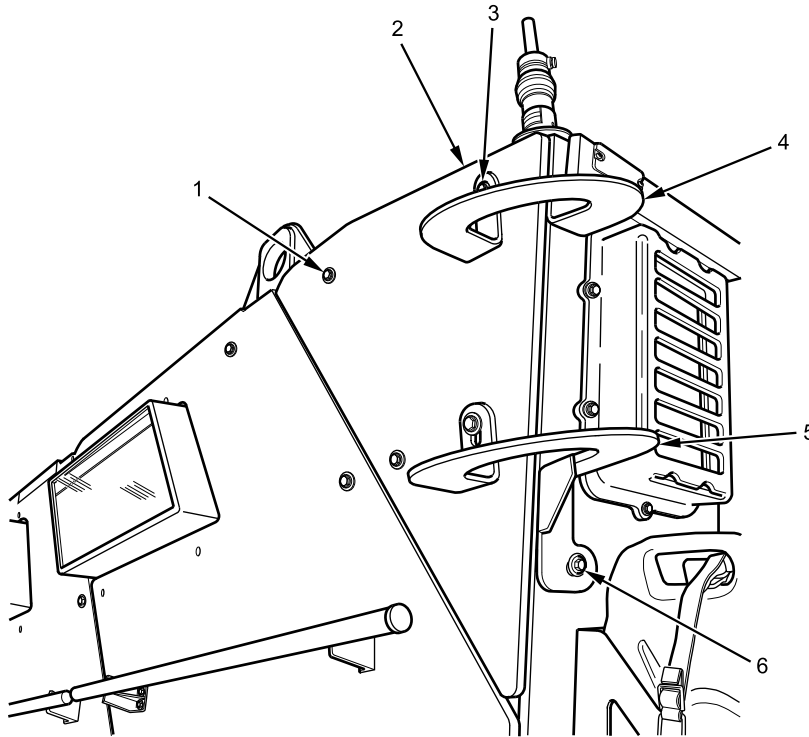

B231801885

Figure 1. Body Armor Rear Panel.

2. Remove two bolts (Figure 1, Item 6) from middle ladder step (Figure 1, Item 5). Remove middle step.
3. With assistant, remove two bolts and washers (Figure 1, Item 1) from body armor rear panel (Figure 1, Item 2). Remove armor panel.

END OF TASK**INSTALLATION****WARNING**

Corrosion preventive compound is toxic. Use only in well-ventilated area. Do not get in eyes; wear chemical safety goggles and full-face shield when using. Avoid contact with skin and wear rubber or plastic, solvent-resistant gloves. In case of contact, remove contaminated clothing and immediately wash area with soap and water. If compound contacts eyes, flush eyes with large amounts of water for at least 15 minutes and get immediate medical attention. If swallowed, do not induce vomiting; contact a physician immediately. Failure to comply may result in serious injury or death to personnel.

EXTERIOR BODY ARMOR REAR PANEL REMOVAL AND INSTALLATION - (CONTINUED)

1. Apply corrosion preventive compound on two body armor rear panel mounting bolts (Figure 2, Item 1).

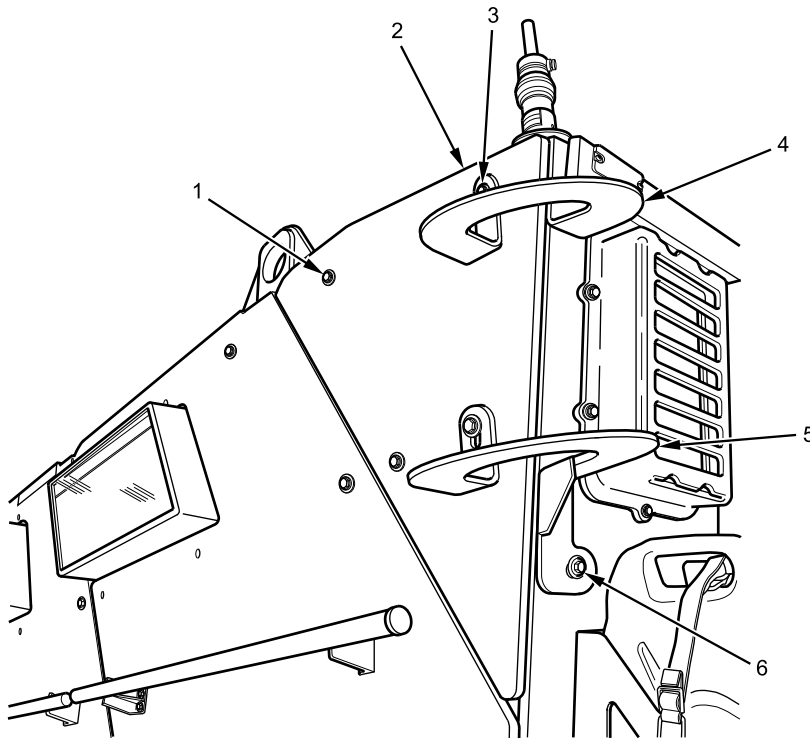

B231801885

Figure 2. Body Armor Rear Panel.

2. With assistant, install body armor rear panel (Figure 2, Item 2) with two bolts and washers (Figure 2, Item 1). Tighten bolts securely.
3. Apply corrosion preventive compound on two middle ladder step bolts (Figure 2, Item 6).
4. Install middle ladder step (Figure 2, Item 5) with two bolts and washers (Figure 2, Item 6). Tighten bolts securely.
5. Apply corrosion preventive compound on two upper ladder step bolts (Figure 2, Item 3).
6. Install upper ladder step (Figure 2, Item 4) with two bolts and washers (Figure 2, Item 3). Tighten bolts securely.

END OF TASK**FOLLOW-ON MAINTENANCE**

1. Remove wheel chocks (TM 9-2355-106-10).

END OF TASK**END OF WORK PACKAGE**

FIELD MAINTENANCE

EXTERIOR BODY ARMOR RIOT GUARD REMOVAL AND INSTALLATION

INITIAL SETUP:

Tools and Special Tools

General Mechanic's Tool Kit (GMTK)
(WP 0795, Item 37)

WP 0786

WP 0782

Equipment Condition

Parking brake set (TM 9-2355-106-10)

Transmission set in NEUTRAL (N) (TM
9-2355-106-10)

Engine off (TM 9-2355-106-10)

MAIN POWER switch off (TM 9-2355-106-10)

Wheels chocked (TM 9-2355-106-10)

Personnel Required

Maintainer - (2)

References

TM 9-2355-106-10

TM 9-2355-106-23P

NOTE

This procedure is the same for left and right side exterior body armor riot guards. Left side procedure shown.

REMOVAL

WARNING



Secure guard before removal of final bolt to prevent guard from falling. Failure to comply may result in damage to equipment and serious injury or death to personnel.

1. With assistant, remove four bolts (Figure 1, Item 2) and washers (Figure 1, Item 1) from window riot guard (Figure 1, Item 3) on side armor panel (Figure 1, Item 4). Remove window riot guard.

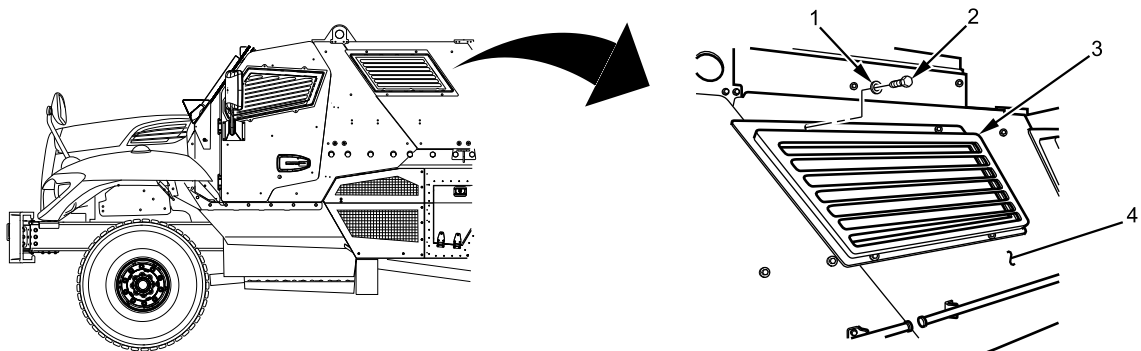

B231810566

Figure 1. Exterior Body Armor Riot Guard.

END OF TASK

EXTERIOR BODY ARMOR RIOT GUARD REMOVAL AND INSTALLATION - (CONTINUED)**INSTALLATION**

1. With assistant, install window riot guard (Figure 2, Item 3) on side armor panel (Figure 2, Item 4) with four bolts (Figure 2, Item 2) and washers (Figure 2, Item 1). Tighten bolts securely.

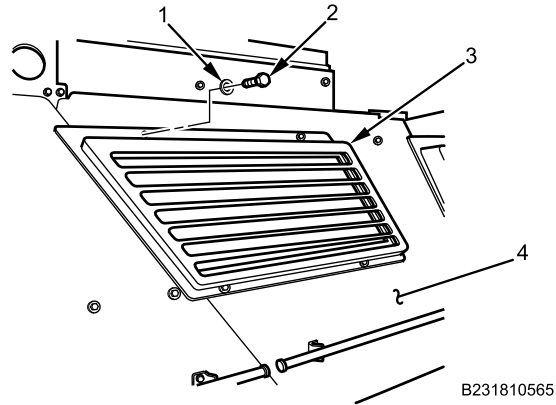

Figure 2. Exterior Body Armor Riot Guard.

END OF TASK**FOLLOW-ON MAINTENANCE**

1. Remove wheel chocks (TM 9-2355-106-10).

END OF TASK**END OF WORK PACKAGE**

FIELD MAINTENANCE

EXTERIOR BODY ARMOR LEFT FRONT PANEL REMOVAL AND INSTALLATION

INITIAL SETUP:

Tools and Special Tools

General Mechanic's Tool Kit (GMTK)
(WP 0795, Item 37)
Lifting device (WP 0795, Item 67)
Lifting sling (WP 0795, Item 68)

Materials/Parts

Compound (WP 0794, Item 13)
Goggles, industrial (WP 0794, Item 20)
Faceshield, industrial (WP 0794, Item 16)
Gloves (WP 0794, Item 18)
Gloves (WP 0794, Item 19)

Personnel Required

Maintainer - (2)

References

TM 9-2355-106-10
TM 9-2355-106-23P
WP 0786
WP 0782

Equipment Condition

Parking brake set (TM 9-2355-106-10)
Transmission set in NEUTRAL (N) (TM 9-2355-106-10)
Engine off (TM 9-2355-106-10)
MAIN POWER switch off (TM 9-2355-106-10)
Wheels chocked (TM 9-2355-106-10)
Exterior body armor riot guard removed (WP 0632)

WARNING

Armor parts are heavy. Use care when removing or installing. Do not attempt to lift without an assistant and lifting device. Wear gloves. Failure to comply may result in serious injury or death to personnel.

REMOVAL

1. Secure lifting sling to body armor left front panel (Figure 1, Item 2) and attach sling to lifting device.

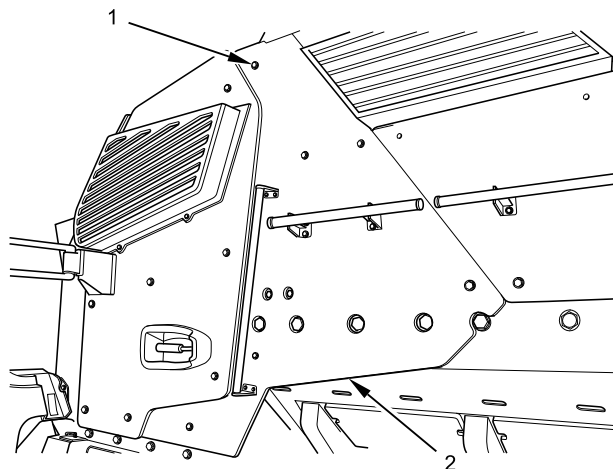

B231801891

Figure 1. Body Armor Left Front Panel.

2. With assistant, remove six bolts and washers (Figure 1, Item 1) from body armor left front panel (Figure 1, Item 2). Remove armor panel.

END OF TASK

EXTERIOR BODY ARMOR LEFT FRONT PANEL REMOVAL AND INSTALLATION - (CONTINUED)**DISASSEMBLY**

1. Remove sling from body armor left front panel.

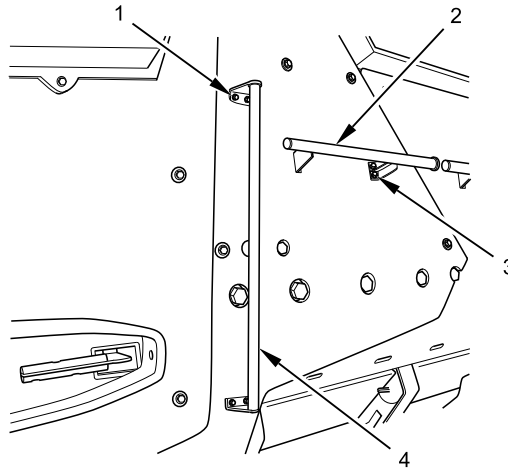

B231801890

Figure 2. Door Grab Handle.

2. Remove two bolts (Figure 2, Item 1) from each end of grab handle (Figure 2, Item 4). Remove grab handle.
3. Remove two bolts and washers (Figure 2, Item 3) from each end of handrail (Figure 2, Item 2). Remove handrail.

END OF TASK**ASSEMBLY**

1. Install door grab handle (Figure 3, Item 4) on armor panel with four bolts and washers (Figure 3, Item 1).

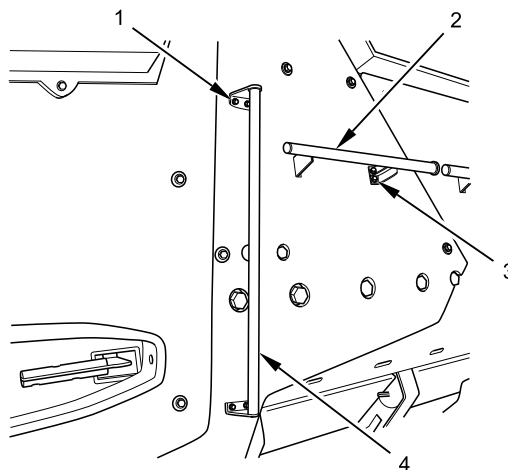

B231801890

Figure 3. Door Grab Handle.

2. Install handrail (Figure 3, Item 2) on armor panel with four bolts and washers (Figure 3, Item 3).

END OF TASK

EXTERIOR BODY ARMOR LEFT FRONT PANEL REMOVAL AND INSTALLATION - (CONTINUED)**INSTALLATION****WARNING**

Corrosion preventive compound is toxic. Use only in well-ventilated area. Do not get in eyes; wear chemical safety goggles and full-face shield when using. Avoid contact with skin and wear rubber or plastic, solvent-resistant gloves. In case of contact, remove contaminated clothing and immediately wash area with soap and water. If compound contacts eyes, flush eyes with large amounts of water for at least 15 minutes and get immediate medical attention. If swallowed, do not induce vomiting; contact a physician immediately. Failure to comply may result in serious injury or death to personnel.

1. Apply corrosion preventive compound on six body armor left front panel mounting bolts (Figure 4, Item 1).

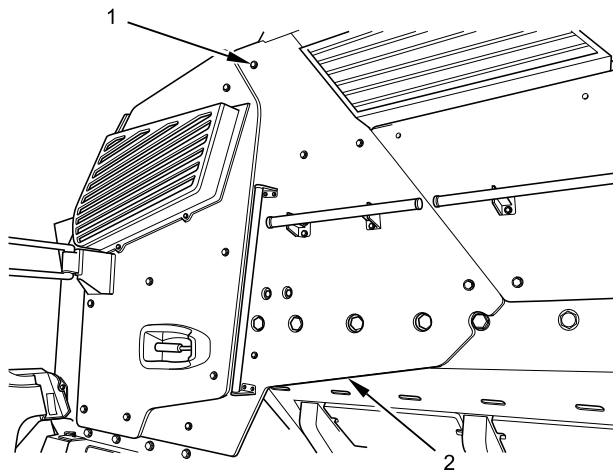

B231801891

Figure 4. Body Armor Left Front Panel.

2. With assistant, attach sling to body armor left front panel (Figure 4, Item 2) and install panel with six bolts and washers (Figure 4, Item 1). Tighten bolts securely.

END OF TASK**FOLLOW-ON MAINTENANCE**

1. Install exterior body armor riot guard (WP 0632).
2. Remove wheel chocks (TM 9-2355-106-10).

END OF TASK**END OF WORK PACKAGE**

FIELD MAINTENANCE

EXTERIOR BODY ARMOR LEFT MIDDLE FRONT PANEL REMOVAL AND INSTALLATION

INITIAL SETUP:

Tools and Special Tools

General Mechanic's Tool Kit (GMTK)
(WP 0795, Item 37)
Lifting device (WP 0795, Item 67)

TM 9-2355-106-23P

WP 0786

WP 0782

Materials/Parts

Compound (WP 0794, Item 13)
Goggles, industrial (WP 0794, Item 20)
Faceshield, industrial (WP 0794, Item 16)
Gloves (WP 0794, Item 18)
Gloves (WP 0794, Item 19)

Equipment Condition

Parking brake set (TM 9-2355-106-10)
Transmission set in NEUTRAL (N) (TM
9-2355-106-10)
Engine off (TM 9-2355-106-10)
MAIN POWER switch off (TM 9-2355-106-10)
Wheels chocked (TM 9-2355-106-10)
Front and rear left exterior body armor riot guards
removed (WP 0632)

Personnel Required

Maintainer - (2)

References

TM 9-2355-106-10

WARNING

Armor parts are heavy. Use care when removing or installing. Do not attempt to lift without an assistant and lifting device. Wear gloves. Failure to comply may result in serious injury or death to personnel.

REMOVAL

1. With assistant, remove five bolts and washers (Figure 1, Item 2) from body armor left middle front panel (Figure 1, Item 1). Remove armor panel.

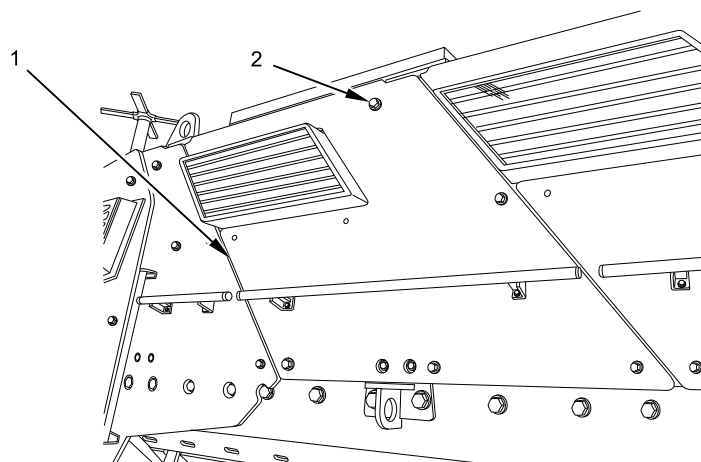

B231801888

Figure 1. Body Armor Left Middle Front Panel.

END OF TASK

EXTERIOR BODY ARMOR LEFT MIDDLE FRONT PANEL REMOVAL AND INSTALLATION - (CONTINUED)

DISASSEMBLY

1. Remove two bolts (Figure 2, Item 2) from each end of handrail (Figure 2, Item 1). Remove handrail.

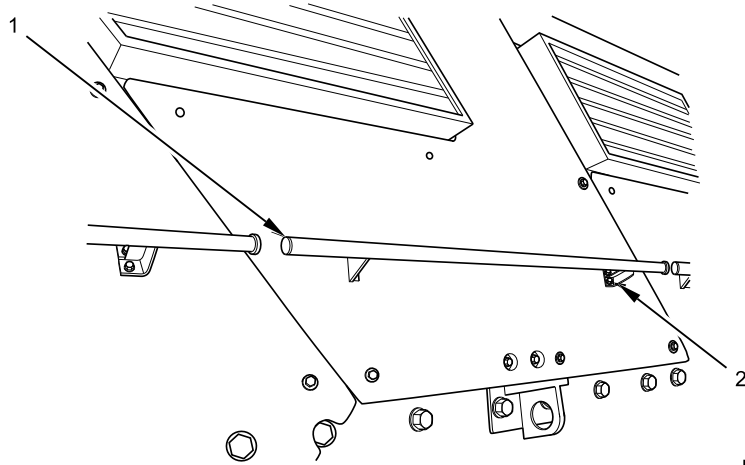

B231801889

Figure 2. Hand Rail.

END OF TASK

ASSEMBLY

1. Install handrail (Figure 3, Item 1) on armor panel with four bolts and washers (Figure 3, Item 2).

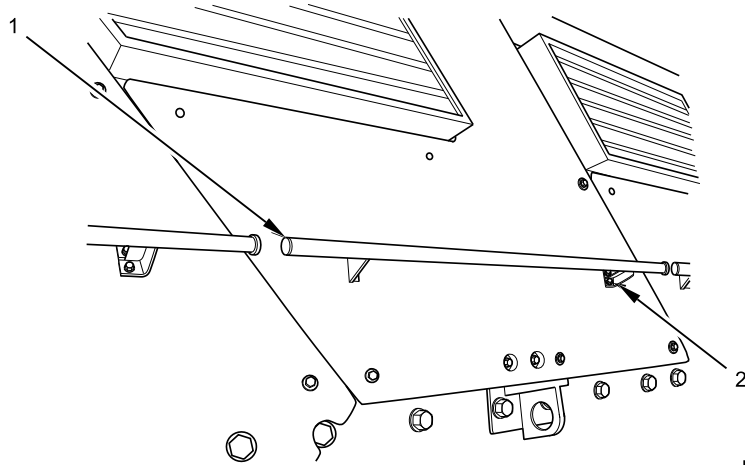

B231801889

Figure 3. Hand Rail.

END OF TASK

EXTERIOR BODY ARMOR LEFT MIDDLE FRONT PANEL REMOVAL AND INSTALLATION - (CONTINUED)

INSTALLATION

WARNING



Antiseize compound can cause skin, eye, and respiratory irritation. Inhalation can cause difficulty breathing, dizziness, headache, and nausea. Wear eye protection and use only with adequate ventilation. Do not use near heat, sparks, or open flame. Wash hands and eyes after using compound. In case of skin contact, wash affected area with soap and water, and seek medical attention if irritation persists. If compound contacts eyes, flush eyes with water for at least 15 minutes, and obtain medical attention if irritation persists. In case of accidental ingestion, do not induce vomiting. Slowly drink 1-2 glasses of water or milk, and seek medical attention. Store compound in a closed container away from heat. Dispose of it in accordance with standard operating procedures. Failure to comply may result in injury to personnel.

1. Apply antiseize compound on five body armor left middle front panel bolts (Figure 4, Item 2).

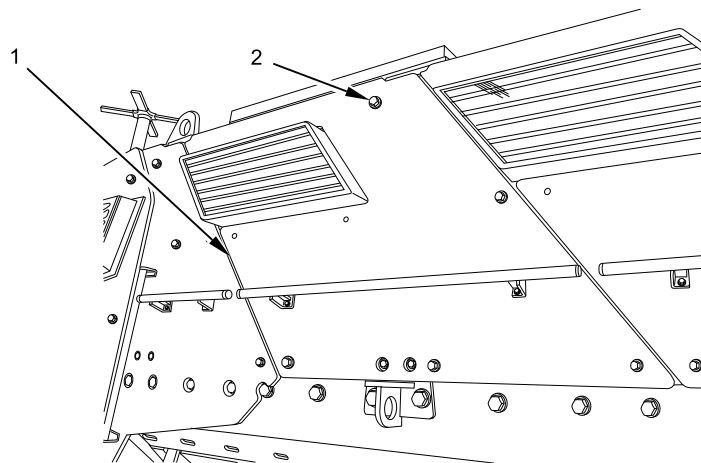

B231801888

Figure 4. Body Armor Left Middle Front Panel.

2. With assistant, position body armor left middle front panel (Figure 4, Item 1) and install panel with five bolts and washers (Figure 4, Item 2). Tighten bolts securely.

END OF TASK

EXTERIOR BODY ARMOR LEFT MIDDLE FRONT PANEL REMOVAL AND INSTALLATION - (CONTINUED)**FOLLOW-ON MAINTENANCE**

1. Install both exterior body armor riot guards (WP 0632).
2. Remove wheel chocks (TM 9-2355-106-10).

END OF TASK**END OF WORK PACKAGE**

FIELD MAINTENANCE

EXTERIOR BODY ARMOR RIGHT MIDDLE FRONT PANEL REMOVAL AND INSTALLATION

INITIAL SETUP:

Tools and Special Tools

General Mechanic's Tool Kit (GMTK)
(WP 0795, Item 37)
Lifting device (WP 0795, Item 67)

TM 9-2355-106-23P

WP 0782

Equipment Condition

Parking brake set (TM 9-2355-106-10)
Wheels chocked (TM 9-2355-106-10)
Transmission set in NEUTRAL (N) (TM
9-2355-106-10)
Engine off (TM 9-2355-106-10)
MAIN POWER switch off (TM 9-2355-106-10)
Both right cabin window riot guards removed
(WP 0632)

Materials/Parts

Compound (WP 0794, Item 6)
Goggles, industrial (WP 0794, Item 20)
Faceshield, industrial (WP 0794, Item 16)
Gloves (WP 0794, Item 18)

Personnel Required

Maintainer - (2)

References

TM 9-2355-106-10

WARNING

Armor parts are heavy. Use care when removing or installing. Do not attempt to lift without an assistant and lifting device. Failure to comply may result in serious injury or death to personnel.

REMOVAL

1. With assistance, remove five bolts, washers (Figure 1, Item 2), and body armor right middle front panel (Figure 1, Item 1) from vehicle.

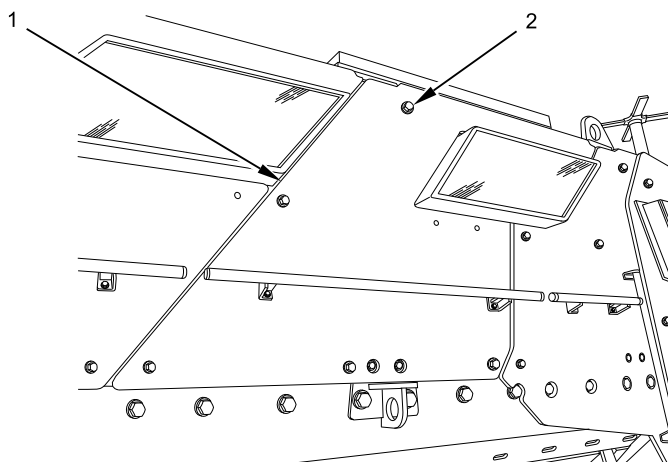

B231803083

Figure 1. Body Armor Right Middle Front Panel.

END OF TASK

EXTERIOR BODY ARMOR RIGHT MIDDLE FRONT PANEL REMOVAL AND INSTALLATION - (CONTINUED)**DISASSEMBLY**

1. Remove four bolts, washers (Figure 2, Item 3), and handrail (Figure 2, Item 1) from armor right middle front panel (Figure 2, Item 2).

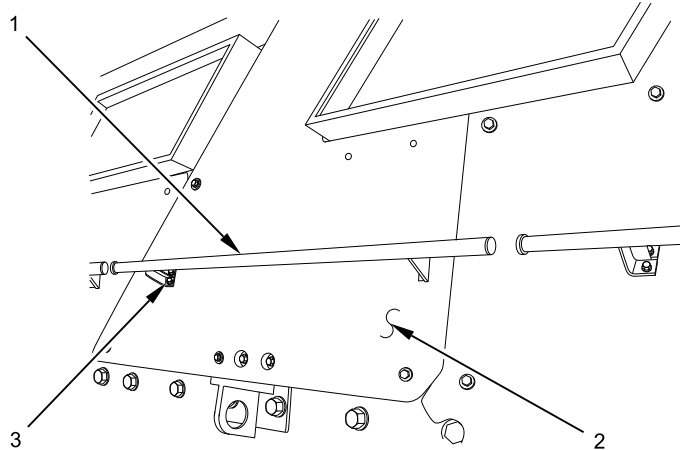

B231803084

Figure 2. Hand Rail.

END OF TASK**ASSEMBLY**

1. Install handrail (Figure 3, Item 1) on armor right middle front panel (Figure 3, Item 2) with four bolts and washers (Figure 3, Item 3).

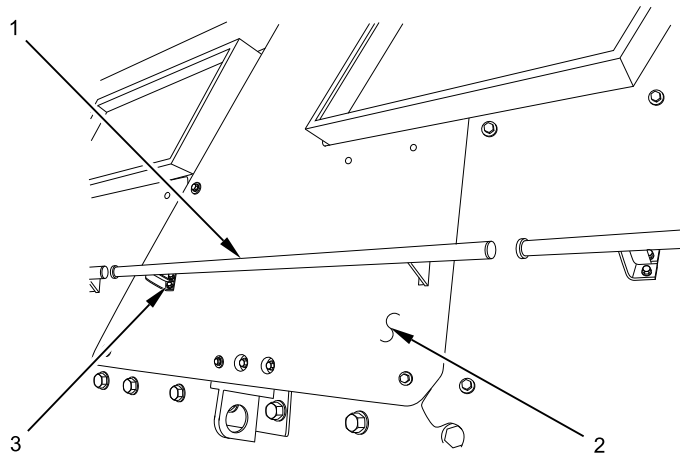

B231803084

Figure 3. Hand Rail.

END OF TASK

EXTERIOR BODY ARMOR RIGHT MIDDLE FRONT PANEL REMOVAL AND INSTALLATION - (CONTINUED)

INSTALLATION

WARNING



Antiseize compound can cause skin, eye, and respiratory irritation. Inhalation can cause difficulty breathing, dizziness, headache, and nausea. Wear eye protection and use only with adequate ventilation. Do not use near heat, sparks, or open flame. Wash hands and eyes after using compound. In case of skin contact, wash affected area with soap and water, and seek medical attention if irritation persists. If compound contacts eyes, flush eyes with water for at least 15 minutes, and obtain medical attention if irritation persists. In case of accidental ingestion, do not induce vomiting. Slowly drink 1-2 glasses of water or milk, and seek medical attention. Store compound in a closed container away from heat. Dispose of it in accordance with standard operating procedures. Failure to comply may result in injury to personnel.

1. Apply antiseize compound on five bolt threads (Figure 4, Item 2).

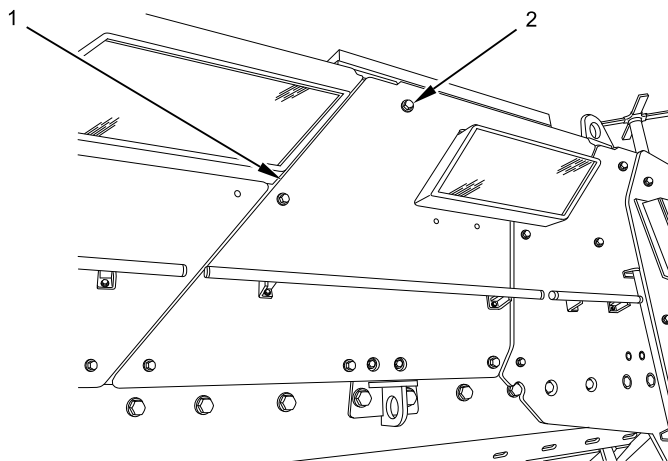

B231803083

Figure 4. Body Armor Right Middle Front Panel.

2. With assistance, position body armor right middle front panel (Figure 4, Item 1) on vehicle and install panel with five bolts and washers (Figure 4, Item 2). Tighten bolts securely.

END OF TASK

EXTERIOR BODY ARMOR RIGHT MIDDLE FRONT PANEL REMOVAL AND INSTALLATION - (CONTINUED)**FOLLOW-ON MAINTENANCE**

1. Install both cabin window riot guards (WP 0632).
2. Remove wheel chocks (TM 9-2355-106-10).

END OF TASK**END OF WORK PACKAGE**

FIELD MAINTENANCE

REAR DOOR/RAMP SEAL REMOVAL AND INSTALLATION

INITIAL SETUP:

Tools and Special Tools

General Mechanic's Tool Kit (GMTK)
(WP 0795, Item 37)
Knife, utility, retractable (WP 0795, Item 65)

Materials/Parts

Goggles, industrial (WP 0794, Item 20)
Gloves (WP 0794, Item 18)
Rag (WP 0794, Item 39)
Adhesive (WP 0794, Item 4)

References

TM 9-2355-106-10

TM 9-2355-106-23P

WP 0782

Equipment Condition

Parking brake set (TM 9-2355-106-10)
Transmission set in NEUTRAL (N) (TM 9-2355-106-10)
Engine off (TM 9-2355-106-10)
MAIN POWER switch off (TM 9-2355-106-10)
Wheels chocked (TM 9-2355-106-10)
Wheels chocked (TM 9-2355-106-10)

WARNING

Ensure no one is behind vehicle when lowering rear door/ramp. Use extreme caution when using emergency rear door/ramp release, to ensure no one is struck by door as it falls open. Sound horn before lowering door/ramp. Keep arms and legs clear of rear door/ramp when closing. Do not operate rear door/ramp when vehicle is in motion. Failure to comply may result in serious injury or death to personnel.

REMOVAL

1. Lower rear door/ramp assembly (Figure 1, Item 1) from closed position (TM 9-2355-106-10).

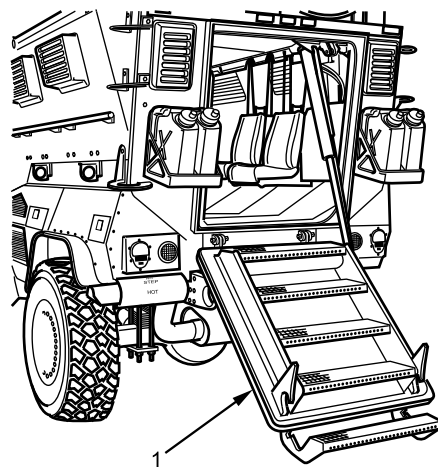

B231801603

Figure 1. Rear Door/Ramp Assembly Lowered.

2. Turn MAIN POWER switch off (TM 9-2355-106-10).

REAR DOOR/RAMP SEAL REMOVAL AND INSTALLATION - (CONTINUED)

3. Cut adhesive at seam (Figure 2, Item 2) of seal (Figure 2, Item 1) using a utility knife.

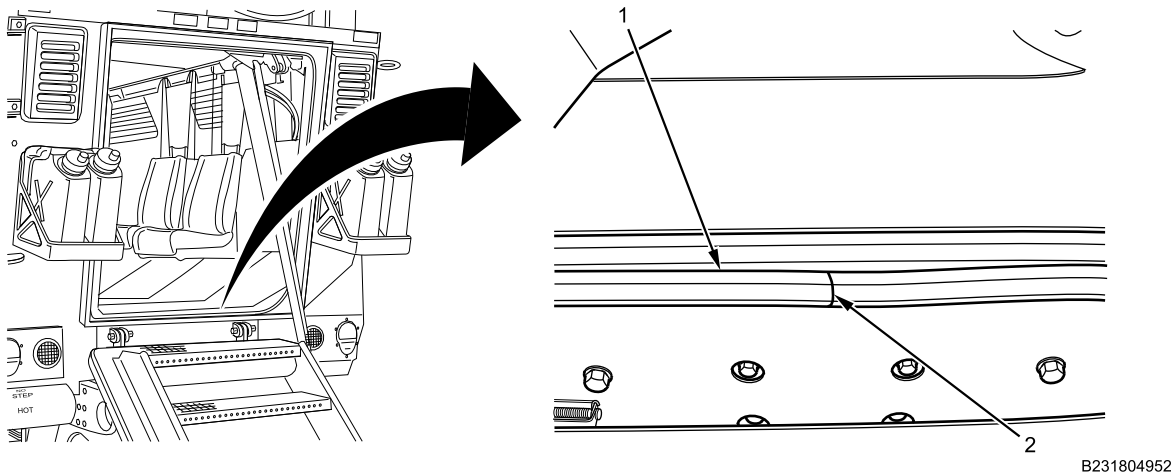

Figure 2. Rear Door/Ramp Seal Seam Adhesive Cut.

4. Starting at seam (Figure 3, Item 4), manually pull seal (Figure 3, Item 2) from retaining lip (Figure 3, Item 3) around door opening (Figure 3, Item 1).

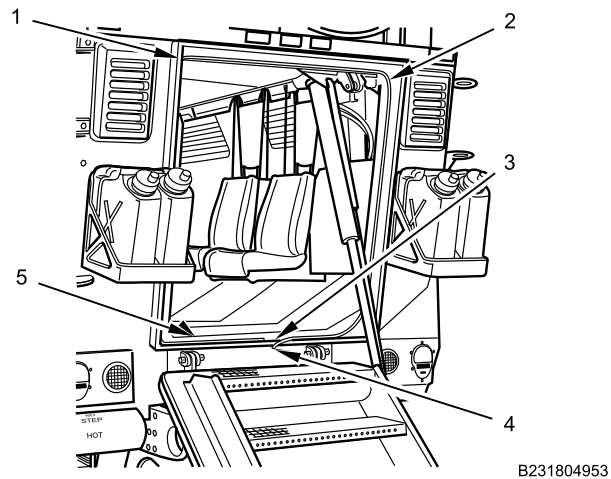

Figure 3. Rear Door/Ramp Seal Removal.

5. Clean dirt and debris from bottom of door opening (Figure 3, Item 5) using a rag.

END OF TASK

REAR DOOR/RAMP SEAL REMOVAL AND INSTALLATION - (CONTINUED)

INSTALLATION

WARNING



Adhesives, solvents, and sealing compounds can burn easily, can give off harmful vapors, and are harmful to skin and clothing. Wear goggles and protective clothing. Keep away from open flame and use in well-ventilated area. If adhesive, solvent, or sealing compound get on skin or clothing, wash immediately with soap and water. Failure to comply may result in injury or death to personnel.

1. Starting with seam (Figure 4, Item 4) at bottom middle of door opening (Figure 4, Item 1), install seal (Figure 4, Item 2) by manually pressing over retaining lip (Figure 4, Item 3).

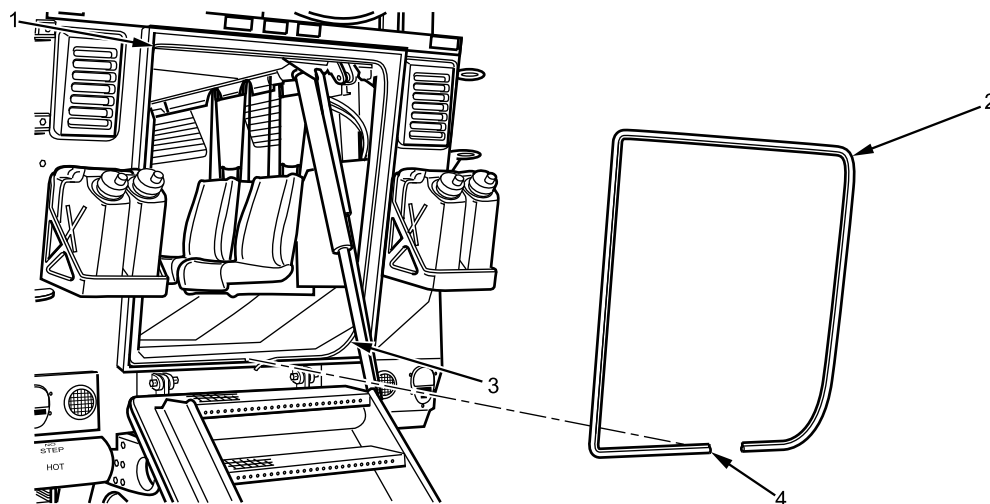

B231804954

Figure 4. Rear Door/Ramp Seal Installation.

2. Trim and discard excess seal (Figure 4, Item 2) with utility knife to make a tight fitting seam (Figure 5, Item 2).

REAR DOOR/RAMP SEAL REMOVAL AND INSTALLATION - (CONTINUED)

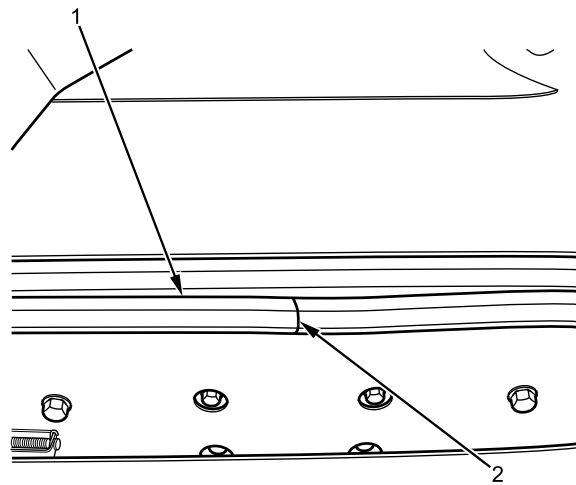

B231805270

Figure 5. Rear Door/Ramp Seal Seam Adhesive Application.

3. Apply adhesive to seam (Figure 5, Item 2) of seal (Figure 5, Item 1).
4. Allow 15 minutes for adhesive to dry before closing the rear door/ramp assembly.
5. Turn MAIN POWER switch on (TM 9-2355-106-10).
6. Raise rear door/ramp assembly (Figure 6, Item 1) to closed position (TM 9-2355-106-10).

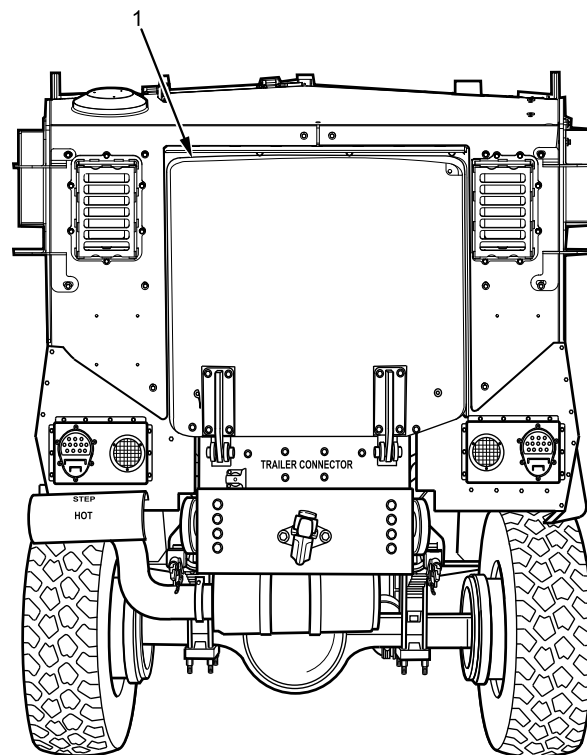

B231804955

Figure 6. Rear Door/Ramp Assembly Raised.

END OF TASK

REAR DOOR/RAMP SEAL REMOVAL AND INSTALLATION - (CONTINUED)**FOLLOW-ON MAINTENANCE**

1. Turn MAIN POWER switch off (TM 9-2355-106-10).
2. Remove wheel chocks (TM 9-2355-106-10).

END OF TASK**END OF WORK PACKAGE**

FIELD MAINTENANCE**BODY ARMOR REAR WALL, RIOT GUARD, AND BRACKET REMOVAL AND INSTALLATION**

INITIAL SETUP:**Tools and Special Tools**

General Mechanic's Tool Kit (GMTK)
(WP 0795, Item 37)

Materials/Parts

Goggles, industrial (WP 0794, Item 20)
Face shield, industrial (WP 0794, Item 16)
Gloves (WP 0794, Item 18)
Gloves (WP 0794, Item 19)
Compound (WP 0794, Item 13)
Locknut - (10) (WP 0796, Item 149)

Personnel Required

Maintainer - (2)

References

TM 9-2355-106-10
TM 9-2355-106-23P
WP 0786
WP 0782

Equipment Condition

Parking brake set (TM 9-2355-106-10)
Transmission set in NEUTRAL (N) (TM 9-2355-106-10)
Engine off (TM 9-2355-106-10)
MAIN POWER switch off (TM 9-2355-106-10)
Wheels chocked (TM 9-2355-106-10)
Rear door/ramp open (TM 9-2355-106-10)

WARNING

Armor parts are heavy. Use care when removing or installing. Do not attempt to lift without an assistant. Wear gloves. Failure to comply may result in serious injury or death to personnel.

NOTE

This procedure is the same for right rear wall armor. Left side procedure shown.

BODY ARMOR REAR WALL, RIOT GUARD, AND BRACKET REMOVAL AND INSTALLATION - (CONTINUED)

REMOVAL

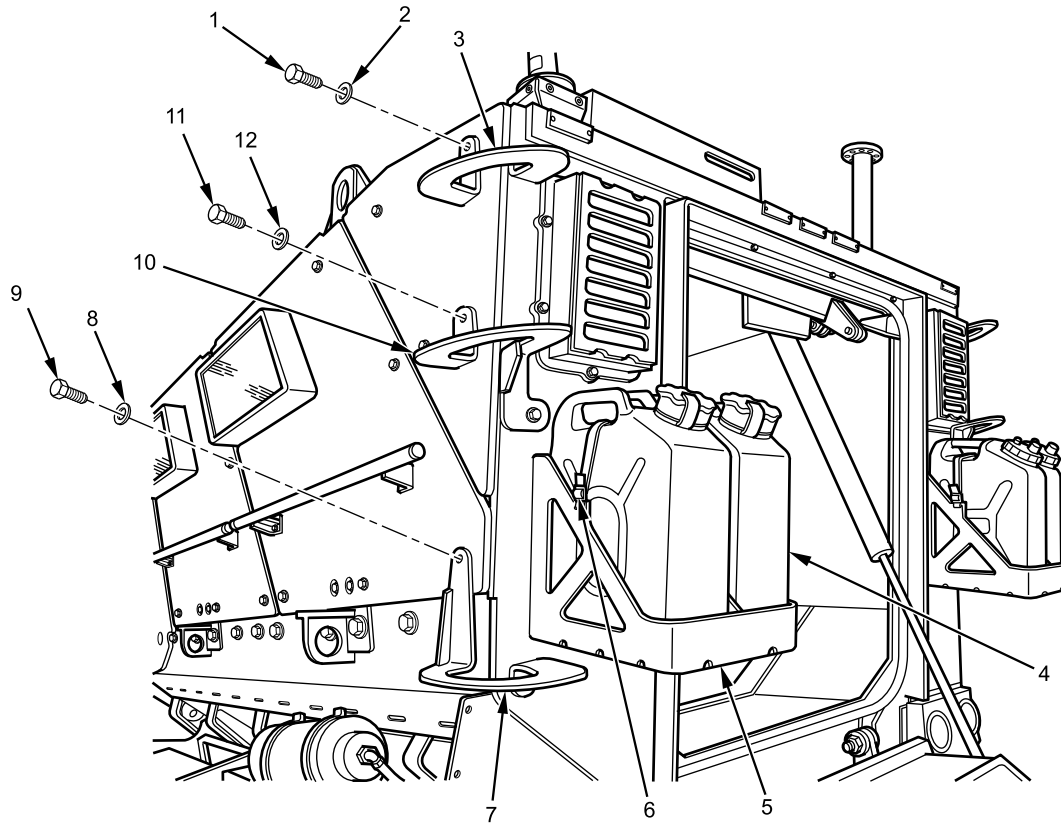

B231801897

Figure 1. Rear Ladder and Fuel/Water Cans.

1. Remove two bolts (Figure 1, Item 1) and washers (Figure 1, Item 2) from upper ladder step (Figure 1, Item 3). Remove step (Figure 1, Item 3).
2. Remove two bolts (Figure 1, Item 11) and washers (Figure 1, Item 12) from middle ladder step (Figure 1, Item 10). Remove step (Figure 1, Item 10).
3. Remove two bolts (Figure 1, Item 9) and washers (Figure 1, Item 8) from lower ladder step (Figure 1, Item 7). Remove step (Figure 1, Item 7).
4. Release holddown strap (Figure 1, Item 6) from fuel/water cans (Figure 1, Item 4) and remove cans (Figure 1, Item 4) from mount (Figure 1, Item 5).

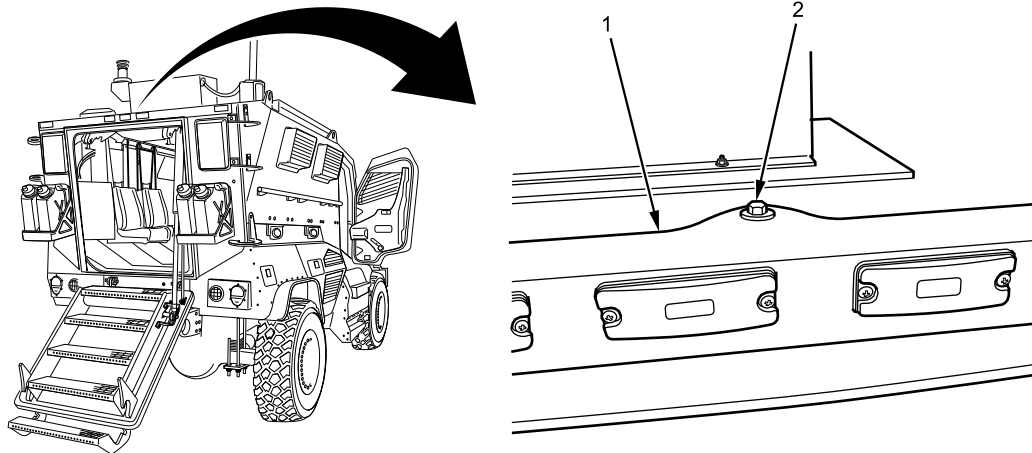
BODY ARMOR REAR WALL, RIOT GUARD, AND BRACKET REMOVAL AND INSTALLATION - (CONTINUED)

B231810712

Figure 2. Upper Light Bar, Above Rear Door.

5. Remove bolt (Figure 2, Item 2) from upper light bar (Figure 2, Item 1) and position light bar (Figure 2, Item 1) aside.
6. With assistant, remove four bolts and washers (Figure 3, Item 2) from left rear wall body armor panel (Figure 3, Item 1). Remove armor panel (Figure 3, Item 1).

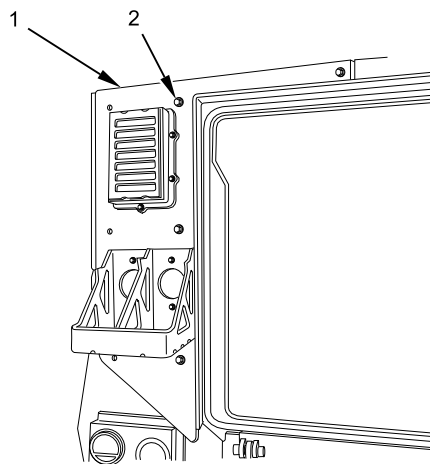

B231801908

Figure 3. Rear Wall Body Armor.

END OF TASK

BODY ARMOR REAR WALL, RIOT GUARD, AND BRACKET REMOVAL AND INSTALLATION - (CONTINUED)**DISASSEMBLY**

1. Remove six bolts (Figure 4, Item 3) and locknuts (Figure 4, Item 4) from rear window riot guard (Figure 4, Item 2) on armor panel (Figure 4, Item 1). Remove window riot guard (Figure 4, Item 2). Discard locknuts.

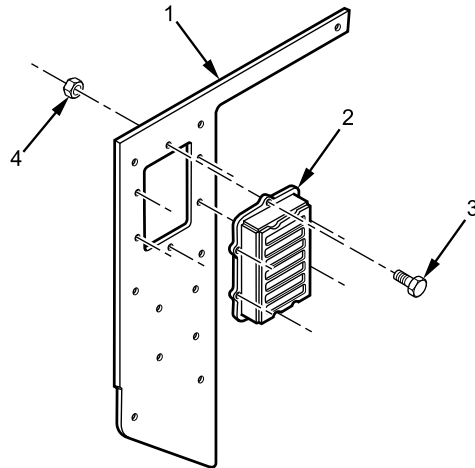

B231801906

Figure 4. Rear Window Riot Guard.

2. Remove four bolts (Figure 5, Item 4), washers (Figure 5, Item 3), and locknuts (Figure 5, Item 5) from fuel/water can mount (Figure 5, Item 2) on armor panel (Figure 5, Item 1). Remove fuel/water can mount (Figure 5, Item 2). Discard locknuts.

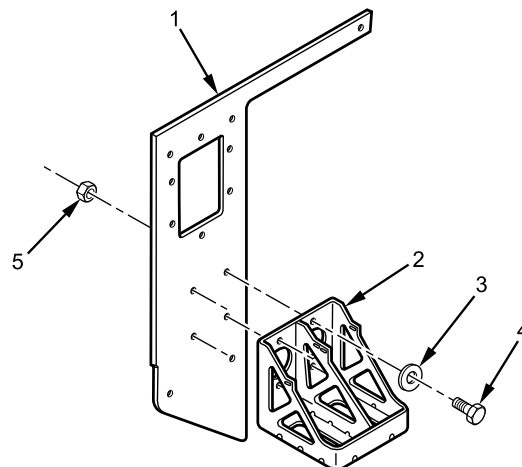

B231801898

Figure 5. Fuel/Water Can Mount.

END OF TASK

BODY ARMOR REAR WALL, RIOT GUARD, AND BRACKET REMOVAL AND INSTALLATION - (CONTINUED)**ASSEMBLY**

1. Install fuel/water can mount (Figure 6, Item 2) on armor panel (Figure 6, Item 1) with four bolts (Figure 6, Item 4), washers (Figure 6, Item 3), and new locknuts (Figure 6, Item 5). Tighten bolts (Figure 6, Item 4) securely.

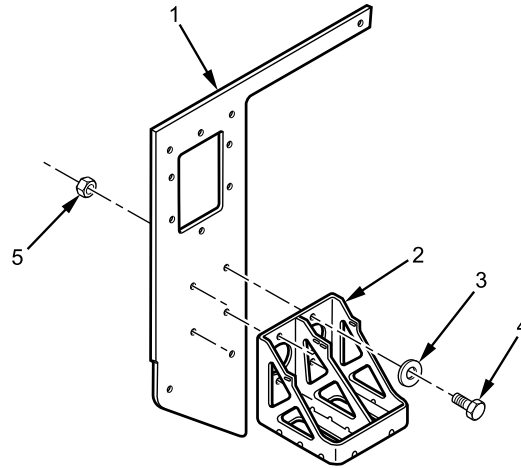

Figure 6. Fuel/Water Mount.

2. Install rear window riot guard (Figure 7, Item 2) on armor panel (Figure 7, Item 1) with six bolts (Figure 7, Item 3) and new locknuts (Figure 7, Item 4). Tighten bolts (Figure 7, Item 3) securely.

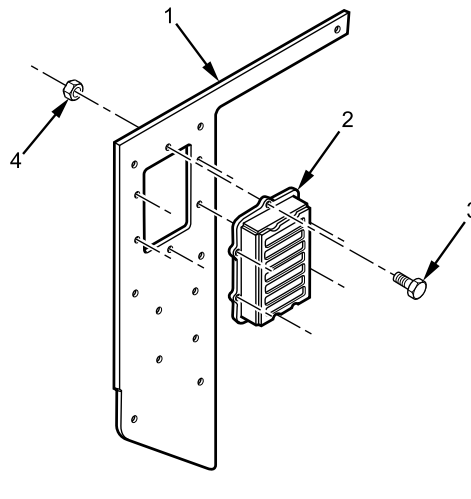

Figure 7. Rear Window Riot Guard.

END OF TASK

BODY ARMOR REAR WALL, RIOT GUARD, AND BRACKET REMOVAL AND INSTALLATION - (CONTINUED)**INSTALLATION****WARNING**

Corrosion preventive compound is toxic. Use only in well-ventilated area. Do not get in eyes; wear chemical safety goggles and full-face shield when using. Avoid contact with skin and wear rubber or plastic, solvent-resistant gloves. In case of contact, remove contaminated clothing and immediately wash area with soap and water. If compound contacts eyes, flush eyes with large amounts of water for at least 15 minutes and get immediate medical attention. If swallowed, do not induce vomiting; contact a physician immediately. Failure to comply may result in serious injury or death to personnel.

1. Apply corrosion preventive compound on four rear wall body armor mounting bolts (Figure 8, Item 2).

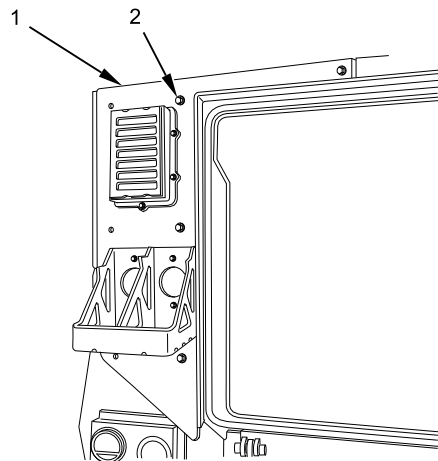

B231801908

Figure 8. Rear Wall Body Armor.

BODY ARMOR REAR WALL, RIOT GUARD, AND BRACKET REMOVAL AND INSTALLATION - (CONTINUED)

2. With assistant, install rear wall body armor (Figure 8, Item 1) with four bolts and washers (Figure 8, Item 2). Tighten bolts (Figure 8, Item 2) securely.
3. Apply corrosion preventive compound on light bar mounting bolt (Figure 9, Item 2).

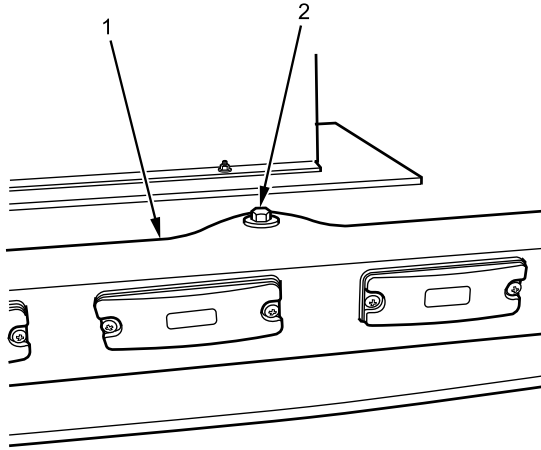

B231801896

Figure 9. Upper Light Bar, Above Rear Door.

4. Install light bar (Figure 9, Item 1) with bolt (Figure 9, Item 2). Tighten bolt (Figure 9, Item 2) securely.

BODY ARMOR REAR WALL, RIOT GUARD, AND BRACKET REMOVAL AND INSTALLATION - (CONTINUED)

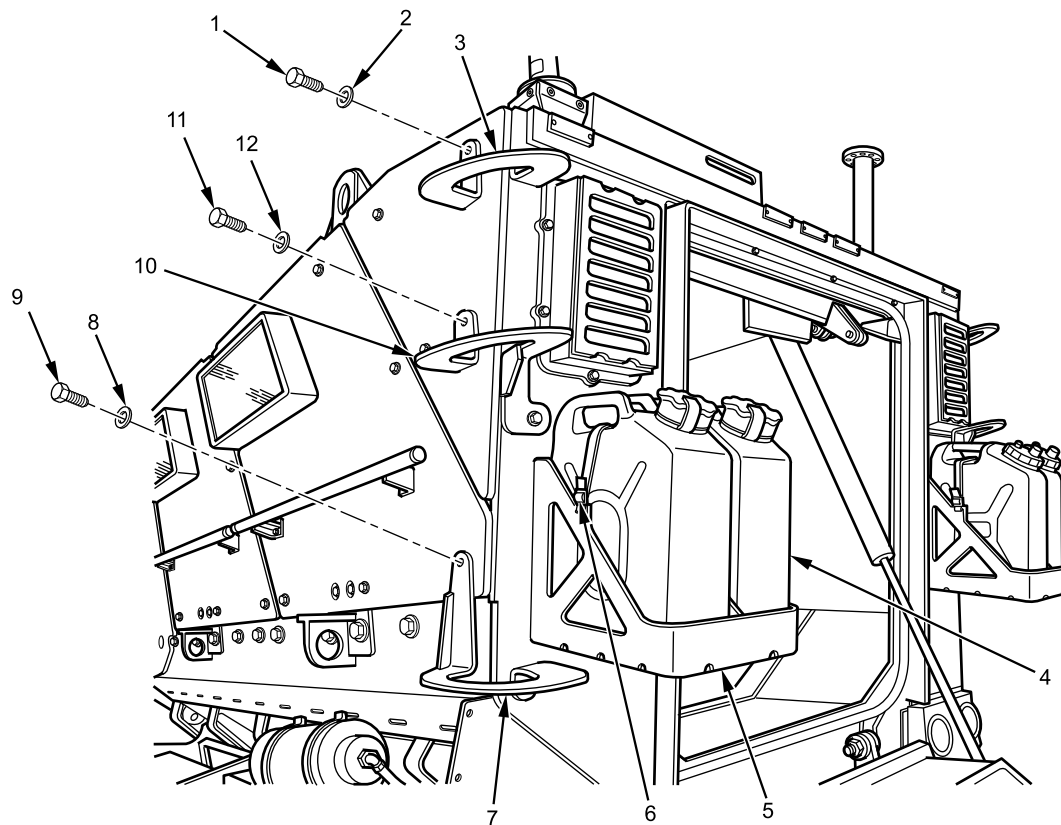

B231801897

Figure 10. Rear Ladder.

5. Apply corrosion preventive compound on two lower ladder step mounting bolts (Figure 10, Item 9).
6. Install lower ladder step (Figure 10, Item 7) with two bolts (Figure 10, Item 9) and washers (Figure 10, Item 8). Tighten bolts (Figure 10, Item 9) securely.
7. Apply corrosion preventive compound on two middle ladder step mounting bolts (Figure 10, Item 11).
8. Install middle ladder step (Figure 10, Item 10) with two bolts (Figure 10, Item 11) and washers (Figure 10, Item 12). Tighten bolts (Figure 10, Item 11) securely .
9. Apply corrosion preventive compound on two upper ladder step mounting bolts (Figure 10, Item 1).
10. Install upper ladder step (Figure 10, Item 3) with two bolts (Figure 10, Item 1) and washers (Figure 10, Item 2). Tighten bolts (Figure 10, Item 1) securely.
11. Install fuel/water cans (Figure 10, Item 4) on mount (Figure 10, Item 5).
12. Secure fuel/water cans (Figure 10, Item 4) with holddown strap (Figure 10, Item 6).

END OF TASK**FOLLOW-ON MAINTENANCE**

1. MAIN POWER switch on (TM 9-2355-106-10).
2. Rear door closed (TM 9-2355-106-10).
3. MAIN POWER switch off (TM 9-2355-106-10).
4. Remove wheel chocks (TM 9-2355-106-10).

END OF TASK**END OF WORK PACKAGE**

FIELD MAINTENANCE

REAR WALL OVERLAP REMOVAL AND INSTALLATION

INITIAL SETUP:

Tools and Special Tools

General Mechanic's Tool Kit (GMTK)
(WP 0795, Item 37)

TM 9-2355-106-23P

WP 0786

WP 0782

Materials/Parts

Sealing compound (WP 0794, Item 43)
Gloves (WP 0794, Item 18)
Goggles, industrial (WP 0794, Item 20)
Faceshield, industrial (WP 0794, Item 16)

Equipment Condition

Parking brake set (TM 9-2355-106-10)
Transmission set in NEUTRAL (N) (TM
9-2355-106-10)
Engine off (TM 9-2355-106-10)
MAIN POWER switch off (TM 9-2355-106-10)
Wheels chocked (TM 9-2355-106-10)

References

TM 9-2355-106-10

REMOVAL

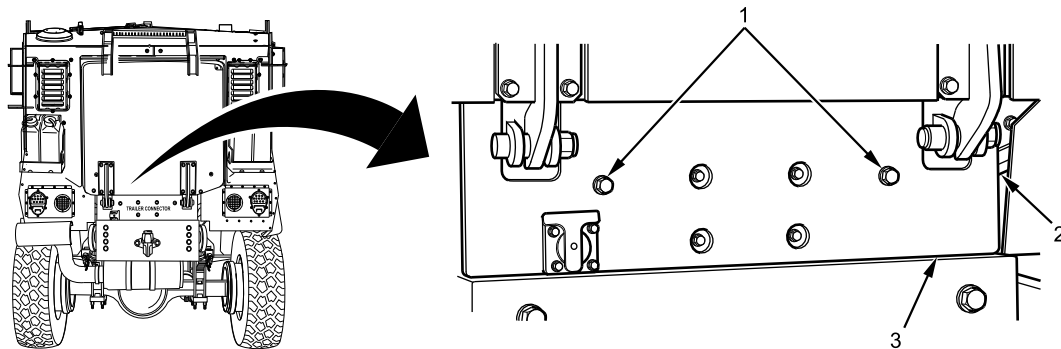

B231810620

Figure 1. Rear Sheet Metal Panel.

1. Remove two bolts (Figure 1, Item 1) from rear sheet metal panel (Figure 1, Item 2) at rear of hull (Figure 1, Item 3).

REAR WALL OVERLAP REMOVAL AND INSTALLATION - (CONTINUED)

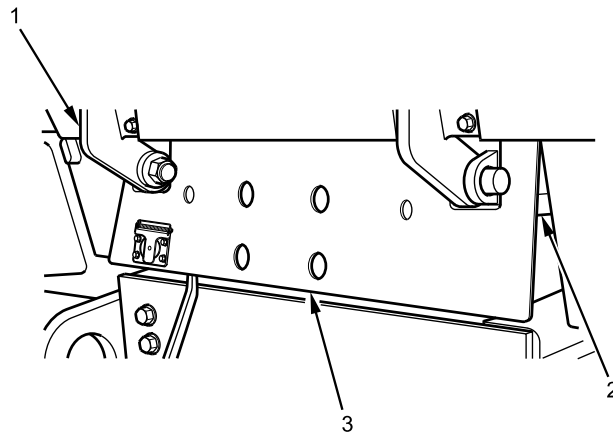

B231803351

Figure 2. Rear Sheet Metal Panel.

2. Pull rear sheet metal panel (Figure 2, Item 3) away from hull (Figure 2, Item 2). Rear sheet metal panel will deform slightly around hinges (Figure 2, Item 1).

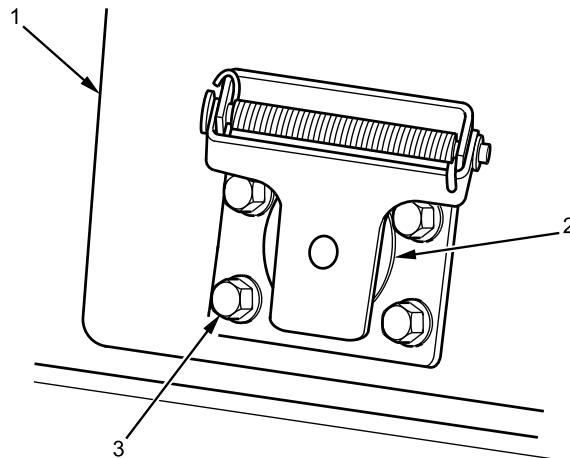

B231803352

Figure 3. Trailer Electrical Socket.

3. Remove four rear trailer electrical socket mounting bolts (Figure 3, Item 3) and nuts, and remove socket (Figure 3, Item 2) and rear sheet metal panel (Figure 3, Item 1).

REAR WALL OVERLAP REMOVAL AND INSTALLATION - (CONTINUED)

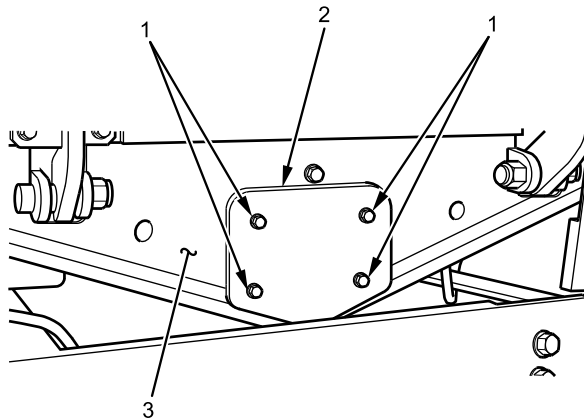

B231803353

Figure 4. Rear Wall Overlap.

4. Remove four bolts (Figure 4, Item 1) from rear wall overlap (Figure 4, Item 2).
5. Remove rear wall overlap (Figure 4, Item 2) from vehicle hull (Figure 4, Item 3).

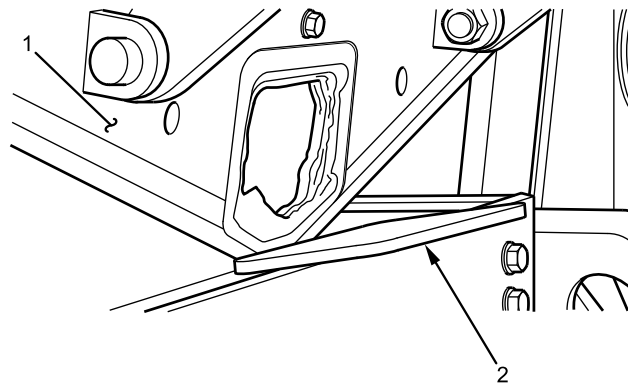

B100000168

Figure 5. Rear Wall Overlap Removed.

6. Pry rear wall overlap (Figure 5, Item 2) from hull (Figure 5, Item 1).

NOTE

Ensure vehicle is on proper incline to drain completely.

7. If water is present:
 - a. Allow water to drain from hull (Figure 5, Item 1).
 - b. Wash hull (Figure 5, Item 1) with fresh water to remove any dirt, debris or salt water.

END OF TASK

REAR WALL OVERLAP REMOVAL AND INSTALLATION - (CONTINUED)

INSTALLATION

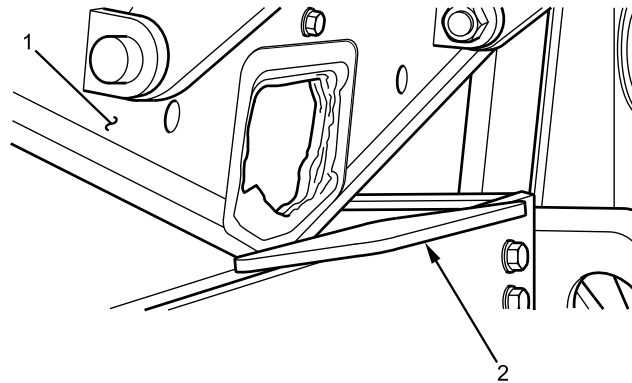

B100000168

Figure 6. Rear Wall Overlap Removed.

1. Scrape old sealing compound from rear wall overlap (Figure 6, Item 2) and vehicle hull (Figure 6, Item 1).

WARNING



Sealing compound is toxic. Use only in well-ventilated area. Do not get in eyes; wear chemical safety goggles and full-face shield when using. Avoid contact with skin and wear rubber or plastic, solvent-resistant gloves. In case of contact, remove contaminated clothing and immediately wash area with soap and water. If compound contacts eyes, flush eyes with large amounts of water for at least 15 minutes and get immediate medical attention. If swallowed, do not induce vomiting; contact a physician immediately. Failure to comply may result in serious injury or death to personnel.

2. Apply bead of sealing compound around inside edge of rear wall overlap (Figure 6, Item 2).

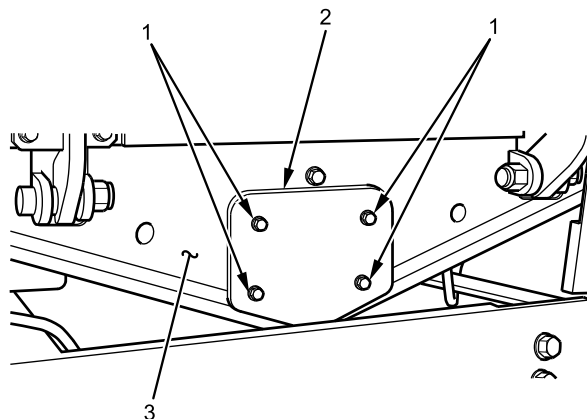

B231803353

Figure 7. Rear Wall Overlap.

REAR WALL OVERLAP REMOVAL AND INSTALLATION - (CONTINUED)

3. Install rear wall overlap (Figure 7, Item 2) on vehicle hull (Figure 7, Item 3) with four bolts (Figure 7, Item 1). Tighten bolts securely.

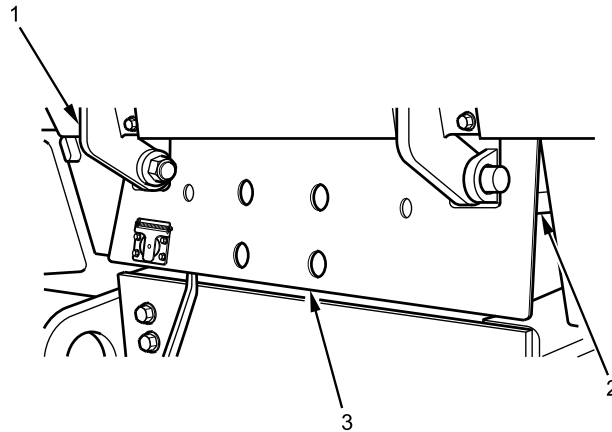

B231803351

Figure 8. Rear Sheet Metal Panel.

4. Position rear sheet metal panel (Figure 8, Item 3) on vehicle hull (Figure 8, Item 2) forward of rear door/ramp hinges (Figure 8, Item 1).

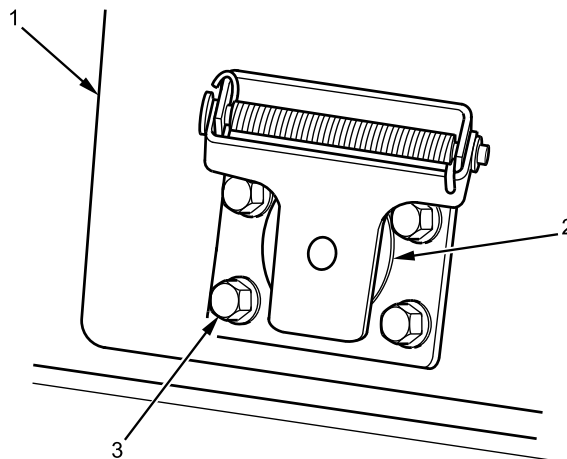

B231803352

Figure 9. Trailer Electrical Socket.

5. Install trailer electrical socket (Figure 9, Item 2) on sheet metal panel (Figure 9, Item 1) with four bolts (Figure 9, Item 3) and nuts.

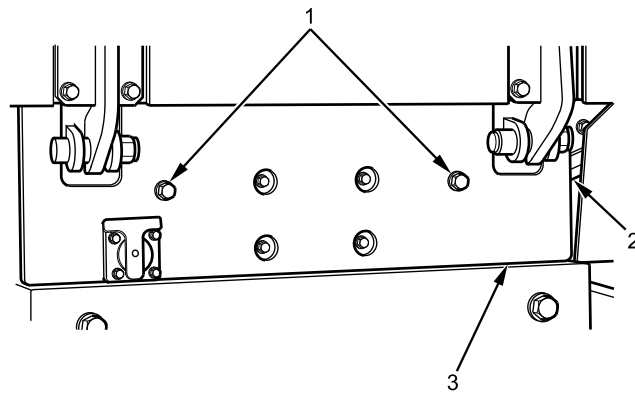
REAR WALL OVERLAP REMOVAL AND INSTALLATION - (CONTINUED)

B231803350

Figure 10. Rear Sheet Metal Panel.

6. Install sheet metal panel (Figure 10, Item 3) to vehicle hull (Figure 10, Item 2) with two bolts (Figure 10, Item 1). Tighten bolts securely.

END OF TASK**FOLLOW-ON MAINTENANCE**

Remove wheel chocks (TM 9-2355-106-10).

END OF TASK**END OF WORK PACKAGE**

FIELD MAINTENANCE**REAR DOOR/RAMP REMOVAL AND INSTALLATION**

INITIAL SETUP:**Tools and Special Tools**

General Mechanic's Tool Kit (GMTK)
(WP 0795, Item 37)
Sling, nylon (WP 0795, Item 91)
Lifting device (WP 0795, Item 67)
Jackstand, 10-ton, 30-52-inches (2) (WP 0795, Item 63)

Materials/Parts

Compound (WP 0794, Item 13)
Goggles, industrial (WP 0794, Item 20)
Faceshield, industrial (WP 0794, Item 16)
Gloves (WP 0794, Item 19)

Personnel Required

Maintainer (2)

References

TM 9-2355-106-10
TM 9-2355-106-23P
WP 0782

Equipment Condition

Parking brake set (TM 9-2355-106-10)
Transmission set in NEUTRAL (N) (TM 9-2355-106-10)
Engine off (TM 9-2355-106-10)
MAIN POWER switch off (TM 9-2355-106-10)
Wheels chocked (TM 9-2355-106-10)
Rear door gas spring removed (WP 0698)

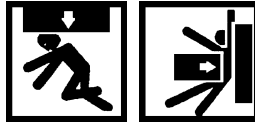
REAR DOOR/RAMP REMOVAL AND INSTALLATION - (CONTINUED)**WARNING**

Armor parts are heavy. Use care when removing or installing. Do not attempt to lift without an assistant and lifting device. Wear gloves. Failure to comply may result in serious injury or death to personnel.

Rear cabin door/ramp is heavy. Make sure door/ramp is secured so it will not move. Failure to comply may result in serious personal injury or death to personnel.

Rear door/ramp is heavy. Ensure lifting device and sling are in place prior to removing rear door/ramp mounting bolts. Failure to comply may result in serious injury or death to personnel.

Ensure no one is behind vehicle when lowering rear door/ramp. Use extreme caution when using emergency rear door/ramp release, to ensure no one is struck by door as it falls open. Sound horn before lowering door/ramp. Keep arms and legs clear of rear door/ramp when closing. Do not operate rear door/ramp when vehicle is in motion. Failure to comply may result in serious injury or death to personnel.

Attach a lifting device and sling to rear door/ramp prior to removing mounting bolts. Failure to comply may result in damage to equipment and serious injury or death to personnel.

Check for hydraulic leak location visually from at least an arm's length away and not within the path of the leak. If leak is suspected in a blind area, use scrap pieces of material such as cardboard or wood to check for location. Never use hand or other body parts. Failure to comply may result in serious injury, amputation, or death to personnel.

Never touch any part of a hydraulic assembly before it is known that the system is depressurized. The rear door actuating system operates under high pressure. Pressurized hydraulic fluid can penetrate skin and body tissue. Contact with pressurized hydraulic fluid requires prompt medical attention, even if an injury is not evident. Failure to comply may result in serious injury, amputation, or death to personnel.

REAR DOOR/RAMP REMOVAL AND INSTALLATION - (CONTINUED)

REMOVAL

1. Lower rear door/ramp assembly (Figure 1, Item 1) onto two tall 10-ton jackstands (Figure 1, Item 2) from closed ramp position.

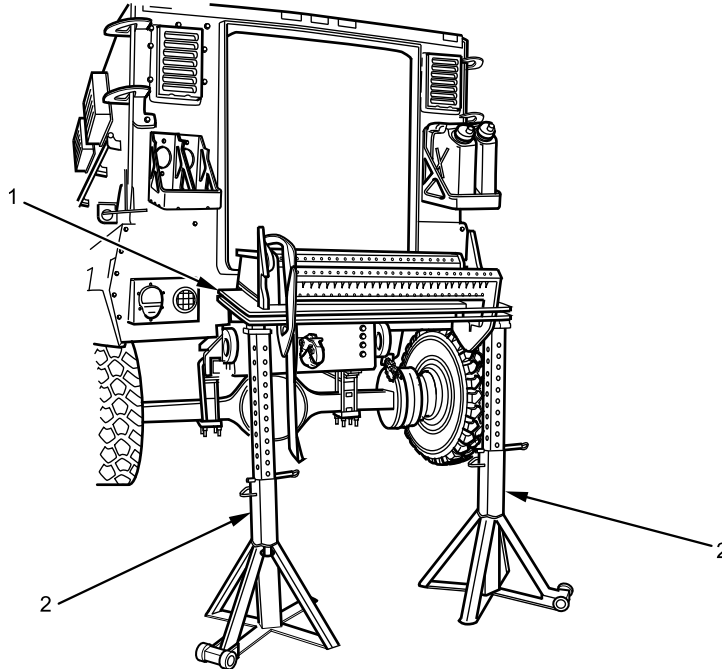

B231803114

Figure 1. Rear Door/Ramp Assembly Lowered.

2. Loop lifting sling (Figure 2, Item 4) around rear door/ramp left hinge (Figure 2, Item 1) between ramp door (Figure 2, Item 2) and ramp door armor panel (Figure 2, Item 3).

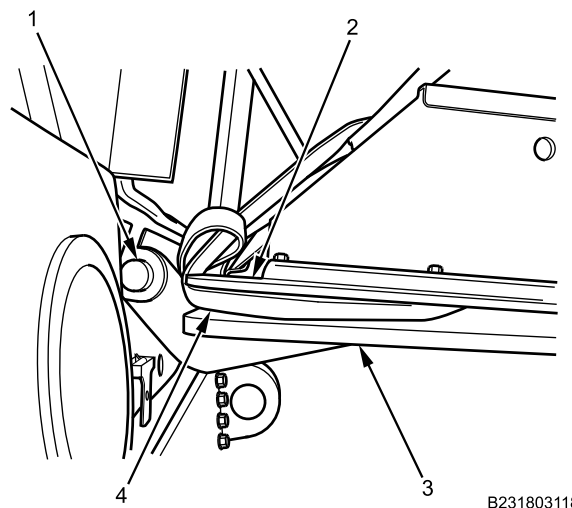

B231803118

Figure 2. Loop Lifting Sling Around Door/Ramp Left Hinge.

REAR DOOR/RAMP REMOVAL AND INSTALLATION - (CONTINUED)

3. Loop lifting sling (Figure 3, Item 2) around rear door/ramp right hinge (Figure 3, Item 1) between ramp door (Figure 3, Item 4) and ramp door armor panel (Figure 3, Item 3).

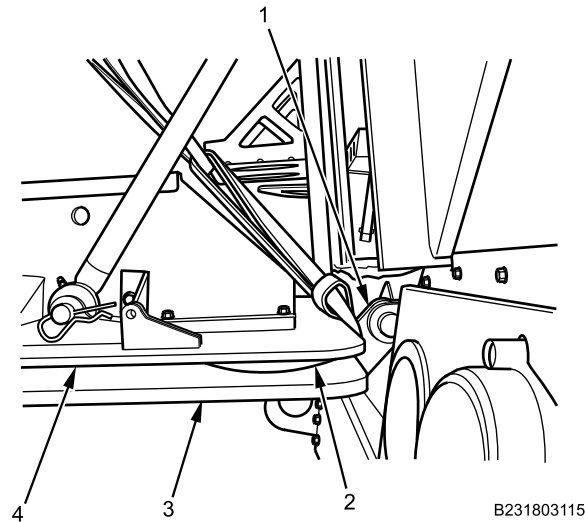

Figure 3. Loop Lifting Sling Around Door/Ramp Right Hinge.

4. Loop lifting sling (Figure 4, Item 1) around rear door/ramp armor mounting boss between rear door/ramp (Figure 4, Item 3) and ramp door armor (Figure 4, Item 2) on left side of ramp.

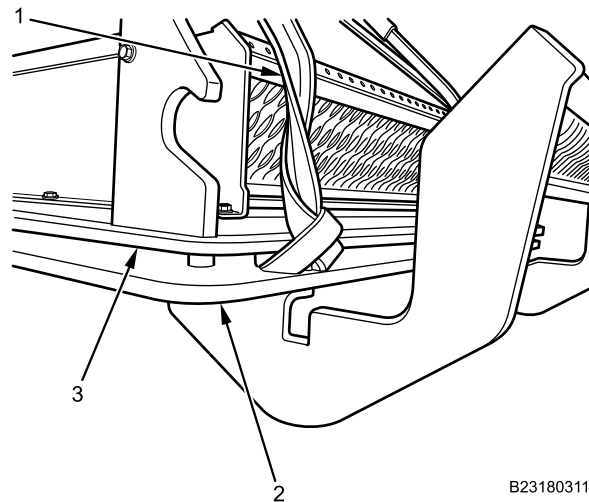

Figure 4. Loop Lifting Sling Around Door/Ramp Left Rear Mounting Boss.

5. Loop lifting sling (Figure 5, Item 1) around rear door/ramp armor mounting boss between rear door/ramp (Figure 5, Item 2) and ramp door armor (Figure 5, Item 3) on right side of ramp.

REAR DOOR/RAMP REMOVAL AND INSTALLATION - (CONTINUED)

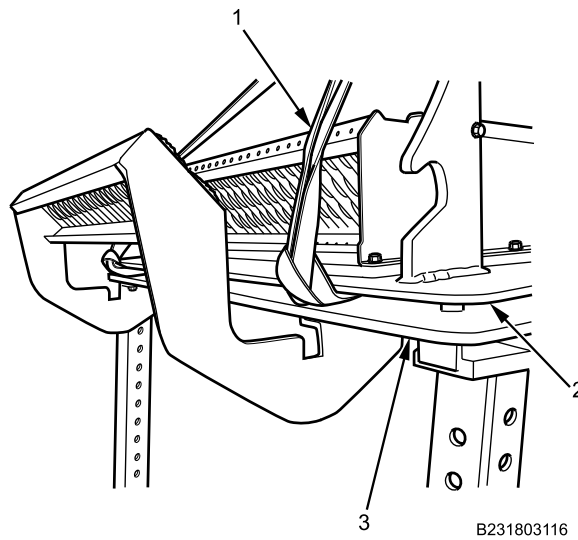

Figure 5. Loop Lifting Sling Around Door/Ramp Right Rear Mounting Boss.

6. Route a fifth lifting sling (Figure 6, Item 1) through the ends of the two lifting slings on ramp/door hinge end (Figure 6, Item 4) up to a shackle (Figure 6, Item 2).

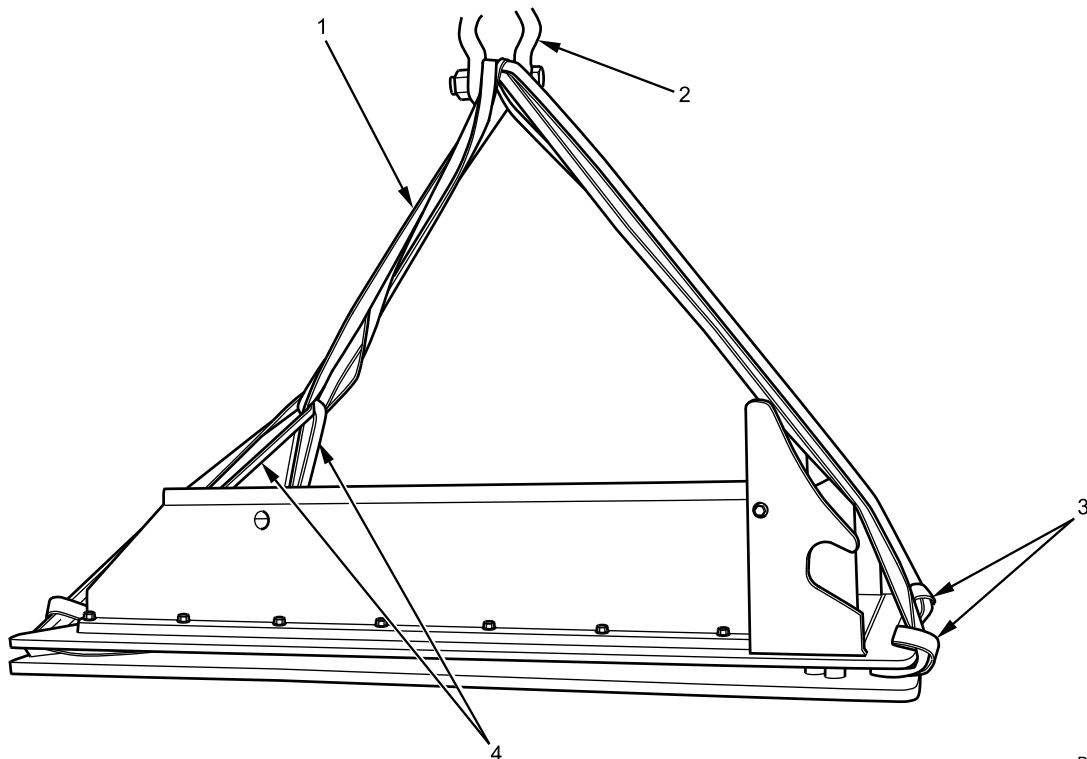
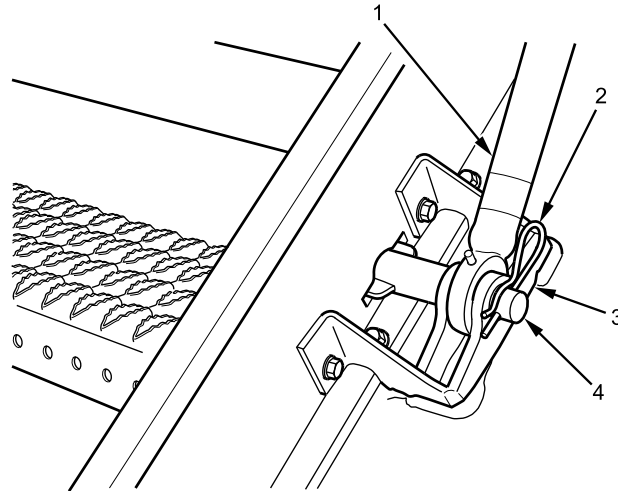

Figure 6. Route Ends of Slings Through a Fifth Sling.

7. Attach the ends of the two lifting slings (Figure 6, Item 3) from the lower step end of ramp/door to shackle (Figure 6, Item 2).

REAR DOOR/RAMP REMOVAL AND INSTALLATION - (CONTINUED)

8. Tension sling to safely lift ramp assembly.
9. Remove locking safety pin (Figure 7, Item 2) and door/ramp pin (Figure 7, Item 4) connecting hydraulic cylinder (Figure 7, Item 1) to lower ramp bracket (Figure 7, Item 3).



B231802849

Figure 7. Locking Safety Pin Removed from Hydraulic Cylinder.

10. Turn MAIN POWER switch on. Raise hydraulic cylinder for clearance. Turn MAIN POWER switch off.
11. Remove two nuts and bolts (Figure 8, Item 1) from two mounting brackets (Figure 8, Item 2) welded on vehicle frame.

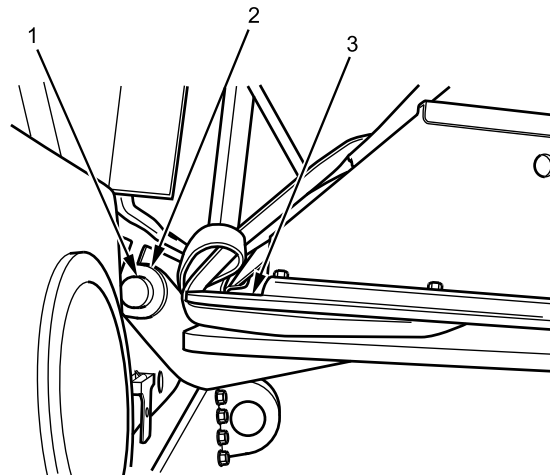

B231803155

Figure 8. Rear Door/Ramp Removed from Vehicle.

12. With assistance and a suitable lifting device, remove rear door/ramp assembly (Figure 8, Item 3).

END OF TASK

REAR DOOR/RAMP REMOVAL AND INSTALLATION - (CONTINUED)**INSTALLATION**

1. Loop lifting sling (Figure 9, Item 4) around rear door/ramp left hinge (Figure 9, Item 1) between ramp door (Figure 9, Item 2) and ramp door armor panel (Figure 9, Item 3).

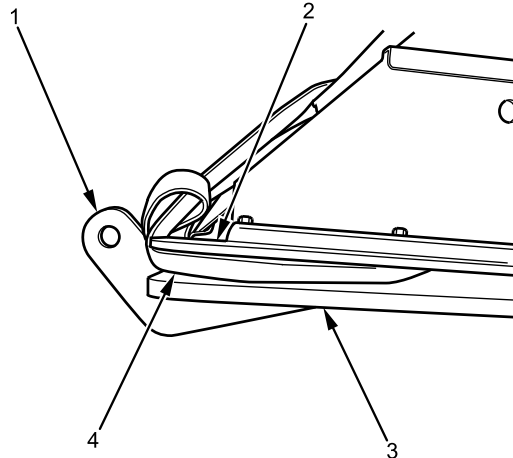

B231804032

Figure 9. Rear Door/Ramp Assembly Installed.

2. Loop lifting sling (Figure 10, Item 2) around rear door/ramp right hinge (Figure 10, Item 1) between ramp door (Figure 10, Item 4) and ramp door armor panel (Figure 10, Item 3).

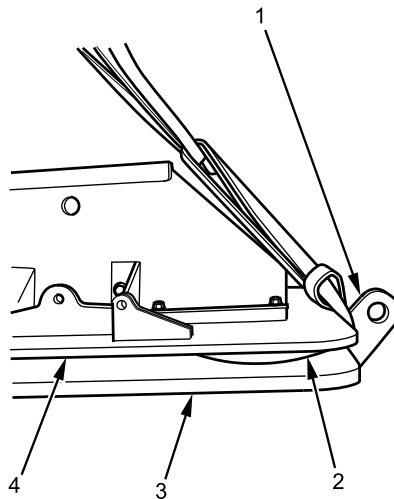

B231804030

Figure 10. Loop Lifting Sling Around Door/Ramp Right Hinge.

REAR DOOR/RAMP REMOVAL AND INSTALLATION - (CONTINUED)

3. Loop lifting sling (Figure 11, Item 1) around rear door/ramp armor mounting boss between the rear door/ramp (Figure 11, Item 3) and ramp door armor (Figure 11, Item 2) on the left side of ramp at bottom step.

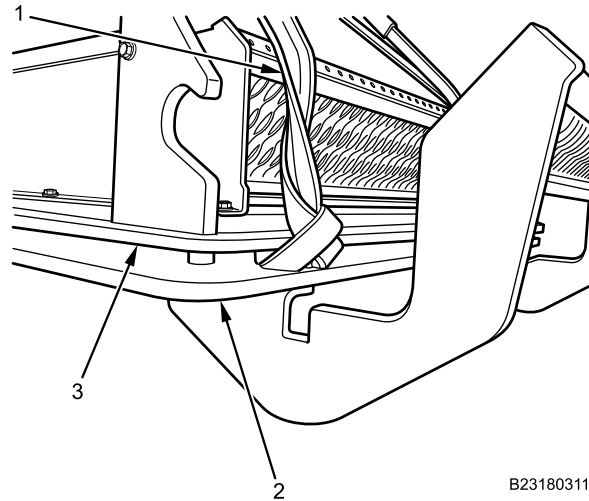

B231803117

Figure 11. Loop Lifting Sling Around Door/Ramp Right Hinge.

4. Loop lifting sling (Figure 12, Item 1) around rear door/ramp armor mounting boss between rear door/ramp (Figure 12, Item 2) and ramp door armor (Figure 12, Item 3) on right side of ramp at bottom step.

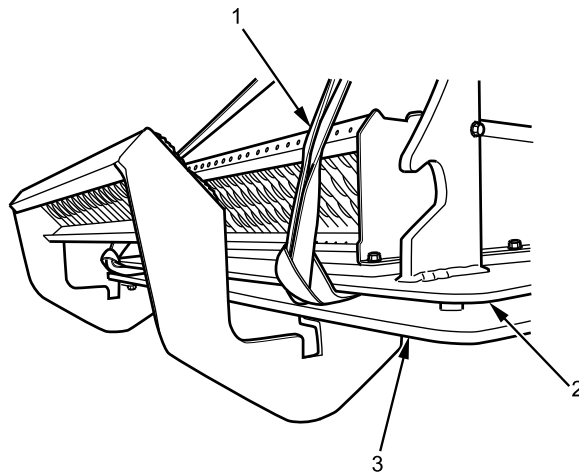

B231804031

Figure 12. Loop Lifting Sling Around Door/Ramp Right Hinge.

REAR DOOR/RAMP REMOVAL AND INSTALLATION - (CONTINUED)

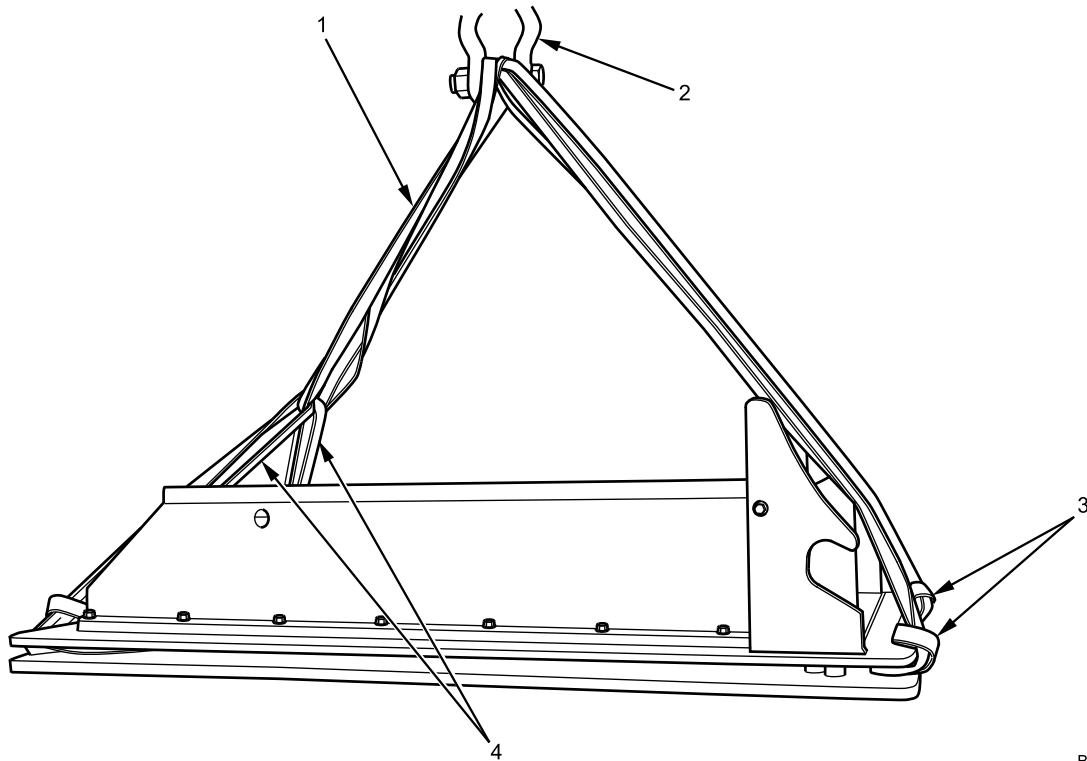

B231803113

Figure 13. Loop Lifting Sling Around Door/Ramp Right Hinge.

5. Route a fifth lifting sling (Figure 13, Item 1) through ends of the two lifting slings on ramp/door hinge end (Figure 13, Item 4) up to a shackle (Figure 13, Item 2).
6. Attach the ends of two lifting slings (Figure 13, Item 3) from lower step end of ramp/door to the shackle (Figure 13, Item 2).
7. Tension sling to safely support ramp assembly.
8. With assistant, attach shackle to lifting device and lift door ramp into position on two mounting brackets welded on vehicle frame.
9. Lower rear door/ramp onto two tall 10-ton jackstands for added support and safety.

REAR DOOR/RAMP REMOVAL AND INSTALLATION - (CONTINUED)

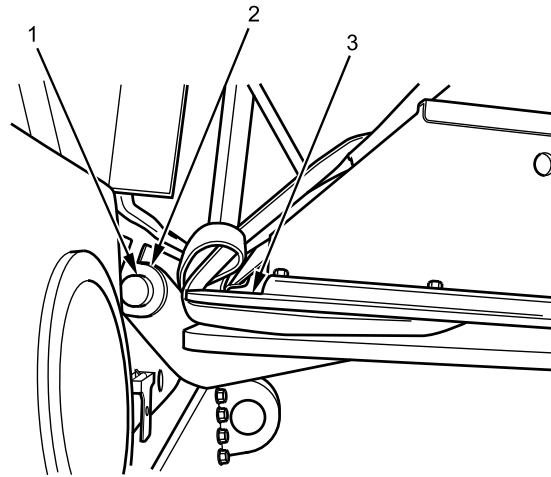

B231803155

Figure 14. Rear Door/Ramp Assembly Installed.

10. Insert two bolts (Figure 14, Item 1) through mounting brackets (Figure 14, Item 2) securing ramp (Figure 14, Item 3) to vehicle.
11. Install two nuts on bolts (Figure 14, Item 1) and tighten securely.

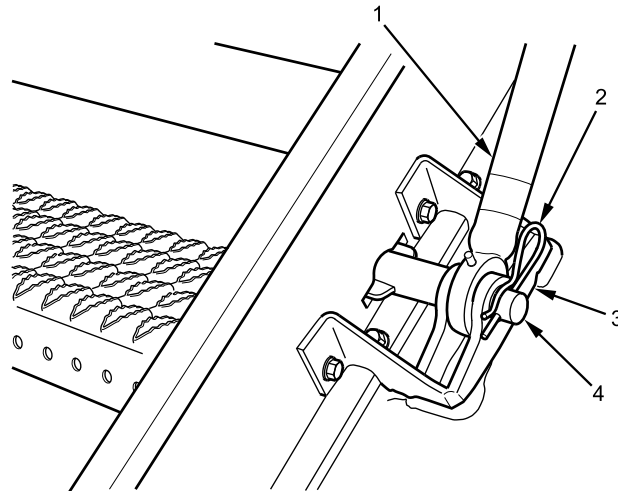

B231802849

Figure 15. Hydraulic Cylinder Secured with Locking Safety Pin.

12. Turn MAIN POWER switch on, lower hydraulic cylinder (Figure 15, Item 1), and align cylinder with lower door/ramp bracket (Figure 15, Item 3).
13. Install door ramp pin (Figure 15, Item 4) and locking safety pin (Figure 15, Item 2).
14. Remove lifting device, slings, and jackstands.
15. Raise door/ramp to verify door/ramp operation.

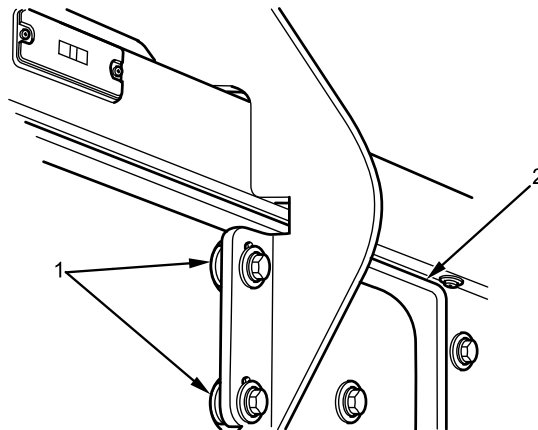
REAR DOOR/RAMP REMOVAL AND INSTALLATION - (CONTINUED)

B231800766

Figure 16. Bottom Step Adjusted with Spacers.

16. If needed, adjust bottom step by adding flat washers (Figure 16, Item 1) at individual bolt locations so bottom step does not strike door frame (Figure 16, Item 2) at top of vehicle, but allows proper sealing of rear/door ramp.
17. Turn MAIN POWER switch off.

END OF TASK**FOLLOW-ON MAINTENANCE**

1. Install rear door gas spring (WP 0698).
2. Remove wheel chocks (TM 9-2355-106-10).

END OF TASK**END OF WORK PACKAGE**

FIELD MAINTENANCE

BOTTOM RAMP STEP REMOVAL AND INSTALLATION

INITIAL SETUP:

Tools and Special Tools

General Mechanic's Tool Kit (GMTK)
(WP 0795, Item 37)

TM 9-2355-106-23P

WP 0786

WP 0782

Materials/Parts

Lockwashers - (2) (WP 0796, Item 160)
Gloves (WP 0794, Item 19)

Equipment Condition

Parking brake set (TM 9-2355-106-10)

Transmission set in NEUTRAL (N) (TM 9-2355-106-10)

Engine off (TM 9-2355-106-10)

MAIN POWER switch off (TM 9-2355-106-10)

Wheels chocked (TM 9-2355-106-10)

Personnel Required

Maintainer - (2)

References

TM 9-2355-106-10

WARNING



Armor parts are heavy. Use care when removing or installing. Do not attempt to lift without an assistant and lifting device. Wear gloves. Failure to comply may result in serious injury or death to personnel.

REMOVAL

1. With assistant, remove four bolts (Figure 1, Item 2), washers, lockwashers, and door ramp step (Figure 1, Item 1) from rear door/ramp (Figure 1, Item 3). Discard lockwashers.

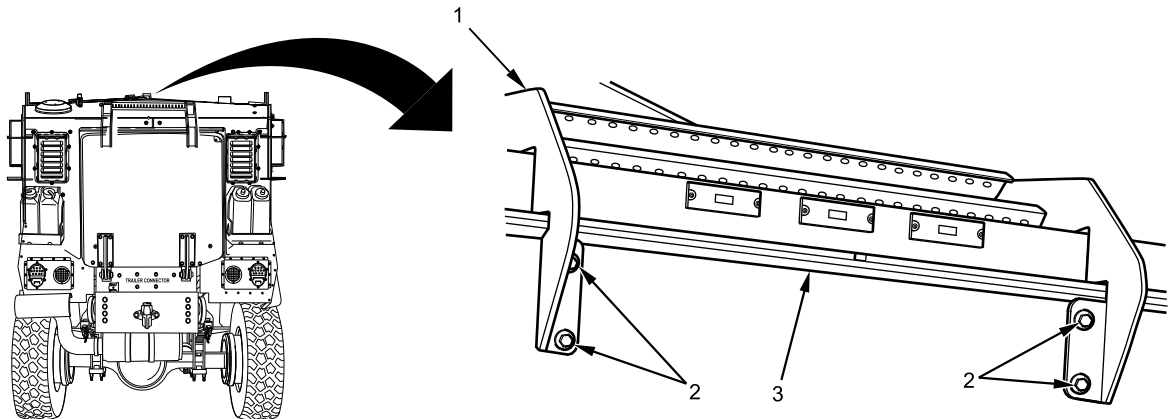

B231810706

Figure 1. Bottom Ramp Step Removal from Ramp.

END OF TASK

BOTTOM RAMP STEP REMOVAL AND INSTALLATION - (CONTINUED)**INSTALLATION**

1. With assistant, install bottom ramp step (Figure 2, Item 1) on rear door/ramp (Figure 2, Item 3) with four washers, four new lockwashers, and four bolts (Figure 2, Item 2).

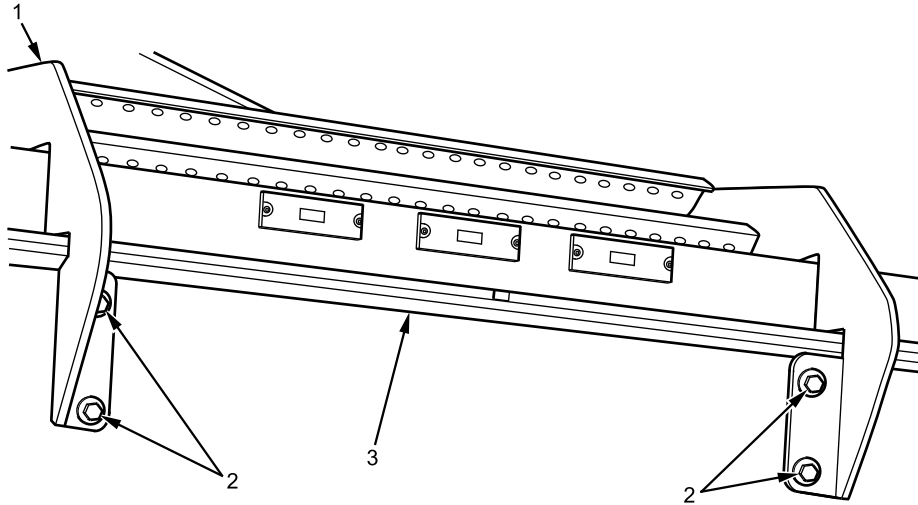

B231800767

Figure 2. Bottom Ramp Step Installation.

2. Adjust rear door ramp step for adequate clearance between step and vehicle. Tighten bolts securely.

END OF TASK**FOLLOW-ON MAINTENANCE**

1. Turn MAIN POWER switch on (TM 9-2355-106-10).
2. Turn ignition switch on (TM 9-2355-106-10).
3. Verify rear door/ramp operation. Adjust step if necessary (TM 9-2355-106-10).
4. Turn ignition switch off (TM 9-2355-106-10).
5. Turn MAIN POWER switch off (TM 9-2355-106-10).
6. Remove wheel chocks (TM 9-2355-106-10).

END OF TASK**END OF WORK PACKAGE**

FIELD MAINTENANCE**REAR DOOR/RAMP LOCK ASSEMBLY REMOVAL AND INSTALLATION**

INITIAL SETUP:**Tools and Special Tools**

General Mechanic's Tool Kit (GMTK)
(WP 0795, Item 37)
Puller set, mechanical (WP 0795, Item 78)

TM 9-2355-106-23P

WP 0786

WP 0782

Materials/Parts

Lockwasher - (8) (WP 0796, Item 24)

Equipment Condition

Parking brake set (TM 9-2355-106-10)

Transmission set in NEUTRAL (N) (TM
9-2355-106-10)

Engine off (TM 9-2355-106-10)

MAIN POWER switch off (TM 9-2355-106-10)

Wheels chocked (TM 9-2355-106-10)

Personnel Required

Maintainer (2)

References

TM 9-2355-106-10

NOTE

Personnel should review this procedure prior to performing removal and installation.

REMOVAL

1. Lower rear door/ramp assembly (Figure 1, Item 1).

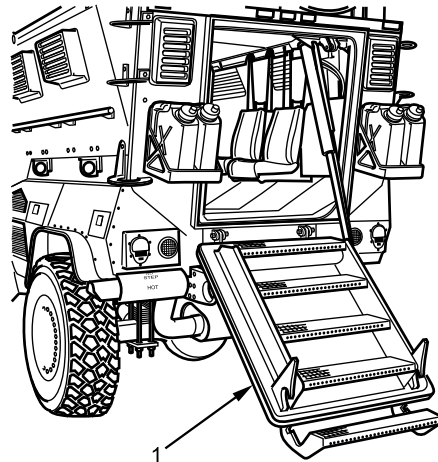

B231801603

Figure 1. Rear Door/Ramp Assembly Lowered.

REAR DOOR/RAMP LOCK ASSEMBLY REMOVAL AND INSTALLATION - (CONTINUED)

2. Remove four bolts (Figure 2, Item 2) and right side door lock assembly shroud cover (Figure 2, Item 3) from roof-mounted bracket (Figure 2, Item 1).

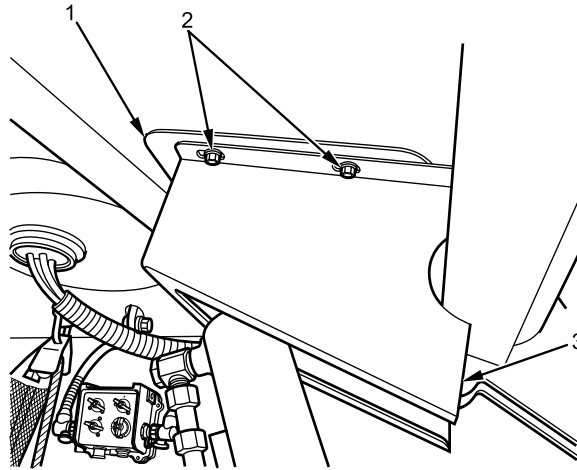

B231801697

Figure 2. Right Side Shroud Cover Removal.

3. Remove three bolts (Figure 3, Item 1) and left side door lock assembly shroud cover (Figure 3, Item 2) from roof-mounted bracket (Figure 3, Item 3).

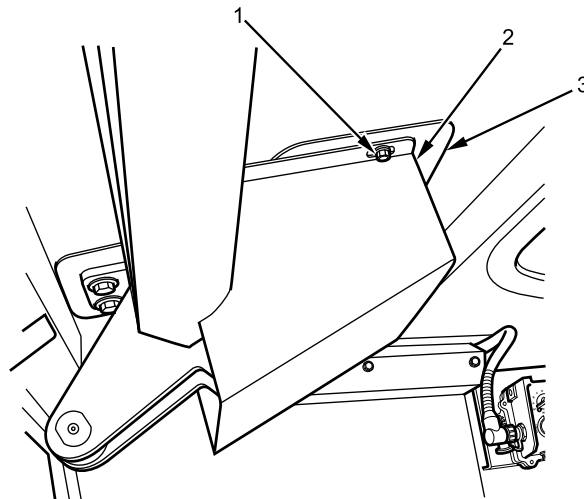

B231801698

Figure 3. Left Side Shroud Cover Removal.

4. Remove two coil springs (Figure 4, Item 1) from grooves (Figure 4, Item 2) of right side rear door lock shaft. Remove springs from vehicle. Right side shown, left side similar.

REAR DOOR/RAMP LOCK ASSEMBLY REMOVAL AND INSTALLATION - (CONTINUED)

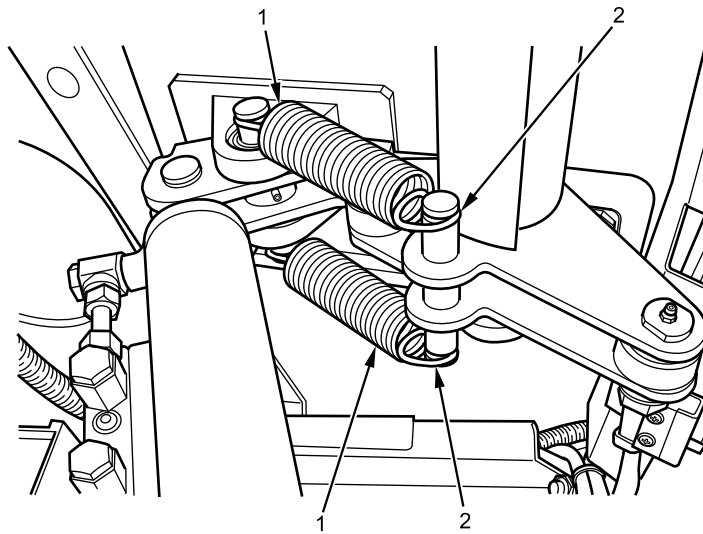

B231802051

Figure 4. Coil Springs Removal from Door Lock Assembly.

NOTE

Door lock assembly has four bolts on each roof bracket. Do not remove remaining bolt until ready for removal.

5. Remove three bolts, washers, and lockwashers, holding left side door lock assembly bracket (Figure 5, Item 1) to roof bracket (hidden). Discard lockwashers.

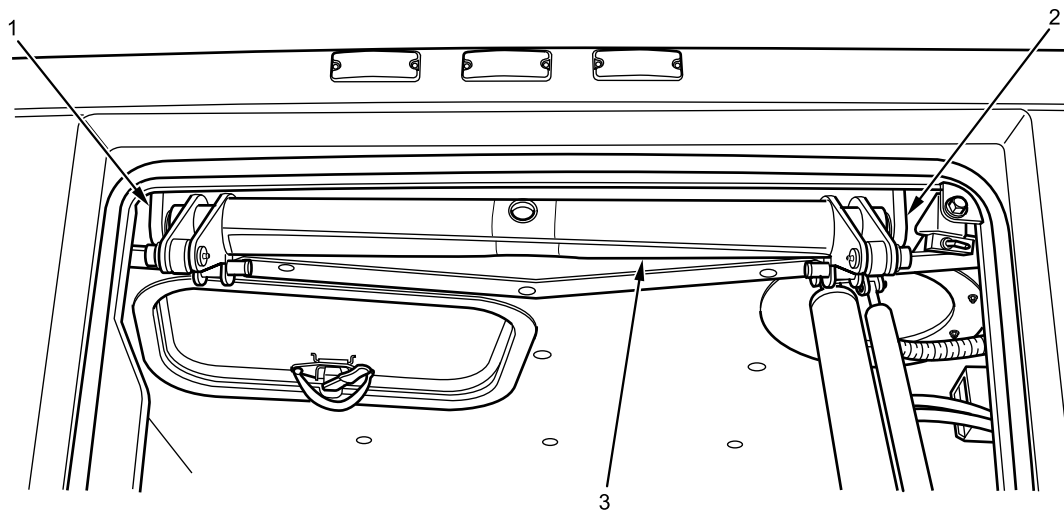

B231802069

Figure 5. Rear Door Lock Assembly Mounting Brackets Removal.

6. Remove three bolts, washers, and lockwashers, holding right side door lock assembly bracket (Figure 5, Item 2) to roof bracket (hidden). Discard lockwashers.
7. With assistant, remove remaining bolt, washer, and lockwasher, from door lock assembly brackets (Figure 5, Item 1 and 2) and remove door lock assembly (Figure 5, Item 3) from vehicle. Discard lockwasher.

REAR DOOR/RAMP LOCK ASSEMBLY REMOVAL AND INSTALLATION - (CONTINUED)

8. Remove four bracket mounting screws (Figure 6, Item 2) from right and left ends of rear door lock assembly (Figure 6, Item 1).

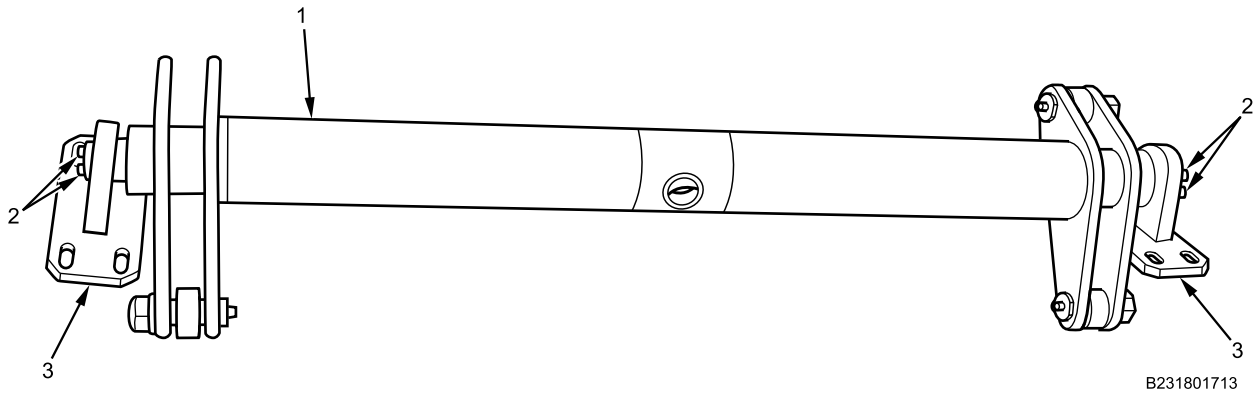

Figure 6. Rear Door Lock Assembly Removed from Vehicle.

9. Separate two attached roof-mounted brackets (Figure 7, Item 1) from rear door lock assembly (Figure 7, Item 3), using 2-jaw puller (Figure 7, Item 2).

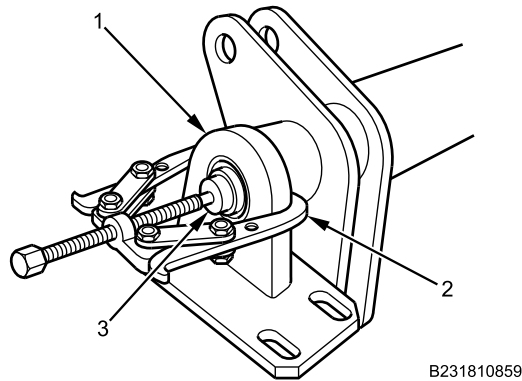

Figure 7. Rear Door Lock Assembly with Mounting Brackets Removed.

END OF TASK

REAR DOOR/RAMP LOCK ASSEMBLY REMOVAL AND INSTALLATION - (CONTINUED)**INSTALLATION**

1. Install two roof-mounted brackets (Figure 8, Item 3) on ends of rear door lock assembly (Figure 8, Item 1) with four screws (Figure 8, Item 2). Tighten screws securely.

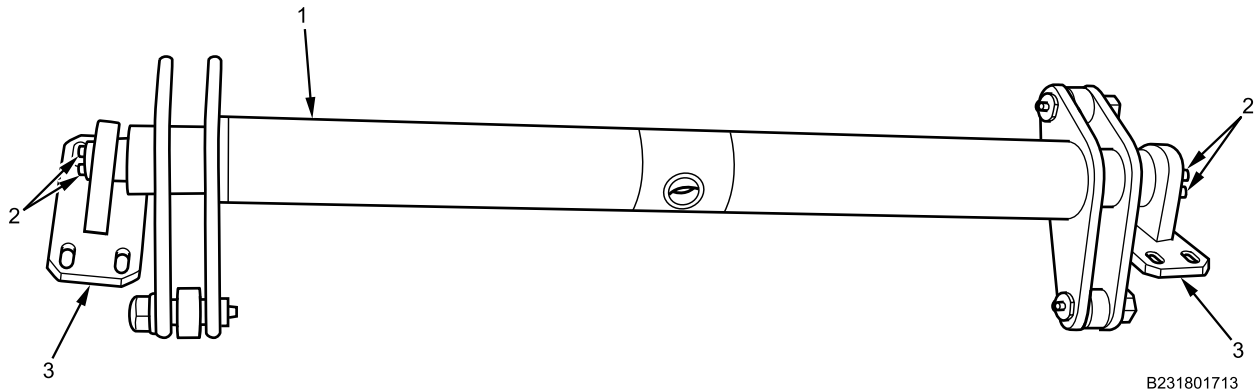

Figure 8. Mounting Brackets Installed on Rear Door Lock Assembly.

CAUTION

When installing rear door lock assembly on vehicle, make sure assistant supports full weight of rear door lock assembly until two mounting bolts have been installed, but not tightened, on each roof-mounted door lock assembly bracket. Failure to comply may result in damage to equipment.

2. With assistant, install door lock assembly (Figure 9, Item 3) and brackets (Figure 9, Item 1 and 2) to roof brackets (hidden) with eight bolts, washers, and new lockwashers. Tighten bolts securely.

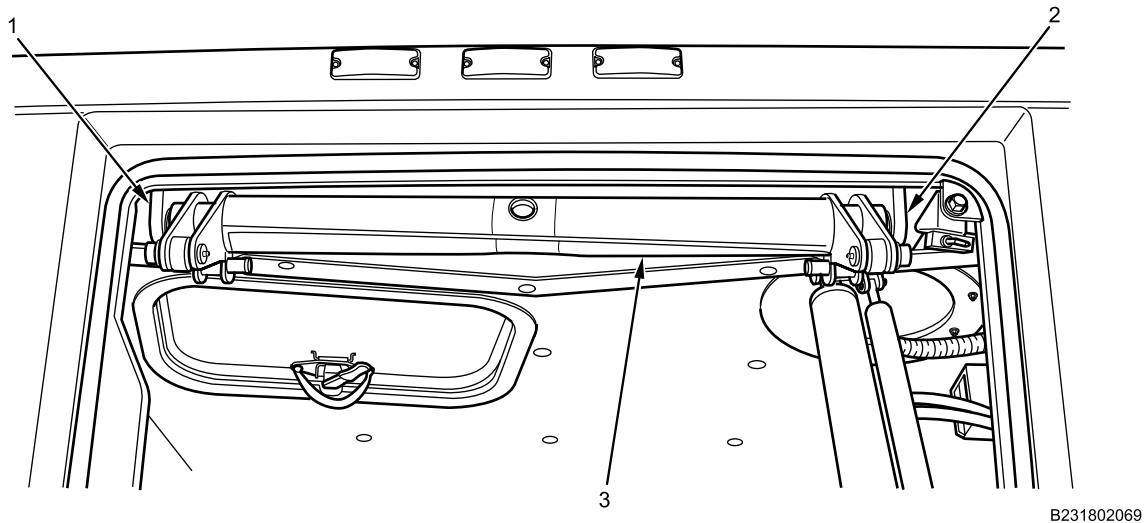
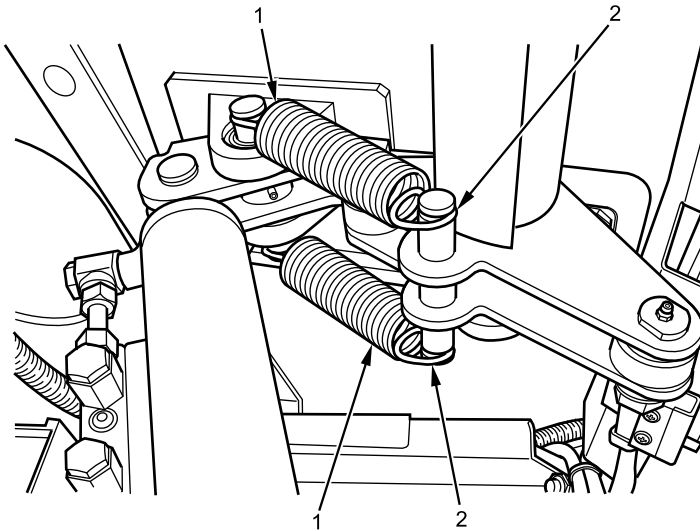

Figure 9. Rear Door Lock Assembly Installed.

REAR DOOR/RAMP LOCK ASSEMBLY REMOVAL AND INSTALLATION - (CONTINUED)

3. Install two coil springs (Figure 10, Item 1) on right side roof-mounted bracket shaft grooves and rear door lock assembly shaft grooves (Figure 10, Item 2). Right side shown, left side similar.



B231802051

Figure 10. Coil Springs Installed on Rear Door Lock Assembly and Roof-Mounted Brackets.

4. Turn MAIN POWER switch on.

NOTE

If ramp assembly does not latch properly, loosen bolts, and adjust door lock assembly for proper operation. Tighten bolts securely.

5. Raise rear door/ramp assembly to closed position and verify door latch operation.
6. Lower rear door/ramp assembly (Figure 11, Item 1).

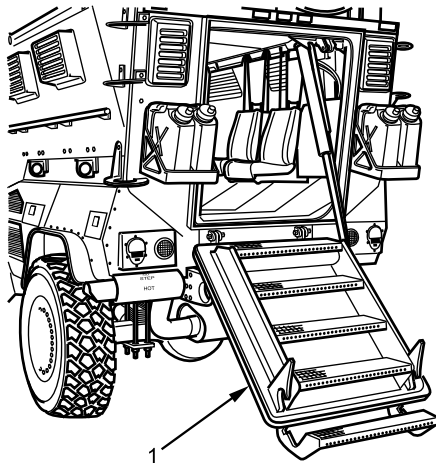

B231801603

Figure 11. Rear Door/Ramp Assembly Lowered.

7. Turn MAIN POWER switch off.

REAR DOOR/RAMP LOCK ASSEMBLY REMOVAL AND INSTALLATION - (CONTINUED)

8. Install right side door lock assembly shroud cover (Figure 12, Item 3) on right side roof-mounted bracket (Figure 12, Item 1) with four bolts (Figure 12, Item 2). Tighten bolts securely.

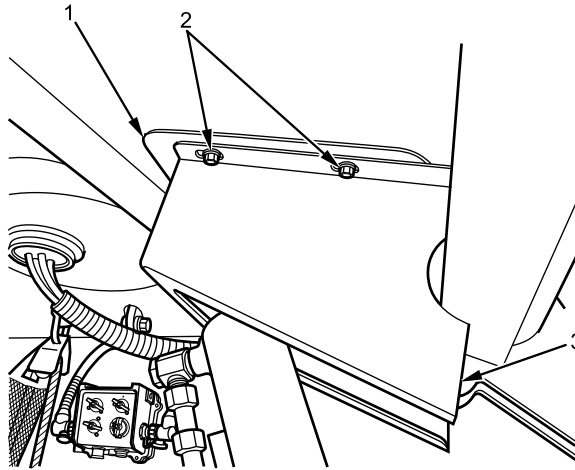

B231801697

Figure 12. Right Side Shroud Cover Installed on Roof-Mounted Bracket.

9. Install left side door lock assembly shroud cover (Figure 13, Item 2) on left side roof-mounted bracket (Figure 13, Item 3) with three bolts (Figure 13, Item 1). Tighten bolts securely.

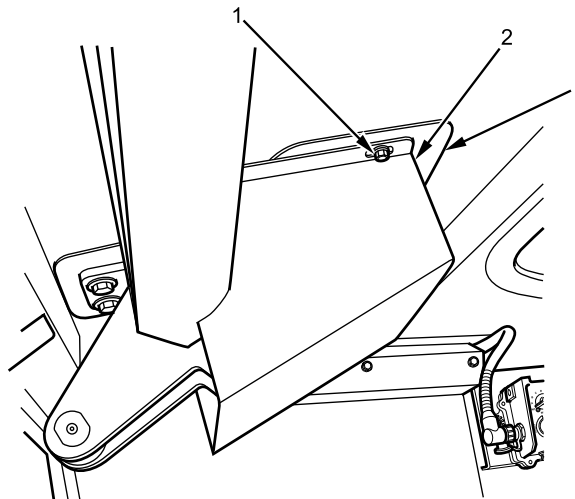

B231801698

Figure 13. Left Side Shroud Cover Installed on Roof-Mounted Bracket.

END OF TASK

REAR DOOR/RAMP LOCK ASSEMBLY REMOVAL AND INSTALLATION - (CONTINUED)**FOLLOW-ON MAINTENANCE**

1. Turn MAIN POWER switch on (TM 9-2355-106-10).
2. Raise rear door/ramp and verify door/ramp lock operation (TM 9-2355-106-10).
3. Turn MAIN POWER switch off (TM 9-2355-106-10).
4. Remove wheel chocks (TM 9-2355-106-10).

END OF TASK**END OF WORK PACKAGE**

FIELD MAINTENANCE**A-PILLAR COVER TRIM REMOVAL AND INSTALLATION**

INITIAL SETUP:**Tools and Special Tools**

General Mechanic's Tool Kit (GMTK)
(WP 0795, Item 37)

References

TM 9-2355-106-10
TM 9-2355-106-23P
WP 0786
WP 0782

Equipment Condition

Parking brake set (TM 9-2355-106-10)
Transmission set in NEUTRAL (N) (TM
9-2355-106-10)
Engine off (TM 9-2355-106-10)
MAIN POWER switch off (TM 9-2355-106-10)
Wheels chocked (TM 9-2355-106-10)
A-pillar assist handle removed (WP 0643)

REMOVAL

1. Remove two A-pillar cover trim bolts (Figure 1, Item 2) from A-pillar (Figure 1, Item 1).

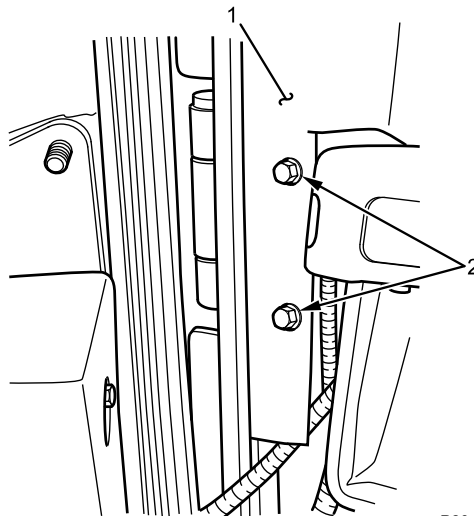

P231800065

Figure 1. A-Pillar Cover Trim Bolts.

A-PILLAR COVER TRIM REMOVAL AND INSTALLATION - (CONTINUED)

2. Remove A-pillar cover trim (Figure 2, Item 1) from A-pillar.

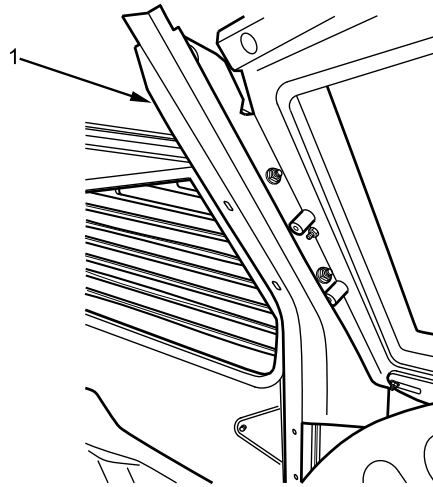

B231801249

Figure 2. A-Pillar Cover Trim.

END OF TASK**INSTALLATION**

1. Position A-pillar cover trim (Figure 3, Item 1) on A-pillar.

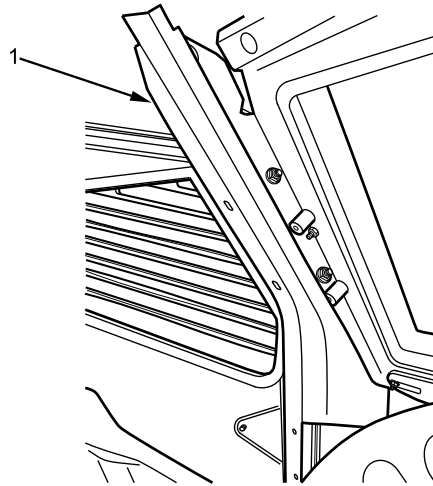

B231801249

Figure 3. A-Pillar Cover Trim.

A-PILLAR COVER TRIM REMOVAL AND INSTALLATION - (CONTINUED)

2. Install two A-pillar cover trim bolts (Figure 4, Item 2) on A-pillar (Figure 4, Item 1). Tighten bolts securely.

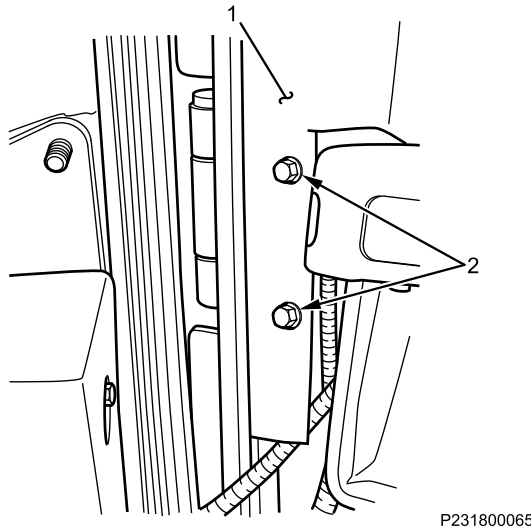

Figure 4. A-Pillar Cover Trim Bolts.

END OF TASK**FOLLOW-ON MAINTENANCE**

1. Install A-pillar assist handle (WP 0643).
2. Remove wheel chocks (TM 9-2355-106-10).

END OF TASK**END OF WORK PACKAGE**

FIELD MAINTENANCE

A-PILLAR ASSIST HANDLE REMOVAL AND INSTALLATION

INITIAL SETUP:

Tools and Special Tools

General Mechanic's Tool Kit (GMTK)
(WP 0795, Item 37)

References

TM 9-2355-106-10
TM 9-2355-106-23P
WP 0786
WP 0782

Equipment Condition

Parking brake set (TM 9-2355-106-10)
Transmission set in NEUTRAL (N) (TM
9-2355-106-10)
Engine off (TM 9-2355-106-10)
MAIN POWER switch off (TM 9-2355-106-10)
Wheels chocked (TM 9-2355-106-10)

REMOVAL

1. Remove two trim bolt covers (Figure 1, Item 3) from A-pillar assist handle (Figure 1, Item 1).

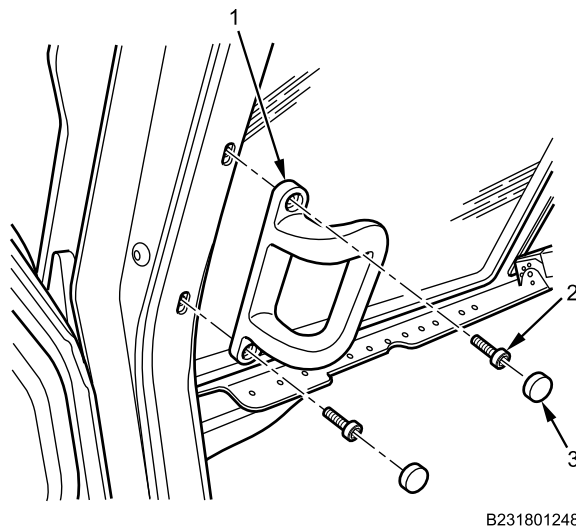

Figure 1. A-Pillar Assist Handle Removal.

2. Remove two bolts (Figure 1, Item 2) from A-pillar assist handle (Figure 1, Item 1) and remove A-pillar assist handle.

END OF TASK

A-PILLAR ASSIST HANDLE REMOVAL AND INSTALLATION - (CONTINUED)**INSTALLATION**

1. Position A-pillar assist handle (Figure 2, Item 1) into position with handle towards center of vehicle and install two A-pillar assist handle bolts (Figure 2, Item 2).

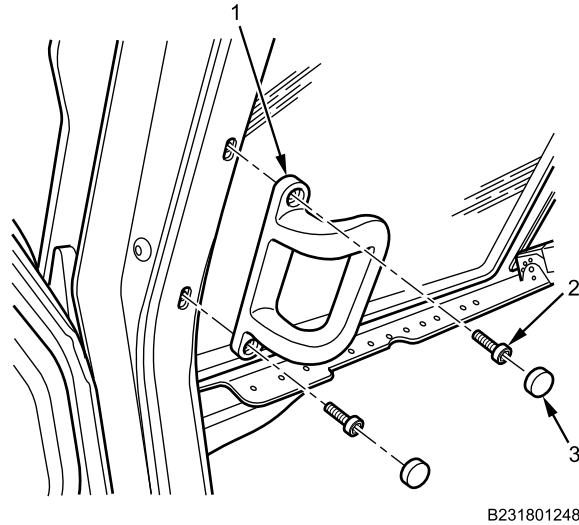

Figure 2. A-Pillar Assist Handle Installation.

2. Tighten two bolts (Figure 2, Item 2) securely.
3. Install two trim bolt covers (Figure 2, Item 3) on A-pillar assist handle (Figure 2, Item 1).

END OF TASK**FOLLOW-ON MAINTENANCE**

1. Remove wheel chocks (TM 9-2355-106-10).

END OF TASK**END OF WORK PACKAGE**

FIELD MAINTENANCE

SIDE COWL BODY ARMOR PANEL REMOVAL AND INSTALLATION

INITIAL SETUP:

Tools and Special Tools

General Mechanic's Tool Kit (GMTK)
(WP 0795, Item 37)
Wrench, torque, click, ratcheting, 15-75 lb-ft, 3/8-inch
drive (WP 0795, Item 145)

TM 9-2355-106-23P

WP 0786

WP 0782

Equipment Condition

Parking brake set (TM 9-2355-106-10)

Transmission set in NEUTRAL (N) (TM
9-2355-106-10)

Engine off (TM 9-2355-106-10)

MAIN POWER switch off (TM 9-2355-106-10)

Wheels chocked (TM 9-2355-106-10)

Fender and reinforcement removed (WP 0657)

Materials/Parts

Compound (WP 0794, Item 13)
Goggles, industrial (WP 0794, Item 20)
Faceshield, industrial (WP 0794, Item 16)
Gloves (WP 0794, Item 18)

References

TM 9-2355-106-10

WARNING

Armor parts are heavy. Use care when removing or installing. Do not attempt to lift without an assistant. Wear gloves. Failure to comply may result in serious injury or death to personnel.

REMOVAL

1. Secure side cowl body armor panel (Figure 1, Item 3) and remove two bolts and washer (Figure 1, Item 1) from antenna bracket (Figure 1, Item 2). Position antenna bracket aside and remove side cowl body armor.

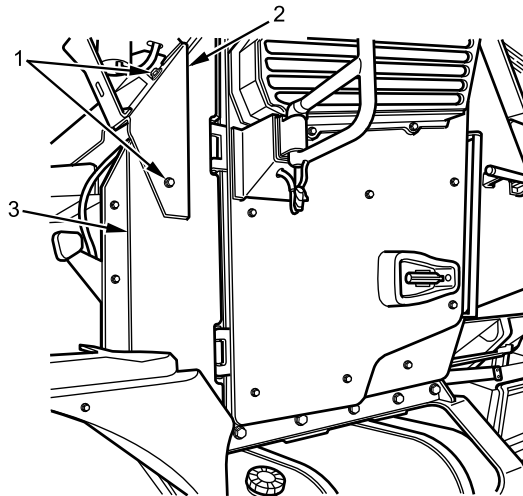

B231802015

Figure 1. Side Cowl Body Armor Panel.

END OF TASK

SIDE COWL BODY ARMOR PANEL REMOVAL AND INSTALLATION - (CONTINUED)

INSTALLATION

WARNING



Corrosion preventive compound is toxic. Use only in well-ventilated area. Do not get in eyes; wear chemical safety goggles and full-face shield when using. Avoid contact with skin and wear rubber or plastic, solvent-resistant gloves. In case of contact, remove contaminated clothing and immediately wash area with soap and water. If compound contacts eyes, flush eyes with large amounts of water for at least 15 minutes and get immediate medical attention. If swallowed, do not induce vomiting; contact a physician immediately. Failure to comply may result in serious injury or death to personnel.

1. Apply corrosion preventive compound on two bolts (Figure 2, Item 1).

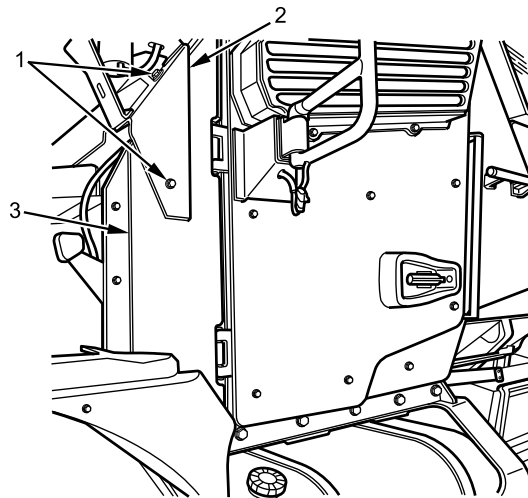

B231802015

Figure 2. Side Cowl Body Armor Panel.

2. Install side cowl body armor panel (Figure 2, Item 3) and antenna bracket (Figure 2, Item 2) with two bolts and washers (Figure 2, Item 1). Using torque wrench, torque bolts to 42 lb-ft (57 N•m).

END OF TASK

FOLLOW-ON MAINTENANCE

1. Install front fender and reinforcement (WP 0657).
2. Remove wheel chocks (TM 9-2355-106-10).

END OF TASK

END OF WORK PACKAGE

FIELD MAINTENANCE
WINDSHIELD ARMOR REMOVAL AND INSTALLATION

INITIAL SETUP:**Tools and Special Tools**

General Mechanic's Tool Kit (GMTK)
(WP 0795, Item 37)

TM 9-2355-106-23P

WP 0782

Materials/Parts

Compound (WP 0794, Item 13)
Sealing compound (WP 0794, Item 42)
Gloves (WP 0794, Item 18)
Goggles, industrial (WP 0794, Item 20)
Faceshield, industrial (WP 0794, Item 16)

Equipment Condition

Parking brake set (TM 9-2355-106-10)
Transmission set in NEUTRAL (N) (TM 9-2355-106-10)
Engine off (TM 9-2355-106-10)
MAIN POWER switch off (TM 9-2355-106-10)
Wheels chocked (TM 9-2355-106-10)
Engine hood open and secured (TM 9-2355-106-10)
Front clearance light removed (WP 0369)
Cowl panel removed (WP 0683)

Personnel Required

Maintainer - (2)

References

TM 9-2355-106-10

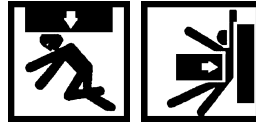
WARNING

Engine hood is extremely heavy and requires two-person lift. Ensure that there is adequate space in front of the vehicle to open hood completely without pinning or pinching personnel between hood and any other structure. Use extreme care when working under hood and make sure it is properly supported. Failure to comply may result in serious injury or death to personnel.

WINDSHIELD ARMOR REMOVAL AND INSTALLATION - (CONTINUED)**REMOVAL****NOTE**

This procedure is the same for left side of vehicle. Right side procedure shown.

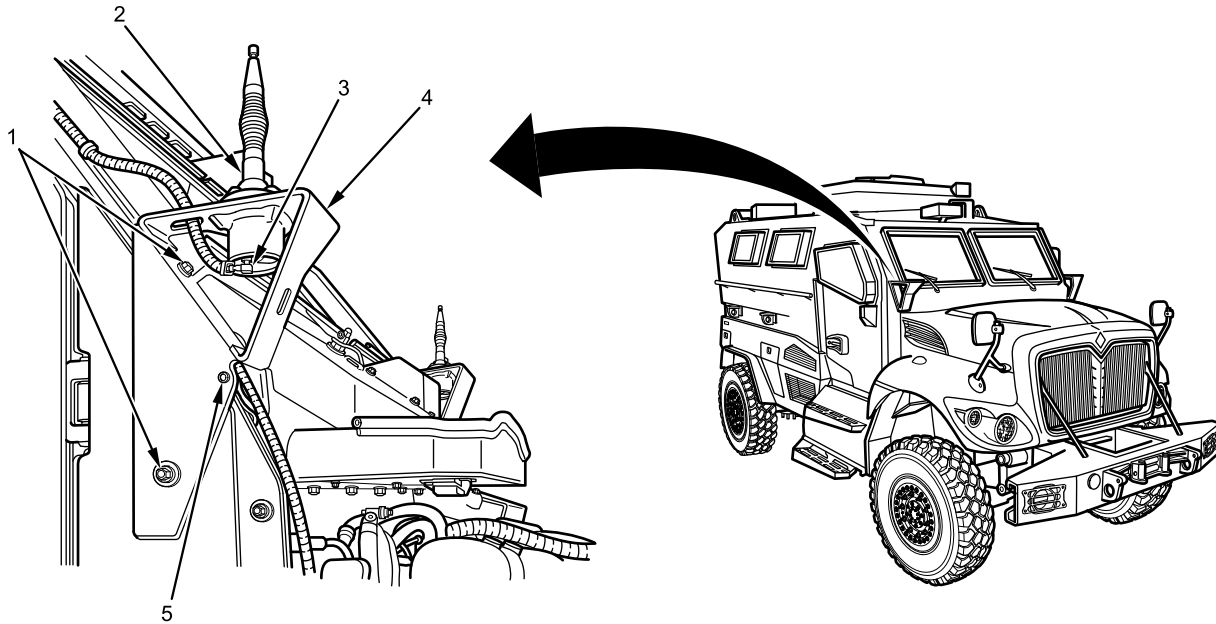

B231806076

Figure 1. Antenna Brackets.

1. Remove sealer, nut, and bolt (Figure 1, Item 5) from antenna ground strap.
2. Disconnect antenna harness (Figure 1, Item 3) from antenna (Figure 1, Item 2).
3. Remove two mounting bolts (Figure 1, Item 1) from antenna bracket (Figure 1, Item 4) and set bracket aside.

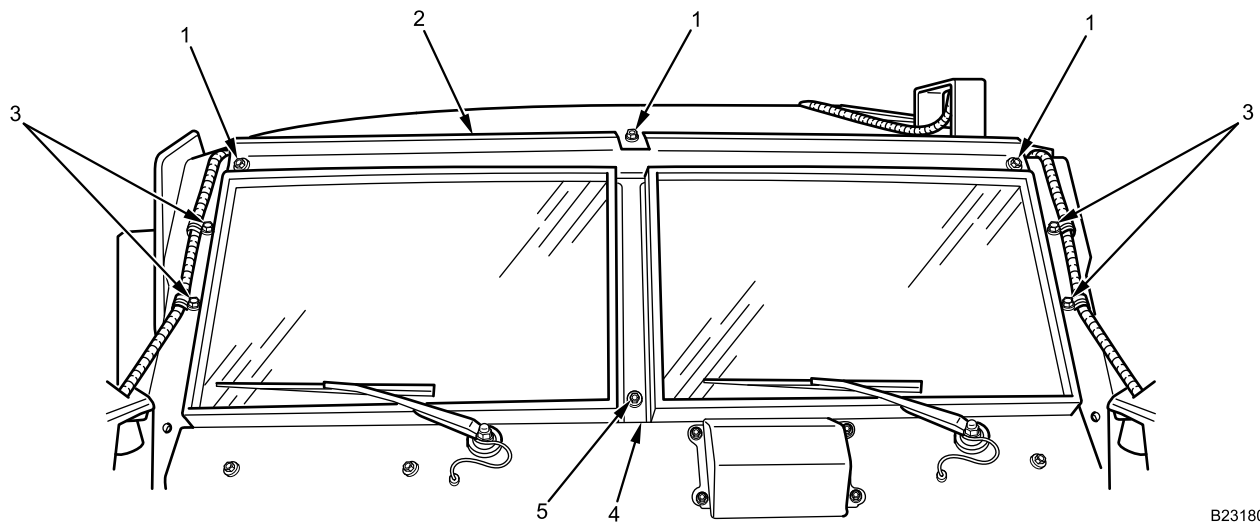
WINDSHIELD ARMOR REMOVAL AND INSTALLATION - (CONTINUED)

B231803470

Figure 2. Windshield Armor and Front Marker Bar.

4. Remove four bolts (Figure 2, Item 3) securing antenna wiring harness retainer. Set antenna wiring harness on top of vehicle.
5. Remove four remaining mounting bolts (Figure 2, Item 1 and 5) that secure front marker bar (Figure 2, Item 2) and windshield armor (Figure 2, Item 4) to vehicle.
6. Remove front marker bar (Figure 2, Item 2).
7. Work windshield armor (Figure 2, Item 4) loose from seated position.
8. With assistant, remove windshield armor (Figure 2, Item 4).

END OF TASK

WINDSHIELD ARMOR REMOVAL AND INSTALLATION - (CONTINUED)

INSTALLATION

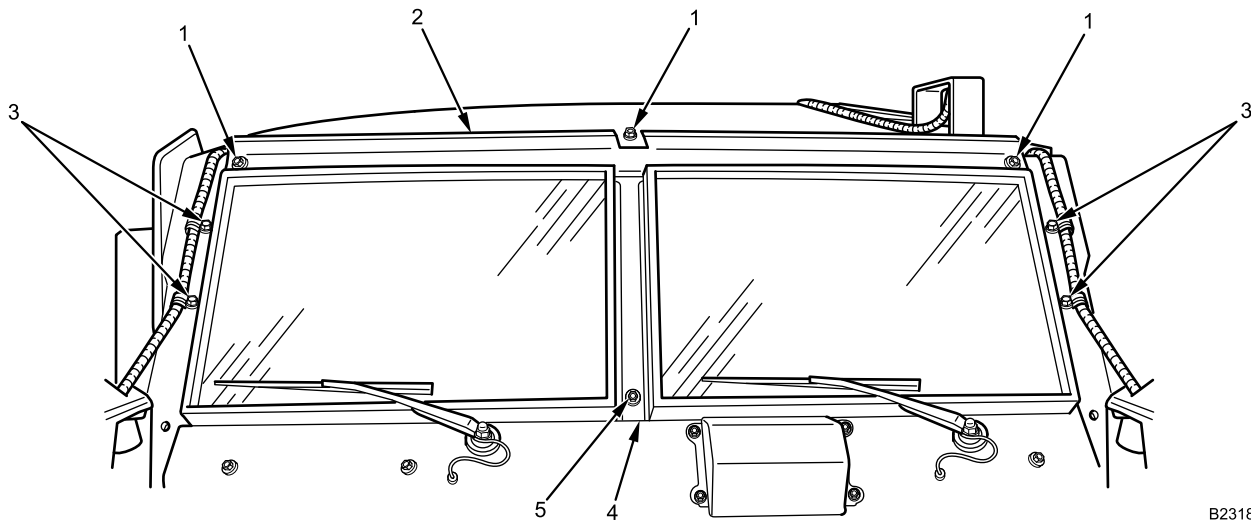

B231803470

Figure 3. Windshield Armor and Front Maker Bar.

WARNING

Corrosion preventive compound is toxic. Use only in well-ventilated area. Do not get in eyes; wear chemical safety goggles and full-face shield when using. Avoid contact with skin and wear rubber or plastic, solvent-resistant gloves. In case of contact, remove contaminated clothing and immediately wash area with soap and water. If compound contacts eyes, flush eyes with large amounts of water for at least 15 minutes and get immediate medical attention. If swallowed, do not induce vomiting; contact a physician immediately. Failure to comply may result in serious injury or death to personnel.

1. Apply corrosion preventive compound on four windshield armor mounting bolts (Figure 3, Item 1 and 5).
2. With assistant, guide windshield armor (Figure 3, Item 3) into position and install mounting bolt (Figure 3, Item 5) loosely.
3. Position front marker bar (Figure 3, Item 2) and loosely install three bolts (Figure 3, Item 1).

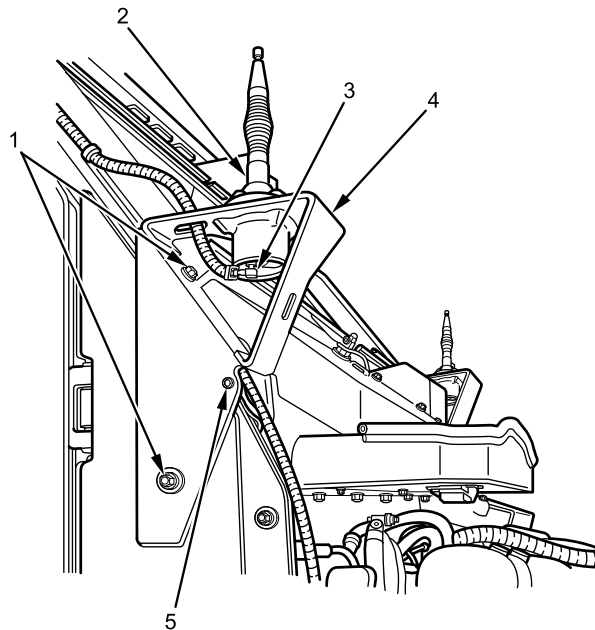
WINDSHIELD ARMOR REMOVAL AND INSTALLATION - (CONTINUED)

B231806075

Figure 4. Antenna Brackets.

4. Install antenna bracket (Figure 4, Item 4) with two mounting bolts (Figure 4, Item 1). Tighten bolts securely.
5. Connect antenna harness (Figure 4, Item 3) to antenna (Figure 4, Item 2).
6. Tighten bolts (Figure 4, Item 1 and 5) securely.
7. Install wiring harness retainers with four bolts (Figure 4, Item 3). Tighten bolts securely.
8. Install antenna ground strap nut and bolt on antenna bracket (Figure 4, Item 5). Tighten bolts securely.
9. Apply sealer to antenna ground strap nuts and bolts (Figure 4, Item 5).

END OF TASK**FOLLOW-ON MAINTENANCE**

1. Install cowl panel (WP 0683).
2. Install front clearance light (WP 0369).
3. Close and secure engine hood (TM 9-2355-106-10).
4. Remove wheel chocks (TM 9-2355-106-10).

END OF TASK**END OF WORK PACKAGE**

FIELD MAINTENANCE
DRIVER CONTROL MOUNTING (DCM) BRACKET ASSEMBLY EXTERIOR ARMOR REMOVAL AND INSTALLATION (WITHOUT FRONT ACCESS PANEL)

INITIAL SETUP:**Tools and Special Tools**

General Mechanic's Tool Kit (GMTK)
 (WP 0795, Item 37)
 Wrench, torque 20-100 lb-ft, 3/8-inch drive
 (WP 0795, Item 141)
 Wrench, torque, dial, 3/8-inch drive, 300 lb-in.
 (WP 0795, Item 147)

TM 9-2355-106-23P

WP 0782

Equipment Condition

Parking brake set (TM 9-2355-106-10)
 Transmission set in NEUTRAL (N) (TM
 9-2355-106-10)
 Engine off (TM 9-2355-106-10)
 MAIN POWER switch off (TM 9-2355-106-10)
 Wheels chocked (TM 9-2355-106-10)
 Engine hood open and secured (TM 9-2355-106-10)
 Air cleaner support bracket removed (WP 0258)

Materials/Parts

Compound (WP 0794, Item 13)
 Goggles, industrial (WP 0794, Item 20)
 Faceshield, industrial (WP 0794, Item 16)

References

TM 9-2355-106-10

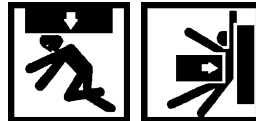
REMOVAL
WARNING

Engine hood is extremely heavy and requires two-person lift. Ensure that there is adequate space in front of the vehicle to open hood completely without pinning or pinching personnel between hood and any other structure. Use extreme care when working under hood and make sure it is properly supported. Failure to comply may result in serious injury or death to personnel.

DRIVER CONTROL MOUNTING (DCM) BRACKET ASSEMBLY EXTERIOR ARMOR REMOVAL AND INSTALLATION (WITHOUT FRONT ACCESS PANEL) - (CONTINUED)

NOTE

Replace DCM bracket assembly exterior armor (without front access panel) with DCM bracket assembly exterior armor (with front access panel).

1. Remove DCM right side exterior armor lower bolt (Figure 1, Item 2) from lower mounting tab (Figure 1, Item 3) and right side exterior armor (Figure 1, Item 1).

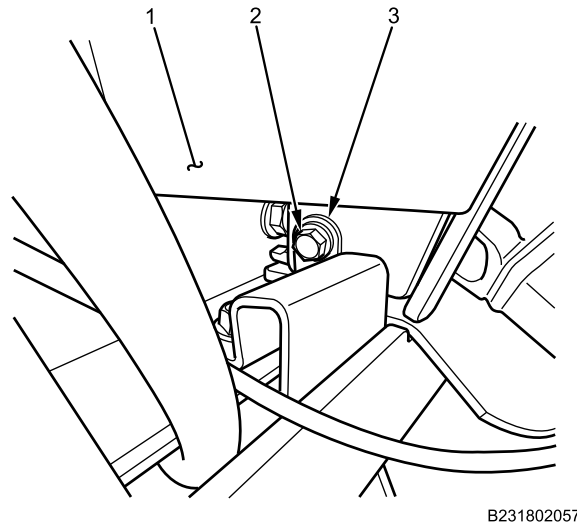

Figure 1. DCM Right Side Exterior Armor Lower Bolt.

2. Remove DCM right side exterior armor upper bolts (Figure 2, Item 1 and 2) and remove DCM right side exterior armor (Figure 2, Item 3).

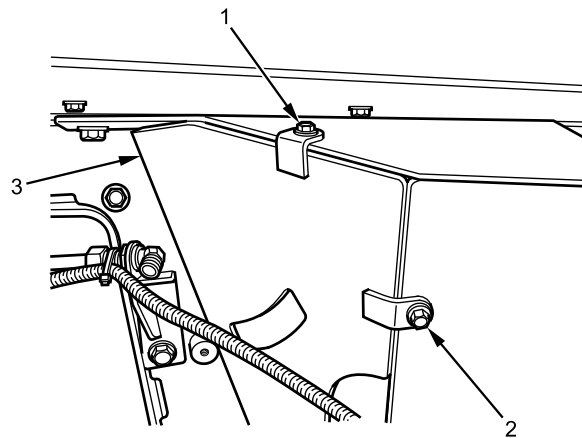

Figure 2. DCM Right Side Exterior Armor Upper Bolts.

3. Remove DCM left side exterior armor lower bolt (Figure 3, Item 3) from wiring harness bracket (Figure 3, Item 2), lower mounting tab (Figure 3, Item 4), and left side exterior armor (Figure 3, Item 1).

DRIVER CONTROL MOUNTING (DCM) BRACKET ASSEMBLY EXTERIOR ARMOR REMOVAL AND INSTALLATION (WITHOUT FRONT ACCESS PANEL) - (CONTINUED)

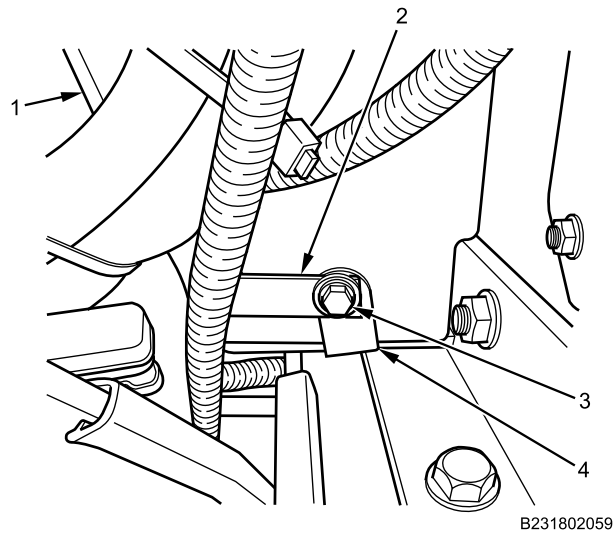

Figure 3. DCM Left Side Exterior Armor Lower Bolt.

DRIVER CONTROL MOUNTING (DCM) BRACKET ASSEMBLY EXTERIOR ARMOR REMOVAL AND INSTALLATION (WITHOUT FRONT ACCESS PANEL) - (CONTINUED)

4. Remove DCM left side exterior armor upper inboard bolts (Figure 4, Item 1 and 3) from DCM left side exterior armor (Figure 4, Item 2).

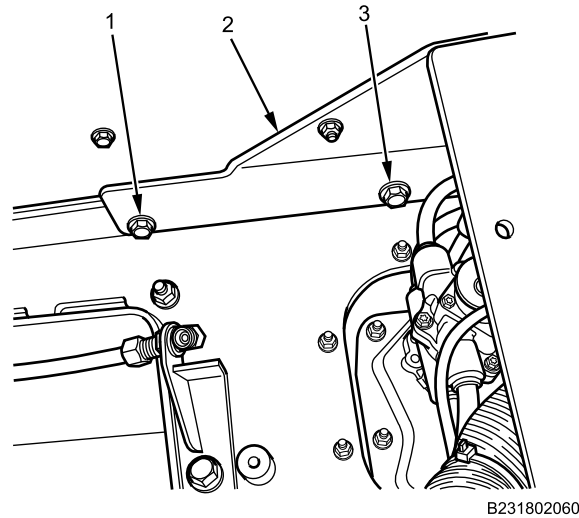

Figure 4. DCM Left Side Exterior Armor Upper Inboard Bolts.

5. Remove DCM left side exterior armor upper outboard bolt (Figure 5, Item 2) and remove DCM left side exterior armor (Figure 5, Item 1).

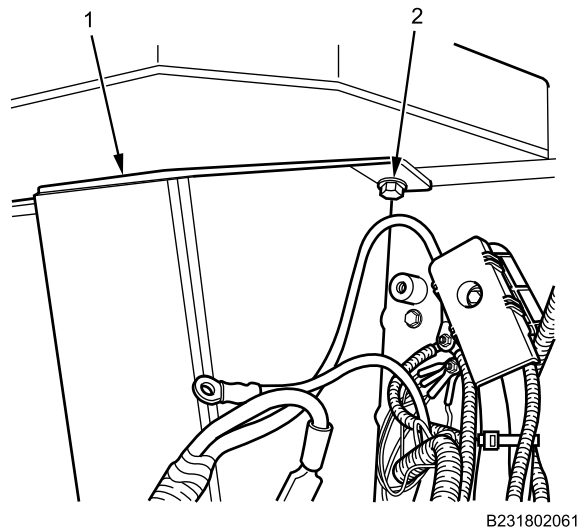

Figure 5. DCM Left Side Exterior Armor Upper Outboard Bolt.

END OF TASK

DRIVER CONTROL MOUNTING (DCM) BRACKET ASSEMBLY EXTERIOR ARMOR REMOVAL AND INSTALLATION (WITHOUT FRONT ACCESS PANEL) - (CONTINUED)**INSTALLATION****WARNING**

Corrosion preventive compound is toxic. Use only in well-ventilated area. Do not get in eyes; wear chemical safety goggles and full-face shield when using. Avoid contact with skin and wear rubber or plastic, solvent-resistant gloves. In case of contact, remove contaminated clothing and immediately wash area with soap and water. If compound contacts eyes, flush eyes with large amounts of water for at least 15 minutes and get immediate medical attention. If swallowed, do not induce vomiting; contact a physician immediately. Failure to comply may result in serious injury or death to personnel.

1. Apply corrosion preventive compound to DCM left side exterior armor upper outboard bolt (Figure 6, Item 2).

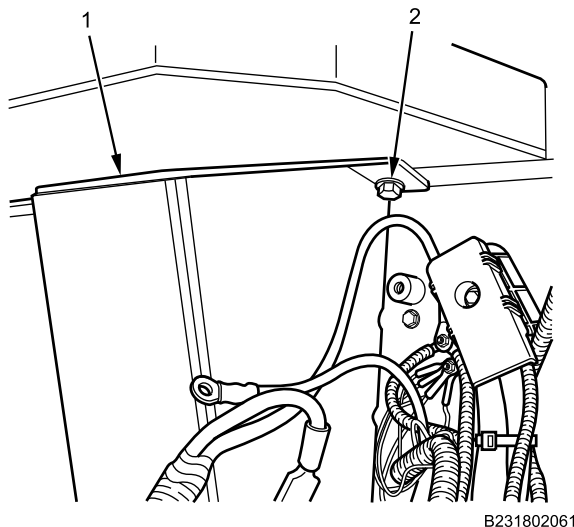

Figure 6. DCM Left Side Exterior Armor Upper Outboard Bolt.

2. Install DCM left side exterior armor (Figure 6, Item 1) and loosely install DCM left side exterior armor upper outboard bolt (Figure 6, Item 2).

DRIVER CONTROL MOUNTING (DCM) BRACKET ASSEMBLY EXTERIOR ARMOR REMOVAL AND INSTALLATION (WITHOUT FRONT ACCESS PANEL) - (CONTINUED)

3. Apply corrosion preventive compound to DCM left side exterior armor upper inboard bolts (Figure 7, Item 1 and 3).

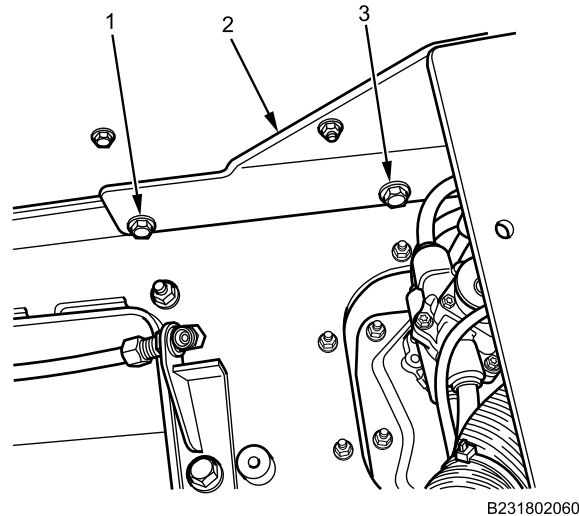

Figure 7. DCM Left Side Exterior Armor Upper Inboard Bolts.

4. Loosely install DCM left side upper exterior armor upper inboard bolts (Figure 7, Item 1 and 3) on DCM left side exterior armor (Figure 7, Item 2).
5. Apply corrosion preventive compound to DCM left side exterior armor lower bolt (Figure 8, Item 3).

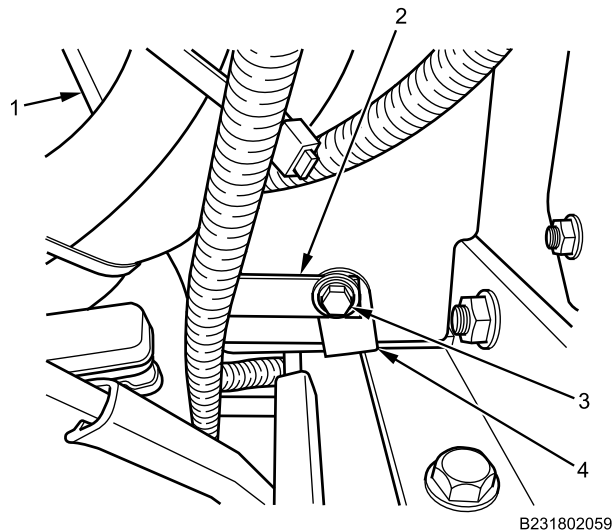
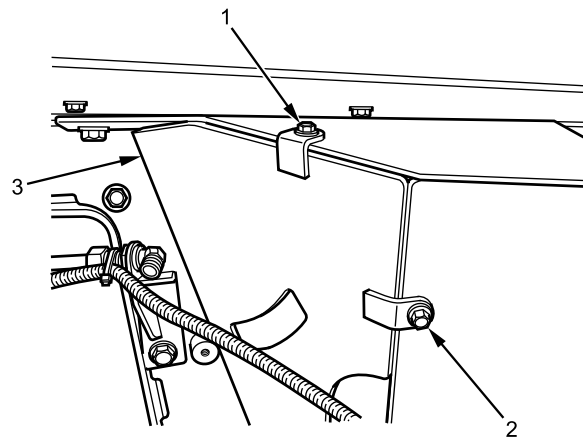

Figure 8. DCM Left Side Exterior Armor Lower Bolt.

6. Loosely install DCM left side exterior armor lower bolt (Figure 8, Item 3) on wiring harness bracket (Figure 8, Item 2), lower mounting tab (Figure 8, Item 4), and left side exterior armor (Figure 8, Item 1).
7. Torque DCM left side exterior armor bolts (Figure 6, Item 2) and (Figure 7, Item 1 and 3) to 67 lb-ft (91 N•m). Torque bolt (Figure 8, Item 3) to 239 lb-in. (27 N•m).
8. Apply corrosion preventive compound to DCM right side exterior armor upper bolts (Figure 9, Item 1 and 2).

DRIVER CONTROL MOUNTING (DCM) BRACKET ASSEMBLY EXTERIOR ARMOR REMOVAL AND INSTALLATION (WITHOUT FRONT ACCESS PANEL) - (CONTINUED)

B231802058

Figure 9. DCM Right Side Exterior Armor Upper Bolts.

9. Install DCM right side exterior armor (Figure 9, Item 3) and loosely install DCM right side exterior armor upper bolts (Figure 9, Item 1 and 2).

DRIVER CONTROL MOUNTING (DCM) BRACKET ASSEMBLY EXTERIOR ARMOR REMOVAL AND INSTALLATION (WITHOUT FRONT ACCESS PANEL) - (CONTINUED)

10. Apply corrosion preventive compound to DCM right side exterior armor lower bolt (Figure 10, Item 2).

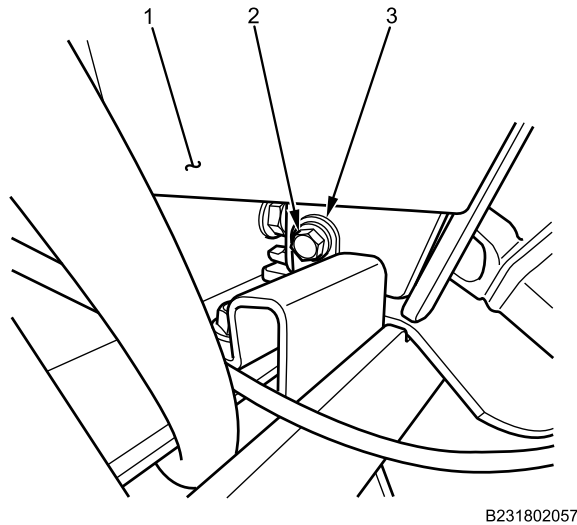

Figure 10. DCM Right Side Exterior Armor Lower Bolt.

11. Loosely install DCM right side lower exterior armor bolt (Figure 10, Item 2) on lower mounting tab (Figure 10, Item 3) and right side exterior armor (Figure 10, Item 1).
12. Torque DCM right side exterior armor bolts (Figure 9, Item 1 and 2) and (Figure 10, Item 2) to 239 lb-in. (27 N•m).

END OF TASK**FOLLOW-ON MAINTENANCE**

1. Install air cleaner support bracket (WP 0258).
2. Close engine hood (TM 9-2355-106-10).
3. Remove wheel chocks (TM 9-2355-106-10).

END OF TASK**END OF WORK PACKAGE**

FIELD MAINTENANCE
DRIVER CONTROL MOUNTING (DCM) BRACKET ASSEMBLY EXTERIOR ARMOR REMOVAL AND INSTALLATION (WITH FRONT ACCESS PANEL)

INITIAL SETUP:**Tools and Special Tools**

General Mechanic's Tool Kit (GMTK)
(WP 0795, Item 37)

WP 0786

WP 0782

Materials/Parts

Compound (WP 0794, Item 13)
Goggles, industrial (WP 0794, Item 20)
Faceshield, industrial (WP 0794, Item 16)
Lockbolt (WP 0796, Item 131)
Locknut (WP 0796, Item 29)

Equipment Condition

Parking brake set (TM 9-2355-106-10)
Transmission set in NEUTRAL (N) (TM 9-2355-106-10)
Engine off (TM 9-2355-106-10)
MAIN POWER switch off (TM 9-2355-106-10)
Wheels chocked (TM 9-2355-106-10)
Engine hood open and secured (TM 9-2355-106-10)
Air tanks drained (TM 9-2355-106-10)
Air cleaner support bracket removed (WP 0258)

References

TM 9-2355-106-10
TM 9-2355-106-23P

WARNING

Engine hood is extremely heavy and requires two-person lift. Ensure that there is adequate space in front of the vehicle to open hood completely without pinning or pinching personnel between hood and any other structure. Use extreme care when working under hood and make sure it is properly supported. Failure to comply may result in serious injury or death to personnel.

DRIVER CONTROL MOUNTING (DCM) BRACKET ASSEMBLY EXTERIOR ARMOR REMOVAL AND INSTALLATION (WITH FRONT ACCESS PANEL) - (CONTINUED)**REMOVAL**

1. Remove five DCM front access cover armor bolts (Figure 1, Item 3) from DCM front access cover armor (Figure 1, Item 2) and DCM bracket assembly exterior armor (Figure 1, Item 1).

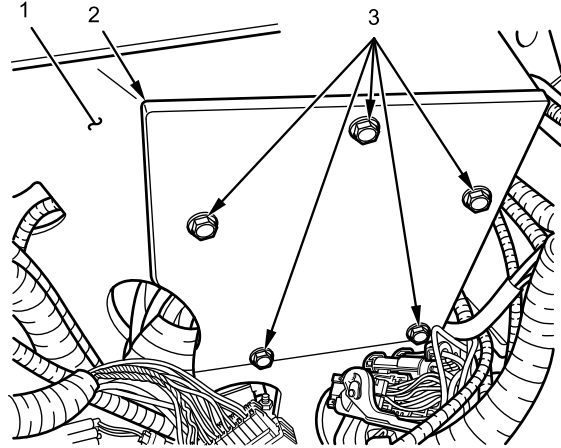

P231800633

Figure 1. DCM Front Access Cover Armor Bolts.

CAUTION

Do not allow steering wheel to turn when steering shaft is removed, or clock spring damage may result.

2. Disconnect air lines in harness (Figure 2, Item 1) from foot brake valve (Figure 2, Item 2), tractor protection valve (Figure 2, Item 3), and door air supply line (Figure 2, Item 6) from tee (Figure 2, Item 5).

DRIVER CONTROL MOUNTING (DCM) BRACKET ASSEMBLY EXTERIOR ARMOR REMOVAL AND INSTALLATION (WITH FRONT ACCESS PANEL) - (CONTINUED)

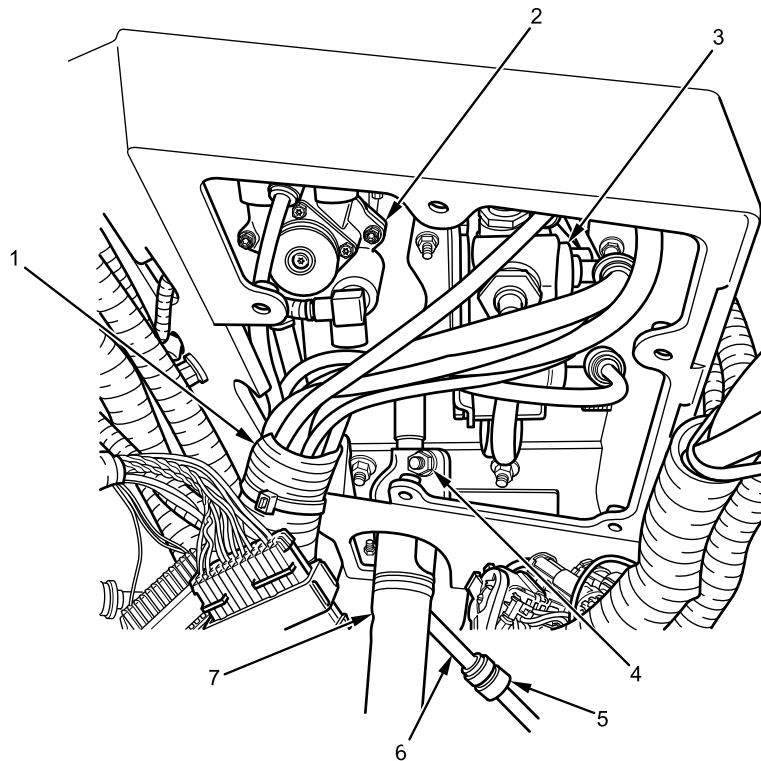

B231810614

Figure 2. Air Lines and Steering Column Lockbolt.

3. Remove upper lockbolt (Figure 2, Item 4) and locknut from steering shaft (Figure 2, Item 7) and position shaft aside. Discard lockbolt (Figure 2, Item 4) and locknut.
4. Disconnect small BLACK air line (Figure 3, Item 1) from angle fitting in foot brake valve (Figure 3, Item 2).

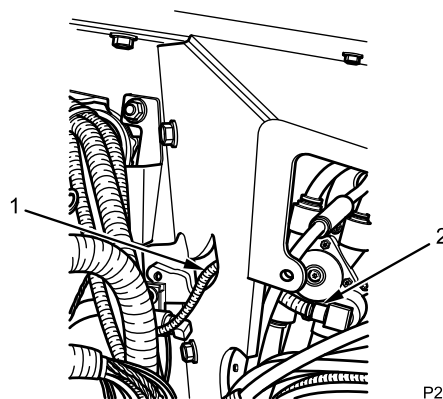

P231801051

Figure 3. Air Line.

5. Remove air line (Figure 3, Item 1) from exterior armor.
6. Remove exterior armor inboard bolts (Figure 4, Item 1 and 3) and washers from exterior armor (Figure 4, Item 2).

DRIVER CONTROL MOUNTING (DCM) BRACKET ASSEMBLY EXTERIOR ARMOR REMOVAL AND INSTALLATION (WITH FRONT ACCESS PANEL) - (CONTINUED)

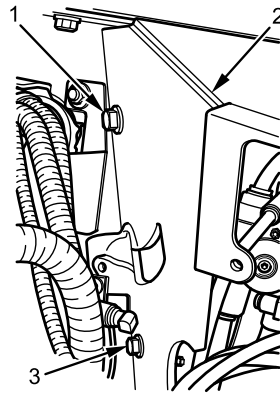

P231800635

Figure 4. Exterior Armor Inboard Bolts.

7. Position Power Distribution Center (PDC) (Figure 5, Item 1) away from exterior armor (Figure 5, Item 2).

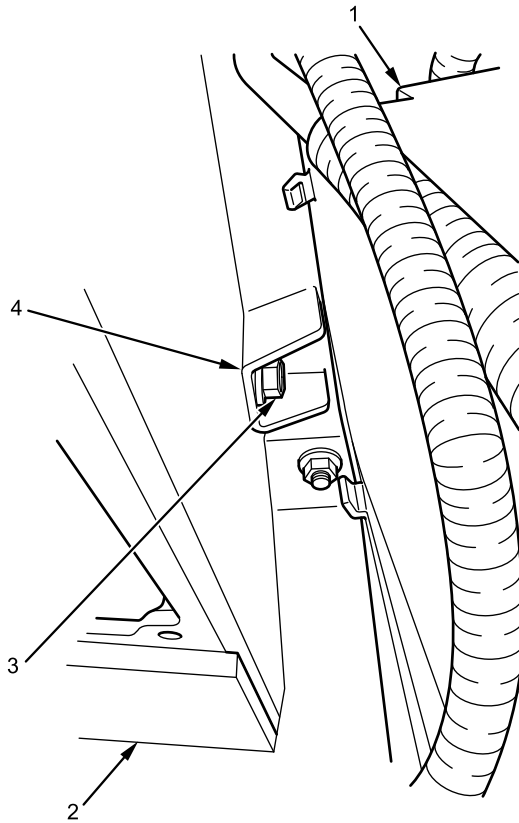

P231800636

Figure 5. Exterior Armor Outboard Lower Bolt.

8. Remove armor outboard lower bolt (Figure 5, Item 3) from firewall bracket (Figure 5, Item 4) and exterior armor (Figure 5, Item 2).

DRIVER CONTROL MOUNTING (DCM) BRACKET ASSEMBLY EXTERIOR ARMOR REMOVAL AND INSTALLATION (WITH FRONT ACCESS PANEL) - (CONTINUED)

9. Remove armor outboard upper bolt (Figure 6, Item 2) from firewall bracket (Figure 6, Item 3) and exterior armor (Figure 6, Item 1). Remove exterior armor.

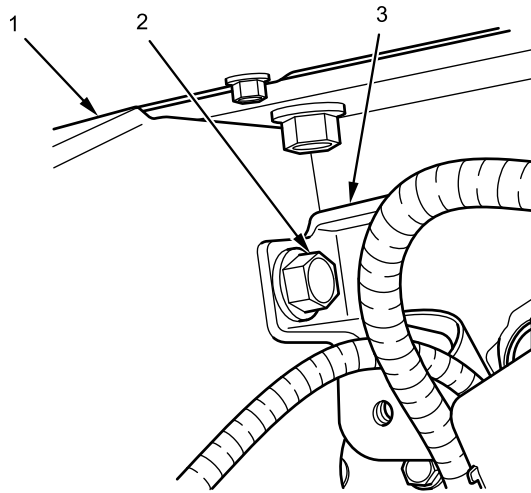

P231800637

Figure 6. Exterior Armor Outboard Upper Bolt.

END OF TASK**DISASSEMBLY**

1. Remove two bolts (Figure 7, Item 3) and bottom cover (Figure 7, Item 2) from exterior armor (Figure 7, Item 1).

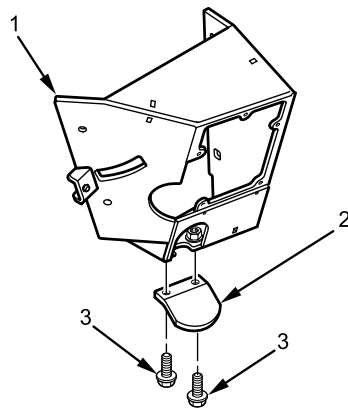

B231810613

Figure 7. Exterior Armor Bottom Cover.

END OF TASK

DRIVER CONTROL MOUNTING (DCM) BRACKET ASSEMBLY EXTERIOR ARMOR REMOVAL AND INSTALLATION (WITH FRONT ACCESS PANEL) - (CONTINUED)**ASSEMBLY****WARNING**

Corrosion preventive compound is toxic. Use only in well-ventilated area. Do not get in eyes; wear chemical safety goggles and full-face shield when using. Avoid contact with skin and wear rubber or plastic, solvent-resistant gloves. In case of contact, remove contaminated clothing and immediately wash area with soap and water. If compound contacts eyes, flush eyes with large amounts of water for at least 15 minutes and get immediate medical attention. If swallowed, do not induce vomiting; contact a physician immediately. Failure to comply may result in serious injury or death to personnel.

1. Apply corrosion preventive compound to exterior armor bottom cover bolts (Figure 8, Item 3).

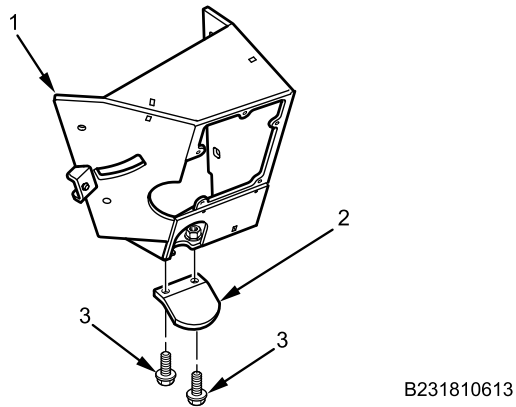

Figure 8. Exterior Armor Bottom Cover.

2. Install two bolts (Figure 8, Item 3) and bottom cover (Figure 8, Item 2) on exterior armor (Figure 8, Item 1). Tighten bolts securely.

END OF TASK

DRIVER CONTROL MOUNTING (DCM) BRACKET ASSEMBLY EXTERIOR ARMOR REMOVAL AND INSTALLATION (WITH FRONT ACCESS PANEL) - (CONTINUED)**INSTALLATION****WARNING**

Corrosion preventive compound is toxic. Use only in well-ventilated area. Do not get in eyes; wear chemical safety goggles and full-face shield when using. Avoid contact with skin and wear rubber or plastic, solvent-resistant gloves. In case of contact, remove contaminated clothing and immediately wash area with soap and water. If compound contacts eyes, flush eyes with large amounts of water for at least 15 minutes and get immediate medical attention. If swallowed, do not induce vomiting; contact a physician immediately. Failure to comply may result in serious injury or death to personnel.

1. Apply corrosion preventive compound to exterior armor outboard upper bolt (Figure 9, Item 2).

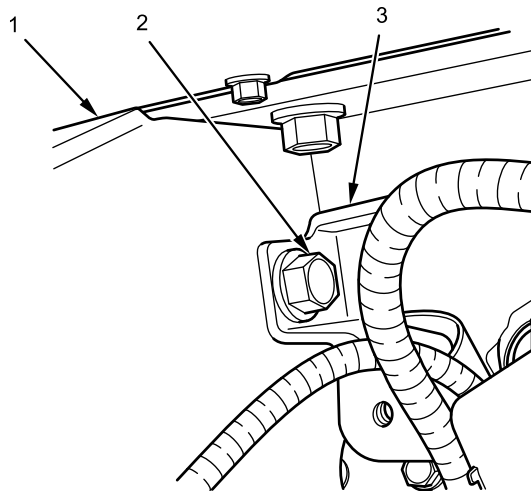

P231800637

Figure 9. Exterior Armor Outboard Upper Bolt.

2. Install exterior armor (Figure 9, Item 1) and loosely install exterior armor outboard upper bolt (Figure 9, Item 2) on firewall bracket (Figure 9, Item 3).
3. Apply corrosion preventive compound to exterior armor outboard lower bolt (Figure 10, Item 3).

DRIVER CONTROL MOUNTING (DCM) BRACKET ASSEMBLY EXTERIOR ARMOR REMOVAL AND INSTALLATION (WITH FRONT ACCESS PANEL) - (CONTINUED)

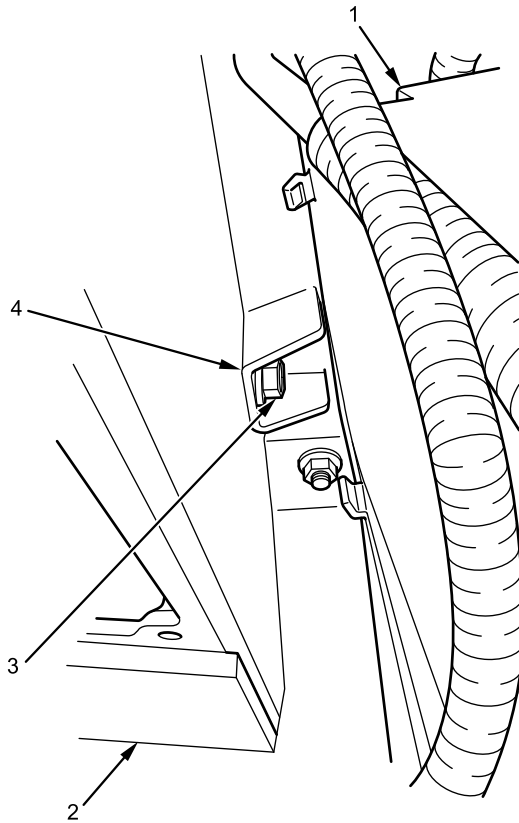

P231800636

Figure 10. Exterior Armor Outboard Lower Bolt.

4. Loosely install exterior armor outboard lower bolt (Figure 10, Item 3) on firewall bracket (Figure 10, Item 4) and exterior armor (Figure 10, Item 2) behind PDC (Figure 10, Item 1).
5. Apply corrosion preventive compound to exterior armor inboard bolts (Figure 11, Item 1 and 3).

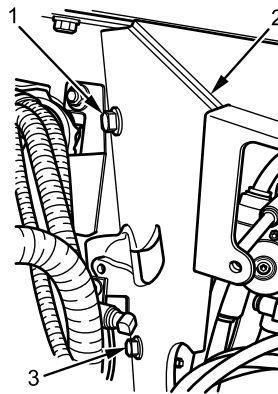

P231800635

Figure 11. Exterior Armor Inboard Bolts.

6. Install exterior armor inboard bolts (Figure 11, Item 1 and 3) on exterior armor (Figure 11, Item 2).
7. Tighten all exterior armor inboard and outboard bolts securely.
8. Connect small BLACK air line (Figure 12, Item 1) to angle fitting in foot brake valve (Figure 12, Item 2).

DRIVER CONTROL MOUNTING (DCM) BRACKET ASSEMBLY EXTERIOR ARMOR REMOVAL AND INSTALLATION (WITH FRONT ACCESS PANEL) - (CONTINUED)

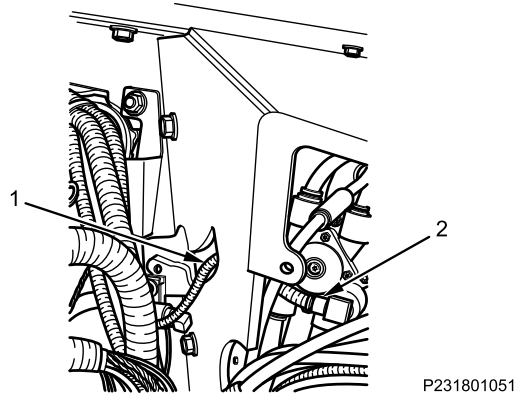

Figure 12. Air Line.

9. Position steering shaft (Figure 13, Item 7) on steering column, and install new lockbolt (Figure 13, Item 4) and new locknut. Tighten locknut securely.

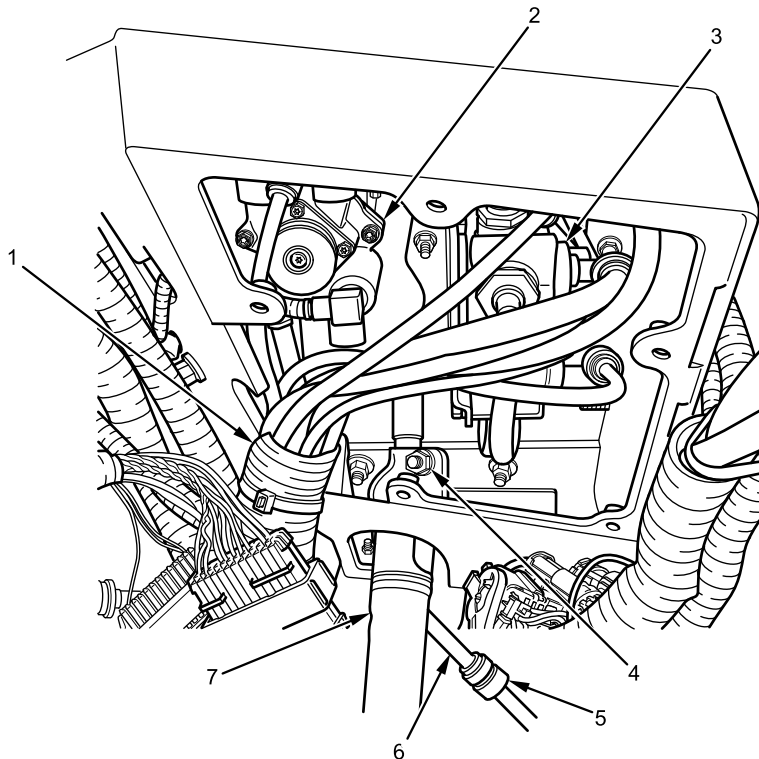
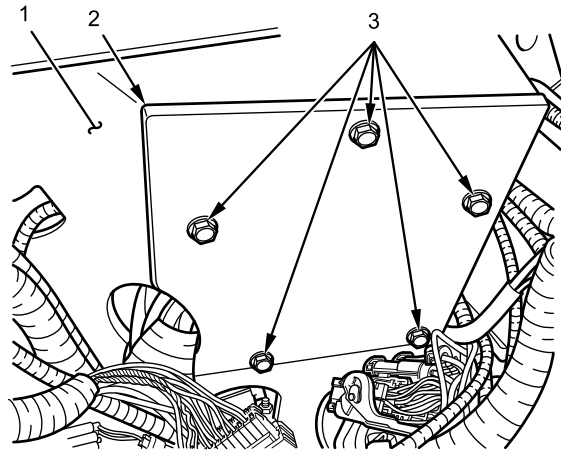

Figure 13. Air Lines and Steering Column Pinch Bolt.

10. Connect air lines in harness (Figure 13, Item 1) to foot brake valve (Figure 13, Item 2), tractor protection valve (Figure 13, Item 3), and door air supply line (Figure 13, Item 6) to tee (Figure 13, Item 5).
11. Apply corrosion preventive compound to five front access cover armor bolts (Figure 14, Item 3).

DRIVER CONTROL MOUNTING (DCM) BRACKET ASSEMBLY EXTERIOR ARMOR REMOVAL AND INSTALLATION (WITH FRONT ACCESS PANEL) - (CONTINUED)



P231800633

Figure 14. DCM Front Access Cover Armor Bolts.

12. Install five front access cover armor bolts (Figure 14, Item 3) on front access cover armor (Figure 14, Item 2) and exterior armor (Figure 14, Item 1). Tighten bolts securely.

END OF TASK

FOLLOW-ON MAINTENANCE

1. Install air cleaner support bracket (WP 0258).
2. Turn MAIN POWER switch on (TM 9-2355-106-10).
3. Start engine and allow air system pressure to build to normal range (TM 9-2355-106-10).
4. Observe instrument panel gauges to verify proper air pressure (TM 9-2355-106-10).
5. Check for leaks (TM 9-2355-106-10).
6. Shut engine off (TM 9-2355-106-10).
7. Close engine hood (TM 9-2355-106-10).
8. Remove wheel chocks (TM 9-2355-106-10).

END OF TASK

END OF WORK PACKAGE

FIELD MAINTENANCE

DRIVER CONTROL MOUNTING (DCM) BRACKET ASSEMBLY INTERIOR ARMOR REMOVAL AND INSTALLATION

INITIAL SETUP:

Tools and Special Tools

General Mechanic's Tool Kit (GMTK)
(WP 0795, Item 37)

TM 9-2355-106-23P

WP 0782

Materials/Parts

Compound (WP 0794, Item 13)
Goggles, industrial (WP 0794, Item 20)
Faceshield, industrial (WP 0794, Item 16)
Gloves (WP 0794, Item 18)
Grease (WP 0794, Item 22)

Equipment Condition

Parking brake set (TM 9-2355-106-10)
Transmission set in NEUTRAL (N) (TM 9-2355-106-10)
Engine off (TM 9-2355-106-10)
MAIN POWER switch off (TM 9-2355-106-10)
Wheels chocked (TM 9-2355-106-10)
Battery cables disconnected (WP 0404)
DCM exterior armor removed (WP 0646)

Personnel Required

Maintainer (2)

References

TM 9-2355-106-10

REMOVAL

1. Disconnect instrument panel harness connector 1600 (Figure 1, Item 2) from ESC module (Figure 1, Item 1) under driver side of instrument panel.

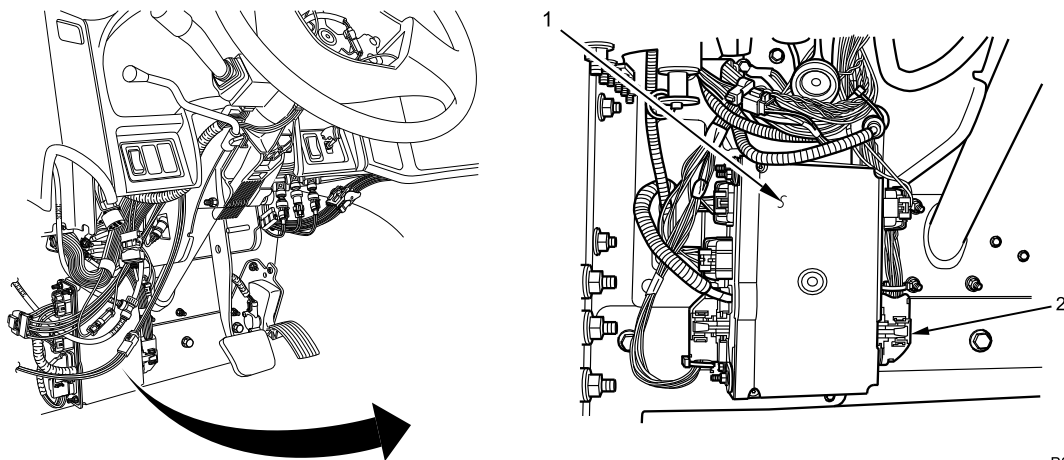

B231810860

Figure 1. Electronic System Controller (ESC) Module Connector.

DRIVER CONTROL MOUNTING (DCM) BRACKET ASSEMBLY INTERIOR ARMOR REMOVAL AND INSTALLATION - (CONTINUED)

2. With assistant, remove two bolts and nuts (Figure 2, Item 2 and 3) and interior armor (Figure 2, Item 1).

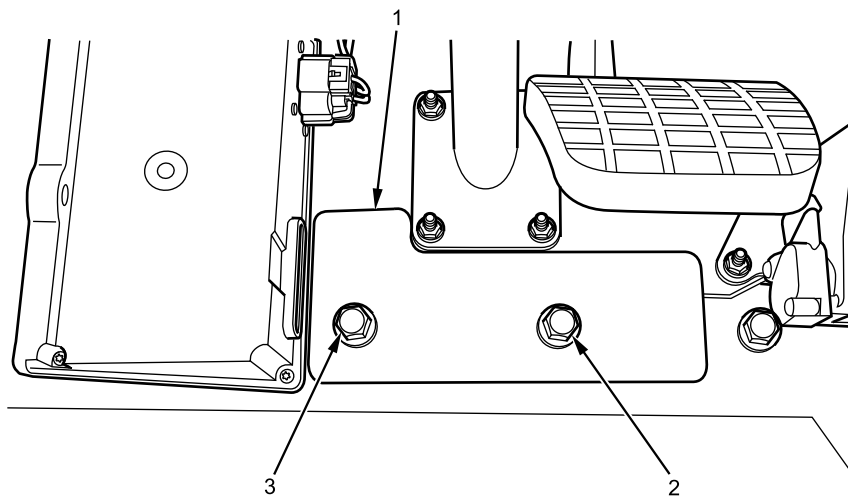

B231801524

Figure 2. DCM Bracket Assembly Interior Armor.

END OF TASK

DRIVER CONTROL MOUNTING (DCM) BRACKET ASSEMBLY INTERIOR ARMOR REMOVAL AND INSTALLATION - (CONTINUED)**INSTALLATION****WARNING**

Corrosion preventive compound is toxic. Use only in well-ventilated area. Do not get in eyes; wear chemical safety goggles and full-face shield when using. Avoid contact with skin and wear rubber or plastic, solvent-resistant gloves. In case of contact, remove contaminated clothing and immediately wash area with soap and water. If compound contacts eyes, flush eyes with large amounts of water for at least 15 minutes and get immediate medical attention. If swallowed, do not induce vomiting; contact a physician immediately. Failure to comply may result in serious injury or death to personnel.

1. Apply corrosion preventive compound to two bolts and nuts (Figure 3, Item 2 and 3).

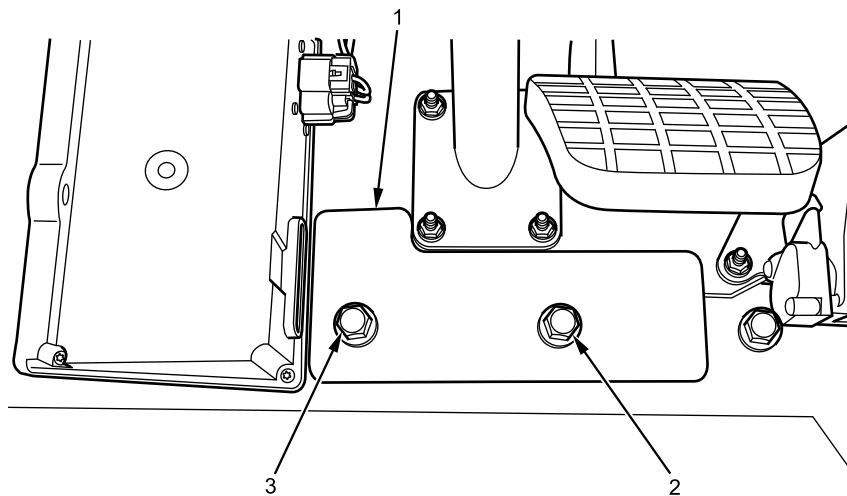

B231801524

Figure 3. DCM Bracket Assembly Interior Armor.

2. With assistant, install DCM bracket assembly interior armor (Figure 3, Item 1) with two bolts and nuts (Figure 3, Item 2 and 3). Tighten nuts securely.

DRIVER CONTROL MOUNTING (DCM) BRACKET ASSEMBLY INTERIOR ARMOR REMOVAL AND INSTALLATION - (CONTINUED)

WARNING



Dielectric grease is harmful to skin and eyes. If grease contacts eyes, rinse thoroughly and contact physician if irritation persists. If skin is contacted, wash thoroughly with soap and water. Failure to comply may result in serious injury to personnel.

3. Apply dielectric grease in instrument panel harness connector 1600 (Figure 4, Item 2).

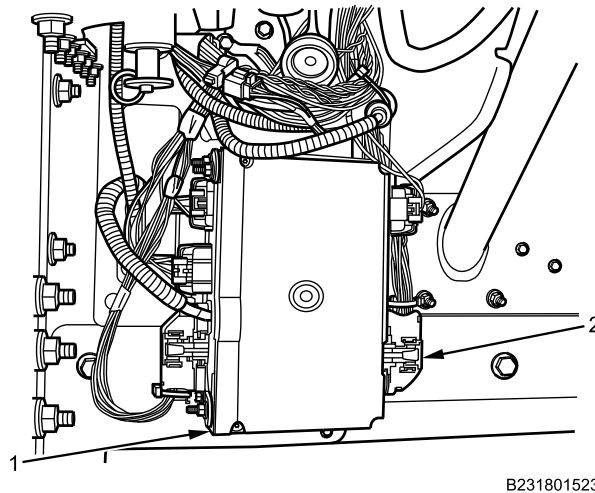

Figure 4. ESC Module Connector.

4. Connect instrument panel harness connector 1600 (Figure 4, Item 2) to ESC module (Figure 4, Item 1).

END OF TASK

FOLLOW-ON MAINTENANCE

1. Install DCM exterior armor (WP 0646).
2. Connect battery cables (WP 0404).
3. Turn MAIN POWER switch on (TM 9-2355-106-10).
4. Remove wheel chocks (TM 9-2355-106-10).
5. Test-drive vehicle to verify ESC module operation (TM 9-2355-106-10).
6. Set vehicle parking brake (TM 9-2355-106-10).
7. Set transmission in NEUTRAL (N) (TM 9-2355-106-10).
8. Turn engine off (TM 9-2355-106-10).
9. Turn MAIN POWER switch off (TM 9-2355-106-10).

END OF TASK

END OF WORK PACKAGE

FIELD MAINTENANCE

ENGINE COVER REMOVAL AND INSTALLATION

INITIAL SETUP:

Tools and Special Tools

General Mechanic's Tool Kit (GMTK)
(WP 0795, Item 37)

TM 9-2355-106-23P

WP 0782

Materials/Parts

Cleaning compound, solvent (WP 0794, Item 10)
Gloves (WP 0794, Item 18)
Goggles, industrial (WP 0794, Item 20)
Faceshield, industrial (WP 0794, Item 16)
Seal (WP 0796, Item 146)

Equipment Condition

Parking brake set (TM 9-2355-106-10)
Transmission set in NEUTRAL (N) (TM 9-2355-106-10)
Engine off (TM 9-2355-106-10)
MAIN POWER switch off (TM 9-2355-106-10)
Wheels chocked (TM 9-2355-106-10)
24V Power Distribution Module (PDM) removed (WP 0443)

References

TM 9-2355-106-10

REMOVAL

1. Remove 17 bolts (Figure 1, Item 4) and engine cover (Figure 1, Item 3) from underbody assembly (Figure 1, Item 1).

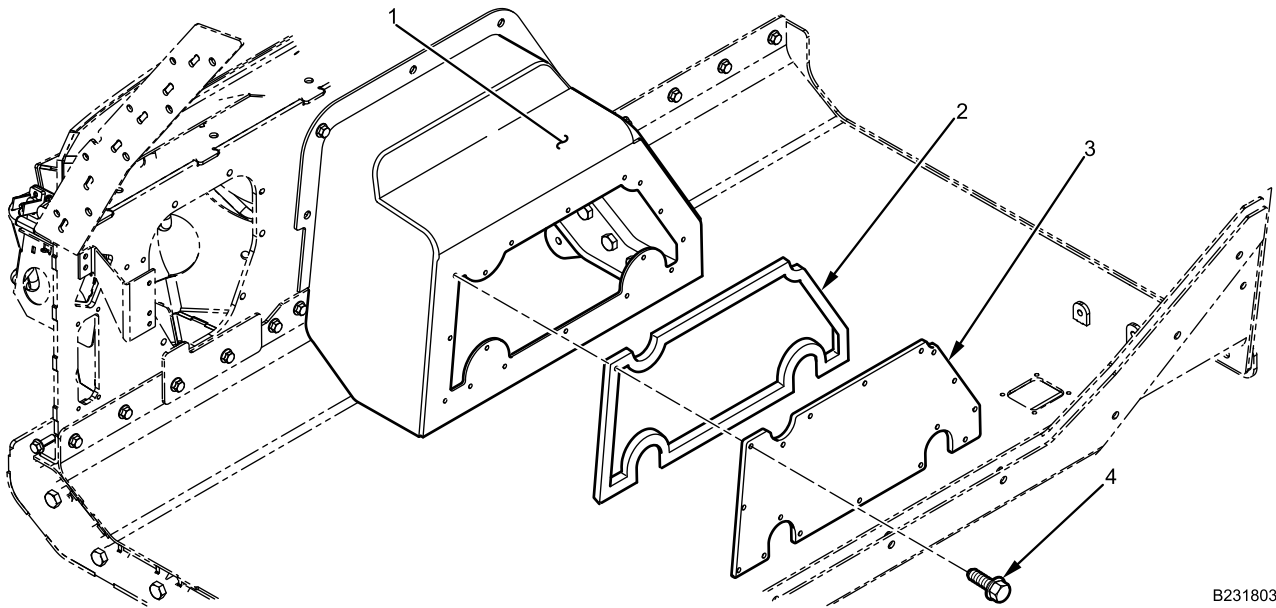

B231803669

Figure 1. Engine Cover Removal.

2. Remove engine cover seal (Figure 1, Item 2) from engine cover (Figure 1, Item 3).

ENGINE COVER REMOVAL AND INSTALLATION - (CONTINUED)**WARNING**

Adhesives, solvents, and sealing compounds can burn easily, can give off harmful vapors, and are harmful to skin and clothing. Wear goggles and protective clothing. Keep away from open flame and use in well-ventilated area. If adhesive, solvent, or sealing compound get on skin or clothing, wash immediately with soap and water. Failure to comply may result in injury or death to personnel.

3. Clean engine cover sealing surface with cleaning solvent.

END OF TASK**INSTALLATION**

1. Position new seal (Figure 2, Item 2) on engine cover (Figure 2, Item 3).

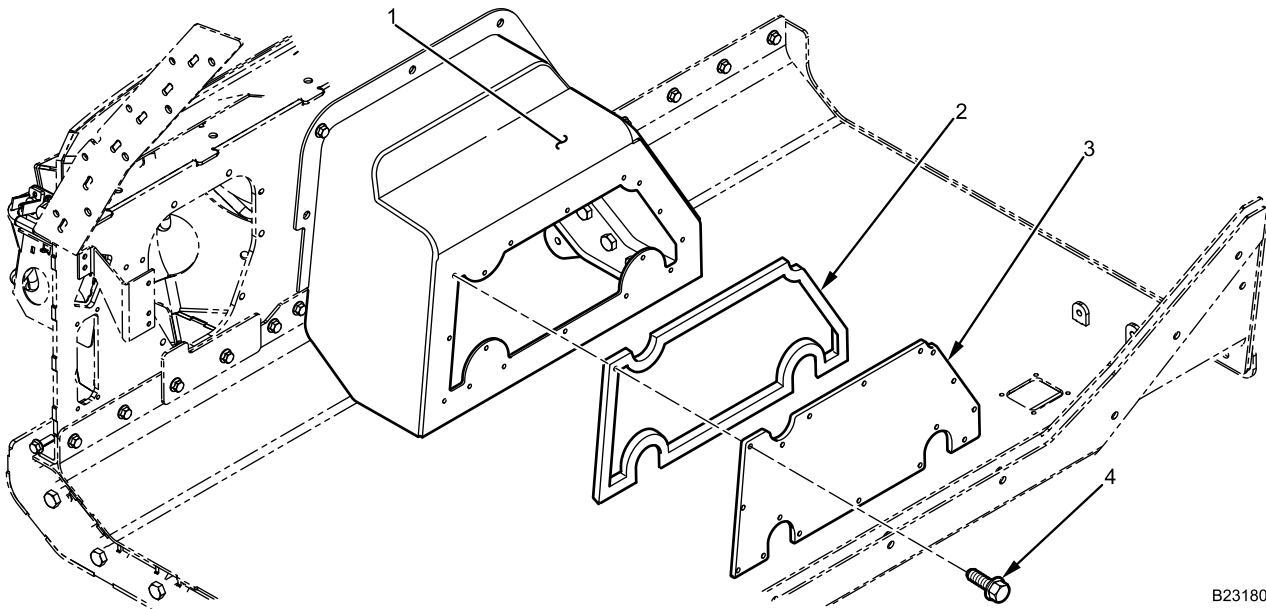

B231803669

Figure 2. Engine Cover Installation.

2. Install engine cover (Figure 2, Item 3) on underbody assembly (Figure 2, Item 1) with 17 bolts (Figure 2, Item 4). Tighten engine cover bolts securely.

END OF TASK

ENGINE COVER REMOVAL AND INSTALLATION - (CONTINUED)**FOLLOW-ON MAINTENANCE**

1. Install 24V PDM (WP 0443).
2. Turn MAIN POWER switch on (TM 9-2355-106-10).
3. Start vehicle, ensure proper operation (TM 9-2355-106-10).
4. Set parking brake (TM 9-2355-106-10).
5. Set transmission in NEUTRAL (N) (TM 9-2355-106-10).
6. Turn engine off (TM 9-2355-106-10).
7. Turn MAIN POWER switch off (TM 9-2355-106-10).
8. Remove wheel chocks (TM 9-2355-106-10).

END OF TASK**END OF WORK PACKAGE**

FIELD MAINTENANCE**COWL PANEL DRAIN TUBE REMOVAL AND INSTALLATION**

INITIAL SETUP:**Tools and Special Tools**

General Mechanic's Tool Kit (GMTK)
(WP 0795, Item 37)

References

TM 9-2355-106-10
TM 9-2355-106-23P
WP 0786
WP 0782

Equipment Condition

Parking brake set (TM 9-2355-106-10)
Transmission set in NEUTRAL (N) (TM
9-2355-106-10)
Engine off (TM 9-2355-106-10)
MAIN POWER switch off (TM 9-2355-106-10)
Wheels chocked (TM 9-2355-106-10)
Hood opened (TM 9-2355-106-10)

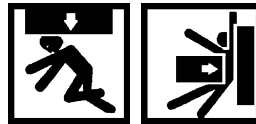
REMOVAL**WARNING**

Engine hood is extremely heavy and requires two-person lift. Ensure that there is adequate space in front of the vehicle to open hood completely without pinning or pinching personnel between hood and any other structure. Use extreme care when working under hood and make sure it is properly supported. Failure to comply may result in serious injury or death to personnel.

COWL PANEL DRAIN TUBE REMOVAL AND INSTALLATION - (CONTINUED)

1. Remove two screws, washers (Figure 1, Item 2), and metal band (Figure 1, Item 3) from cowl drain tube (Figure 1, Item 4) mounted under cowl panel (Figure 1, Item 1).

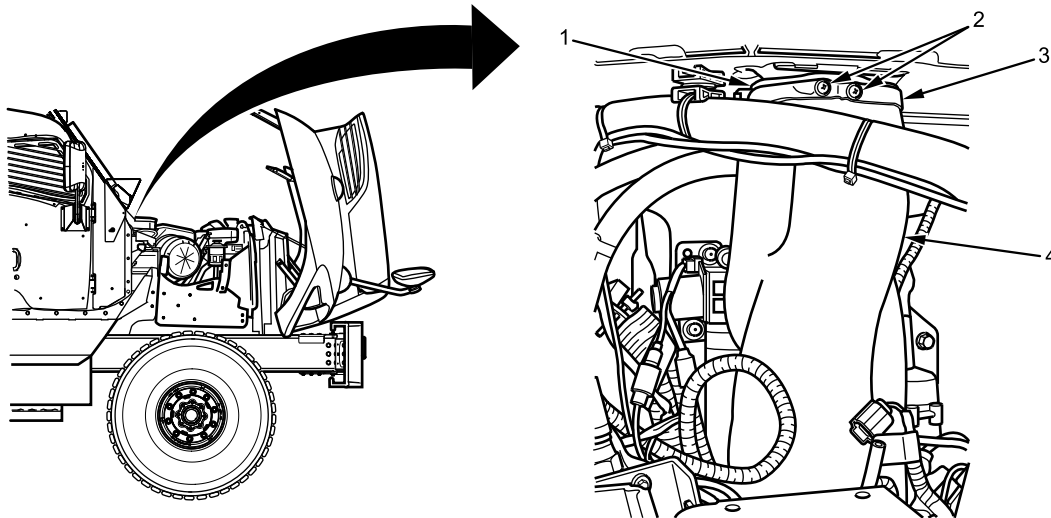

P231801221

Figure 1. Cowl Panel Drain Tube.

2. Remove cowl drain tube (Figure 1, Item 4) from cowl panel (Figure 1, Item 1).

END OF TASK**INSTALLATION**

1. Install cowl drain tube (Figure 1, Item 4) under cowl panel (Figure 1, Item 1).
2. Install metal band (Figure 1, Item 3) with screws and washers (Figure 1, Item 2) on cowl drain tube (Figure 1, Item 4). Tighten screws securely.
3. Tighten metal band (Figure 1, Item 3) on cowl panel (Figure 1, Item 1).

END OF TASK**FOLLOW-ON MAINTENANCE**

1. Close hood (TM 9-2355-106-10).
2. Remove wheel chocks (TM 9-2355-106-10).

END OF TASK**END OF WORK PACKAGE**

FIELD MAINTENANCE

MOTOR BAFFLE REMOVAL AND INSTALLATION

INITIAL SETUP:**Tools and Special Tools**

General Mechanic's Tool Kit (GMTK)
(WP 0795, Item 37)

TM 9-2355-106-23P

WP 0786

WP 0782

Materials/Parts

Face shield, industrial (WP 0794, Item 16)
Goggles, industrial (WP 0794, Item 20)
Compound (WP 0794, Item 13)
Gloves (WP 0794, Item 18)
Compound, sealing (WP 0794, Item 2)

Equipment Condition

Parking brake set (TM 9-2355-106-10)
Transmission set in NEUTRAL (N) (TM 9-2355-106-10)
Engine off (TM 9-2355-106-10)
MAIN POWER switch off (TM 9-2355-106-10)
Wheels chocked (TM 9-2355-106-10)
Engine hood open and secured (TM 9-2355-106-10)
Driver control mounting bracket assembly exterior armor removed (WP 0646)
Cowl panel drain tube removed (WP 0650)

Personnel Required

Maintainer - (2)

References

TM 9-2355-106-10

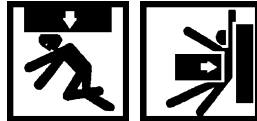
WARNING

Engine hood is extremely heavy and requires two-person lift. Ensure that there is adequate space in front of the vehicle to open hood completely without pinning or pinching personnel between hood and any other structure. Use extreme care when working under hood and make sure it is properly supported. Failure to comply may result in serious injury or death to personnel.

MOTOR BAFFLE REMOVAL AND INSTALLATION - (CONTINUED)**REMOVAL****NOTE**

Motor baffle is bonded to cowl with adhesive sealant. Use a thin tool to break bond while carefully working motor baffle away from cowl.

1. With assistant, remove six bolts (Figure 1, Item 4) and motor baffle (Figure 1, Item 3) from cowl (Figure 1, Item 1).

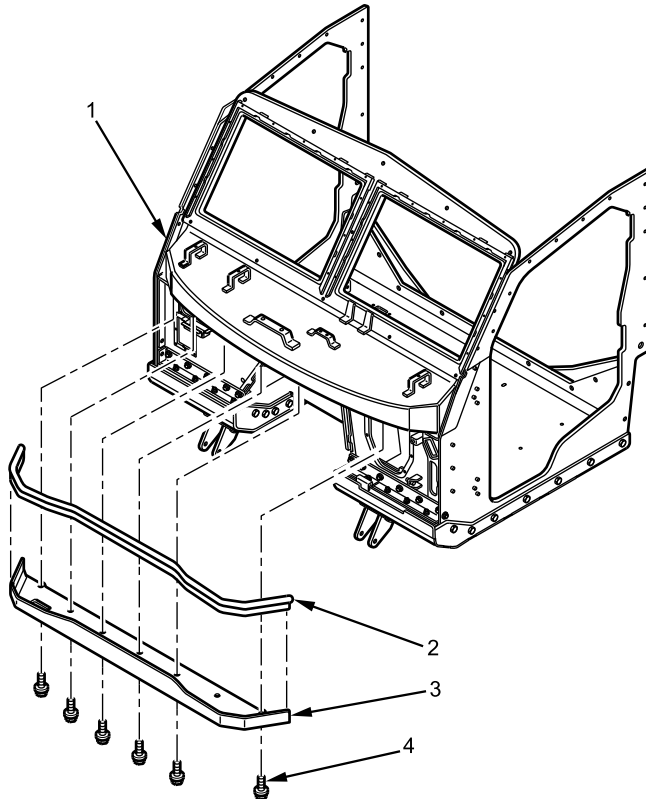

B231803654

Figure 1. Motor Baffle and Flat Back Cowl Seal.

2. Pull flat back cowl seal (Figure 1, Item 2) from leading edge of motor baffle (Figure 1, Item 3) .

END OF TASK

MOTOR BAFFLE REMOVAL AND INSTALLATION - (CONTINUED)**CLEANING**

1. Clean adhesive from motor baffle and from cowl.

END OF TASK**INSTALLATION****WARNING**

Corrosion preventive compound is toxic. Use only in well-ventilated area. Do not get in eyes; wear chemical safety goggles and full-face shield when using. Avoid contact with skin and wear rubber or plastic, solvent-resistant gloves. In case of contact, remove contaminated clothing and immediately wash area with soap and water. If compound contacts eyes, flush eyes with large amounts of water for at least 15 minutes and get immediate medical attention. If swallowed, do not induce vomiting; contact a physician immediately. Failure to comply may result in serious injury or death to personnel.

Sealing compound is toxic. Use only in well-ventilated area. Do not get in eyes; wear chemical safety goggles and full-face shield when using. Avoid contact with skin and wear rubber or plastic, solvent-resistant gloves. In case of contact, remove contaminated clothing and immediately wash area with soap and water. If compound contacts eyes, flush eyes with large amounts of water for at least 15 minutes and get immediate medical attention. If swallowed, do not induce vomiting; contact a physician immediately. Failure to comply may result in serious injury or death to personnel.

1. Apply corrosion preventive compound on all motor baffle bolt threads.

MOTOR BAFFLE REMOVAL AND INSTALLATION - (CONTINUED)

2. Position flat back cowl seal (Figure 2, Item 2) on leading edge of motor baffle (Figure 2, Item 3). Push down to seat.

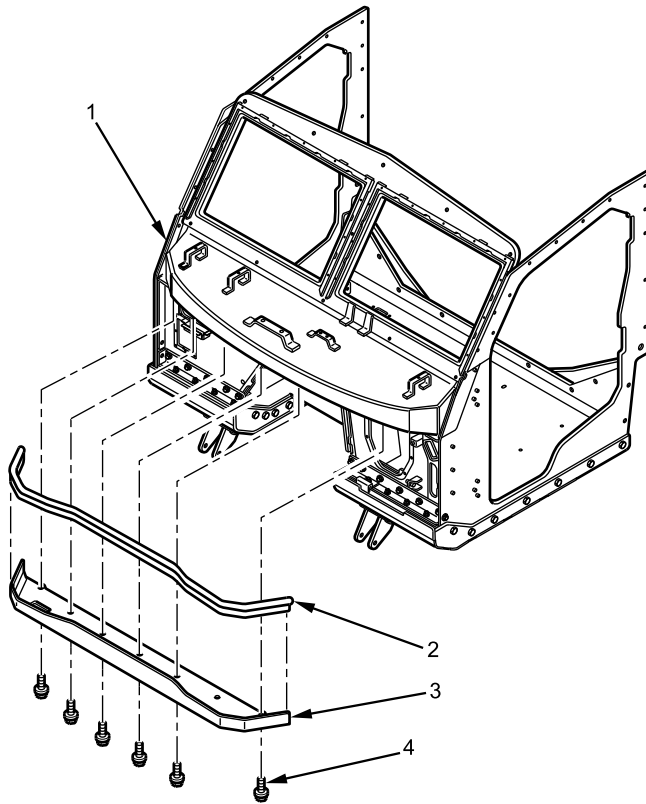

B231803654

Figure 2. Motor Baffle and Flat Back Cowl Seal.

3. Apply 1/4-in. bead of sealing compound to motor baffle mating surface.
4. With assistant, install motor baffle (Figure 2, Item 3) on cowl (Figure 2, Item 1) with six bolts (Figure , Item 4). Tighten bolts securely.

END OF TASK**FOLLOW-ON MAINTENANCE**

1. Install driver control mounting bracket assembly exterior armor (WP 0646).
2. Install cowl panel drain tube (WP 0650).
3. Close and secure engine hood (TM 9-2355-106-10).
4. Remove wheel chocks (TM 9-2355-106-10).

END OF TASK**END OF WORK PACKAGE**

FIELD MAINTENANCE**REAR WINDOW ARMOR GLASS REMOVAL AND INSTALLATION**

INITIAL SETUP:**Tools and Special Tools**

General Mechanic's Tool Kit (GMTK)
(WP 0795, Item 37)

TM 9-2355-106-23P

WP 0786

WP 0782

Materials/Parts

Gloves (WP 0794, Item 18)
Goggles, industrial (WP 0794, Item 20)
Faceshield, industrial (WP 0794, Item 16)
Dispenser, sealant (WP 0794, Item 14)
Compound (WP 0794, Item 13)
Adhesive (WP 0794, Item 2)
Self-sealing weatherstrip (WP 0794, Item 55)

Equipment Condition

Parking brake set (TM 9-2355-106-10)
Transmission set in NEUTRAL (N) (TM
9-2355-106-10)
Engine off (TM 9-2355-106-10)
MAIN POWER switch off (TM 9-2355-106-10)
Wheels chocked (TM 9-2355-106-10)
Body armor rear wall, riot guard, and bracket
removed (WP 0637)

ReferencesTM 9-2355-106-10

NOTE

This procedure is the same for right and left side rear windows. Left side shown.

REAR WINDOW ARMOR GLASS REMOVAL AND INSTALLATION - (CONTINUED)**REMOVAL****NOTE**

Use putty knife around edges of window to break window sealant loose.

1. Loosen 10 mounting bolts (Figure 1, Item 3) and break sealant that secures cabin window (Figure 1, Item 1) to mounting frame (Figure 1, Item 2).

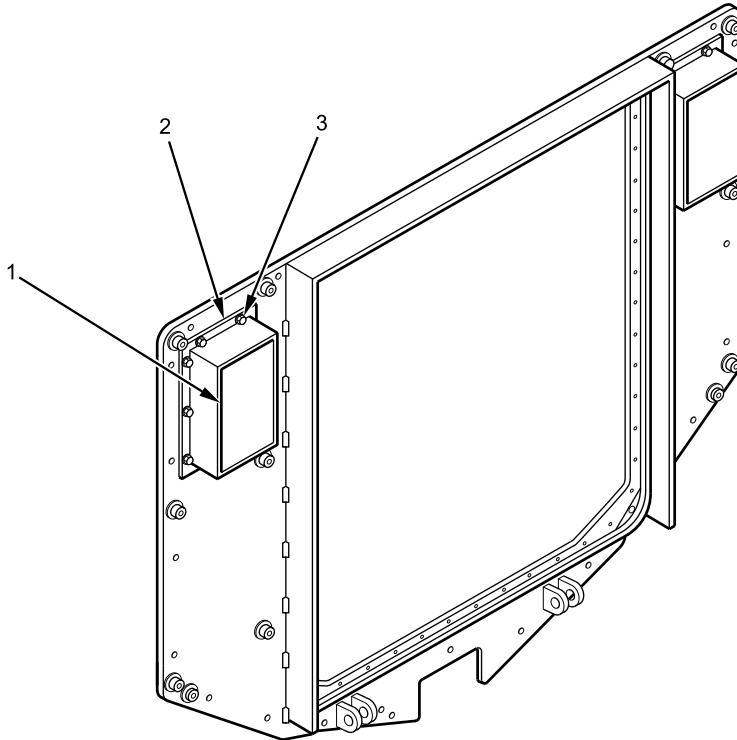

B231802595

Figure 1. Rear Window.

2. Remove 10 window mounting bolts (Figure 1, Item 3) and remove cabin window.
3. Remove old sealant and self-sealing weatherstrip from window mounting frame (Figure 1, Item 2).

END OF TASK

REAR WINDOW ARMOR GLASS REMOVAL AND INSTALLATION - (CONTINUED)**INSTALLATION****WARNING**

Corrosion preventive compound is toxic. Use only in well-ventilated area. Do not get in eyes; wear chemical safety goggles and full-face shield when using. Avoid contact with skin and wear rubber or plastic, solvent-resistant gloves. In case of contact, remove contaminated clothing and immediately wash area with soap and water. If compound contacts eyes, flush eyes with large amounts of water for at least 15 minutes and get immediate medical attention. If swallowed, do not induce vomiting; contact a physician immediately. Failure to comply may result in serious injury or death to personnel.

Adhesives, solvents, and sealing compounds can burn easily, can give off harmful vapors, and are harmful to skin and clothing. Wear goggles and protective clothing. Keep away from open flame and use in well-ventilated area. If adhesive, solvent, or sealing compound get on skin or clothing, wash immediately with soap and water. Failure to comply may result in injury or death to personnel.

1. Apply corrosion preventive compound on 10 rear window mounting bolts (Figure 1, Item 3).
2. Attach self-sealing weatherstrip to window mounting frame (Figure 1, Item 2).
3. Apply 1/4-in. bead of adhesive around window mounting frame (Figure 1, Item 2).
4. Guide window (Figure 1, Item 1) into position and install 10 mounting bolts (Figure 1, Item 3) loosely. Tighten mounting bolts securely after all bolts are installed.

END OF TASK**FOLLOW-ON MAINTENANCE**

1. Install body armor rear wall, riot guard, and bracket (WP 0637).
2. Remove wheel chocks (TM 9-2355-106-10).

END OF TASK**END OF WORK PACKAGE**

FIELD MAINTENANCE**DOOR WINDOW ARMOR GLASS REMOVAL AND INSTALLATION**

INITIAL SETUP:**Tools and Special Tools**

General Mechanic's Tool Kit (GMTK)
(WP 0795, Item 37)
Lifting device (WP 0795, Item 67)
Lifting sling (WP 0795, Item 68)

Materials/Parts

Gloves (WP 0794, Item 18)
Goggles, industrial (WP 0794, Item 20)
Faceshield, industrial (WP 0794, Item 16)
Compound (WP 0794, Item 13)
Adhesive (WP 0794, Item 2)
Self-sealing weatherstrip (WP 0794, Item 55)

Personnel Required

Maintainer - (3)

References

TM 9-2355-106-10
TM 9-2355-106-23P
WP 0786
WP 0782

Equipment Condition

Parking brake set (TM 9-2355-106-10)
Transmission set in NEUTRAL (N) (TM
9-2355-106-10)
Engine off (TM 9-2355-106-10)
MAIN POWER switch off (TM 9-2355-106-10)
Wheels chocked (TM 9-2355-106-10)
Door armor panel removed (WP 0609)

WARNING

Cabin windows are heavy. Use two assistants to ensure window remains securely attached to sling. Failure to comply may result in equipment damage and serious injury or death to personnel.

DOOR WINDOW ARMOR GLASS REMOVAL AND INSTALLATION - (CONTINUED)**NOTE**

This procedure is the same for right and left side door windows. Left side shown.

REMOVAL

1. Secure lifting sling to door window (Figure 1, Item 2) and attach sling to lifting device.

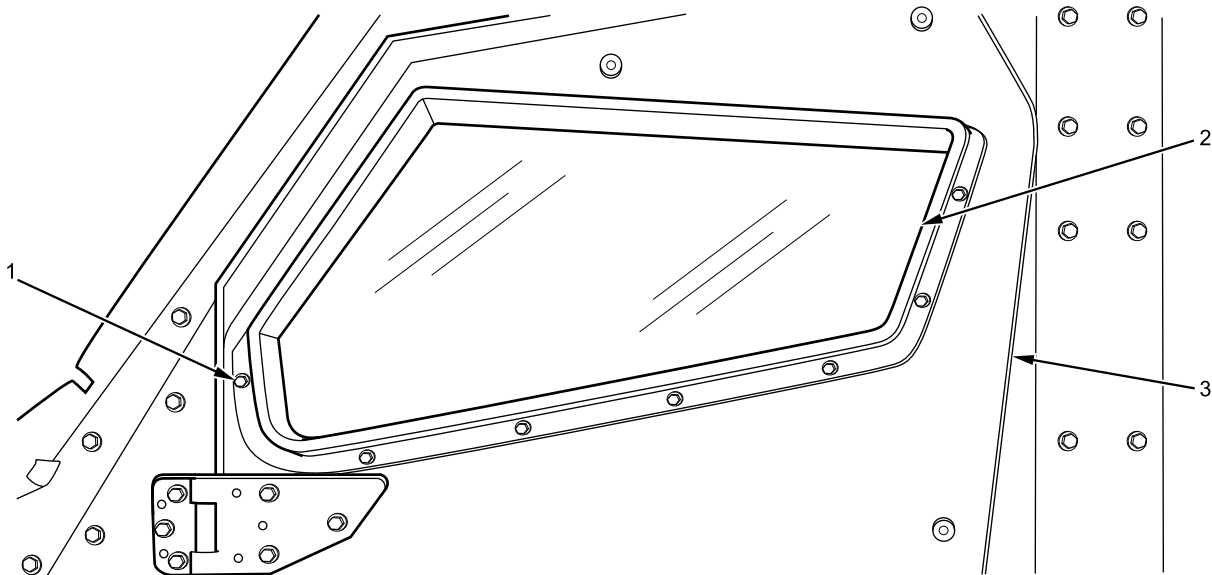

B231802563

Figure 1. Door Window.

NOTE

Use putty knife around edges of window to break window sealant loose.

2. Loosen 14 mounting bolts (Figure 1, Item 1) and break sealant loose that secures window (Figure 1, Item 2) to door (Figure 1, Item 3).
3. With window (Figure 1, Item 2) secured in lifting sling, work window from seated position.
4. When window (Figure 1, Item 2) is loose and supported by sling, remove 14 window mounting bolts (Figure 1, Item 1). With assistants, remove cabin window.
5. Remove old sealant and self-sealing weatherstrip from window frame.

END OF TASK

DOOR WINDOW ARMOR GLASS REMOVAL AND INSTALLATION - (CONTINUED)

INSTALLATION

WARNING



Corrosion preventive compound is toxic. Use only in well-ventilated area. Do not get in eyes; wear chemical safety goggles and full-face shield when using. Avoid contact with skin and wear rubber or plastic, solvent-resistant gloves. In case of contact, remove contaminated clothing and immediately wash area with soap and water. If compound contacts eyes, flush eyes with large amounts of water for at least 15 minutes and get immediate medical attention. If swallowed, do not induce vomiting; contact a physician immediately. Failure to comply may result in serious injury or death to personnel.

1. Apply corrosion preventive compound on 14 window mounting bolts (Figure 2, Item 1).

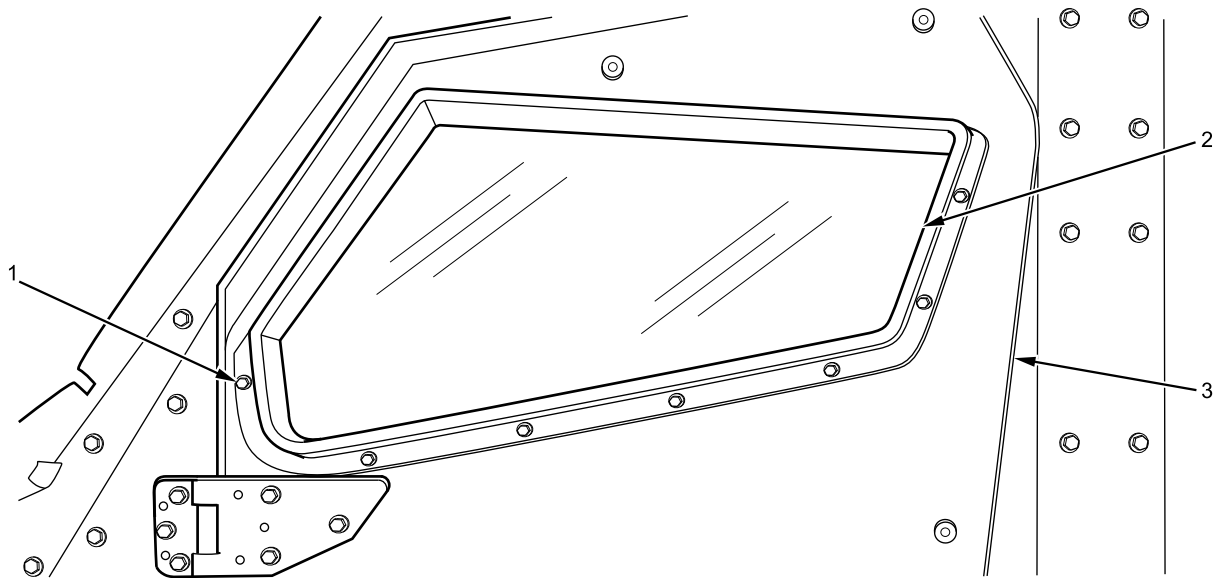

B231802563

Figure 2. Door Window.

2. Attach self-sealing weatherstrip to vehicle window frame.
3. Apply 1/4-in. bead of adhesive around window mounting frame (Figure 2, Item 2).
4. With assistants, guide window (Figure 2, Item 2) into position and loosely install 14 mounting bolts (Figure 2, Item 1). Tighten mounting bolts securely.
5. Remove lifting sling.

END OF TASK

DOOR WINDOW ARMOR GLASS REMOVAL AND INSTALLATION - (CONTINUED)**FOLLOW-ON MAINTENANCE**

1. Install door armor panel (WP 0609).
2. Remove wheel chocks (TM 9-2355-106-10).

END OF TASK**END OF WORK PACKAGE**

FIELD MAINTENANCE

CABIN WINDOW ARMOR GLASS REMOVAL AND INSTALLATION

INITIAL SETUP:

Tools and Special Tools

General Mechanic's Tool Kit (GMTK)
(WP 0795, Item 37)
Lifting device (WP 0795, Item 67)
Lifting sling (WP 0795, Item 68)
Scraper, gasket (WP 0795, Item 87)

TM 9-2355-106-23P

WP 0786

WP 0782

Materials/Parts

Gloves (WP 0794, Item 18)
Goggles, industrial (WP 0794, Item 20)
Faceshield, industrial (WP 0794, Item 16)
Adhesive (WP 0794, Item 2)
Self-sealing weatherstrip (WP 0794, Item 55)
Corrosive preventive compound WP 0794, Item 13

Equipment Condition

Parking brake set (TM 9-2355-106-10)
Transmission set in NEUTRAL (N) (TM
9-2355-106-10)
Engine off (TM 9-2355-106-10)
MAIN POWER switch off (TM 9-2355-106-10)
Wheels chocked (TM 9-2355-106-10)
Exterior body armor left front panel removed
(WP 0633)
Exterior body armor left middle front panel removed
(WP 0634)
Exterior body armor middle rear panel removed
(WP 0630)
Exterior body armor rear panel removed (WP 0631)

Personnel Required

Maintainer - (3)

References

TM 9-2355-106-10

REMOVAL

WARNING



Cabin windows are heavy. Use two assistants to ensure window remains securely attached to sling. Failure to comply may result in equipment damage and serious injury or death to personnel.

NOTE

This procedure is the same for right and left side cabin windows. Left side shown.

CABIN WINDOW ARMOR GLASS REMOVAL AND INSTALLATION - (CONTINUED)

1. Secure lifting sling (Figure 1, Item 2) to cabin window (Figure 1, Item 3) and attach sling to lifting device.

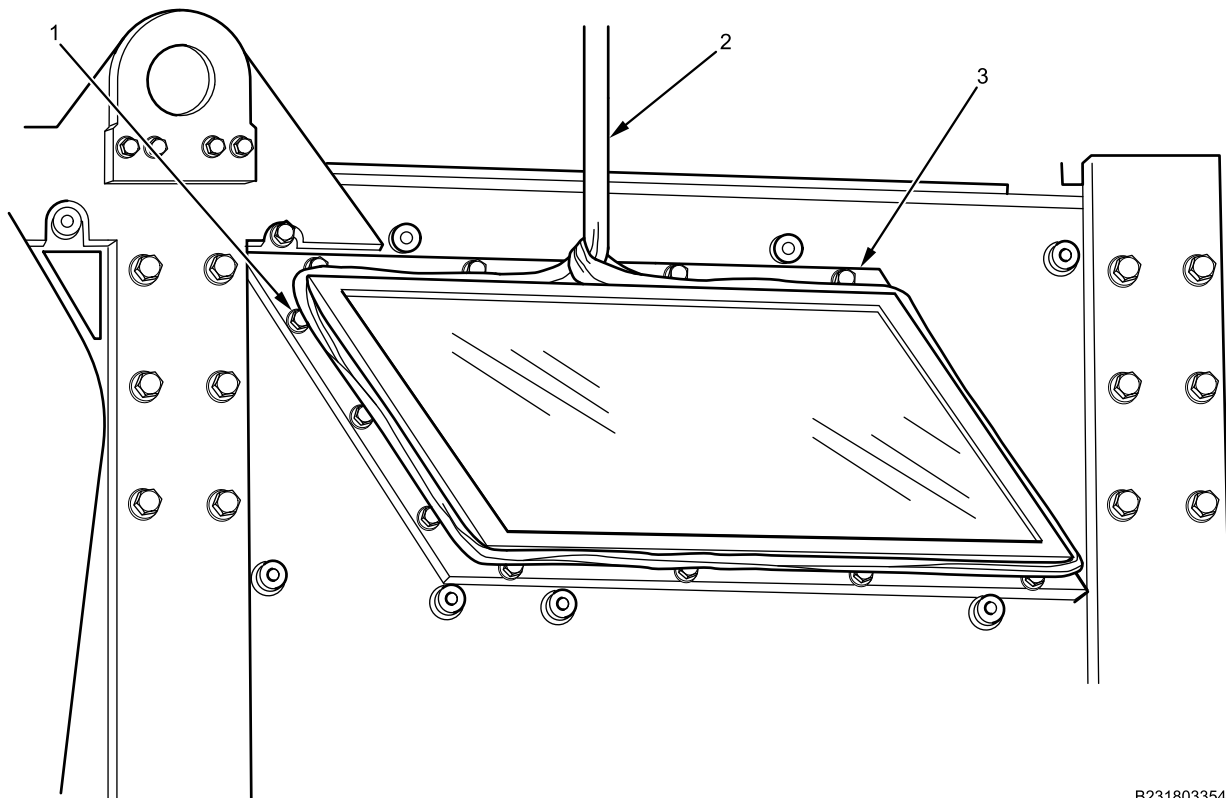

B231803354

Figure 1. Cabin Window.

2. Remove four bolts (Figure 1, Item 1) along bottom of window.
3. Remove three bolts (Figure 1, Item 1) along front of window and three bolts (Figure 1, Item 1) along rear of window. Three bolts along rear of window not shown.

NOTE

Use gasket scraper around edges of window to break window sealant loose.

4. Loosen four bolts (Figure 1, Item 1) along top of window and break sealant that secures cabin window (Figure 1, Item 3) to vehicle.
5. With assistants, keep window secure in sling and remove four window mounting bolts (Figure 1, Item 1). Remove cabin window from vehicle.
6. With gasket scraper, remove old sealant and Self-sealing weatherstrip from window frame and window mounting area on vehicle.

END OF TASK

CABIN WINDOW ARMOR GLASS REMOVAL AND INSTALLATION - (CONTINUED)**INSTALLATION****WARNING**

Corrosion preventive compound is toxic. Use only in well-ventilated area. Do not get in eyes; wear chemical safety goggles and full-face shield when using. Avoid contact with skin and wear rubber or plastic, solvent-resistant gloves. In case of contact, remove contaminated clothing and immediately wash area with soap and water. If compound contacts eyes, flush eyes with large amounts of water for at least 15 minutes and get immediate medical attention. If swallowed, do not induce vomiting; contact a physician immediately. Failure to comply may result in serious injury or death to personnel.

1. Apply corrosion preventive compound on 14 cabin window mounting bolts (Figure 1, Item 1).
2. Attach self-sealing weatherstrip to vehicle window mounting frame.
3. Apply 1/4-in. bead of adhesive around window mounting frame.

WARNING

Cabin windows are heavy. Use two assistants to ensure window remains securely attached to sling. Failure to comply may result in equipment damage and serious injury or death to personnel.

4. With assistants, secure window (Figure 1, Item 3) in lifting sling (Figure 1, Item 2) and attach sling to lifting device.
5. With assistants, keep window secure in lifting sling (Figure 1, Item 2) and guide window (Figure 1, Item 2) into position on vehicle.
6. Install 14 mounting bolts (Figure 1, Item 1) loosely. Tighten mounting bolts securely.
7. Remove lifting sling (Figure 1, Item 2) from window (Figure 1, Item 3).

END OF TASK

CABIN WINDOW ARMOR GLASS REMOVAL AND INSTALLATION - (CONTINUED)**FOLLOW-ON MAINTENANCE**

1. Install exterior body armor rear panel (WP 0631).
2. Install exterior body armor middle rear panel (WP 0630).
3. Install exterior body armor left middle front panel (WP 0634).
4. Install exterior body armor left front panel (WP 0633).
5. Remove wheel chocks (TM 9-2355-106-10).

END OF TASK**END OF WORK PACKAGE**

FIELD MAINTENANCE

WINDSHIELD ARMOR GLASS REMOVAL AND INSTALLATION

INITIAL SETUP:

Tools and Special Tools

General Mechanic's Tool Kit (GMTK)
(WP 0795, Item 37)
Lifting device (WP 0795, Item 67)
Lifting sling (WP 0795, Item 68)

TM 9-2355-106-23P

WP 0786

WP 0782

Materials/Parts

Compound (WP 0794, Item 13)
Gloves (WP 0794, Item 18)
Cable lock straps - (2) (WP 0796, Item 124)
Adhesive (WP 0794, Item 2)
Dispenser, sealant (WP 0794, Item 14)
Self-sealing weatherstrip (WP 0794, Item 55)
Goggles, industrial (WP 0794, Item 20)
Faceshield, industrial (WP 0794, Item 16)

Equipment Condition

Parking brake set (TM 9-2355-106-10)
Transmission set in NEUTRAL (N) (TM 9-2355-106-10)
Engine off (TM 9-2355-106-10)
MAIN POWER switch off (TM 9-2355-106-10)
Wheels chocked (TM 9-2355-106-10)
Front clearance light removed (WP 0369)
Wiper cowl panel removed (WP 0683)
Windshield wiper motor, transmission, bracket, and linkage assembly removed (WP 0684)
Windshield washer hose assembly removed (WP 0687)
Windshield armor removed (WP 0645)

Personnel Required

Maintainer (2)

References

TM 9-2355-106-10

NOTE

This procedure is the same for right and left windshield. Left side windshield covered in this procedure.

REMOVAL

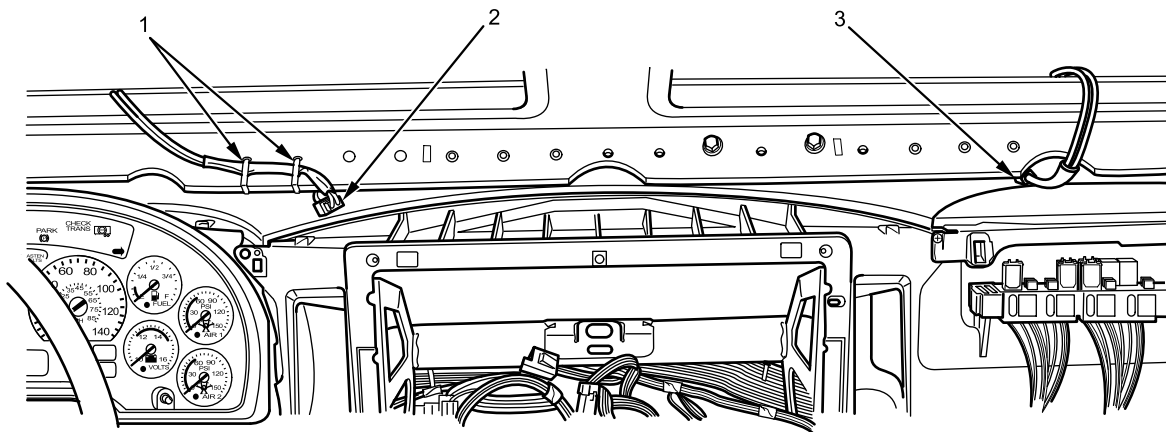

B231801344

Figure 1. Heated Windshield Electrical Connectors.

1. Disconnect left side heated windshield electrical connector (Figure 1, Item 2) from inside vehicle.
2. Disconnect right side heated windshield electrical connector (Figure 1, Item 3).
3. Remove and discard cable lock straps (Figure 1, Item 1) securing heated windshield electrical harness to vehicle.

WINDSHIELD ARMOR GLASS REMOVAL AND INSTALLATION - (CONTINUED)

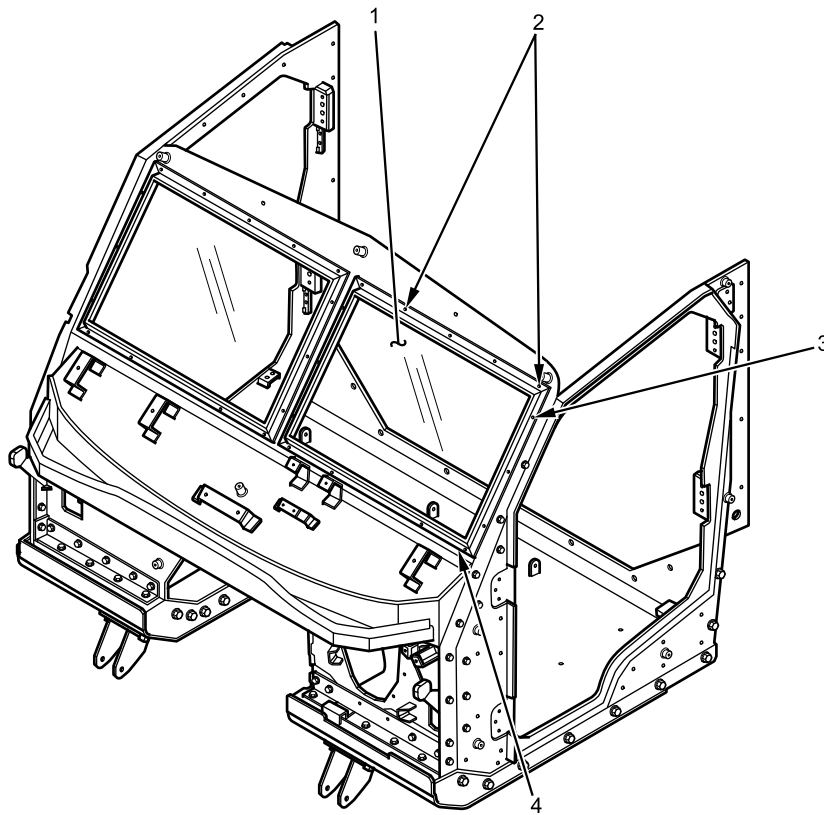

B231810562

Figure 2. Windshield.

4. Loosen two upper mounting bolts (Figure 2, Item 2).
5. Remove remaining 13 windshield mounting bolts (Figure 2, Item 3) from windshield (Figure 2, Item 1).
6. Remove sealant securing windshield mounting frame (Figure 2, Item 4) to body.

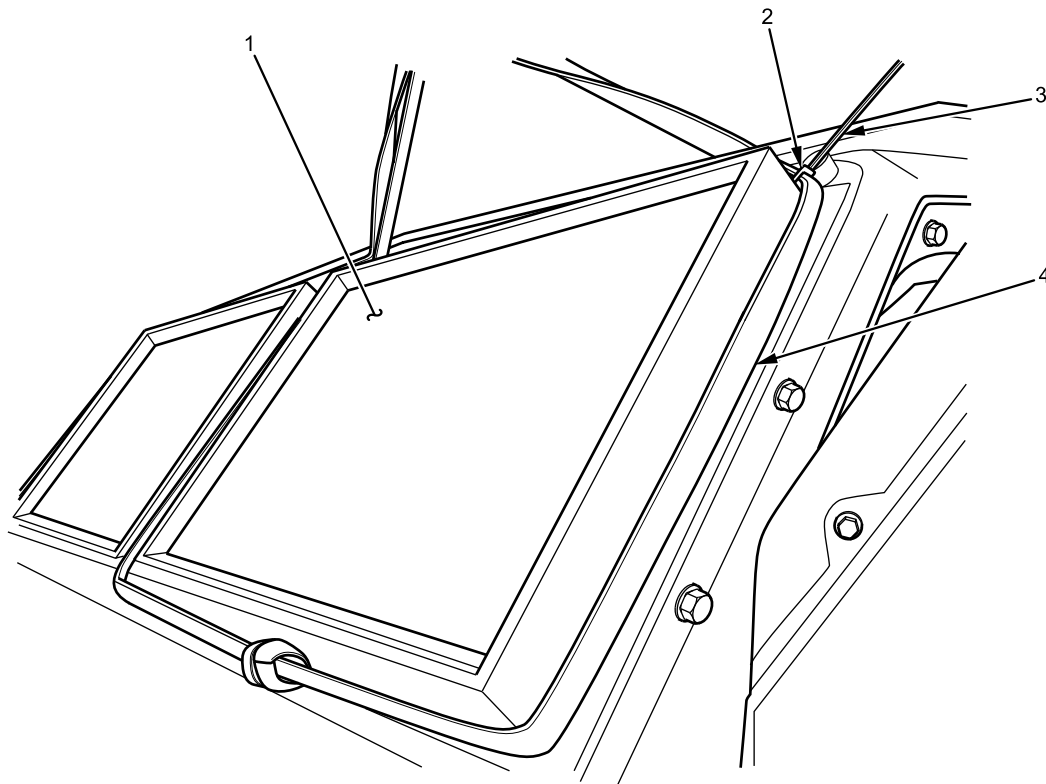
WINDSHIELD ARMOR GLASS REMOVAL AND INSTALLATION - (CONTINUED)

B231803439

Figure 3. Windshield Removal With Sling.

7. Attach sling (Figure 3, Item 4) to windshield (Figure 3, Item 1).
8. Remove two remaining upper windshield bolts (Figure 2, Item 2).
9. With assistant pushing out on inside windshield, use a crowbar on outboard upper corner, working across the top, then down the side to break the windshield seal.
10. Install two cable lock straps (Figure 3, Item 3) to windshield frame upper corner mounting holes and sling (Figure 3, Item 2).
11. With assistant, remove windshield.

END OF TASK**CLEANING**

1. Remove old sealant and self-sealing weatherstrip from mounting frame and vehicle. Discard old self-sealing weatherstrip.
2. Wipe area around mounting frame and window opening on vehicle to remove debris.

END OF TASK

WINDSHIELD ARMOR GLASS REMOVAL AND INSTALLATION - (CONTINUED)**INSTALLATION****WARNING**

Corrosion preventive compound is toxic. Use only in well-ventilated area. Do not get in eyes; wear chemical safety goggles and full-face shield when using. Avoid contact with skin and wear rubber or plastic, solvent-resistant gloves. In case of contact, remove contaminated clothing and immediately wash area with soap and water. If compound contacts eyes, flush eyes with large amounts of water for at least 15 minutes and get immediate medical attention. If swallowed, do not induce vomiting; contact a physician immediately. Failure to comply may result in serious injury or death to personnel.

Adhesives, solvents, and sealing compounds can burn easily, can give off harmful vapors, and are harmful to skin and clothing. Wear goggles and protective clothing. Keep away from open flame and use in well-ventilated area. If adhesive, solvent, or sealing compound get on skin or clothing, wash immediately with soap and water. Failure to comply may result in injury or death to personnel.

1. Apply corrosion preventive compound on 15 windshield mounting bolts (Figure 4, Item 2 and 3).

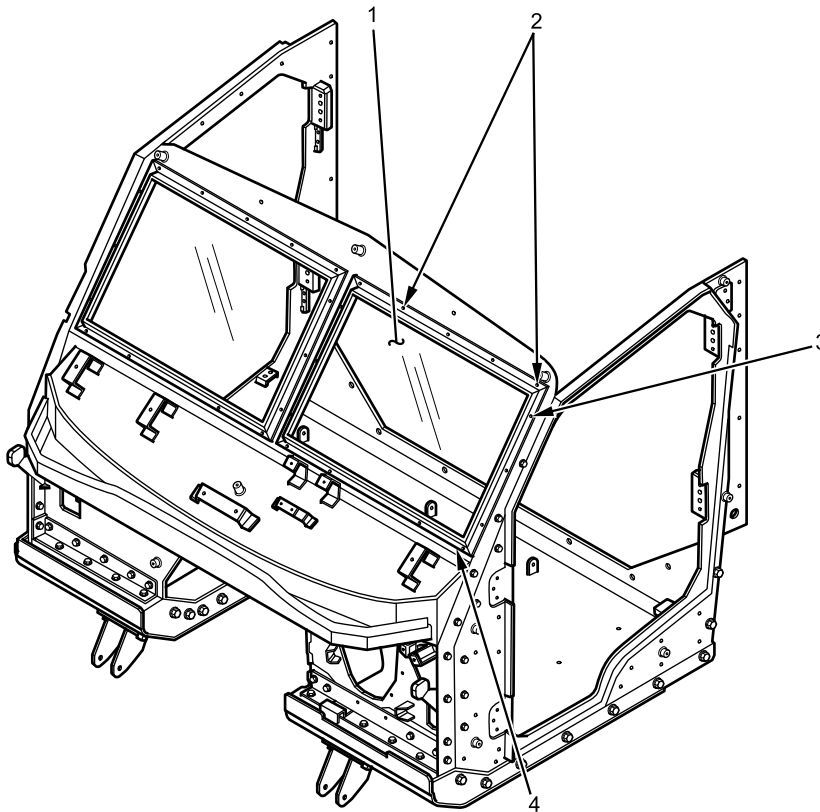

B231810562

Figure 4. Windshield.

2. Attach self-sealing weatherstrip to vehicle mounting frame (Figure 4, Item 4).

WINDSHIELD ARMOR GLASS REMOVAL AND INSTALLATION - (CONTINUED)

3. Apply 1/4-in. bead of sealant around mounting frame (Figure 4, Item 4).
4. With assistant and lifting sling, guide windshield (Figure 4, Item 1) into position and cut cable lock straps. Discard cable lock straps.
5. Install 15 mounting bolts (Figure 4, Item 2 and 3) loosely. Tighten mounting bolts securely after all bolts are installed.
6. Remove lifting sling.
7. Install left side heated windshield electrical connector (Figure 5, Item 2).

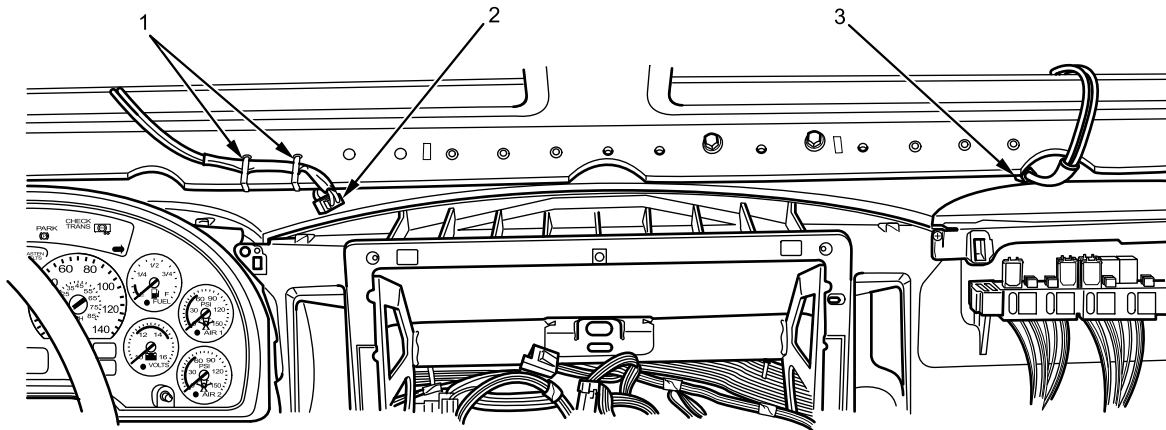

B231801344

Figure 5. Heated Windshield Electrical Connectors.

8. Install right side heated windshield electrical connector (Figure 5, Item 3).
9. Secure heated windshield electrical harness to vehicle with new cable lock straps (Figure 5, Item 1).

END OF TASK**FOLLOW-ON MAINTENANCE**

1. Install windshield armor (WP 0645).
2. Install windshield washer hose assembly (WP 0687).
3. Install windshield wiper motor, transmission, bracket, and linkage assembly (WP 0684).
4. Install cowl panel (WP 0683).
5. Install front clearance light (WP 0369).
6. Remove wheel chocks (TM 9-2355-106-10).

END OF TASK**END OF WORK PACKAGE**

FIELD MAINTENANCE

STEP AND BRACKETS REMOVAL AND INSTALLATION

INITIAL SETUP:

Tools and Special Tools

General Mechanic's Tool Kit (GMTK)
(WP 0795, Item 37)

TM 9-2355-106-23P

WP 0786

WP 0782

Materials/Parts

Compound (WP 0794, Item 13)
Goggles, industrial (WP 0794, Item 20)
Faceshield, industrial (WP 0794, Item 16)
Gloves (WP 0794, Item 18)

Equipment Condition

Parking brake set (TM 9-2355-106-10)
Transmission set in NEUTRAL (N) (TM
9-2355-106-10)
Engine off (TM 9-2355-106-10)
MAIN POWER switch off (TM 9-2355-106-10)
Wheels chocked (TM 9-2355-106-10)

References

TM 9-2355-106-10

NOTE

Right side shown; left side similar.

REMOVAL

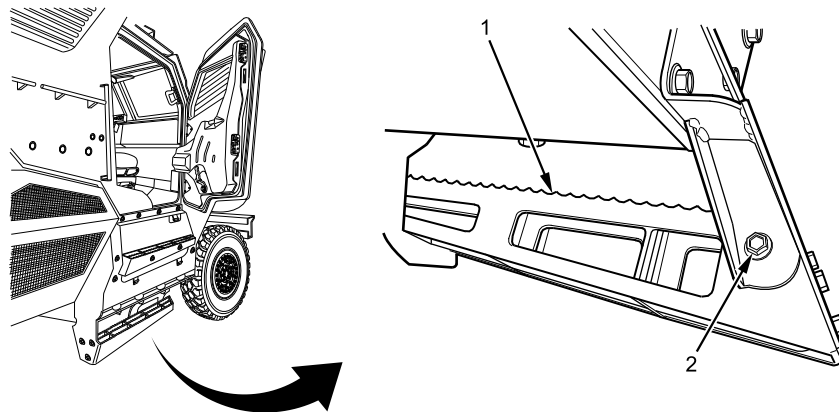

B231810856

Figure 1. Left Side Steps, Inside Bolt.

1. Remove bolt and washer (Figure 1, Item 2) from step (Figure 1, Item 1).

STEP AND BRACKETS REMOVAL AND INSTALLATION - (CONTINUED)

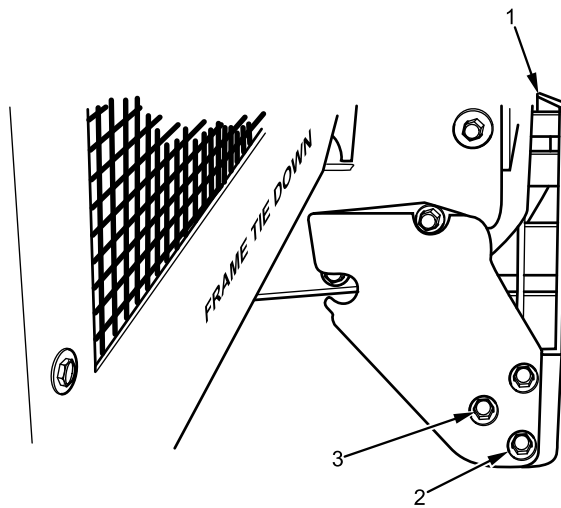

B231801637

Figure 2. Rear Bolts.

2. Remove three bolts (Figure 2, Item 3) and three washers (Figure 2, Item 2) from step (Figure 2, Item 1).

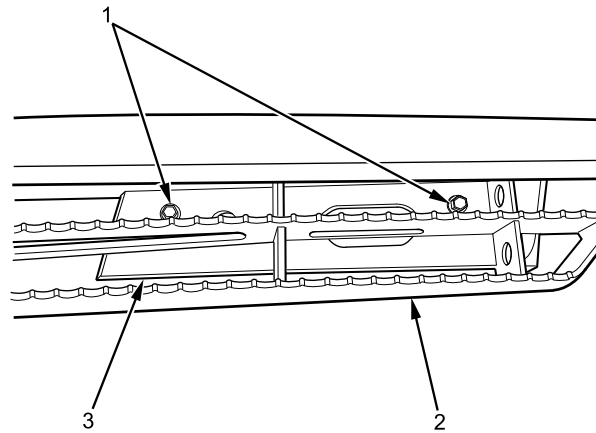

B231801639

Figure 3. Step.

3. Remove two nuts, two bolts (Figure 3, Item 1), and step (Figure 3, Item 2) from step bracket (Figure 3, Item 3).

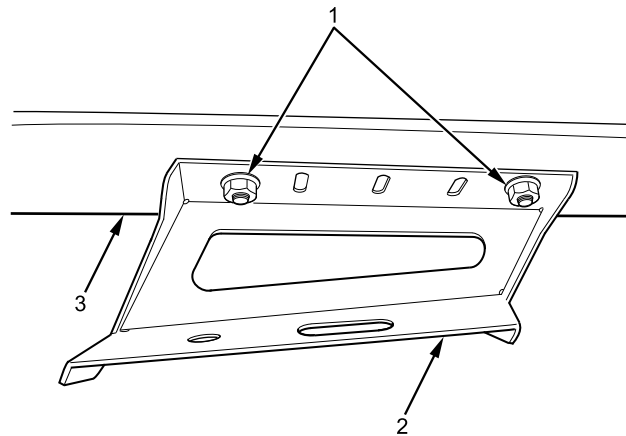
STEP AND BRACKETS REMOVAL AND INSTALLATION - (CONTINUED)

B231801640

Figure 4. Front Bracket.

4. Remove two nuts (Figure 4, Item 1) and front bracket (Figure 4, Item 2) from body armor (Figure 4, Item 3).

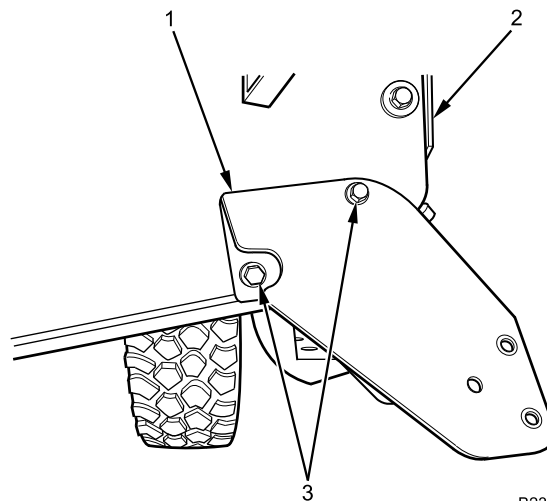

B231801641

Figure 5. Rear Bracket.

5. Remove two bolts (Figure 5, Item 3), washers, and rear bracket (Figure 5, Item 1) from body armor (Figure 5, Item 2).

END OF TASK

STEP AND BRACKETS REMOVAL AND INSTALLATION - (CONTINUED)

INSTALLATION

WARNING



Corrosion preventive compound is toxic. Use only in well-ventilated area. Do not get in eyes; wear chemical safety goggles and full-face shield when using. Avoid contact with skin and wear rubber or plastic, solvent-resistant gloves. In case of contact, remove contaminated clothing and immediately wash area with soap and water. If compound contacts eyes, flush eyes with large amounts of water for at least 15 minutes and get immediate medical attention. If swallowed, do not induce vomiting; contact a physician immediately. Failure to comply may result in serious injury or death to personnel.

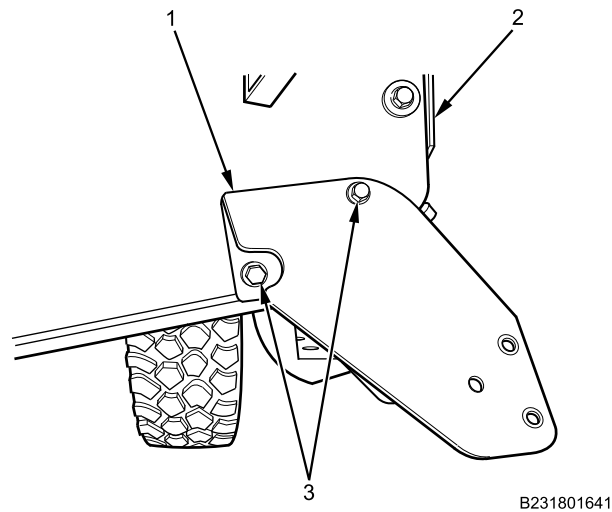
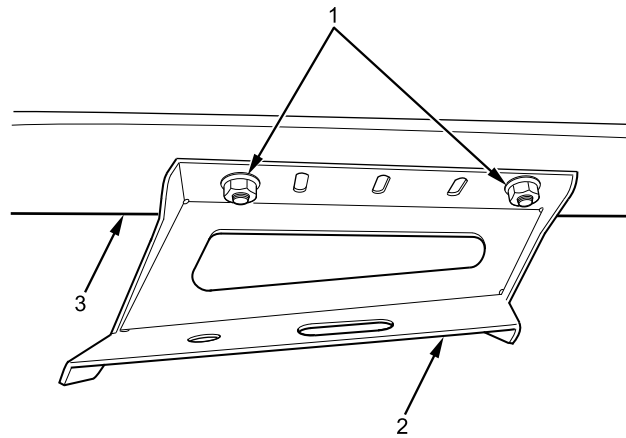

Figure 6. Rear Bracket.

1. Apply corrosion preventive compound on all step and bracket bolt threads.
2. Install rear bracket (Figure 6, Item 1) on body armor (Figure 6, Item 2) with two bolts (Figure 6, Item 3). Tighten and secure.

STEP AND BRACKETS REMOVAL AND INSTALLATION - (CONTINUED)

B231801640

Figure 7. Front Bracket.

3. Install front bracket (Figure 7, Item 2) on body armor (Figure 7, Item 3) with two nuts (Figure 7, Item 1). Tighten and secure.

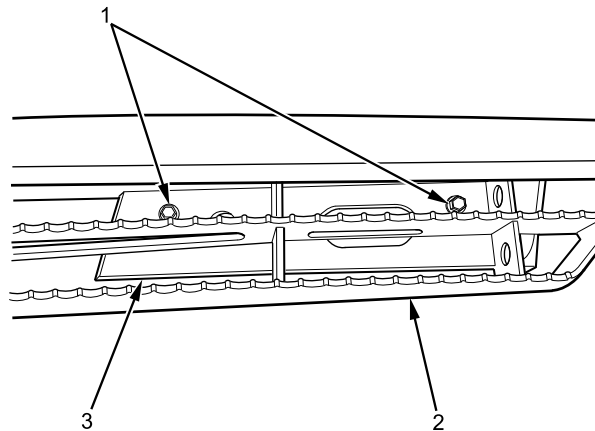

B231801639

Figure 8. Step.

4. Install step (Figure 8, Item 2) on step bracket (Figure 8, Item 3) with two bolts (Figure 8, Item 1) and two nuts. Do not tighten.

STEP AND BRACKETS REMOVAL AND INSTALLATION - (CONTINUED)

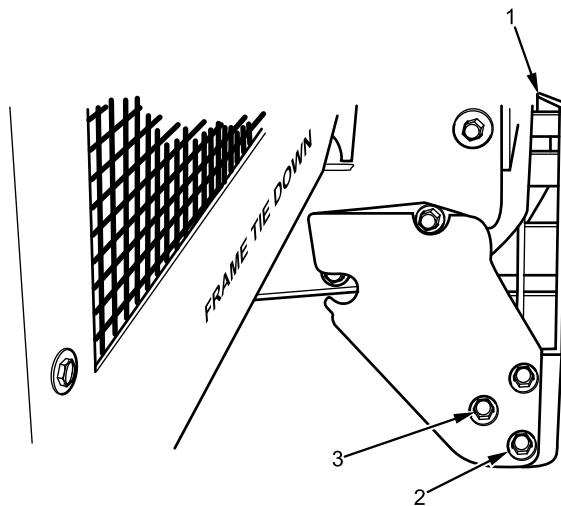

B231801637

Figure 9. Rear Bracket.

5. Install three washers (Figure 9, Item 2) and three bolts (Figure 9, Item 3) into step (Figure 9, Item 1). Do not tighten.

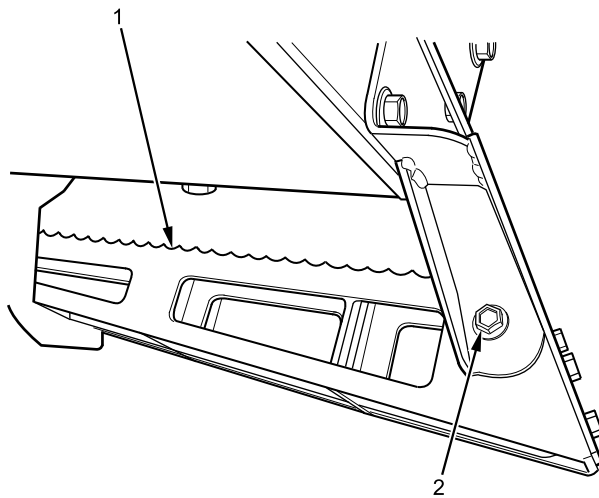

B231801638

Figure 10. Inside Bolt.

6. Install bolt (Figure 10, Item 2) into step (Figure 10, Item 1). Tighten and secure all step nuts and bolts.

END OF TASK**FOLLOW-ON MAINTENANCE**

1. Remove wheel chocks (TM 9-2355-106-10).

END OF TASK**END OF WORK PACKAGE**

FIELD MAINTENANCE
FENDER AND REINFORCEMENT REMOVAL AND INSTALLATION

INITIAL SETUP:**Tools and Special Tools**

General Mechanic's Tool Kit (GMTK)
(WP 0795, Item 37)
Blind rivet tool kit (WP 0795, Item 19)
Gloves, rubber (WP 0795, Item 38)

TM 9-2355-106-23P

WP 0786

WP 0782

Materials/Parts

Antiseize compound (WP 0794, Item 6)
Gloves (WP 0794, Item 18)
Goggles, industrial (WP 0794, Item 20)
Faceshield, industrial (WP 0794, Item 16)
Rivet (WP 0796, Item 156)

Equipment Condition

Parking brake set (TM 9-2355-106-10)

Transmission set in NEUTRAL (N) (TM 9-2355-106-10)

Engine off (TM 9-2355-106-10)

MAIN POWER switch off (TM 9-2355-106-10)

Wheels chocked (TM 9-2355-106-10)

Engine hood open and secured (TM 9-2355-106-10)

References

TM 9-2355-106-10

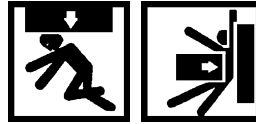
REMOVAL
WARNING

Engine hood is extremely heavy and requires two-person lift. Ensure that there is adequate space in front of the vehicle to open hood completely without pinning or pinching personnel between hood and any other structure. Use extreme care when working under hood and make sure it is properly supported. Failure to comply may result in serious injury or death to personnel.

NOTE

Left side shown; right side similar.

FENDER AND REINFORCEMENT REMOVAL AND INSTALLATION - (CONTINUED)

1. Remove rivet (Figure 1, Item 3) from fender (Figure 1, Item 1). Discard rivet.

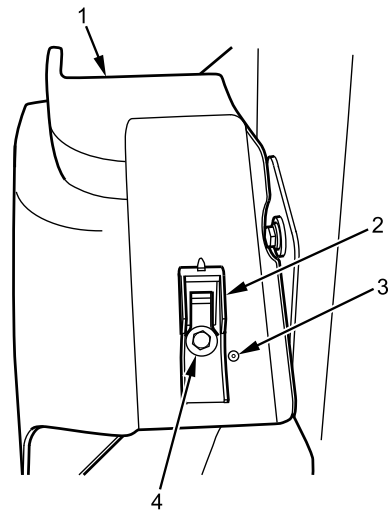

B231801470

Figure 1. Fender and Latch.

2. Remove bolt (Figure 1, Item 4) and latch (Figure 1, Item 2) from fender (Figure 1, Item 1).
3. Remove two bolts (Figure 2, Item 2) from fender (Figure 2, Item 1).

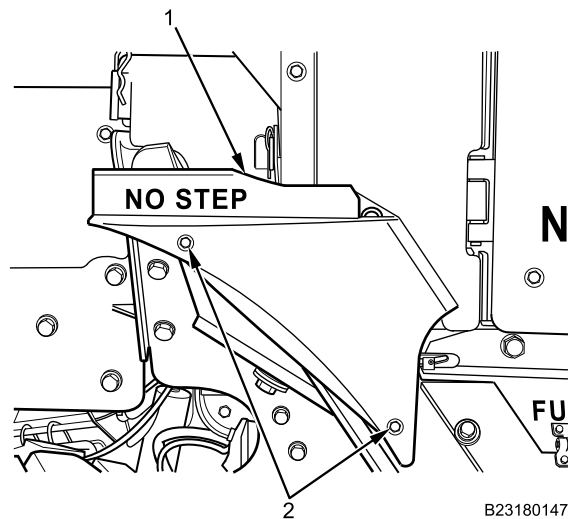

B231801471

Figure 2. Fender and Bolts.

4. Remove fender (Figure 2, Item 1) from vehicle.
5. Remove bolt (Figure 3, Item 4) from fender reinforcement (Figure 3, Item 1).

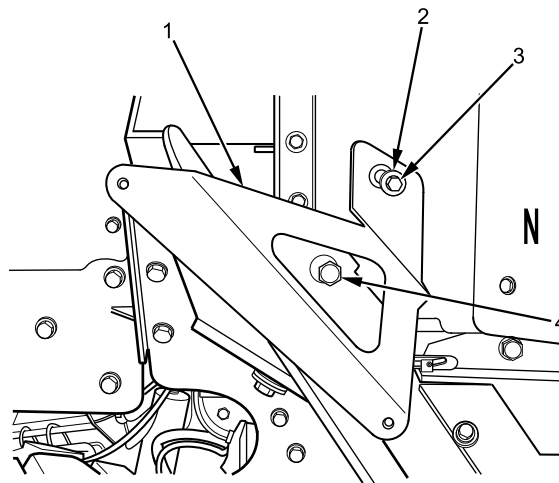
FENDER AND REINFORCEMENT REMOVAL AND INSTALLATION - (CONTINUED)

B231801472

Figure 3. Fender Reinforcement.

6. Remove bolt (Figure 3, Item 3) and washer (Figure 3, Item 2) from fender reinforcement (Figure 3, Item 1).
7. Remove fender reinforcement (Figure 3, Item 1) from vehicle.

END OF TASK

FENDER AND REINFORCEMENT REMOVAL AND INSTALLATION - (CONTINUED)

INSTALLATION

WARNING



Antiseize compound can cause skin, eye, and respiratory irritation. Inhalation can cause difficulty breathing, dizziness, headache, and nausea. Wear eye protection and use only with adequate ventilation. Do not use near heat, sparks, or open flame. Wash hands and eyes after using compound. In case of skin contact, wash affected area with soap and water, and seek medical attention if irritation persists. If compound contacts eyes, flush eyes with water for at least 15 minutes, and obtain medical attention if irritation persists. In case of accidental ingestion, do not induce vomiting. Slowly drink 1-2 glasses of water or milk, and seek medical attention. Store compound in a closed container away from heat. Dispose of it in accordance with standard operating procedures. Failure to comply may result in injury to personnel.

1. Apply antiseize compound on all fender reinforcement bolt threads (Figure 4, Item 3 and 4).

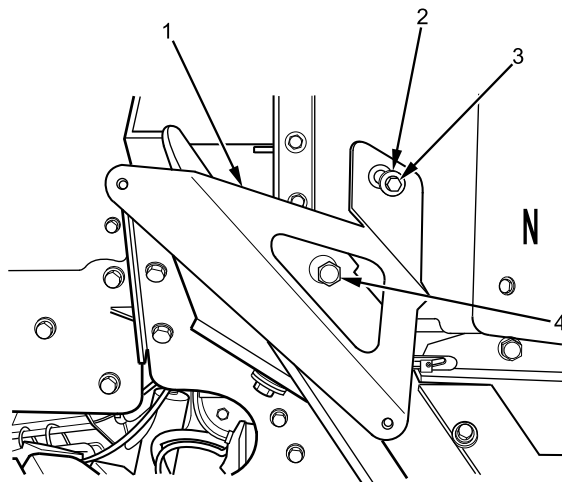

B231801472

Figure 4. Fender Reinforcement.

2. Install fender reinforcement (Figure 4, Item 1) on vehicle with bolt (Figure 4, Item 4). Do not tighten bolt.
3. Install washer (Figure 4, Item 2) and bolt (Figure 4, Item 3) into fender reinforcement (Figure 4, Item 1). Do not tighten bolt.
4. Install fender (Figure 5, Item 1) on vehicle with new rivet (Figure 5, Item 3).

FENDER AND REINFORCEMENT REMOVAL AND INSTALLATION - (CONTINUED)

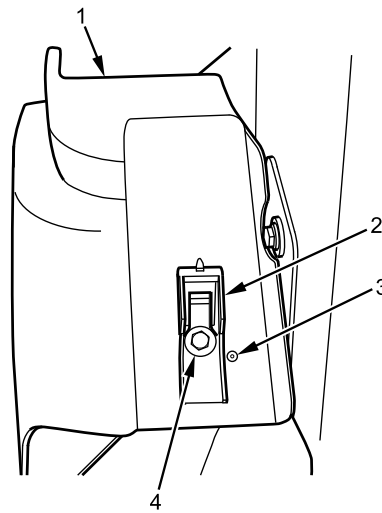

B231801470

Figure 5. Fender and Rivet.

5. Install fender latch (Figure 5, Item 2) on fender (Figure 5, Item 1) with bolt (Figure 5, Item 4). Tighten fender latch bolt securely.
6. Apply antiseize compound on fender bolt threads (Figure 6, Item 2).

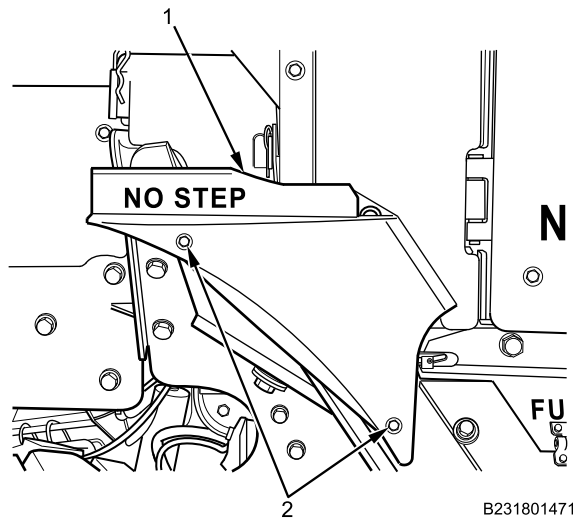

B231801471

Figure 6. Fender and Bolts

7. Install two bolts (Figure 6, Item 2) into fender (Figure 6, Item 1).
8. Align fender (Figure 6, Item 1) and reinforcement for proper fit and alignment to hood.
9. Tighten all fender and reinforcement bolts securely.

END OF TASK

FENDER AND REINFORCEMENT REMOVAL AND INSTALLATION - (CONTINUED)**FOLLOW-ON MAINTENANCE**

1. Close and secure engine hood (TM 9-2355-106-10).
2. Remove wheel chocks (TM 9-2355-106-10).

END OF TASK**END OF WORK PACKAGE**

FIELD MAINTENANCE**FLOOR PANEL (FRONT) REMOVAL AND INSTALLATION**

INITIAL SETUP:**Tools and Special Tools**

General Mechanic's Tool Kit (GMTK)
(WP 0795, Item 37)

Materials/Parts

Goggles, industrial (WP 0794, Item 20)
Faceshield, industrial (WP 0794, Item 16)
Compound (WP 0794, Item 13)
Gloves (WP 0794, Item 18)

Personnel Required

Maintainer (2)

References

TM 9-2355-106-10
TM 9-2355-106-23P
WP 0786
WP 0782

Equipment Condition

Parking brake set (TM 9-2355-106-10)
Transmission set in NEUTRAL (N) (TM 9-2355-106-10)
Engine off (TM 9-2355-106-10)
MAIN POWER switch off (TM 9-2355-106-10)
Wheels chocked (TM 9-2355-106-10)
Rear door/ramp lowered (TM 9-2355-106-10)
Gunner platform removed (WP 0668)
Communication rack removed (WP 0667)
Fire Suppression System (FSS) cabin dispersion cylinder removed (WP 0745)
Life Support System (LSS) box removed (WP 0761)
Driver seat removed (WP 0663)
Front passenger seat removed (WP 0666)
Front passenger seat floor bracket removed (WP 0665)

WARNING

Armor parts are heavy. Use care when removing or installing. Do not attempt to lift without an assistant. Wear gloves. Failure to comply may result in serious injury or death to personnel.

FLOOR PANEL (FRONT) REMOVAL AND INSTALLATION - (CONTINUED)

REMOVAL

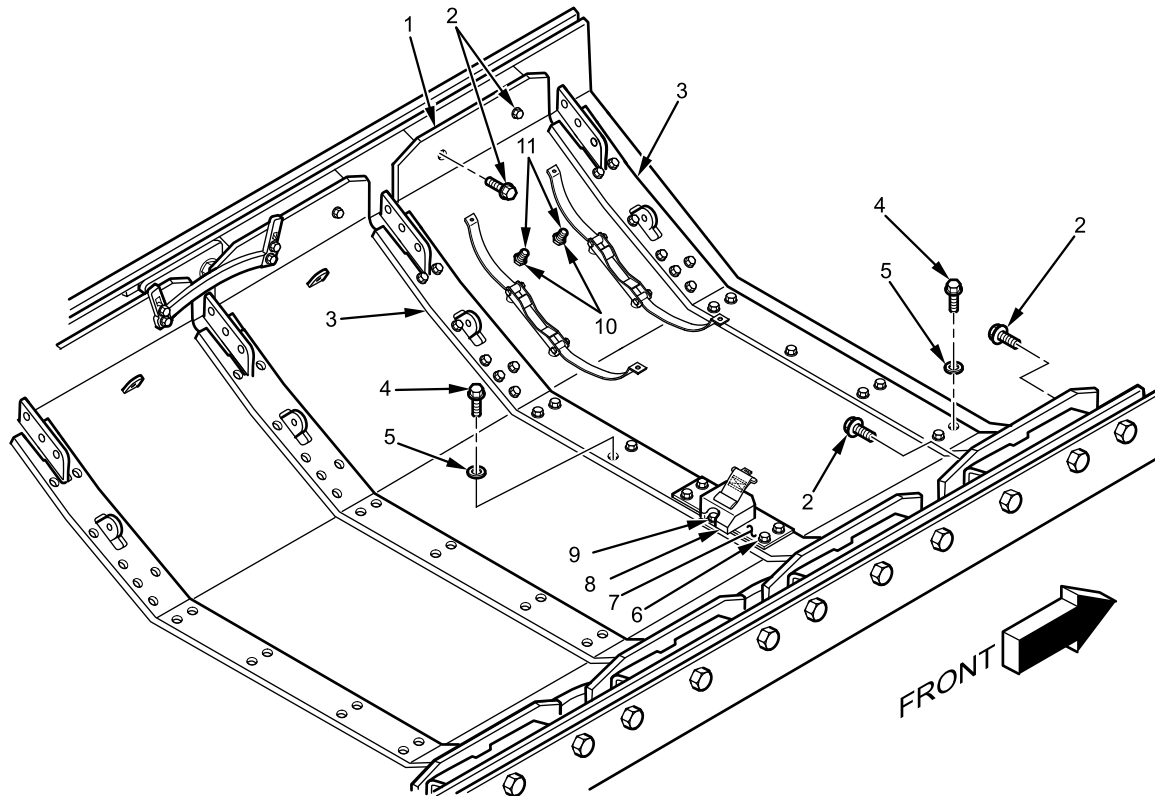

B231810883

Figure 1. Front Floor Panel.

1. Remove two bolts (Figure 1, Item 9) and washers from gunner platform retractor (Figure 1, Item 8).
2. Remove four bolts (Figure 1, Item 6) and washers from gunner platform retractor bracket (Figure 1, Item 7). Remove gunner platform retractor bracket.
3. Remove two nuts (Figure 1, Item 10) from Fire Suppression System (FSS) fittings (Figure 1, Item 11).
4. Remove 44 bolts (Figure 1, Item 4), flat washers (Figure 1, Item 5), and two overlap panels (Figure 1, Item 3) from front floor panel (Figure 1, Item 1).
5. Remove four bolts (Figure 1, Item 2) from front floor panel (Figure 1, Item 1).

FLOOR PANEL (FRONT) REMOVAL AND INSTALLATION - (CONTINUED)

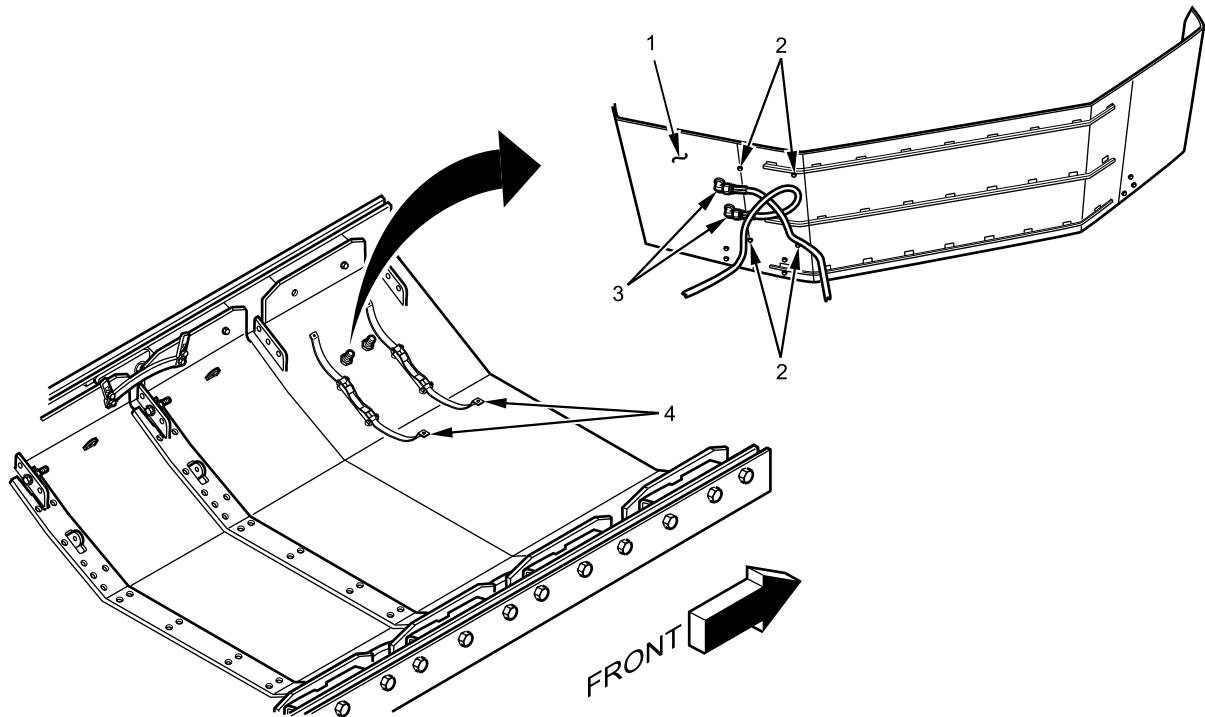

B231810885

Figure 2. Front Floor Panel Bottom.

6. With assistant, lift up front floor panel (Figure 2, Item 1).
7. Remove two FSS fittings (Figure 2, Item 3) from front floor panel (Figure 2, Item 1).
8. Remove four bolts (Figure 2, Item 2) from FSS bottle support brackets (Figure 2, Item 4).
9. Remove two FSS bottle support brackets (Figure 2, Item 4) from front floor panel (Figure 2, Item 1).
10. Remove front floor panel (Figure 2, Item 1) from vehicle.

END OF TASK

FLOOR PANEL (FRONT) REMOVAL AND INSTALLATION - (CONTINUED)

INSTALLATION

WARNING



Corrosion preventive compound is toxic. Use only in well-ventilated area. Do not get in eyes; wear chemical safety goggles and full-face shield when using. Avoid contact with skin and wear rubber or plastic, solvent-resistant gloves. In case of contact, remove contaminated clothing and immediately wash area with soap and water. If compound contacts eyes, flush eyes with large amounts of water for at least 15 minutes and get immediate medical attention. If swallowed, do not induce vomiting; contact a physician immediately. Failure to comply may result in serious injury or death to personnel.

NOTE

Apply corrosion preventive compound to all bolts prior to installation.

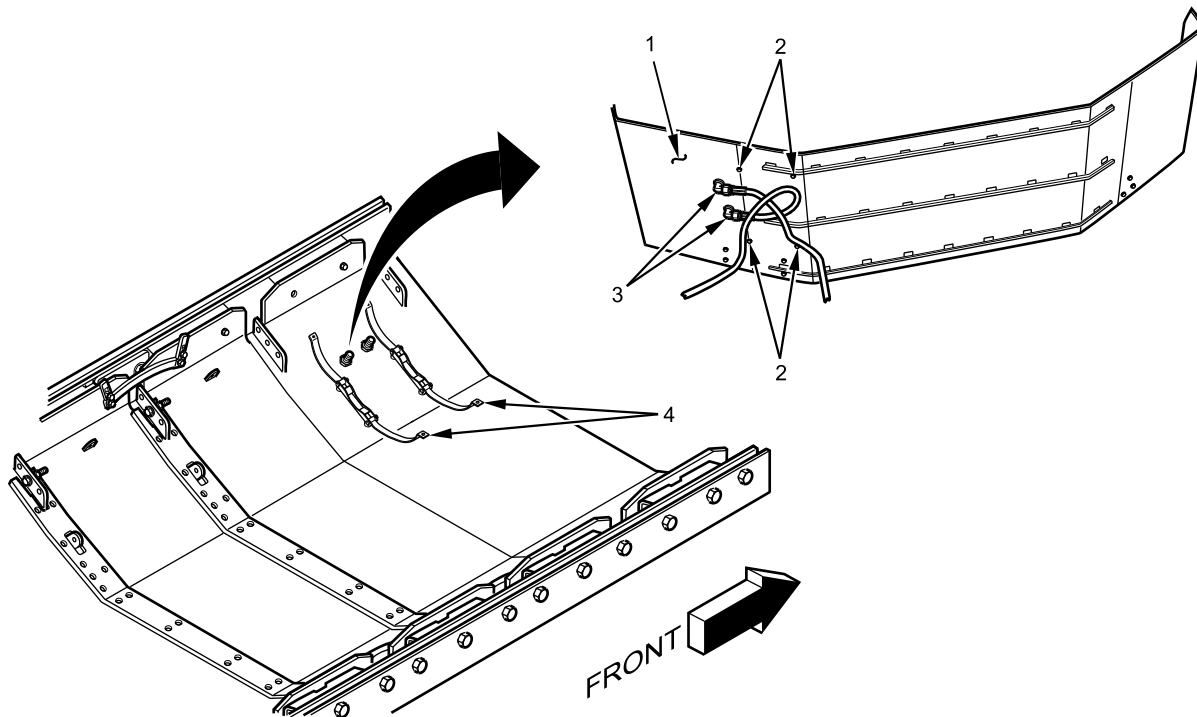

B231810885

Figure 3. Front Floor Panel Bottom.

1. With assistant, position front floor panel (Figure 3, Item 1) vertically in vehicle.
2. Install two FSS bottle support brackets (Figure 3, Item 4) on front floor panel (Figure 3, Item 1) with four bolts (Figure 3, Item 2) and washers. Tighten securely.
3. Install two FSS fittings (Figure 3, Item 3) on front floor panel (Figure 3, Item 1) with two nuts (Figure 4, Item 10). Tighten nuts securely.

FLOOR PANEL (FRONT) REMOVAL AND INSTALLATION - (CONTINUED)

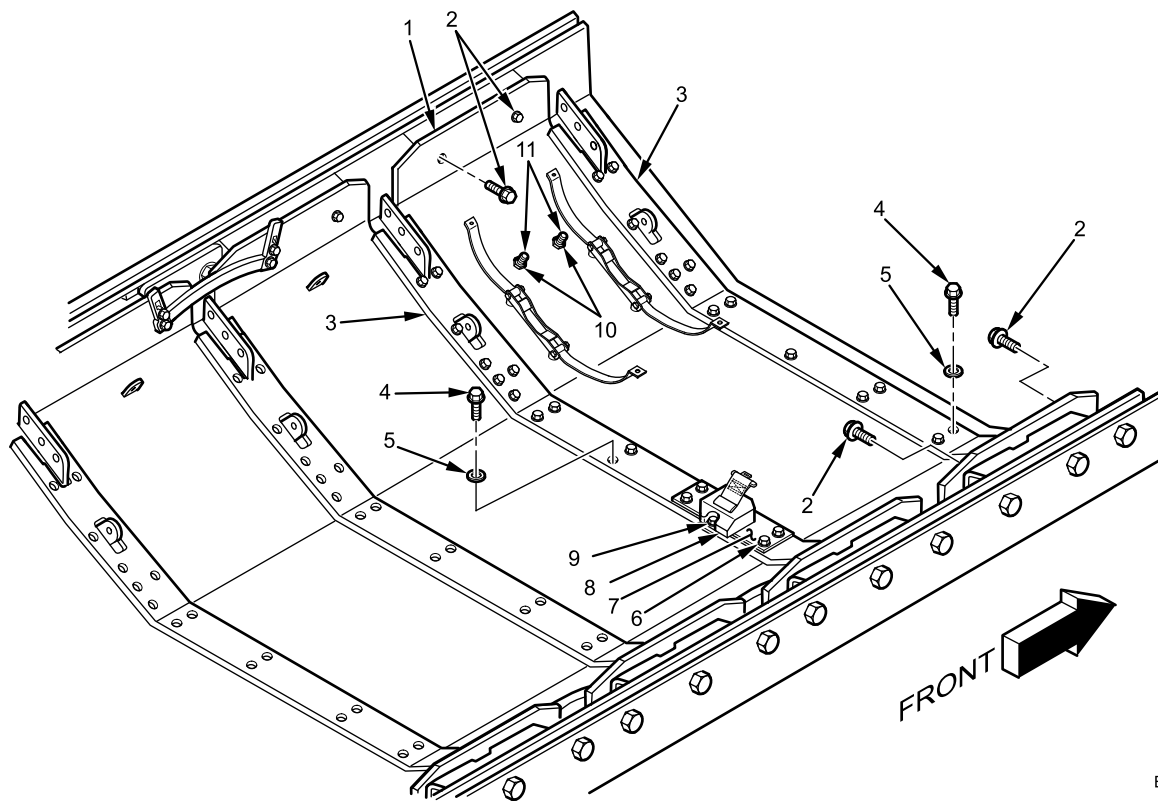

B231810883

Figure 4. Front Floor Panel.

4. Install front floor panel (Figure 4, Item 1) with four bolts (Figure 4, Item 2). Tighten securely.
5. Position two overlap panels (Figure 4, Item 3) into vehicle and secure with 44 flat washers (Figure 4, Item 5) and bolts (Figure 4, Item 4). Tighten securely.
6. Install gunner platform retractor bracket (Figure 4, Item 7) with four bolts (Figure 4, Item 6) and washers. Tighten securely.
7. Install gunner platform retractor (Figure 4, Item 8) with two bolts (Figure 4, Item 9) and washers. Tighten securely.

END OF TASK

FLOOR PANEL (FRONT) REMOVAL AND INSTALLATION - (CONTINUED)**FOLLOW-ON MAINTENANCE**

1. Install front passenger seat floor bracket (WP 0665).
2. Install driver seat (WP 0663).
3. Install front passenger seat (WP 0666).
4. Install LSS box (WP 0761).
5. Install FSS cabin dispersion cylinder (WP 0745).
6. Install communication rack (WP 0667).
7. Install gunner platform (WP 0668).
8. Turn MAIN POWER switch on (TM 9-2355-106-10).
9. Raise rear/door ramp (TM 9-2355-106-10).
10. Remove wheel chocks (TM 9-2355-106-10).

END OF TASK**END OF WORK PACKAGE**

FIELD MAINTENANCE**FLOOR PANEL (FRONT CENTER) REMOVAL AND INSTALLATION**

INITIAL SETUP:**Tools and Special Tools**

General Mechanic's Tool Kit (GMTK)
(WP 0795, Item 37)

Materials/Parts

Compound (WP 0794, Item 13)
Goggles, industrial (WP 0794, Item 20)
Face shield, industrial (WP 0794, Item 16)
Gloves (WP 0794, Item 18)
Gloves (WP 0794, Item 19)

Personnel Required

Maintainer (2)

References

TM 9-2355-106-10
TM 9-2355-106-23P
WP 0786

WP 0782

Equipment Condition

Parking brake set (TM 9-2355-106-10)
Transmission set in NEUTRAL (N) (TM 9-2355-106-10)
Engine off (TM 9-2355-106-10)
MAIN POWER switch off (TM 9-2355-106-10)
Wheels chocked (TM 9-2355-106-10)
Rear door/ramp lowered (TM 9-2355-106-10)
Litter arm storage bracket removed (WP 0679)
Front litter arm mount plate and arm support removed (WP 0680)
Crew seatbelts removed (WP 0664)
Crew seats removed (WP 0666)
Fire Suppression System (FSS) cabin cylinder removed (WP 0745)

FLOOR PANEL (FRONT CENTER) REMOVAL AND INSTALLATION - (CONTINUED)**REMOVAL**

1. Remove 48 bolts (Figure 1, Item 7), flat washers (Figure 1, Item 8), two overlap panels (Figure 1, Item 6), and gunner rack retractor plate (if equipped) from inside of vehicle.

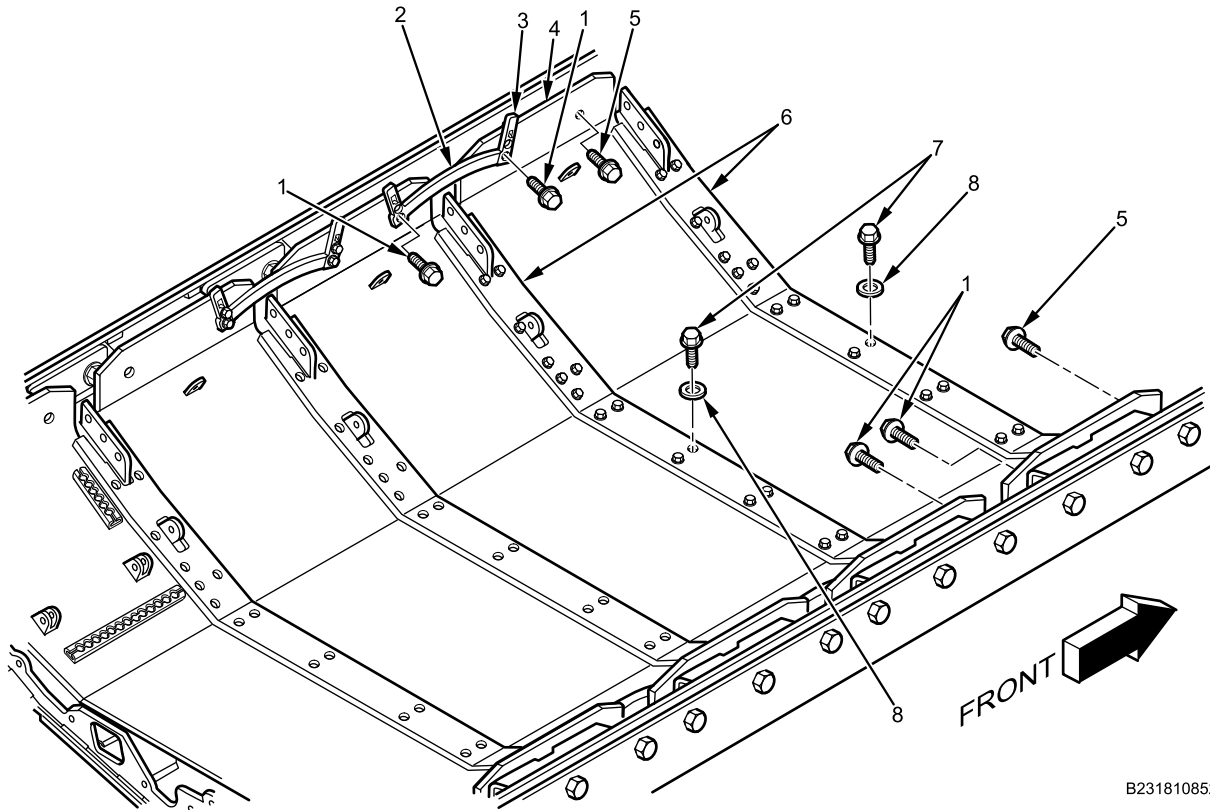

B231810852

Figure 1. Front Center Floor Panel.

2. Remove four bolts (Figure 1, Item 1) and two safety belt brackets (Figure 1, Item 2).
3. Remove two remaining front bolts (Figure 1, Item 5) from floor panel (Figure 1, Item 4).

WARNING

Armor parts are heavy. Use care when removing or installing. Do not attempt to lift without an assistant. Wear gloves. Failure to comply may result in serious injury or death to personnel.

4. With assistant, remove front center floor panel (Figure 1, Item 4) from vehicle.

END OF TASK

FLOOR PANEL (FRONT CENTER) REMOVAL AND INSTALLATION - (CONTINUED)**INSTALLATION****WARNING**

Corrosion preventive compound is toxic. Use only in well-ventilated area. Do not get in eyes; wear chemical safety goggles and full-face shield when using. Avoid contact with skin and wear rubber or plastic, solvent-resistant gloves. In case of contact, remove contaminated clothing and immediately wash area with soap and water. If compound contacts eyes, flush eyes with large amounts of water for at least 15 minutes and get immediate medical attention. If swallowed, do not induce vomiting; contact a physician immediately. Failure to comply may result in serious injury or death to personnel.

NOTE

Apply corrosion preventive compound to all bolts prior to installation.

1. With assistant, position front center floor panel (Figure 1, Item 4) in vehicle.
2. Align safety belt bracket (Figure 1, Item 2) with bolt hole in floor panel (Figure 1, Item 4). Secure with two bolts (Figure 1, Item 1). Repeat for other side of vehicle.
3. Install two bolts (Figure 1, Item 5) into front bolt holes of floor panel (Figure 1, Item 4). Repeat for other side of vehicle.
4. Position two overlap panels (Figure 1, Item 6) and gunner rack retractor plate (if equipped). Secure with 48 flat washers (Figure 1, Item 8) and bolts (Figure 1, Item 7).

END OF TASK**FOLLOW-ON MAINTENANCE**

1. Install crew seats (WP 0666).
2. Install crew seatbelts (WP 0664).
3. Install front litter arm mount plate and arm support (WP 0680).
4. Install litter arm storage bracket (WP 0679).
5. Install FSS cabin cylinder (WP 0745).
6. Turn MAIN POWER switch on (TM 9-2355-106-10).
7. Raise rear door/ramp (TM 9-2355-106-10).
8. Turn MAIN POWER switch off (TM 9-2355-106-10).
9. Remove wheel chocks (TM 9-2355-106-10).

END OF TASK**END OF WORK PACKAGE**

FIELD MAINTENANCE**CENTER FLOOR PANEL REMOVAL AND INSTALLATION**

INITIAL SETUP:**Tools and Special Tools**

General Mechanic's Tool Kit (GMTK)
(WP 0795, Item 37)

TM 9-2355-106-23P

WP 0786

WP 0782

Materials/Parts

Compound (WP 0794, Item 13)
Goggles, industrial (WP 0794, Item 20)
Face shield, industrial (WP 0794, Item 16)
Gloves (WP 0794, Item 18)
Gloves (WP 0794, Item 19)

Equipment Condition

Parking brake set (TM 9-2355-106-10)
Transmission set in NEUTRAL (N) (TM
9-2355-106-10)
Engine off (TM 9-2355-106-10)
MAIN POWER switch off (TM 9-2355-106-10)
Wheels chocked (TM 9-2355-106-10)
Rear door ramp lowered (TM 9-2355-106-10)
Litter arm storage bracket removed (WP 0679)
Crew seatbelts removed (WP 0664)
Crew seats removed (WP 0666)

Personnel Required

Maintainer (2)

References

TM 9-2355-106-10

CENTER FLOOR PANEL REMOVAL AND INSTALLATION - (CONTINUED)**REMOVAL**

1. Remove 48 bolts (Figure 1, Item 4), flat washers (Figure 1, Item 5), and two overlap panels (Figure 1, Item 3) from floor of vehicle.

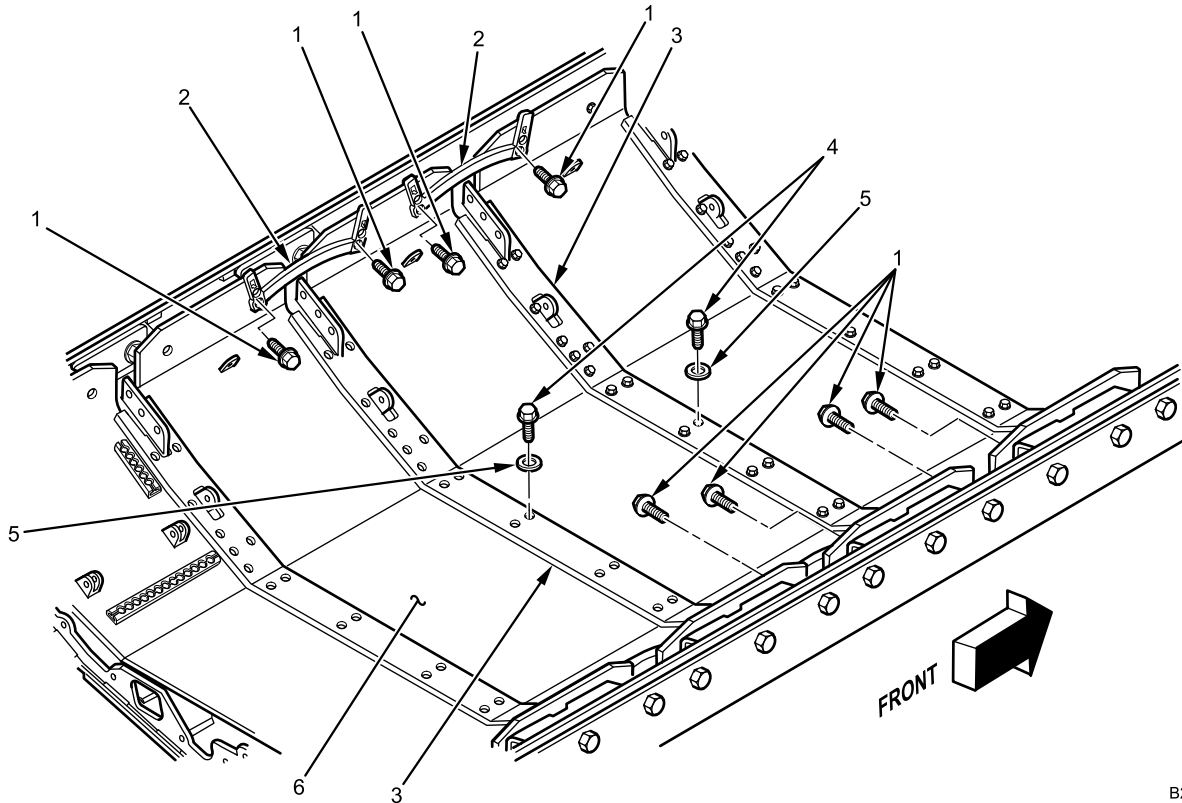

B231810851

Figure 1. Center Floor Panel.

2. Remove four bolts (Figure 1, Item 1), and two seatbelt brackets (Figure 1, Item 3). Repeat for other side of vehicle.

WARNING

Armor parts are heavy. Use care when removing or installing. Do not attempt to lift without an assistant. Wear gloves. Failure to comply may result in serious injury or death to personnel.

3. With assistant, remove center floor panel (Figure 1, Item 6) from vehicle.

END OF TASK

CENTER FLOOR PANEL REMOVAL AND INSTALLATION - (CONTINUED)**INSTALLATION****WARNING**

Corrosion preventive compound is toxic. Use only in well-ventilated area. Do not get in eyes; wear chemical safety goggles and full-face shield when using. Avoid contact with skin and wear rubber or plastic, solvent-resistant gloves. In case of contact, remove contaminated clothing and immediately wash area with soap and water. If compound contacts eyes, flush eyes with large amounts of water for at least 15 minutes and get immediate medical attention. If swallowed, do not induce vomiting; contact a physician immediately. Failure to comply may result in serious injury or death to personnel.

Armor parts are heavy. Use care when removing or installing. Do not attempt to lift without an assistant. Wear gloves. Failure to comply may result in serious injury or death to personnel.

NOTE

Apply corrosion preventive compound to all bolts prior to installation.

1. With assistant, position center floor panel (Figure 1, Item 6) in vehicle.
2. Align two seatbelt brackets (Figure 1, Item 2) with boltholes in floor panel (Figure 1, Item 6). Secure with bolts (Figure 1, Item 1). Repeat for other side of vehicle.
3. Position two overlap panels (Figure 1, Item 3) and secure with 48 flat washers (Figure 1, Item 5) and bolts (Figure 1, Item 4).

END OF TASK**FOLLOW-ON MAINTENANCE**

1. Install crew seats (WP 0666).
2. Install crew seatbelts (WP 0664).
3. Install litter arm storage bracket (WP 0679).
4. Raise rear door ramp (TM 9-2355-106-10).
5. Turn MAIN POWER switch off (TM 9-2355-106-10).
6. Remove wheel chocks (TM 9-2355-106-10).

END OF TASK**END OF WORK PACKAGE**

FIELD MAINTENANCE**REAR CENTER FLOOR PANEL REMOVAL AND INSTALLATION**

INITIAL SETUP:**Tools and Special Tools**

General Mechanic's Tool Kit (GMTK)
(WP 0795, Item 37)
Lifting device (WP 0795, Item 67)
Sling, nylon (WP 0795, Item 91)

TM 9-2355-106-23P

WP 0786

WP 0782

Materials/Parts

Gloves (WP 0794, Item 18)
Goggles, industrial (WP 0794, Item 20)
Faceshield, industrial (WP 0794, Item 16)
Compound (WP 0794, Item 13)

Equipment Condition

Parking brake set (TM 9-2355-106-10)
Transmission set in NEUTRAL (N) (TM
9-2355-106-10)
Engine off (TM 9-2355-106-10)
MAIN POWER switch off (TM 9-2355-106-10)
Wheels chocked (TM 9-2355-106-10)
Litter arm storage bracket removed (WP 0679)
Rear crew seats removed (WP 0666)
Rear crew seatbelts removed (WP 0664)

Personnel Required

Maintainer - (3)

ReferencesTM 9-2355-106-10

REAR CENTER FLOOR PANEL REMOVAL AND INSTALLATION - (CONTINUED)**REMOVAL****CAUTION**

Damage to floor panel fasteners may occur due to weight of floor panel. It may be necessary to use lifting straps and lifting device to decrease tension on floor panel fasteners during removal and installation.

1. Remove four nuts (Figure 1, Item 1) and bolts (Figure 1, Item 11) from four body support plates. Left side floor plates shown, right side floor plates hidden from view.

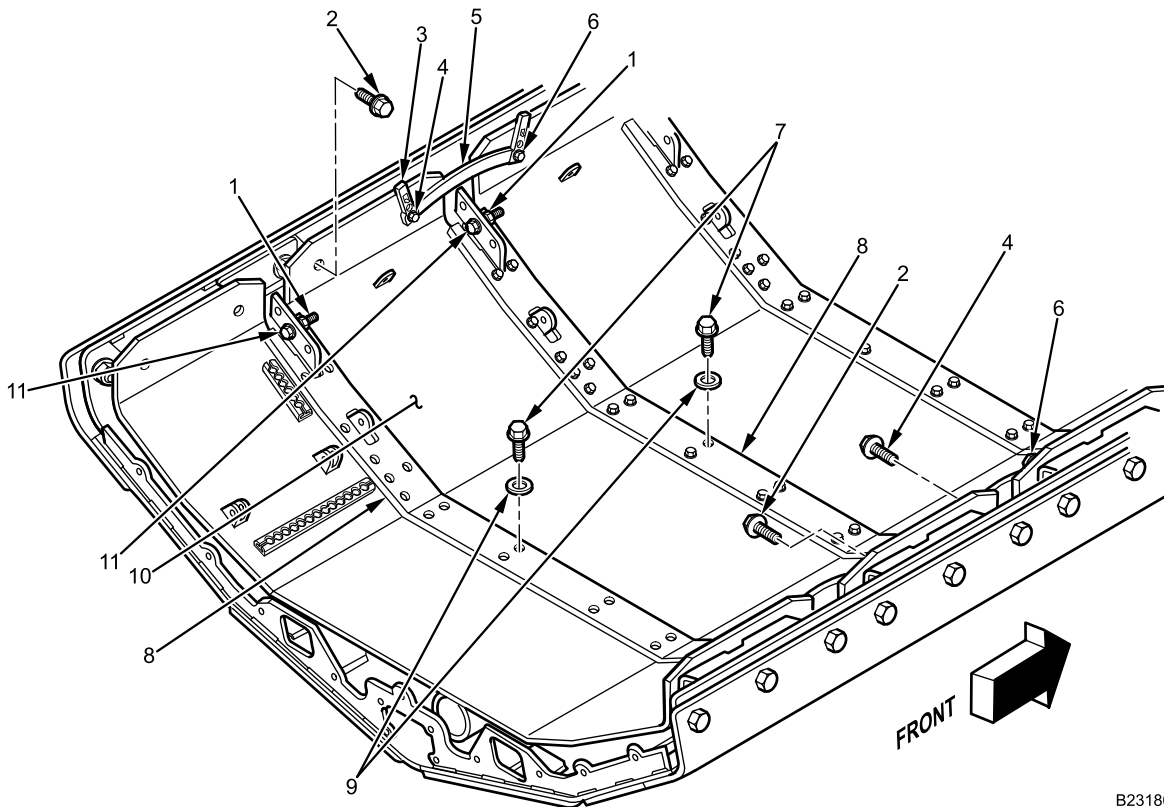

B231803370

Figure 1. Rear Center Floor Panel.

2. With assistants, remove 48 bolts (Figure 1, Item 7) and flat washers (Figure 1, Item 9), from two overlap panels (Figure 1, Item 8). Remove two overlap panels from vehicle.
3. Remove two bolts (Figure 1, Item 2) from sides of rear center floor panel (Figure 1, Item 10).
4. Remove two bolts (Figure 1, Item 4) securing two safety belt connectors (Figure 1, Item 3), and two safety belt connector supports (Figure 1, Item 5), to floor panel. Remove two safety belt connectors from vehicle. Left side safety belt connectors and supports shown, right side safety belt connectors and supports hidden from view.
5. Loosen two bolts (Figure 1, Item 6) securing two safety belt connector supports (Figure 1, Item 5) to center floor panel. Swing safety belt connector supports out of the way for clearance during removal of rear center floor panel. Left side safety belt connector supports shown, right side safety belt connector supports hidden from view.
6. With assistants, remove rear center floor panel (Figure 1, Item 10) from vehicle.

END OF TASK

REAR CENTER FLOOR PANEL REMOVAL AND INSTALLATION - (CONTINUED)**INSTALLATION****WARNING**

Corrosion preventive compound is toxic. Use only in well-ventilated area. Do not get in eyes; wear chemical safety goggles and full-face shield when using. Avoid contact with skin and wear rubber or plastic, solvent-resistant gloves. In case of contact, remove contaminated clothing and immediately wash area with soap and water. If compound contacts eyes, flush eyes with large amounts of water for at least 15 minutes and get immediate medical attention. If swallowed, do not induce vomiting; contact a physician immediately. Failure to comply may result in serious injury or death to personnel.

CAUTION

Damage to floor panel fasteners may occur due to weight of floor panel. It may be necessary to use lifting straps and lifting device to decrease tension on floor panel fasteners during removal and installation.

NOTE

Apply corrosion preventive compound to all bolts prior to installation.

1. With assistants, position rear center floor panel (Figure 1, Item 10) in vehicle.
2. Install two bolts (Figure 1, Item 2) on sides of rear center floor panel. Do not tighten.
3. Swing two safety belt connector supports (Figure 1, Item 5) into position and install two safety belt connectors (Figure 1, Item 3) with two bolts (Figure 1, Item 4) and tighten securely.
4. Tighten four bolts (Figure 1, Item 2 and 6) securely.
5. With assistants, install two overlap panels (Figure 1, Item 8) with 48 bolts (Figure 1, Item 7) and flat washers (Figure 1, Item 9) and tighten securely.
6. Install four bolts (Figure 1, Item 11) and nuts (Figure 1, Item 1) on body support plates and tighten securely.

END OF TASK**FOLLOW-ON MAINTENANCE**

1. Install rear crew seatbelts (WP 0664).
2. Install rear crew seats (WP 0666).
3. Install litter arm storage bracket (WP 0679).
4. Remove wheel chocks (TM 9-2355-106-10).

END OF TASK**END OF WORK PACKAGE**

FIELD MAINTENANCE**REAR FLOOR PANEL REMOVAL AND INSTALLATION**

INITIAL SETUP:**Tools and Special Tools**

General Mechanic's Tool Kit (GMTK)
(WP 0795, Item 37)

Materials/Parts

Compound (WP 0794, Item 13)
Goggles, industrial (WP 0794, Item 20)
Face shield, industrial (WP 0794, Item 16)
Gloves (WP 0794, Item 18)
Gloves (WP 0794, Item 19)

Personnel Required

Maintainer (2)

References

TM 9-2355-106-10
TM 9-2355-106-23P
WP 0786
WP 0782

Equipment Condition

Parking brake set (TM 9-2355-106-10)
Transmission set in NEUTRAL (N) (TM 9-2355-106-10)
Engine off (TM 9-2355-106-10)
MAIN POWER switch off (TM 9-2355-106-10)
Wheels chocked (TM 9-2355-106-10)
Rear door ramp lowered (TM 9-2355-106-10)
Litter arm storage bracket removed (WP 0679)
Rear litter arm mount plate and arm support removed (WP 0681)
Rear crew seats removed (WP 0666)
Rear crew seatbelts removed (WP 0664)
Rear door hydraulic pump removed (WP 0692[Push-Type Operation]) or (WP 0693[Pull-Type Operation])
Rear communication rack removed (WP 0670)

REAR FLOOR PANEL REMOVAL AND INSTALLATION - (CONTINUED)**REMOVAL**

1. Remove 24 bolts (Figure 1, Item 4), flat washers (Figure 1, Item 5), and overlap panel (Figure 1, Item 3) from floor of vehicle.

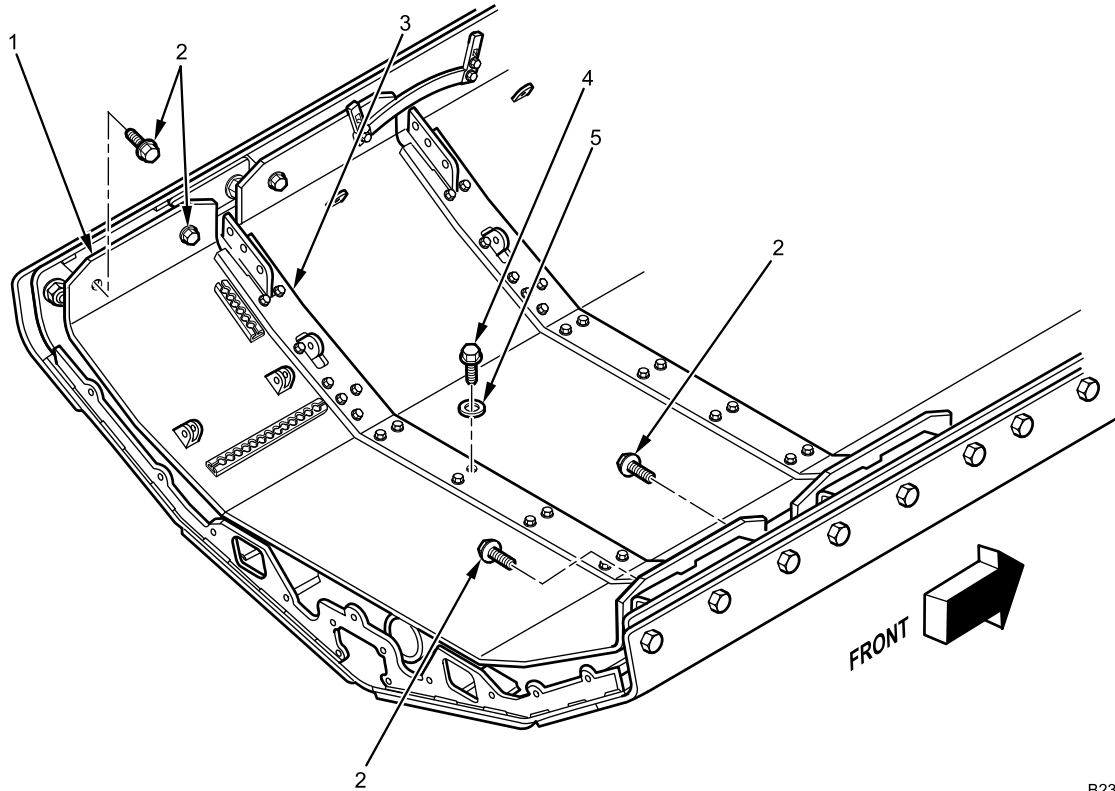

B231810853

Figure 1. Rear Floor Panel.

NOTE

If rear communication rack has been removed prior to performing this procedure, two left side floor panel bolts will have already been removed. Remove two remaining bolts located on right side of vehicle.

2. Remove four bolts (Figure 1, Item 2) securing floor panel (Figure 1, Item 1) to vehicle.

WARNING

Armor parts are heavy. Use care when removing or installing. Do not attempt to lift without an assistant. Wear gloves. Failure to comply may result in serious injury or death to personnel.

3. With assistant, remove floor panel (Figure 1, Item 1) from vehicle.

END OF TASK

REAR FLOOR PANEL REMOVAL AND INSTALLATION - (CONTINUED)**INSTALLATION****WARNING**

Corrosion preventive compound is toxic. Use only in well-ventilated area. Do not get in eyes; wear chemical safety goggles and full-face shield when using. Avoid contact with skin and wear rubber or plastic, solvent-resistant gloves. In case of contact, remove contaminated clothing and immediately wash area with soap and water. If compound contacts eyes, flush eyes with large amounts of water for at least 15 minutes and get immediate medical attention. If swallowed, do not induce vomiting; contact a physician immediately. Failure to comply may result in serious injury or death to personnel.

Armor parts are heavy. Use care when removing or installing. Do not attempt to lift without an assistant. Wear gloves. Failure to comply may result in serious injury or death to personnel.

NOTE

Apply corrosion preventive compound to all bolts prior to installation.

If vehicle is equipped with rear communication rack, communication rack boltholes must align with boltholes in floor panel on left side of vehicle.

1. With assistant, install floor panel wp3996fig1 with four bolts (Figure 1, Item 2) and tighten bolts securely.
2. Install overlap panel (Figure 1, Item 3) with 24 flat washers (Figure 1, Item 5) and bolts (Figure 1, Item 4). Tighten bolts securely.

END OF TASK

REAR FLOOR PANEL REMOVAL AND INSTALLATION - (CONTINUED)**FOLLOW-ON MAINTENANCE**

1. Install crew seats (WP 0666).
2. Install rear crew seatbelts (WP 0664).
3. Install rear door hydraulic pump (WP 0692 [Push-Type Operation]) or (WP 0693 [Pull-Type Operation]).
4. Install rear communication rack (WP 0670).
5. Install rear litter arm mount plate and arm support (WP 0681).
6. Install litter arm storage bracket (WP 0679).
7. Raise rear door ramp (TM 9-2355-106-10).
8. Remove wheel chocks (TM 9-2355-106-10).

END OF TASK**END OF WORK PACKAGE**

FIELD MAINTENANCE

DRIVER SEAT REMOVAL AND INSTALLATION

INITIAL SETUP:

Tools and Special Tools

General Mechanic's Tool Kit (GMTK)
(WP 0795, Item 37)

References

TM 9-2355-106-10
TM 9-2355-106-23P
WP 0782

Equipment Condition

Parking brake set (TM 9-2355-106-10)
Transmission set in NEUTRAL (N) (TM
9-2355-106-10)
Engine off (TM 9-2355-106-10)
MAIN POWER switch off (TM 9-2355-106-10)
Wheels chocked (TM 9-2355-106-10)

REMOVAL

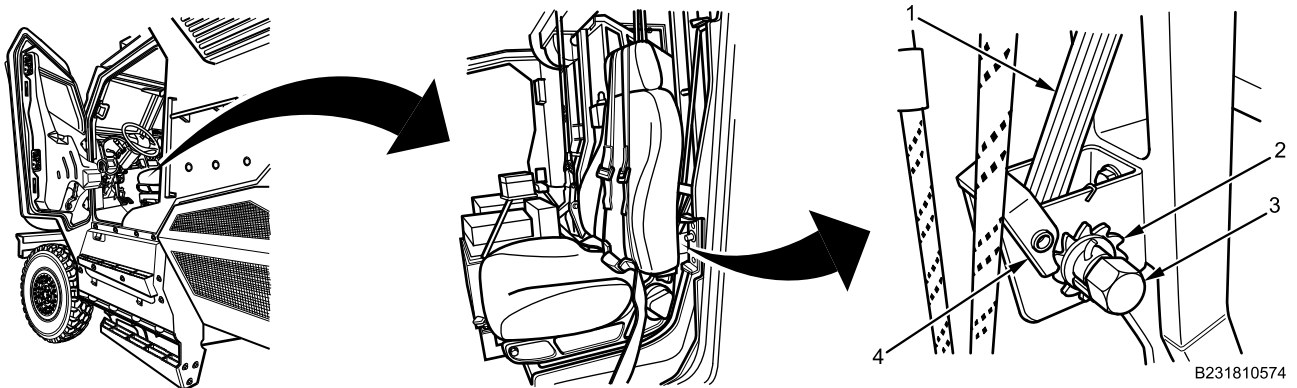

Figure 1. Rear Seat Hanger Safety Strap.

1. Move driver seat forward to gain access to rear of seat.
2. Maintain tension on rear seat hanger safety strap (Figure 1, Item 1) by holding nut (Figure 1, Item 3) in place.
3. Using a hammer, release latch (Figure 1, Item 4) from ratchet (Figure 1, Item 2). Release tension on rear seat hanger safety strap (Figure 1, Item 1) and push in release latch to release tension.
4. Pull retaining pin (Figure 2, Item 1) from seat strap clevis pin (Figure 2, Item 2) at top rear of seat bracket (Figure 2, Item 3).

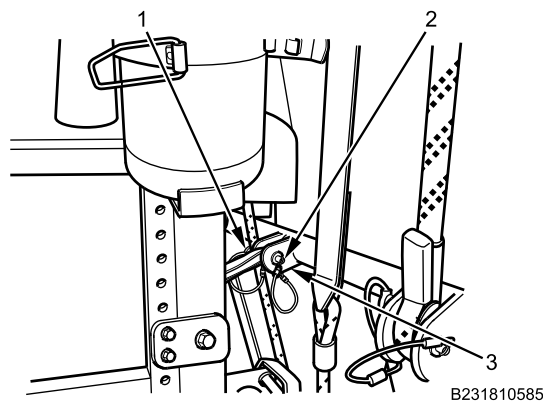
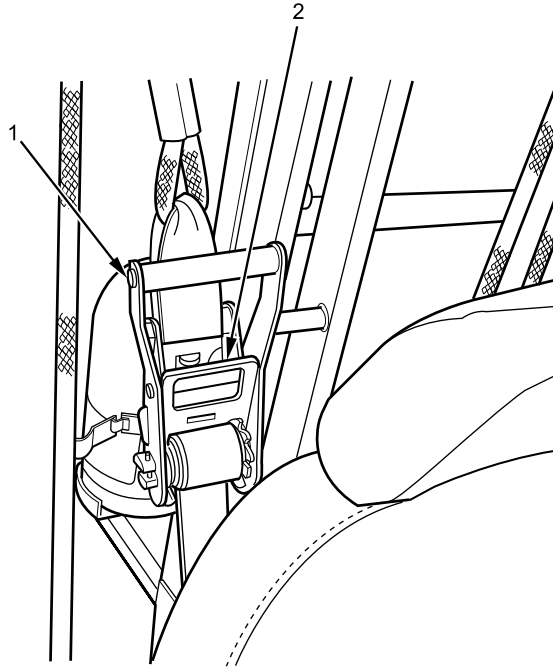

Figure 2. Seat Upper Strap.

DRIVER SEAT REMOVAL AND INSTALLATION - (CONTINUED)

5. Remove clevis pin (Figure 2, Item 2).
6. Place hand on handle (Figure 3, Item 1), lift up on release lever (Figure 3, Item 2), and swing handle down.



B231810576

Figure 3. Suspension Lever.

7. With handle (Figure 4, Item 1) in down position, pull down on release lever (Figure 4, Item 2) to release tension on rope (Figure 4, Item 3).

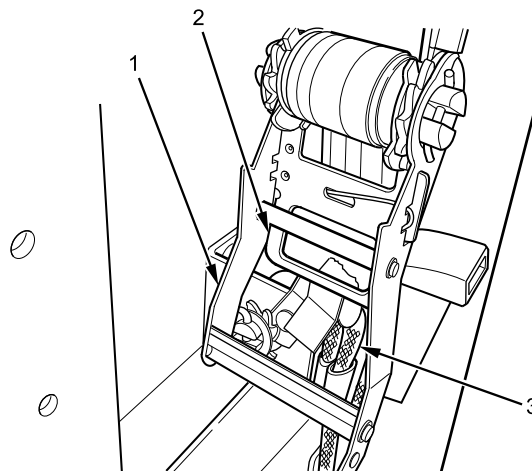

B230603511

Figure 4. Seat Suspension Lever Release.

DRIVER SEAT REMOVAL AND INSTALLATION - (CONTINUED)**NOTE**

Driver seat right side clevis pin shown; driver seat left side clevis pin same.

8. Remove retaining pin (Figure 5, Item 1) from clevis pins (Figure 5, Item 2) on right and left seat suspension retainers.

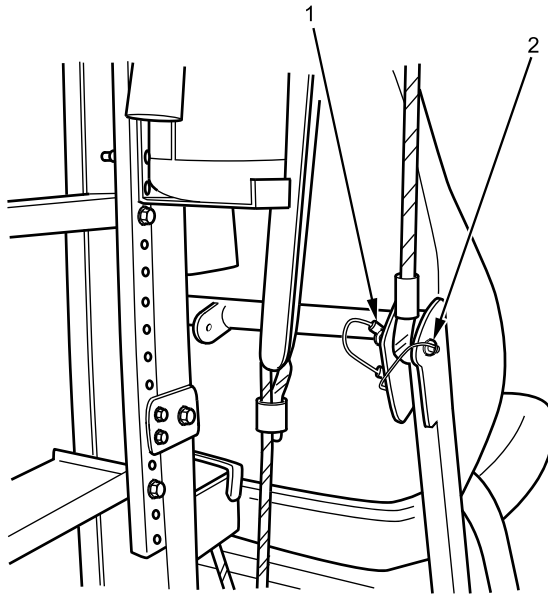

B231810577

Figure 5. Seat Suspension Retainer.

9. Remove clevis pin (Figure 5, Item 1) from right and left seat suspension.

DRIVER SEAT REMOVAL AND INSTALLATION - (CONTINUED)**NOTE**

Note seatbelt routing during removal for installation.

Driver seat left side shown; driver seat right side same.

10. Remove floor anchor pin (Figure 6, Item 1) from left and right floor anchors (Figure 6, Item 3) and remove straps (Figure 6, Item 2).

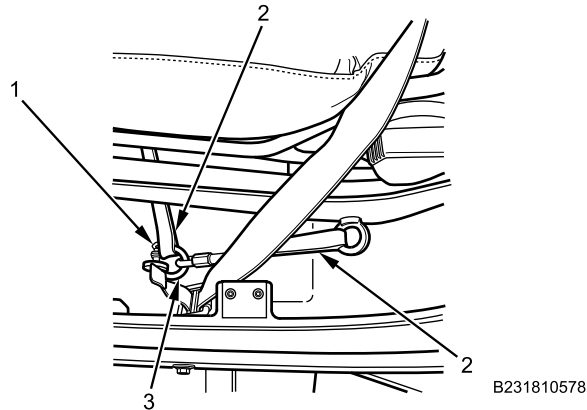
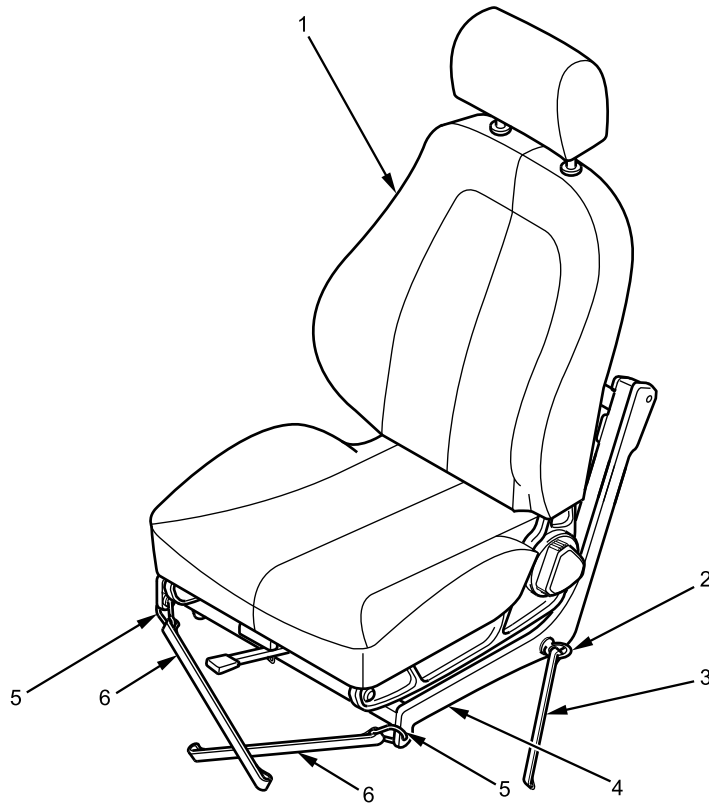

Figure 6. Floor Anchor.

11. Remove seat from vehicle.

END OF TASK

DRIVER SEAT REMOVAL AND INSTALLATION - (CONTINUED)**DISASSEMBLY**

B231810583

Figure 7. Driver Seat Rear Eyebolts.

1. Remove two rear strap eyebolts (Figure 7, Item 2), rear straps (Figure 7, Item 3), and nuts from left and right side of driver seat (Figure 7, Item 1).

DRIVER SEAT REMOVAL AND INSTALLATION - (CONTINUED)

2. Disconnect two carabiner clamps (Figure 7, Item 5) from driver seat suspension (Figure 7, Item 4) and remove two front floor straps (Figure 7, Item 6).

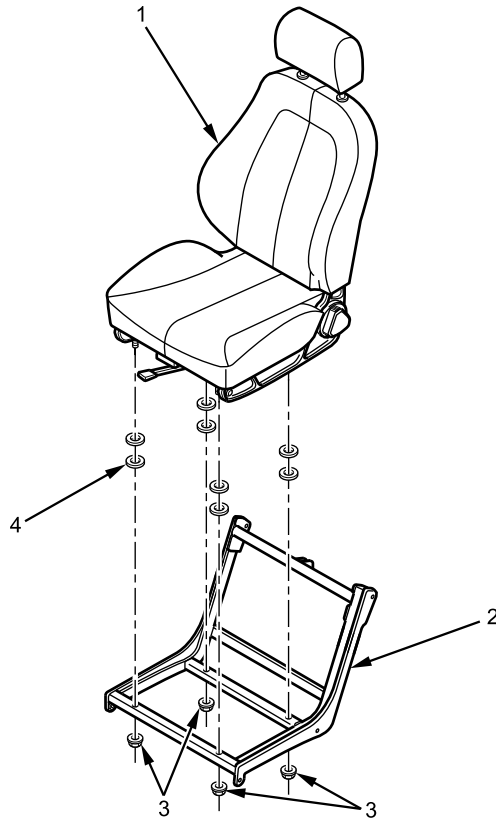

B231810584

Figure 8. Driver Seat and Suspension.

3. Remove four nuts (Figure 8, Item 3) and eight washers (Figure 8, Item 4) from driver seat (Figure 8, Item 1) and driver seat suspension (Figure 8, Item 2).

END OF TASK

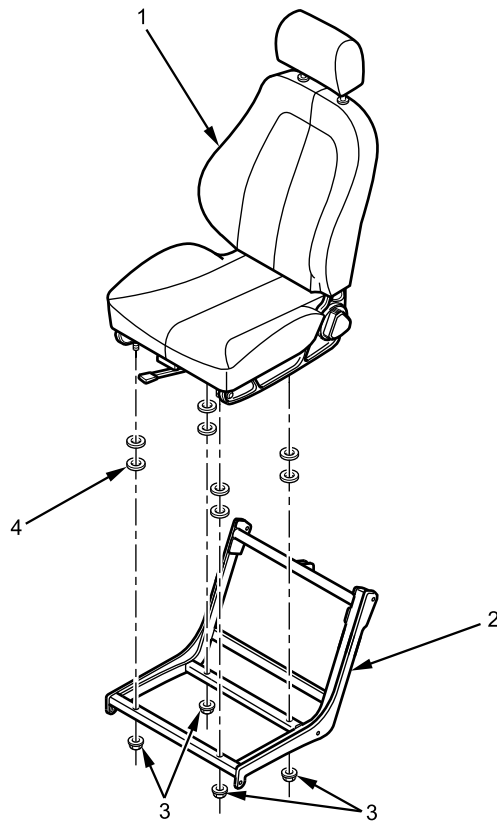
DRIVER SEAT REMOVAL AND INSTALLATION - (CONTINUED)**ASSEMBLY**

B231810584

Figure 9. Driver Seat and Suspension.

1. Install driver seat (Figure 9, Item 1) on driver seat suspension (Figure 9, Item 2) using four nuts (Figure 9, Item 3) and eight washers (Figure 9, Item 4). Tighten driver seat mounting nuts securely.

DRIVER SEAT REMOVAL AND INSTALLATION - (CONTINUED)

2. Install two floor straps (Figure 10, Item 6) on driver seat suspension (Figure 10, Item 4) with two carabiner clamps (Figure 10, Item 5).

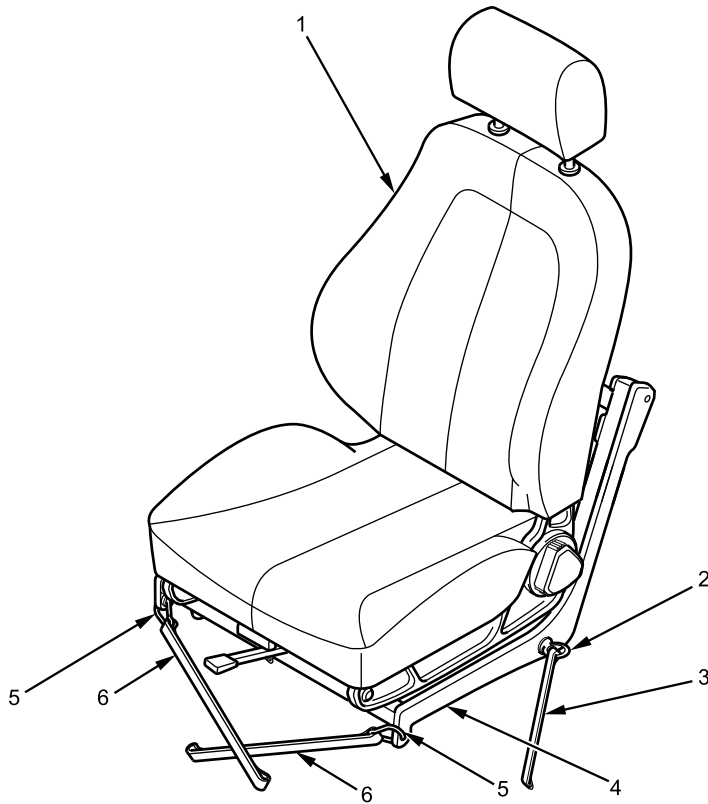

B231810583

Figure 10. Driver Seat Rear Eyebolt.

3. Install two rear eyebolts (Figure 10, Item 2), rear straps (Figure 10, Item 3), and nuts on left and right side of driver seat (Figure 10, Item 1). Tighten eyebolts securely.

END OF TASK

DRIVER SEAT REMOVAL AND INSTALLATION - (CONTINUED)**INSTALLATION****NOTE**

Use seat belt routing noted during removal process.

Driver seat left side shown; driver seat right side same.

1. Position straps (Figure 11, Item 2) on left and right floor anchors (Figure 11, Item 3) and install two floor anchor pins (Figure 11, Item 1).

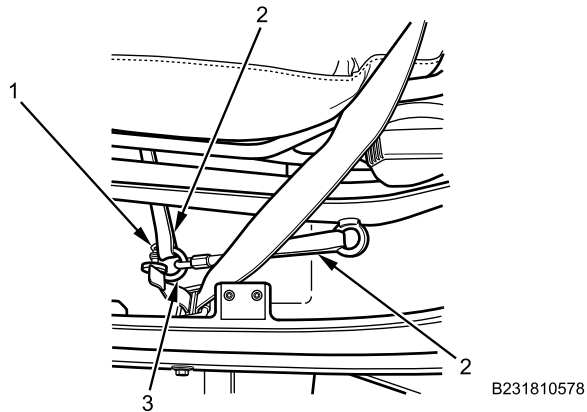
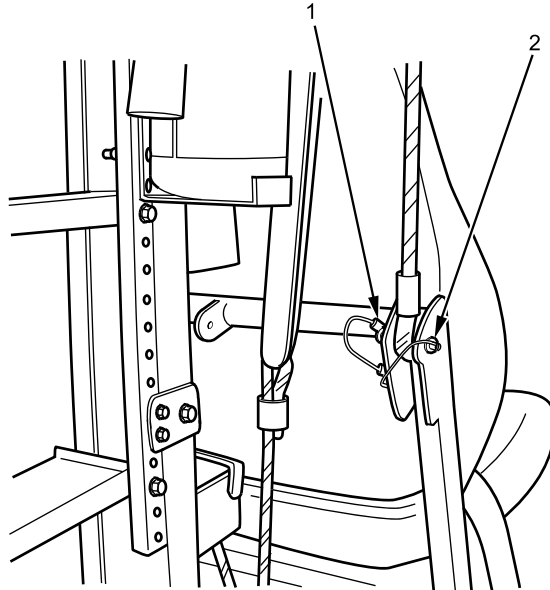

Figure 11. Floor Anchor.

DRIVER SEAT REMOVAL AND INSTALLATION - (CONTINUED)**NOTE**

Driver seat right clevis pin shown; driver seat left clevis pin same.

2. Install clevis pin (Figure 12, Item 2) through right seat suspension. Repeat for left side.



B231810577

Figure 12. Seat Suspension Retainer.

3. Install retaining pin (Figure 12, Item 1) on right clevis pin (Figure 12, Item 2). Repeat for left side.
4. Ensure handle (Figure 13, Item 1) is in down position and pull on strap (Figure 13, Item 3) to remove slack.

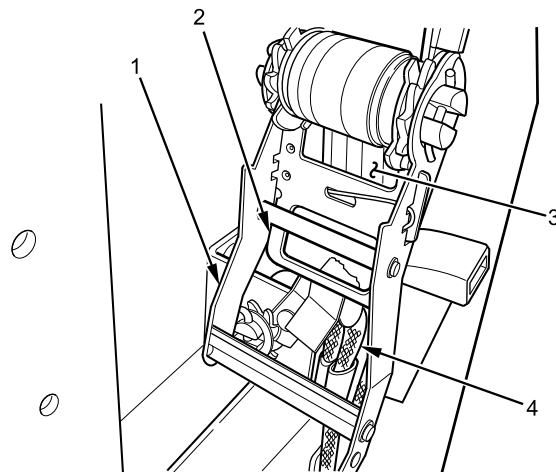

B230603510

Figure 13. Seat Suspension Lever Release.

5. Pull down on release lever (Figure 13, Item 2) and lift up on handle (Figure 13, Item 1) to begin ratcheting seat suspension handle until rope (Figure 13, Item 4) is tight.

DRIVER SEAT REMOVAL AND INSTALLATION - (CONTINUED)

6. Place handle (Figure 14, Item 1) in up position when rope is tightened. Ensure release lever (Figure 14, Item 2) is engaged in the down position.

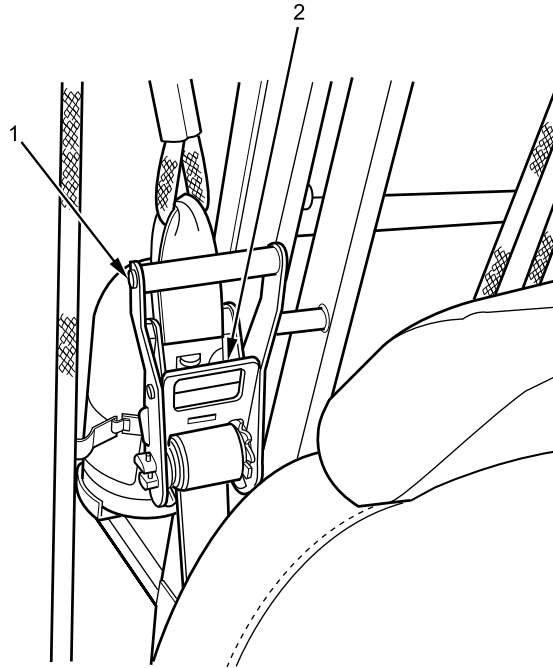

B231810576

Figure 14. Suspension Lever.

7. Position upper seat strap to seat bracket (Figure 15, Item 3).

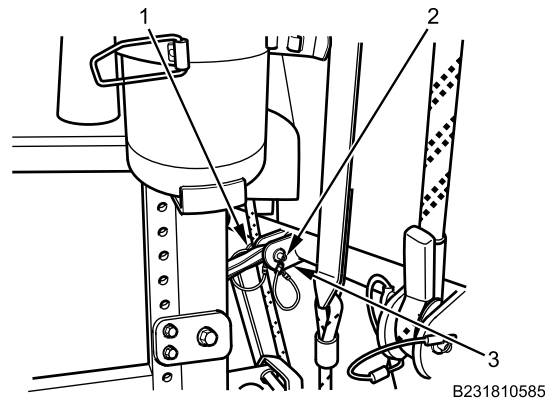

B231810585

Figure 15. Seat Upper Strap.

8. Insert clevis pin (Figure 15, Item 2) and retaining pin (Figure 15, Item 1).

DRIVER SEAT REMOVAL AND INSTALLATION - (CONTINUED)

9. Rotate nut (Figure 16, Item 2) to turn rear seat hanger safety strap (Figure 16, Item 1) until tight. Ensure latch (Figure 16, Item 3) is engaged.

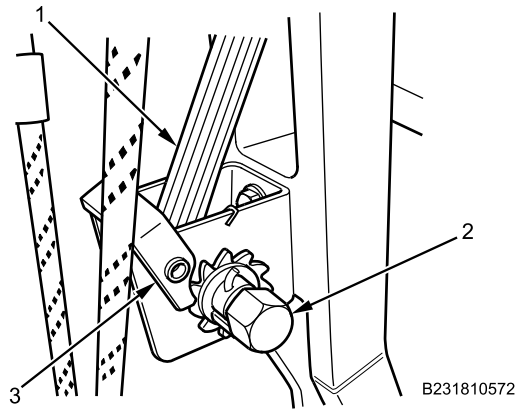

Figure 16. Rear Seat Hanger Safety Strap.

END OF TASK

FOLLOW-ON MAINTENANCE

1. Remove wheel chocks (TM 9-2355-106-10).

END OF TASK

END OF WORK PACKAGE

FIELD MAINTENANCE
SEATBELT REMOVAL AND INSTALLATION

INITIAL SETUP:**Tools and Special Tools**

General Mechanic's Tool Kit (GMTK)
(WP 0795, Item 37)
Wrench, torque, click, ratcheting, 15-75 lb-ft, 3/8-inch
drive (WP 0795, Item 145)

References

TM 9-2355-106-10
TM 9-2355-106-23P

WP 0782

Equipment Condition

Parking brake set (TM 9-2355-106-10)
Transmission set in NEUTRAL (N) (TM
9-2355-106-10)
Engine off (TM 9-2355-106-10)
MAIN POWER switch off (TM 9-2355-106-10)
Wheels chocked (TM 9-2355-106-10)

REMOVAL

B230610621

Figure 1. Seatbelt Retractor.

1. Remove bolt (Figure 1, Item 2) securing seatbelt retractor (Figure 1, Item 1) to body and remove seatbelt retractor.

SEATBELT REMOVAL AND INSTALLATION - (CONTINUED)

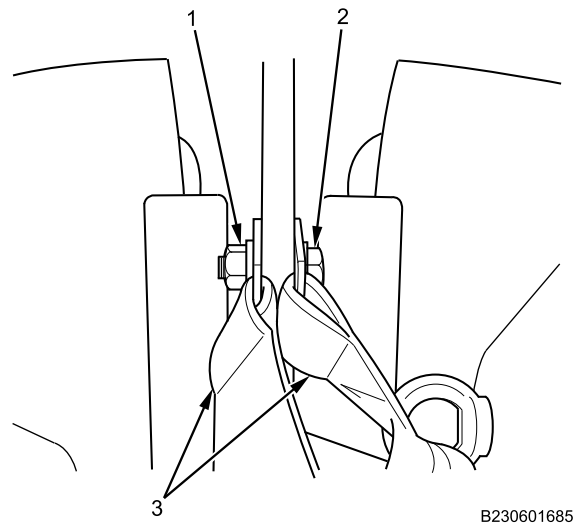

Figure 2. Seatbelt Buckle.

NOTE

Rear shown, front similar

2. Remove nut (Figure 2, Item 1) and bolt (Figure 2, Item 2) securing seatbelt buckle (Figure 2, Item 3) to floor anchor.

END OF TASK**INSTALLATION**

Figure 3. Seatbelt Retractor.

1. Position seatbelt retractor (Figure 3, Item 1) to body, install bolt (Figure 3, Item 2). Torque bolt to 25-30 lb-ft (34-41 N•m).

SEATBELT REMOVAL AND INSTALLATION - (CONTINUED)

Figure 4. Seatbelt Buckle.

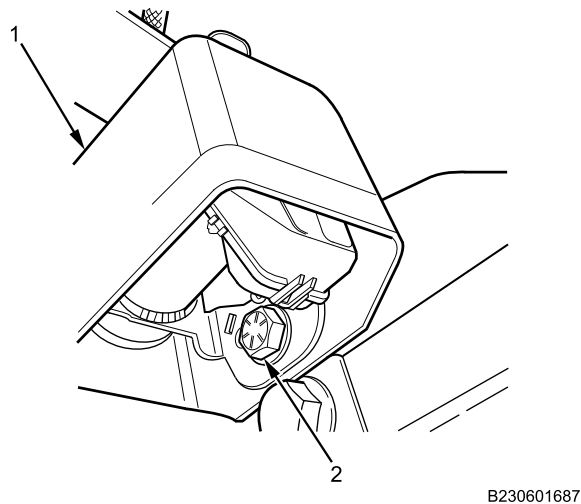
2. Position seatbelt buckle (Figure 4, Item 3) to floor anchor, install nut (Figure 4, Item 1) and bolt (Figure 4, Item 2). Torque bolt to 25-30 lb-ft (34-41 N•m).

END OF TASK**FOLLOW-ON MAINTENANCE**

1. Remove wheel chocks (TM 9-2355-106-10).

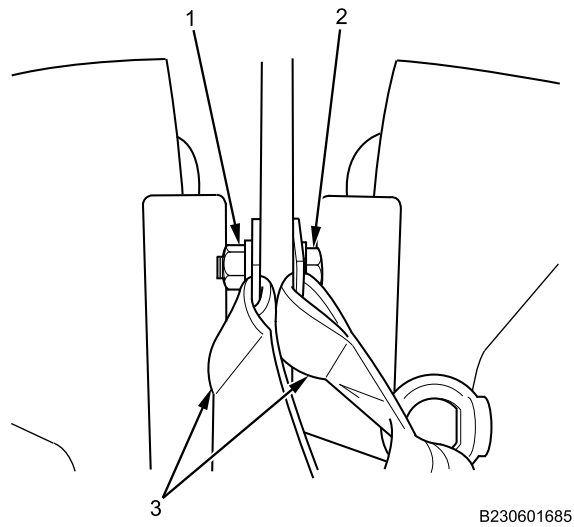
END OF TASK**END OF WORK PACKAGE**

FIELD MAINTENANCE

RIGHT FLOOR SEAT BRACKET REMOVAL AND INSTALLATION

INITIAL SETUP:

Tools and Special Tools

General Mechanic's Tool Kit (GMTK)
(WP 0795, Item 37)

References

TM 9-2355-106-10
TM 9-2355-106-23P
WP 0786
WP 0782

Equipment Condition

Parking brake set (TM 9-2355-106-10)

Transmission set in NEUTRAL (N) (TM 9-2355-106-10)
Engine off (TM 9-2355-106-10)
MAIN POWER switch off (TM 9-2355-106-10)
Wheels chocked (TM 9-2355-106-10)
Passenger seatbelt removed (WP 0664)
Passenger seat removed (WP 0666)

REMOVAL

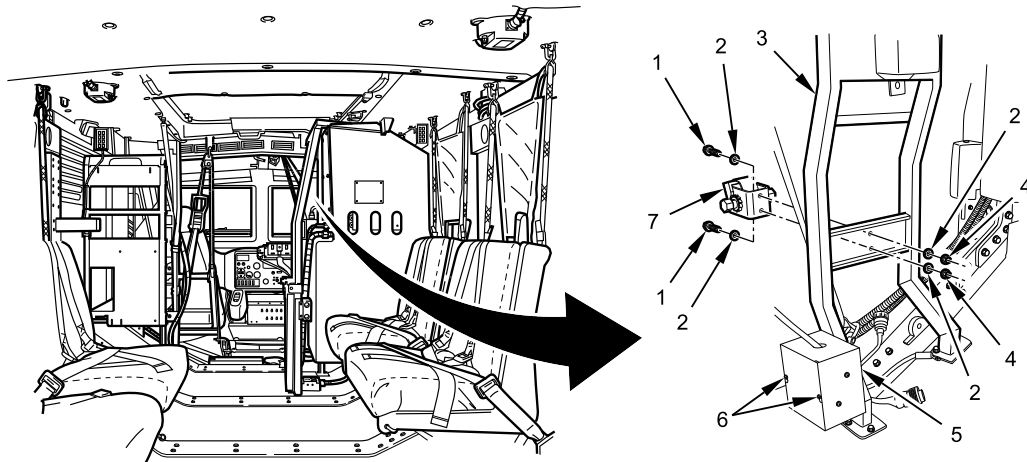

005398

Figure 1. Seatbelt Ratchet.

1. Remove two bolts (Figure 1, Item 1), four washers (Figure 1, Item 2), and two nuts (Figure 1, Item 4) securing seatbelt ratchet (Figure 1, Item 7) to floor seat bracket (Figure 1, Item 3).
2. Remove two screws (Figure 1, Item 6) and remove junction box access cover (Figure 1, Item 5).

RIGHT FLOOR SEAT BRACKET REMOVAL AND INSTALLATION - (CONTINUED)

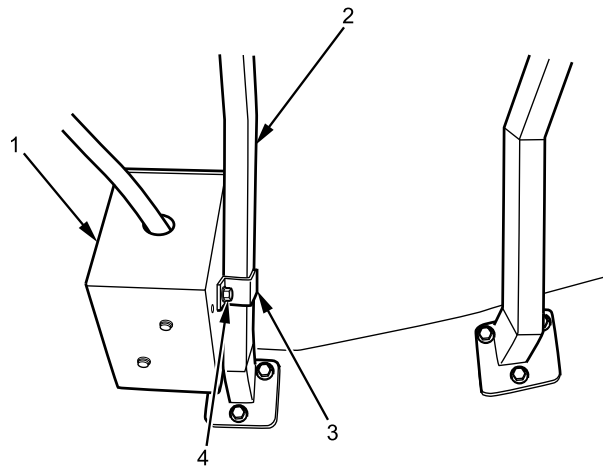

B231803675

Figure 2. Junction Box.

3. Remove two bolts, four washers, and two nuts (Figure 2, Item 4) and remove junction box bracket (Figure 2, Item 3) from junction box (Figure 2, Item 1).
4. Remove junction box (Figure 2, Item 1) from floor seat bracket (Figure 2, Item 2).

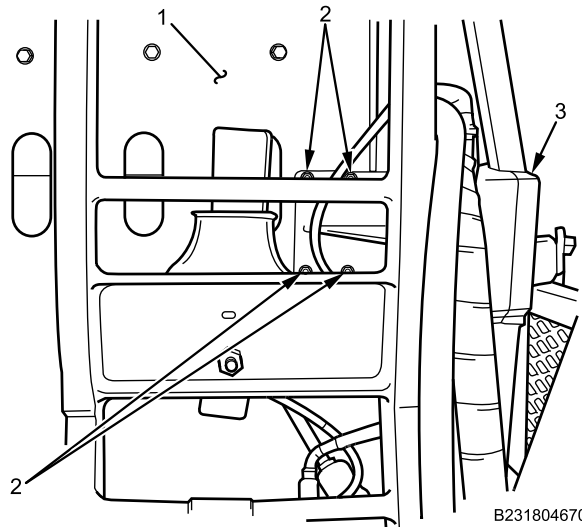

B231804670

Figure 3. HVAC Control Box.

5. Remove four hex socket-cap bolts, four washers (Figure 3, Item 2), and HVAC control box (Figure 3, Item 3) from HVAC box (Figure 3, Item 1).

RIGHT FLOOR SEAT BRACKET REMOVAL AND INSTALLATION - (CONTINUED)

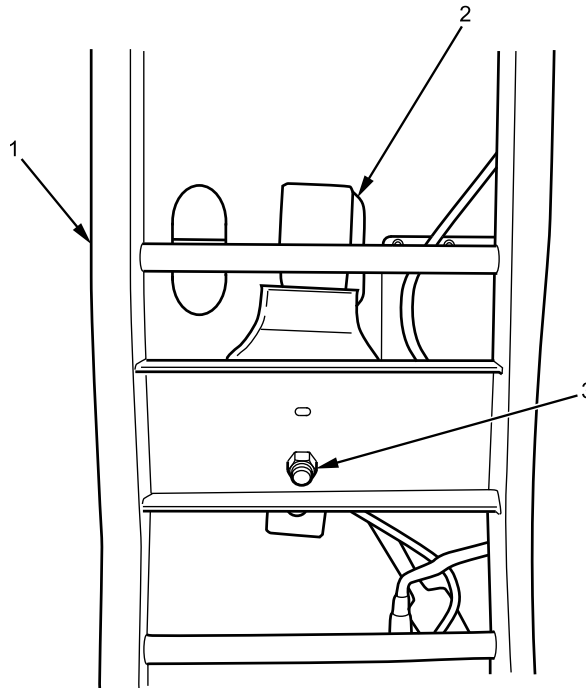

B231803676

Figure 4. Left Front Seatbelt Retractor.

6. Remove bolt, two washers, nut, bracket (Figure 4, Item 3), and right front seatbelt retractor (Figure 4, Item 2) from right front floor seat bracket (Figure 4, Item 1).

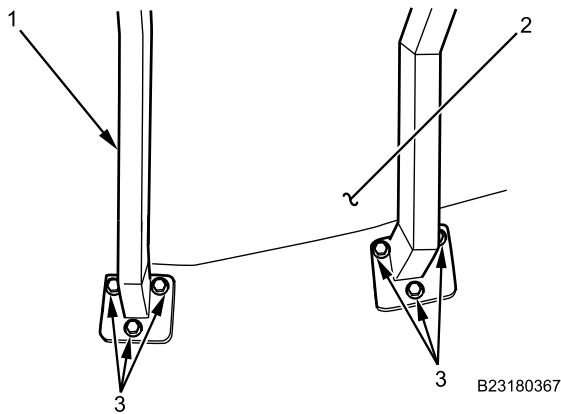

B231803677

Figure 5. Floor Seat Bracket Lower Mounting Bolts.

7. Remove six bolts and six washers (Figure 5, Item 3) securing floor seat bracket (Figure 5, Item 1) to vehicle floor (Figure 5, Item 2).

RIGHT FLOOR SEAT BRACKET REMOVAL AND INSTALLATION - (CONTINUED)

Figure 6. Floor Seat Bracket Upper Mounting Bolts.

8. Remove four bolts and four nuts (Figure 6, Item 2) securing floor seat bracket (Figure 6, Item 1) to vehicle overhead duct (Figure 6, Item 3). Remove floor seat bracket (Figure 6, Item 1).

END OF TASK**INSTALLATION**

Figure 7. Floor Seat Bracket Upper Mounting Bolts.

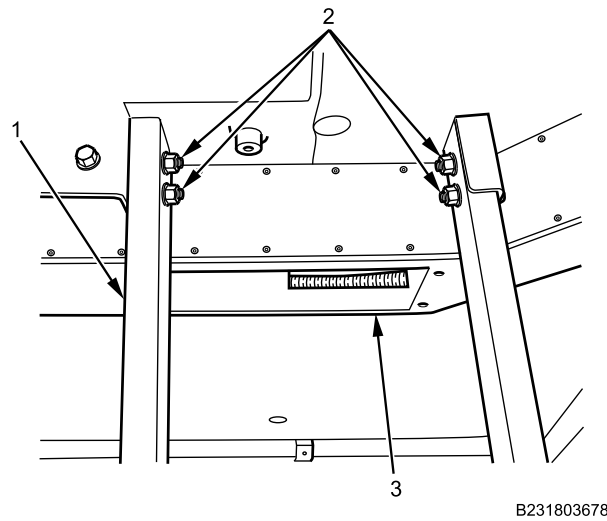
1. Install four bolts and four nuts (Figure 7, Item 2) to secure floor seat bracket (Figure 7, Item 1) to vehicle overhead duct (Figure 7, Item 3).

RIGHT FLOOR SEAT BRACKET REMOVAL AND INSTALLATION - (CONTINUED)

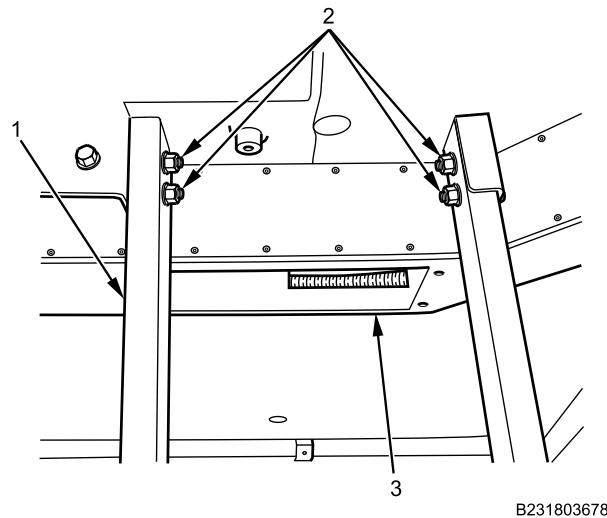
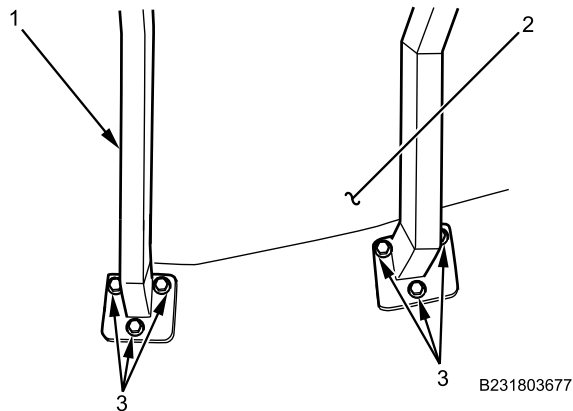

Figure 8. Floor Seat Bracket Lower Mounting Bolts.

2. Install six bolts and six washers (Figure 8, Item 3) to secure floor seat bracket (Figure 8, Item 1) to vehicle floor (Figure 8, Item 2).

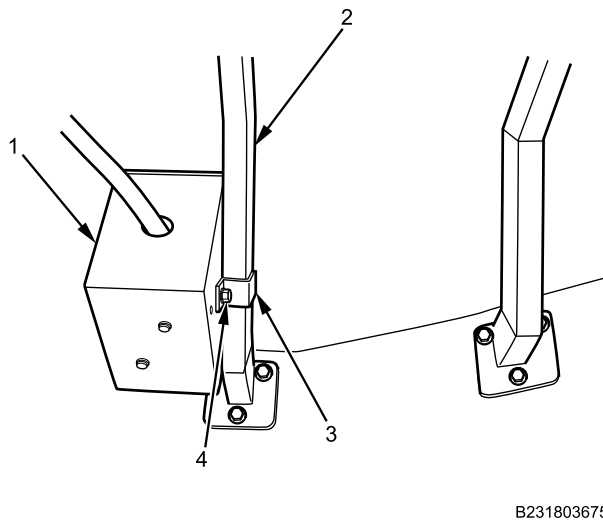

Figure 9. Junction Box Installation.

3. Install junction box (Figure 9, Item 1) on floor seat bracket (Figure 9, Item 2) with junction box bracket (Figure 9, Item 3) two bolts, four washers, and two nuts (Figure 9, Item 4).

RIGHT FLOOR SEAT BRACKET REMOVAL AND INSTALLATION - (CONTINUED)

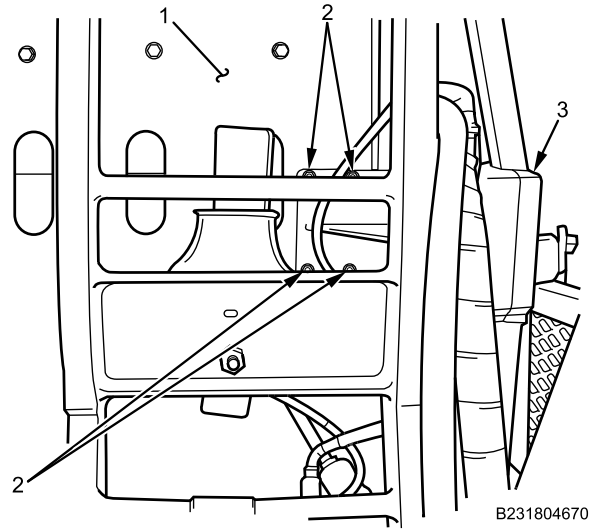

Figure 10. HVAC Control Box

4. Install HVAC control box (Figure 10, Item 3) on HVAC box (Figure 10, Item 1) with four hex socket-cap bolts and four washers (Figure 10, Item 2).

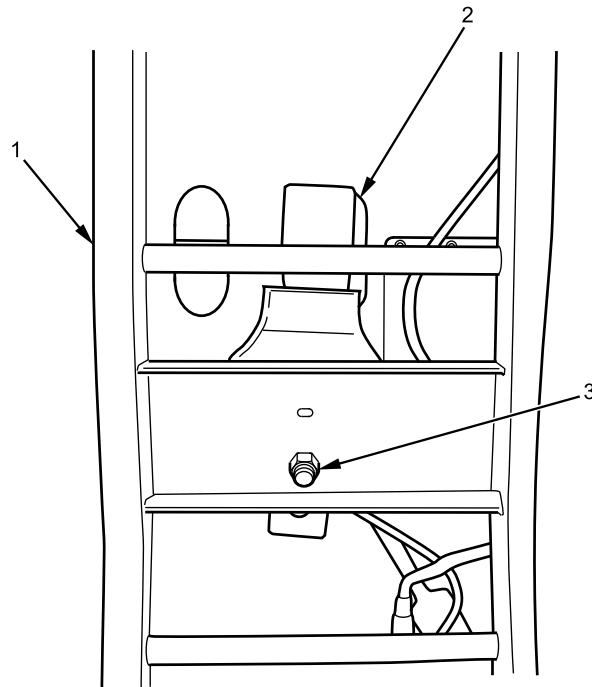
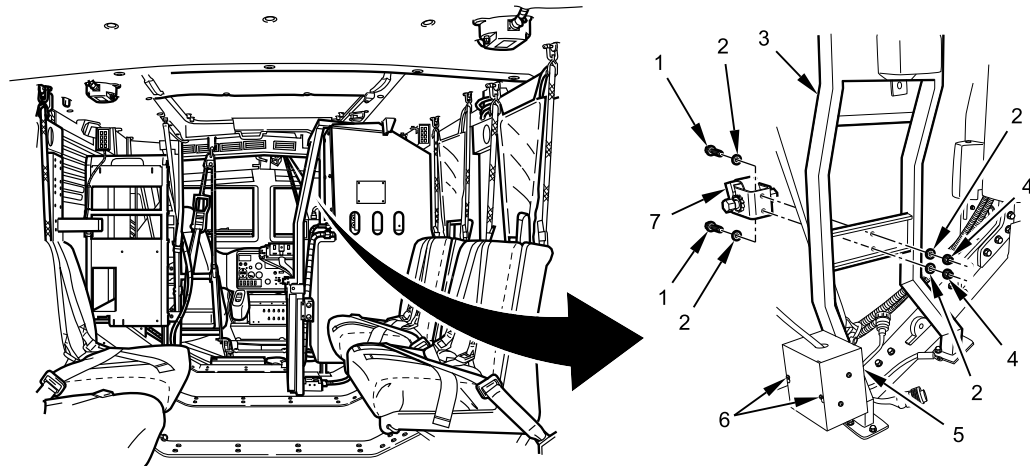

Figure 11. Left Front Seatbelt Retractor.

5. Install bolt, two washers, bracket, nut (Figure 11, Item 3), and left front seatbelt retractor (Figure 11, Item 2) on floor seat bracket (Figure 11, Item 1).

RIGHT FLOOR SEAT BRACKET REMOVAL AND INSTALLATION - (CONTINUED)

005398

Figure 12. Seatbelt Ratchet Installation.

6. Install access cover to junction box (Figure 12, Item 5) with two screws (Figure 12, Item 6).
7. Install seatbelt ratchet (Figure 12, Item 7) onto floor seat bracket (Figure 12, Item 3) with two bolts (Figure 12, Item 1), four washers (Figure 12, Item 2), and two nuts (Figure 12, Item 4).

END OF TASK**FOLLOW-ON MAINTENANCE**

1. Install passenger seat (WP 0666).
2. Install passenger seatbelt (WP 0664).
3. Remove wheel chocks (TM 9-2355-106-10).

END OF TASK**END OF WORK PACKAGE**

FIELD MAINTENANCE

CREW AND FRONT PASSENGER SEAT REMOVAL AND INSTALLATION

INITIAL SETUP:

Tools and Special Tools

General Mechanic's Tool Kit (GMTK)
(WP 0795, Item 37)

References

TM 9-2355-106-10
TM 9-2355-106-23P
WP 0786
WP 0782

Equipment Condition

Parking brake set (TM 9-2355-106-10)
Transmission set in NEUTRAL (N) (TM
9-2355-106-10)
Engine off (TM 9-2355-106-10)
MAIN POWER switch off (TM 9-2355-106-10)
Wheels chocked (TM 9-2355-106-10)

REMOVAL

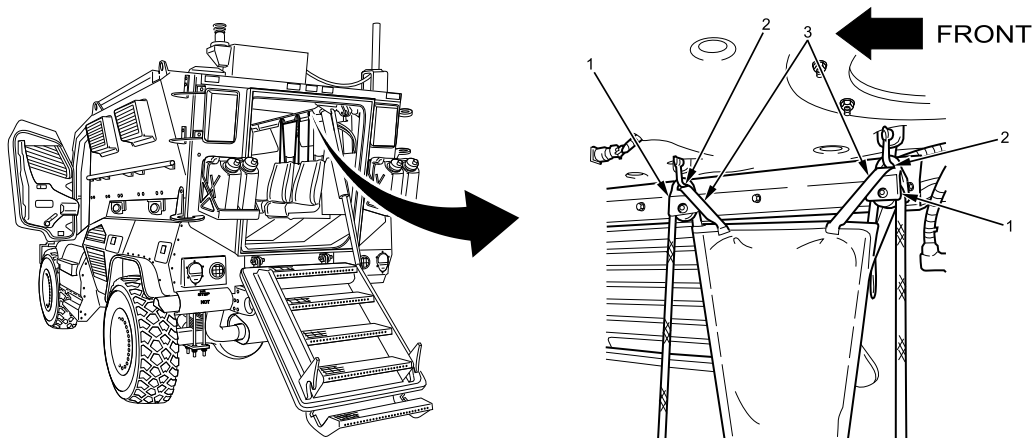

B231810854

Figure 1. Headrest Strap.

1. Pull strap (Figure 1, Item 1) from hook-and-loop material (Figure 1, Item 3) and pull through hole (Figure 1, Item 2) in seat support on both sides.

CREW AND FRONT PASSENGER SEAT REMOVAL AND INSTALLATION - (CONTINUED)

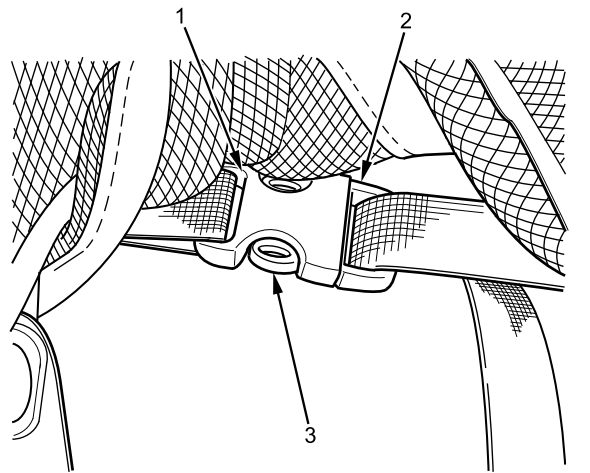

B230601677

Figure 2. Headrest Buckle.

2. Push in on buckle release buttons (Figure 2, Item 3) to disengage headrest buckles (Figure 2, Item 1 and 2).

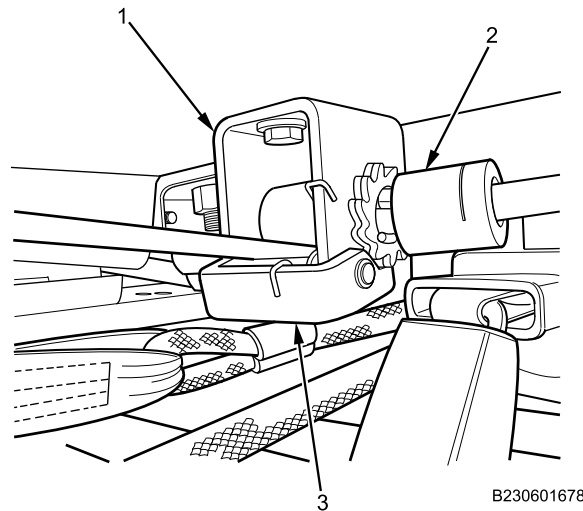

B230601678

Figure 3. Rear Seat Hanger Safety Strap.

3. Release tension on rear seat hanger safety strap (Figure 3, Item 1) by turning nut with socket (Figure 3, Item 2). Hold release latch (Figure 3, Item 3) while loosening strap.

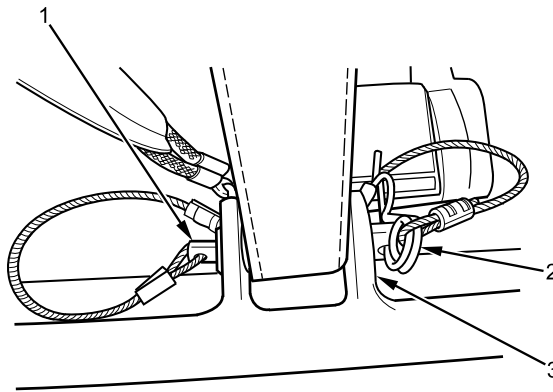
CREW AND FRONT PASSENGER SEAT REMOVAL AND INSTALLATION - (CONTINUED)

B230601683

Figure 4. Seat Upper Strap.

4. Pull clevis pin (Figure 4, Item 2) from seat strap mount pin (Figure 4, Item 1) at top rear of seat (Figure 4, Item 3).

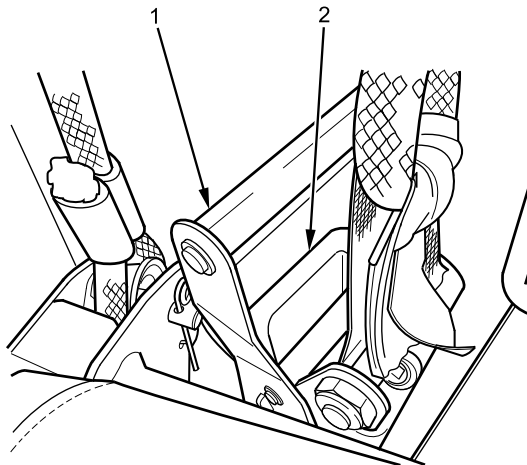

B230601679

Figure 5. Suspension Lever.

5. Place hand on lever (Figure 5, Item 1), lift up on latch (Figure 5, Item 2), and swing handle down.

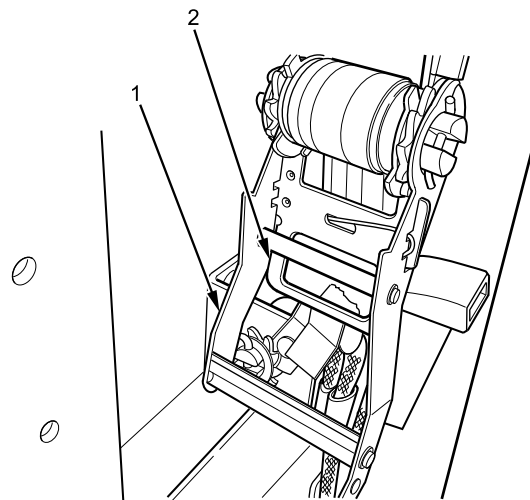
CREW AND FRONT PASSENGER SEAT REMOVAL AND INSTALLATION - (CONTINUED)

B230601682

Figure 6. Seat Suspension Lever Release.

6. With handle (Figure 6, Item 1) in down position, pull down on release lever (Figure 6, Item 2) to release tension on seat suspension.

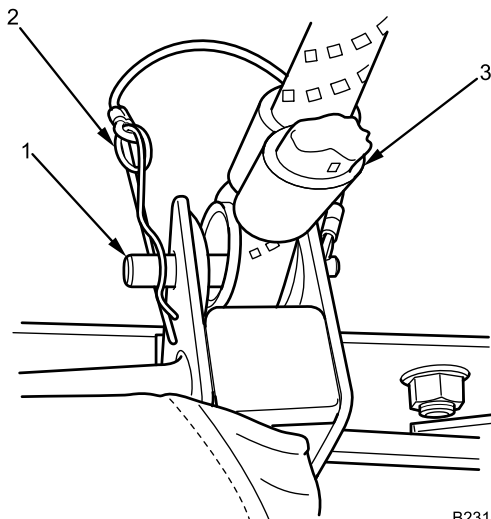

B231801960

Figure 7. Seat Suspension Retainer.

7. Remove clevis pin (Figure 7, Item 2) and pull pin (Figure 7, Item 1) from seat suspension (Figure 7, Item 3).

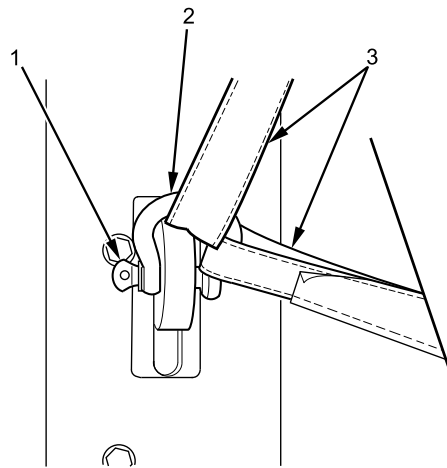
CREW AND FRONT PASSENGER SEAT REMOVAL AND INSTALLATION - (CONTINUED)

B230601684

Figure 8. Floor Anchor.

8. Remove outboard floor anchor pin (Figure 8, Item 1) from floor anchor (Figure 8, Item 2) and remove straps (Figure 8, Item 3).

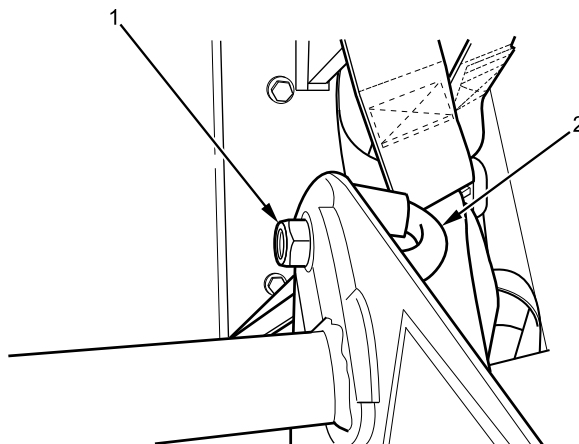

B230601688

Figure 9. Inboard Eyebolt.

9. Remove rear inboard strap eyebolt (Figure 9, Item 2) and nut (Figure 9, Item 1) from seat.

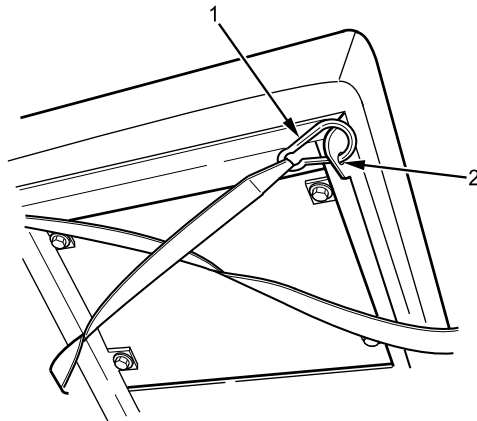
CREW AND FRONT PASSENGER SEAT REMOVAL AND INSTALLATION - (CONTINUED)

B23060181

Figure 10. Floor Straps.

10. Remove floor straps (Figure 10, Item 1) from seat bottom (Figure 10, Item 2) and remove seat.

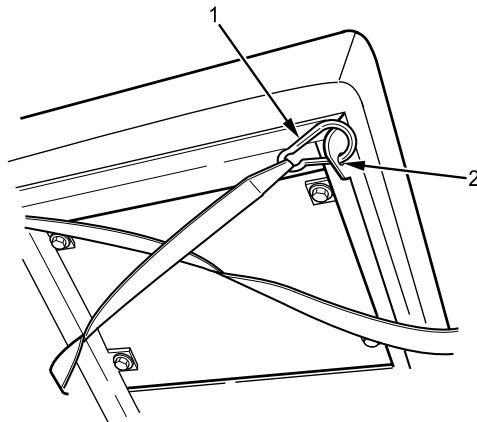
END OF TASK**INSTALLATION**

B23060181

Figure 11. Floor Straps.

1. Connect floor straps (Figure 11, Item 1) to seat bottom (Figure 11, Item 2).

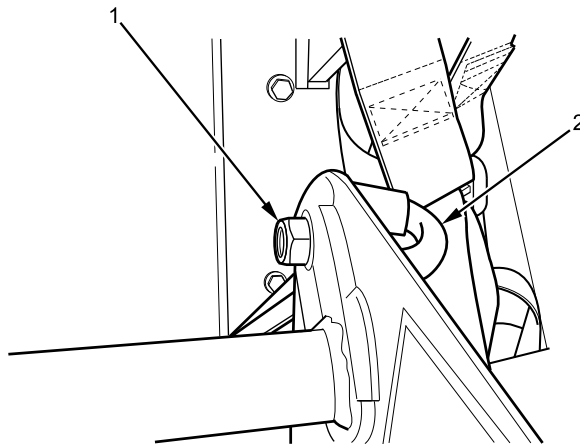
CREW AND FRONT PASSENGER SEAT REMOVAL AND INSTALLATION - (CONTINUED)

B230601688

Figure 12. Inboard Eyebolt.

2. Install rear inboard strap eyebolt (Figure 12, Item 2) and nut (Figure 12, Item 1) on seat and tighten securely.

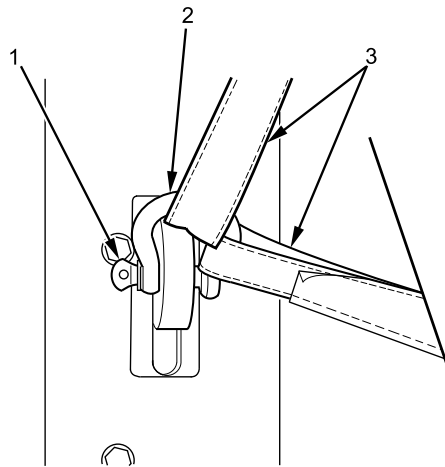

B230601684

Figure 13. Floor Anchor.

3. Position straps (Figure 13, Item 3) on floor anchor (Figure 13, Item 2) and install outboard floor anchor pin (Figure 13, Item 1).

CREW AND FRONT PASSENGER SEAT REMOVAL AND INSTALLATION - (CONTINUED)

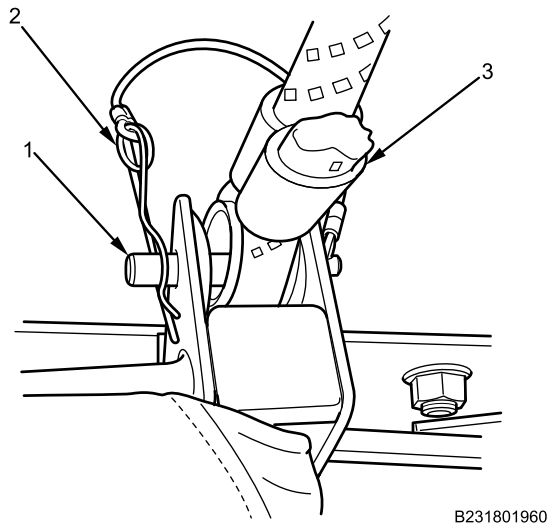

Figure 14. Seat Suspension Retainer.

4. Install pin (Figure 14, Item 1) through seat suspension mount (Figure 14, Item 3) and insert clevis pin (Figure 14, Item 2) to secure.

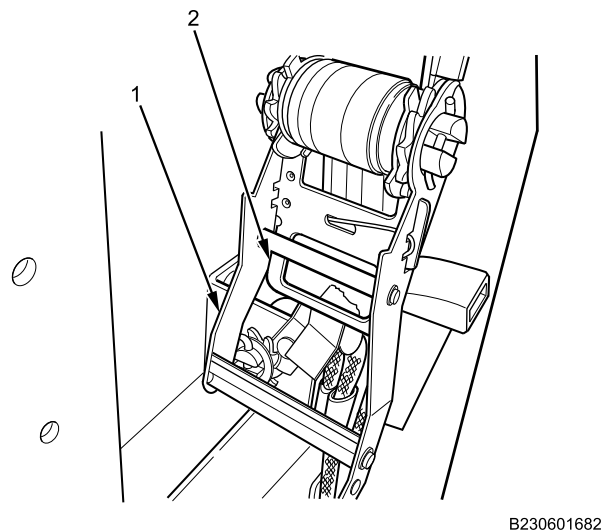
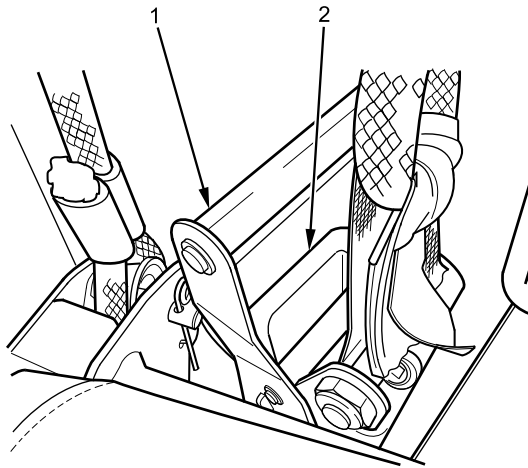

Figure 15. Seat Suspension Lever Release.

5. Ensure handle (Figure 15, Item 1) is in down position and pull on strap to remove slack.
6. Pull down on release latch (Figure 15, Item 2) and lift up on handle to begin ratcheting seat suspension handle until rope is tight.

CREW AND FRONT PASSENGER SEAT REMOVAL AND INSTALLATION - (CONTINUED)



B230601679

Figure 16. Suspension Lever.

7. Place handle (Figure 16, Item 1) in up position when rope is tightened and ensure latch (Figure 16, Item 2) is engaged in the down position.

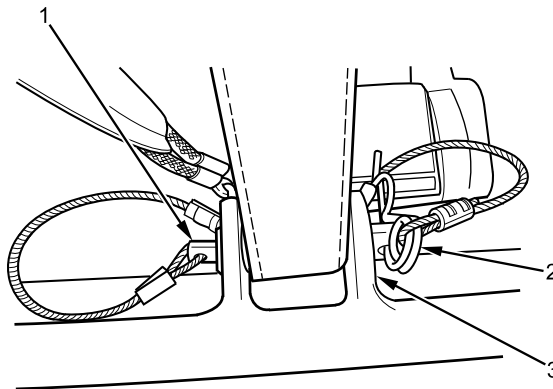

B230601683

Figure 17. Seat Upper Strap.

8. Position upper seat strap to seat bracket (Figure 17, Item 3).
9. Insert pin (Figure 17, Item 1) and clevis pin (Figure 17, Item 2).

CREW AND FRONT PASSENGER SEAT REMOVAL AND INSTALLATION - (CONTINUED)

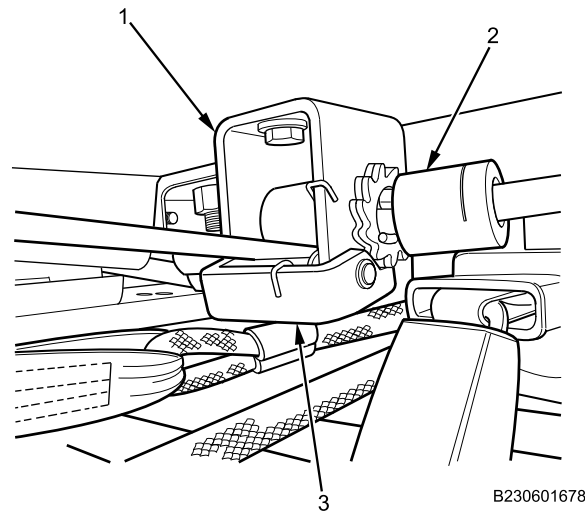

Figure 18. Rear Seat Hanger Safety Strap.

10. Use socket (Figure 18, Item 2) to turn rear seat hanger safety strap (Figure 18, Item 1) until tight. Ensure latch (Figure 18, Item 3) is engaged.

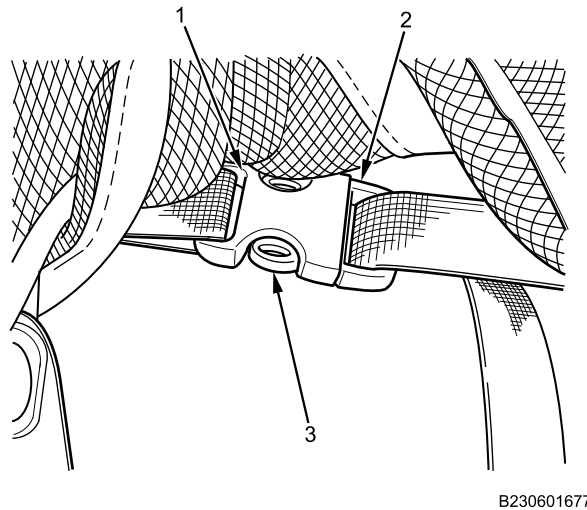

Figure 19. Headrest Buckle.

11. Position headrest around seat suspension rope.
12. Push headrest buckles (Figure 19, Item 1 and 2) together until locks (Figure 19, Item 3) are engaged.

CREW AND FRONT PASSENGER SEAT REMOVAL AND INSTALLATION - (CONTINUED)

Figure 20. Headrest Strap.

13. Feed strap (Figure 20, Item 1) through hole (Figure 20, Item 2) in seat suspension pulley, pull down until tight, and push against hook-and-loop material (Figure 20, Item 3) to secure.

END OF TASK

FOLLOW-ON MAINTENANCE

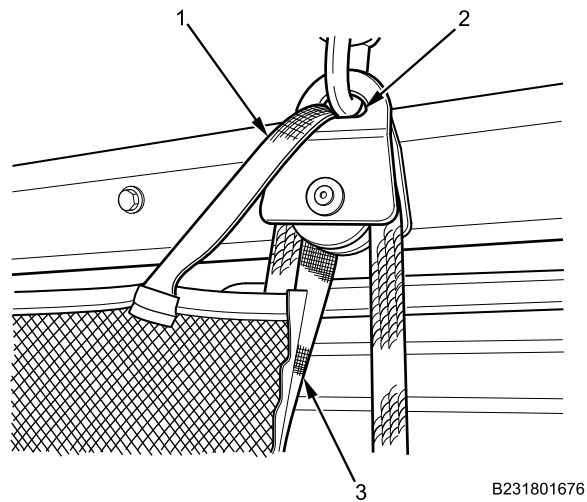
1. Remove wheel chocks (TM 9-2355-106-10).

END OF TASK

END OF WORK PACKAGE

FIELD MAINTENANCE

COMMUNICATIONS RACK REMOVAL AND INSTALLATION

INITIAL SETUP:

Tools and Special Tools

General Mechanic's Tool Kit (GMTK)
(WP 0795, Item 37)

TM 9-2355-106-23P

WP 0786

WP 0782

Materials/Parts

Lockwasher - (34) (WP 0796, Item 23)
Cable lock strap (WP 0796, Item 120)

Equipment Condition

Parking brake set (TM 9-2355-106-10)

Transmission set in NEUTRAL (N) (TM
9-2355-106-10)

Engine off (TM 9-2355-106-10)

MAIN POWER switch off (TM 9-2355-106-10)

Wheels chocked (TM 9-2355-106-10)

Fire suppression system (FSS) cabin cylinder
removed (WP 0745)

Personnel Required

Maintainer - (2)

References

TM 9-2355-106-10

REMOVAL

NOTE

Note location of cable lock straps during removal to aid installation.

1. Turn left front seat hanger safety strap tensioner wheel (Figure 1, Item 4) clockwise to disengage release lever (Figure 1, Item 3) and allow slack in safety strap (Figure 1, Item 2).

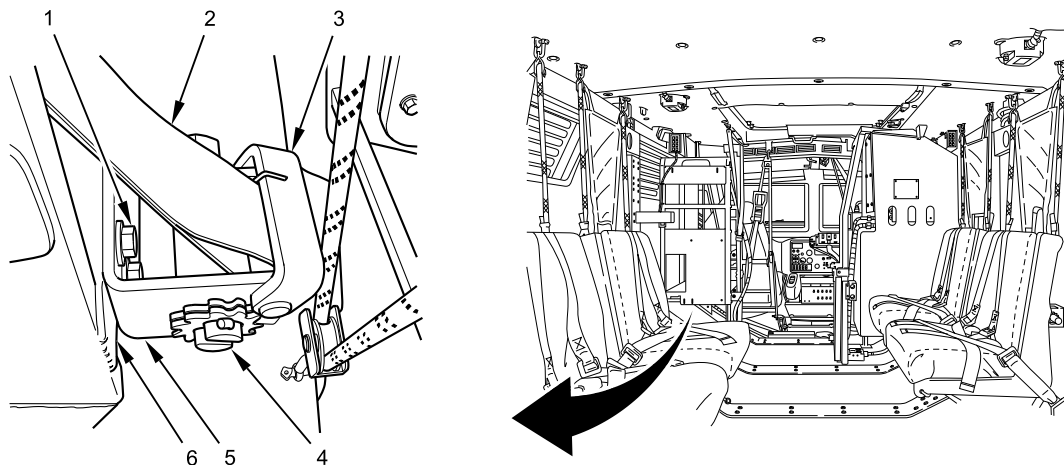

B231810571

Figure 1. Left Front Seat Hanger Safety Strap Tensioner.

2. Remove two bolts (Figure 1, Item 1), flat washers, and nuts from left front seat hanger safety strap tensioner (Figure 1, Item 5).
3. Remove left front seat hanger safety strap tensioner (Figure 1, Item 5) from left front floor seat bracket (Figure 1, Item 6).

COMMUNICATIONS RACK REMOVAL AND INSTALLATION - (CONTINUED)

4. Remove anchor pin retainer (Figure 2, Item 1) from anchor pin (Figure 2, Item 3).

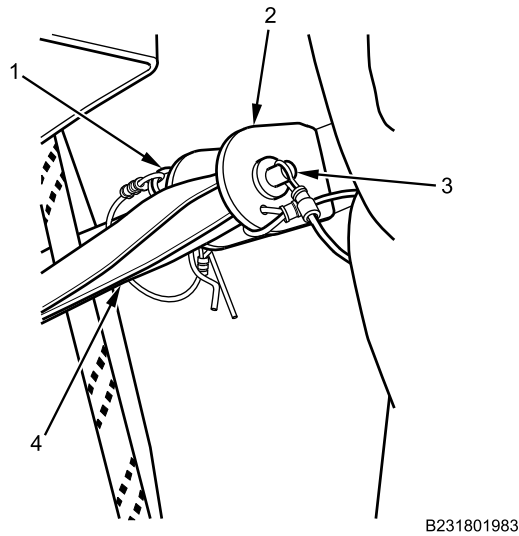

Figure 2. Left Front Seat Hanger Safety Strap Anchor Pin.

5. Remove anchor pin (Figure 2, Item 3) from seat bracket (Figure 2, Item 2) and left front seat hanger safety strap (Figure 2, Item 4).
6. Remove bolt (Figure 3, Item 3) and nut from left front seat belt retractor (Figure 3, Item 1).

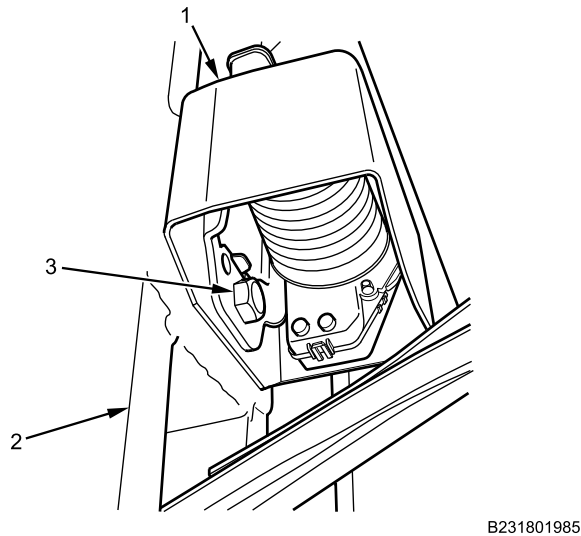
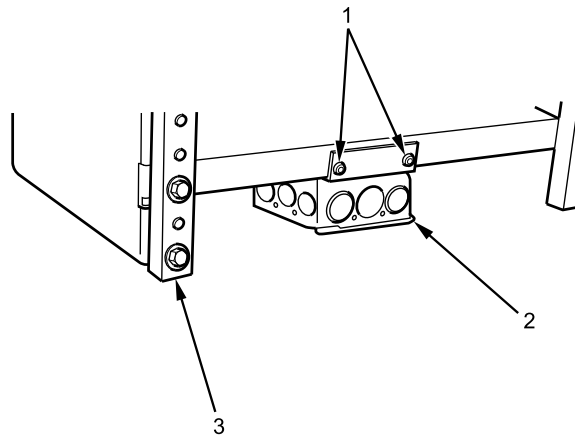

Figure 3. Left Front Seat Belt Retractor.

7. Remove left front seat belt retractor (Figure 3, Item 1) from left front floor seat bracket (Figure 3, Item 2).

COMMUNICATIONS RACK REMOVAL AND INSTALLATION - (CONTINUED)

8. Remove two screws (Figure 4, Item 1) from left 12V DC socket (Figure 4, Item 2).



B231801988

Figure 4. Left 12V DC Socket.

9. Remove 12V DC socket (Figure 4, Item 2) from communications rack (Figure 4, Item 3).
10. Loosen two bolts (Figure 5, Item 4) on top lower brackets (Figure 5, Item 3).

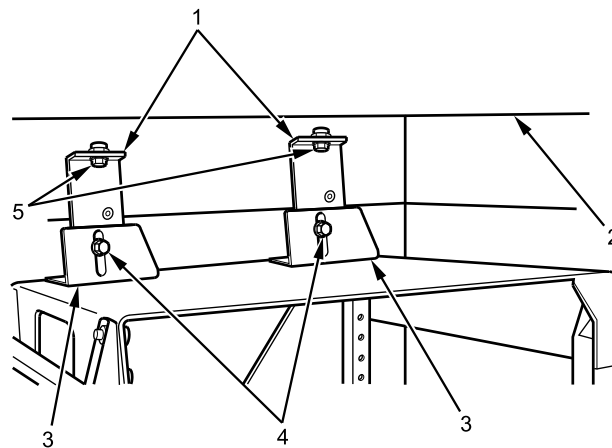

B231801987

Figure 5. Communications Rack Top Brackets.

11. Remove two bolts (Figure 5, Item 5) from top upper brackets (Figure 5, Item 1).
12. Move top upper brackets (Figure 5, Item 1) away from roof headliner (Figure 5, Item 2).

COMMUNICATIONS RACK REMOVAL AND INSTALLATION - (CONTINUED)

13. Remove two nuts (Figure 6, Item 2) and bolts attaching front and rear ground straps (Figure 6, Item 1) on floor brackets (Figure 6, Item 3).

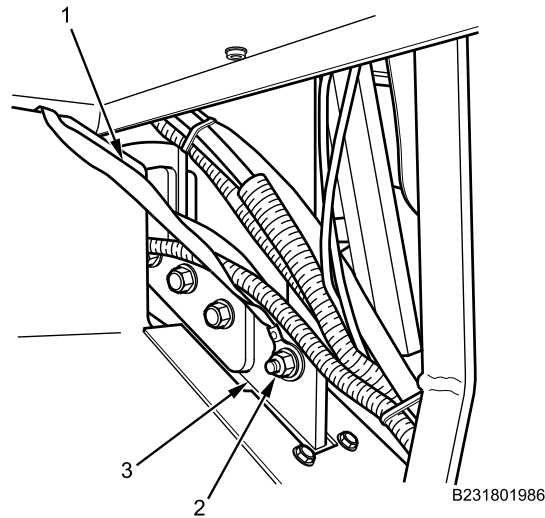

Figure 6. Ground Straps. Front Ground Strap Shown. Rear Ground Strap Similar.

14. Remove ground straps (Figure 6, Item 1) from floor brackets (Figure 6, Item 3).

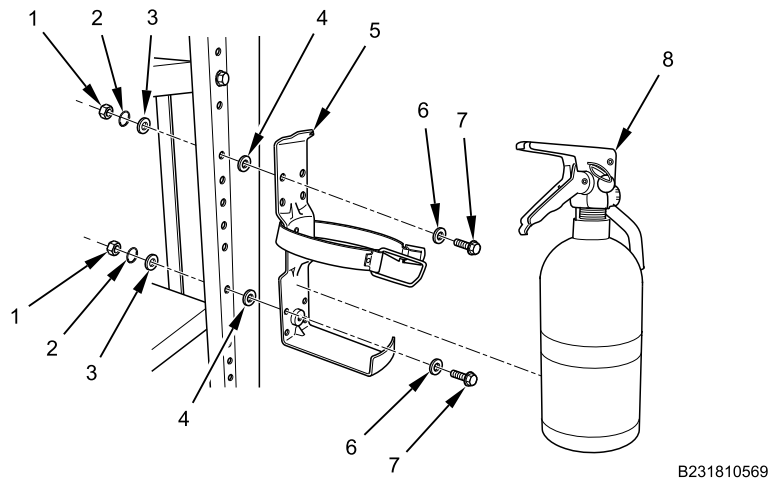

Figure 7. Fire Extinguisher and Bracket.

15. Remove fire extinguisher (Figure 7, Item 8) from fire extinguisher bracket (Figure 7, Item 5).
16. Remove two bolts (Figure 7, Item 7), spacers (Figure 7, Item 4 and 6), fire extinguisher bracket (Figure 7, Item 5), washers (Figure 7, Item 3), lockwashers (Figure 7, Item 2), and nuts (Figure 7, Item 1) from communication rack. Discard lockwashers.

COMMUNICATIONS RACK REMOVAL AND INSTALLATION - (CONTINUED)**WARNING**

Ensure communications rack does not fall when removing fasteners. Use assistance from an assistant to support rack while fasteners are removed. Failure to comply may result in damage to equipment and serious injury to personnel.

17. With assistant, support communications rack (Figure 8, Item 1) and remove two bolts (Figure 8, Item 4), nuts, and flat washers from left front floor seat bracket (Figure 8, Item 3).

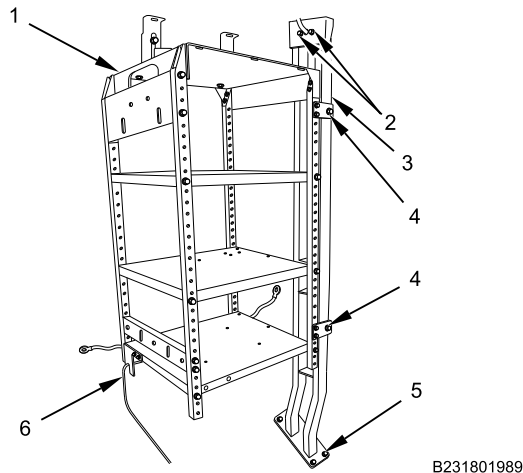

Figure 8. Communications Rack and Left Front Floor Seat Bracket.

18. With assistant, disengage communications rack (Figure 8, Item 1) from floor plate (Figure 8, Item 6) and remove communications rack.
19. Remove four bolts (Figure 8, Item 5) and flat washers from bottom of left front floor seat bracket (Figure 8, Item 3).
20. Remove two bolts (Figure 8, Item 2) and flat washers from top of left front floor seat bracket (Figure 8, Item 3) and remove bracket.

END OF TASK

COMMUNICATIONS RACK REMOVAL AND INSTALLATION - (CONTINUED)**DISASSEMBLY**

1. Remove two bolts (Figure 9, Item 4) and nuts from top upper brackets (Figure 9, Item 5) and remove upper brackets. One bolt shown. One bolt hidden from view.

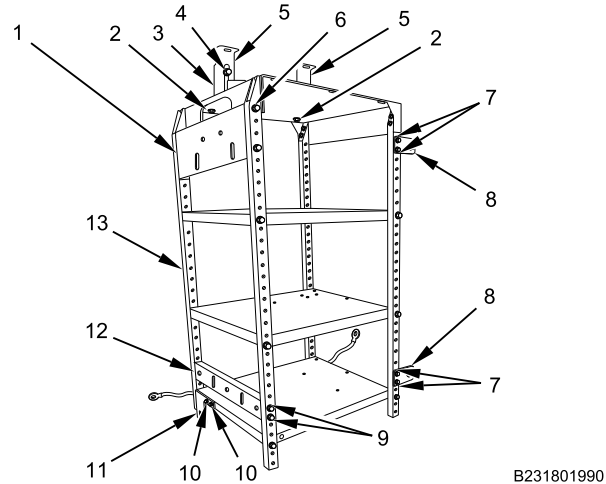

Figure 9. Communications Rack Brackets.

2. Remove two nuts (Figure 9, Item 2) and bolts from top lower brackets (Figure 9, Item 3), and remove lower brackets from communications rack (Figure 9, Item 13). Rear top lower bracket shown. Front top lower bracket hidden from view.
3. Remove four bolts (Figure 9, Item 6), nuts, and eight flat washers from upper side bracket (Figure 9, Item 1), and remove upper side bracket from communications rack (Figure 9, Item 13). Two bolts shown. Two bolts hidden from view.
4. Remove four bolts (Figure 9, Item 9), nuts, and eight flat washers from power box bracket (Figure 9, Item 12), and remove bracket from communications rack (Figure 9, Item 13). Two bolts shown. Two bolts hidden from view.
5. Remove four bolts (Figure 9, Item 7), nuts, and flat washers from side mounting brackets (Figure 9, Item 8), and remove brackets from communications rack (Figure 9, Item 13).
6. Remove two screws (Figure 9, Item 10) from bottom alignment bracket (Figure 9, Item 11), and remove bracket from communications rack (Figure 9, Item 13).

COMMUNICATIONS RACK REMOVAL AND INSTALLATION - (CONTINUED)

7. Remove eight bolts, nuts (Figure 10, Item 2 and 3), lockwashers, and 16 flat washers from top shelf (Figure 10, Item 1), and remove top shelf from communications rack (Figure 10, Item 7). Some fasteners hidden from view. Discard lockwashers.

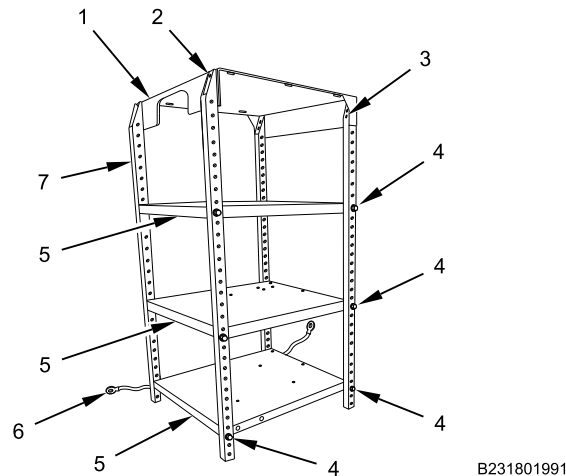

Figure 10. Communications Rack.

8. Remove 12 bolts (Figure 10, Item 4), nuts, flat washers, and 24 lockwashers from communications rack (Figure 10, Item 7). Six bolts shown. Six bolts hidden from view. Discard lockwashers.
9. Remove three shelves (Figure 10, Item 5) and two ground straps (Figure 10, Item 6) from communications rack (Figure 10, Item 7).

END OF TASK

COMMUNICATIONS RACK REMOVAL AND INSTALLATION - (CONTINUED)

ASSEMBLY

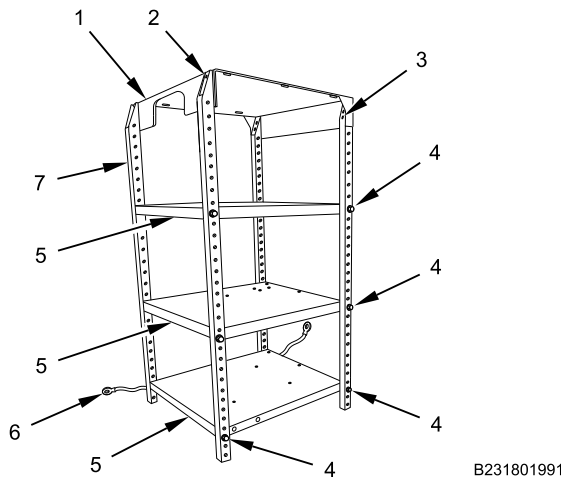

Figure 11. Communications Rack.

1. Install three shelves (Figure 11, Item 5) and two ground straps (Figure 11, Item 6) on communications rack (Figure 11, Item 7) with 12 bolts (Figure 11, Item 4), nuts, flat washers, and 24 new lockwashers . Do not tighten. Six bolts shown. Six bolts hidden from view.
2. Install top shelf (Figure 11, Item 1) with eight bolts, nuts (Figure 11, Item 2 and 3), new lockwashers, and 16 flat washers. Do not tighten. Some fasteners hidden from view.
3. Square communications rack (Figure 11, Item 7) and tighten 20 bolts and nuts (Figure 11, Item 2, 3, and 4) securely. Some fasteners hidden from view.
4. Install bottom alignment bracket (Figure 12, Item 11) on communications rack (Figure 12, Item 13) with two screws (Figure 12, Item 10) and tighten securely.

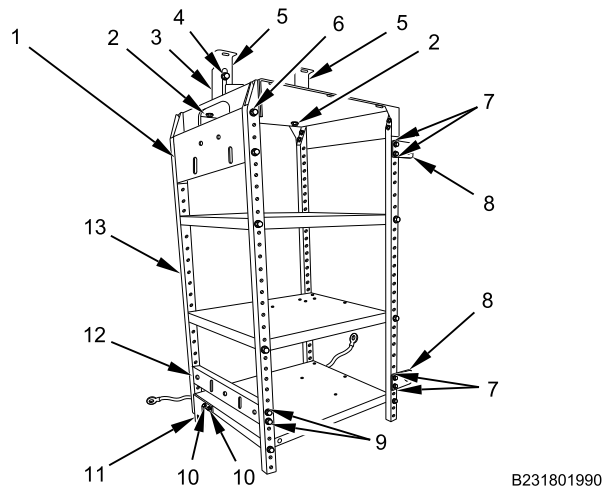

Figure 12. Communications Rack Brackets.

5. Install two side mounting brackets (Figure 12, Item 8) on communications rack (Figure 12, Item 13) with four bolts (Figure 12, Item 7), nuts, and flat washers and tighten securely.
6. Install power box bracket (Figure 12, Item 12) on communications rack (Figure 12, Item 13) with four bolts (Figure 12, Item 9), nuts, and eight flat washers and tighten securely. Two bolts shown. Two bolts hidden from view.

COMMUNICATIONS RACK REMOVAL AND INSTALLATION - (CONTINUED)

7. Install upper side bracket (Figure 12, Item 1) on communications rack (Figure 12, Item 13) with four bolts (Figure 12, Item 6), nuts, and eight flat washers and tighten securely. Two bolts shown. Two bolts hidden from view.
8. Install top lower brackets (Figure 12, Item 3) on communications rack (Figure 12, Item 13) with two nuts (Figure 12, Item 2) and bolts. Do not tighten. Rear top lower bracket shown. Front top lower bracket hidden.
9. Install top upper brackets (Figure 12, Item 5) on top lower brackets (Figure 12, Item 3) with two bolts (Figure 12, Item 4) and nuts. Do not tighten.

END OF TASK**INSTALLATION**

1. Install top of left front floor seat bracket (Figure 13, Item 3) with two bolts (Figure 13, Item 2) and nuts. Do not tighten.

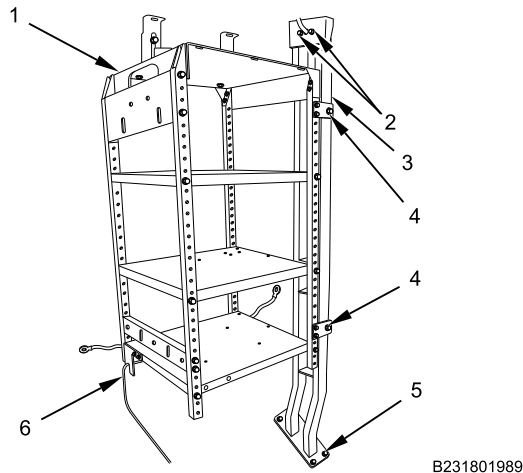

Figure 13. Communications Rack and Left Front Floor Seat Bracket.

2. Install bottom of left front floor seat bracket (Figure 13, Item 3) with four bolts (Figure 13, Item 5) and flat washers and tighten securely.
3. Tighten two bolts (Figure 13, Item 2) securely.
4. With assistant, install communications rack (Figure 13, Item 1) with bottom bracket engaged on floor plate (Figure 13, Item 6).
5. Install two bolts (Figure 13, Item 4) on left front floor seat bracket (Figure 13, Item 3) and tighten securely.

COMMUNICATIONS RACK REMOVAL AND INSTALLATION - (CONTINUED)

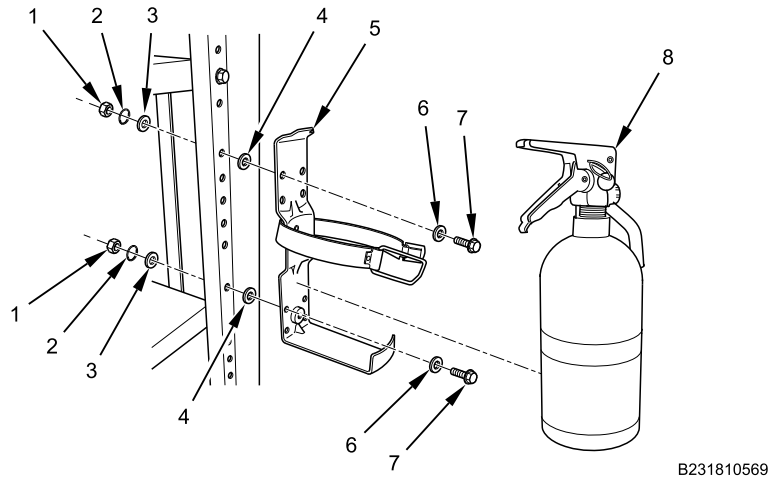

Figure 14. Fire Extinguisher and Bracket.

6. Install fire extinguisher bracket (Figure 14, Item 5) on communication rack with two bolts (Figure 14, Item 7), spacers (Figure 14, Item 4 and 6), washers (Figure 14, Item 3), new lockwashers (Figure 14, Item 2), and nuts (Figure 14, Item 1).
7. Install fire extinguisher (Figure 14, Item 8) in fire extinguisher bracket (Figure 14, Item 5) and secure.
8. Install two bolts (Figure 15, Item 5) on top upper brackets (Figure 15, Item 1) and tighten securely.

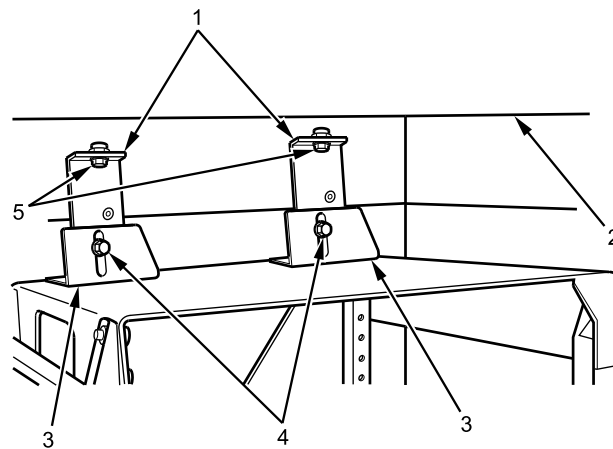

Figure 15. Communications Rack Top Brackets.

9. Tighten two bolts (Figure 15, Item 4) and nuts on top lower brackets (Figure 15, Item 3) securely.

COMMUNICATIONS RACK REMOVAL AND INSTALLATION - (CONTINUED)

Figure 16. Ground Straps. Front Ground Strap Shown. Rear Ground Strap Similar.

10. Install ground straps (Figure 16, Item 1) on floor brackets (Figure 16, Item 3) with two nuts (Figure 16, Item 2) and bolts and tighten securely.
11. Install left 12V DC socket (Figure 17, Item 2) on communications rack (Figure 17, Item 3) with two screws (Figure 17, Item 1) and tighten securely.

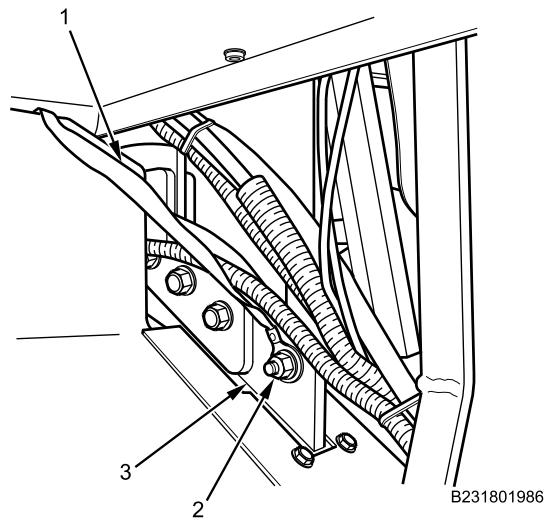
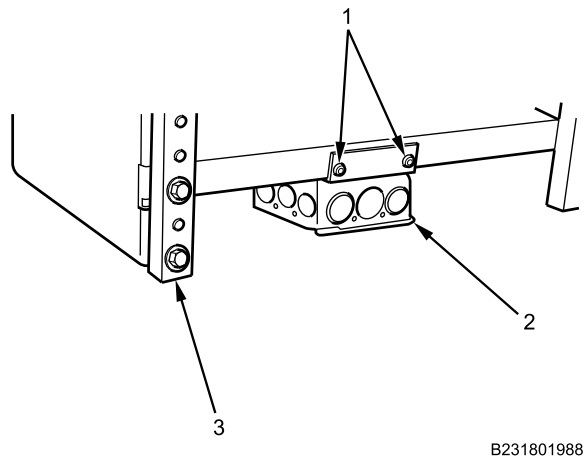
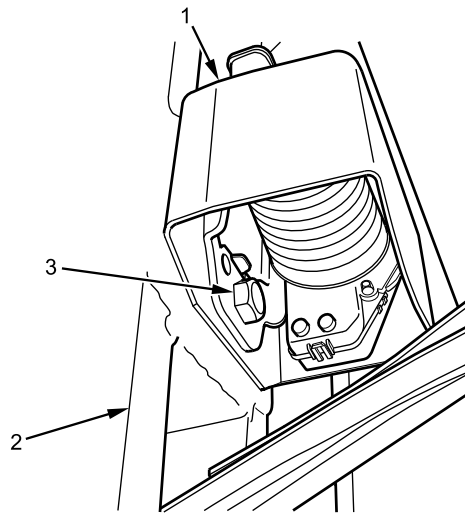

Figure 17. Left 12V DC Socket.

COMMUNICATIONS RACK REMOVAL AND INSTALLATION - (CONTINUED)



B231801985

Figure 18. Left Front Seat Belt Retractor.

12. Install left front seat belt retractor (Figure 18, Item 1) on left front floor seat bracket (Figure 18, Item 2) with bolt (Figure 18, Item 3) and nut and tighten securely.

WARNING

Ensure seat hanger safety strap is not twisted. Twisted seat hanger safety strap could weaken and break when under stress. Failure to comply may result in serious injury or death to personnel.

13. Route seat hanger safety strap (Figure 19, Item 1) through lower rung (Figure 19, Item 2) on left front floor seat bracket (Figure 19, Item 3).

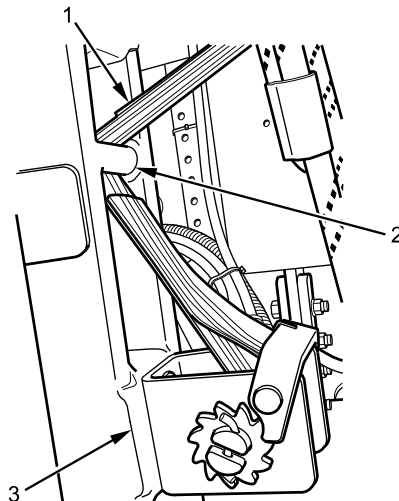

B231801984

Figure 19. Seat Hanger Safety Strap Routing.

COMMUNICATIONS RACK REMOVAL AND INSTALLATION - (CONTINUED)

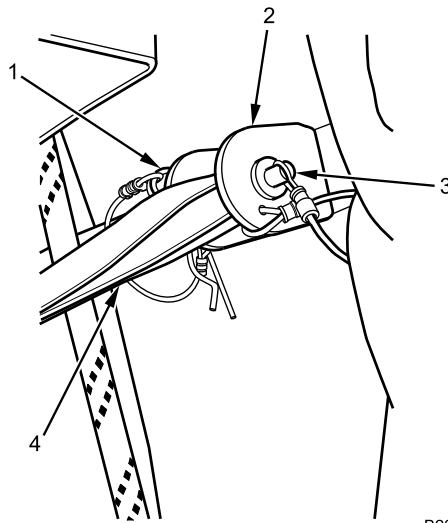

B231801983

Figure 20. Left Front Seat Hanger Safety Strap Anchor Pin.

14. Install anchor pin (Figure 20, Item 3) through seat bracket (Figure 20, Item 2) and left front seat hanger safety strap (Figure 20, Item 4).
15. Install anchor pin retainer (Figure 20, Item 1) on anchor pin (Figure 20, Item 3) securely.
16. Install left front seat hanger safety strap tensioner (Figure 21, Item 5) on left front floor seat bracket (Figure 21, Item 6) with two bolts (Figure 21, Item 1), flat washers, and nuts and tighten securely.

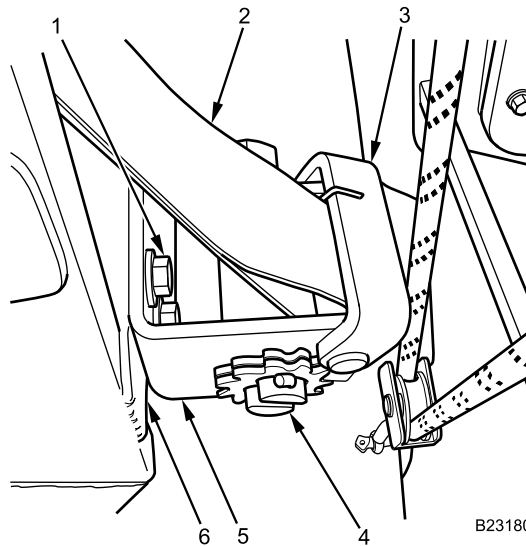

B231801982

Figure 21. Left Front Seat Hanger Safety Strap Tensioner.

17. Turn left front seat hanger safety strap tensioner wheel (Figure 21, Item 4) counterclockwise (Figure 21, Item 3) to tighten safety strap (Figure 21, Item 2). Ensure release lever (Figure 21, Item 3) is engaged with tensioner wheel.
18. Install cable lock straps as required.

END OF TASK

COMMUNICATIONS RACK REMOVAL AND INSTALLATION - (CONTINUED)**FOLLOW-ON MAINTENANCE**

1. Install FSS cabin cylinder (WP 0745).
2. Remove wheel chocks (TM 9-2355-106-10).

END OF TASK**END OF WORK PACKAGE**

FIELD MAINTENANCE

GUNNER PLATFORM/STAND REMOVAL AND INSTALLATION

INITIAL SETUP:

Tools and Special Tools

General Mechanic's Tool Kit (GMTK)
(WP 0795, Item 37)
Wrench, torque, click, ratcheting, 15-75 lb-ft, 3/8-inch
drive (WP 0795, Item 145)

Materials/Parts

Faceshield, industrial (WP 0794, Item 16)
Gloves (WP 0794, Item 18)
Goggles, industrial (WP 0794, Item 20)
Sealing compound (WP 0794, Item 45)

Personnel Required

Maintainer - (2)

References

TM 9-2355-106-10
TM 9-2355-106-23P
WP 0786
WP 0782

Equipment Condition

Parking brake set (TM 9-2355-106-10)
Transmission set in NEUTRAL (N) (TM
9-2355-106-10)
Engine off (TM 9-2355-106-10)
MAIN POWER switch off (TM 9-2355-106-10)
Wheels chocked (TM 9-2355-106-10)

NOTE

The vehicle is equipped with one of two gunner platform stand designs: solid metal platform and a grated metal platform.

REMOVAL – SOLID-METAL PLATFORM STAND

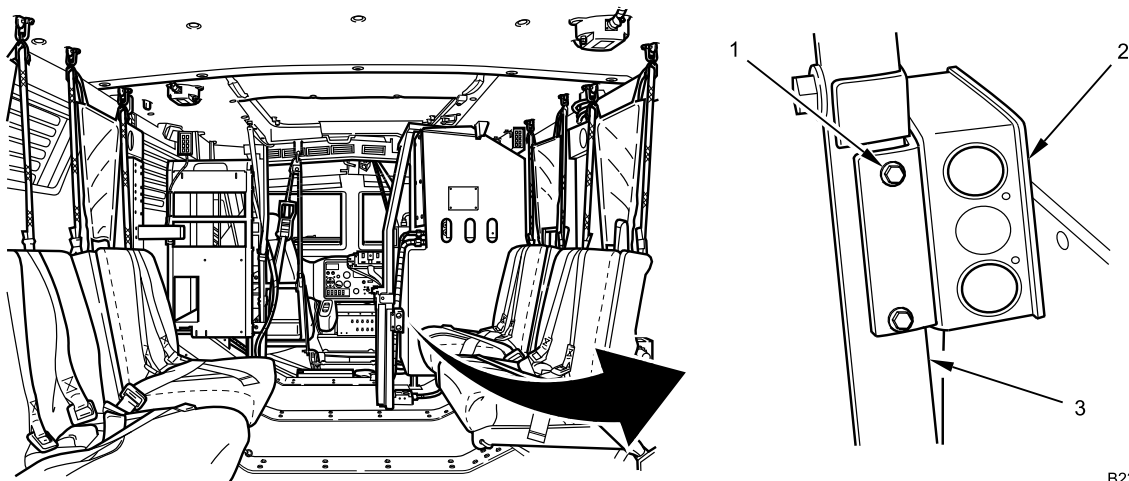

B231810622

Figure 1. 12-Volt Junction Box.

1. Remove two screws (Figure 1, Item 1) securing 12-volt junction box (Figure 1, Item 2) on gunner platform stand (Figure 1, Item 3). Position 12-volt junction box aside.

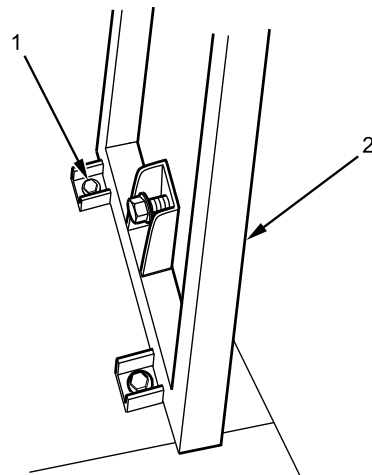
GUNNER PLATFORM/STAND REMOVAL AND INSTALLATION - (CONTINUED)

B231802409

Figure 2. Gunner Platform Stand Floor Mounting Bolts.

2. With gunner platform in upright position, remove two bolts (Figure 2, Item 1) securing gunner platform stand (Figure 2, Item 2) to floor.

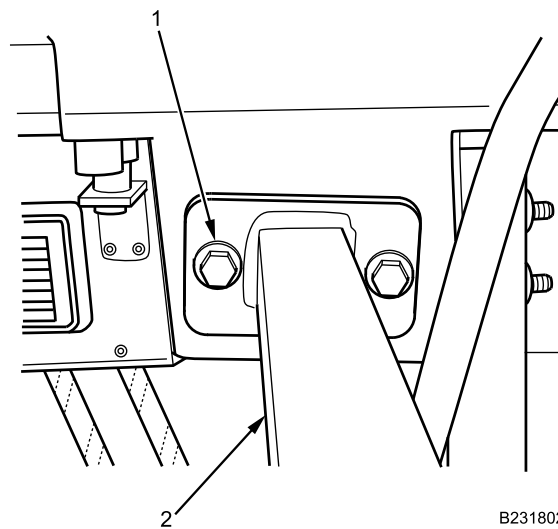

B231802410

Figure 3. Left Side Gunner Platform Stand Mounting Bolts.

3. With gunner platform in down position, remove two bolts (Figure 3, Item 1) and nuts securing gunner platform stand (Figure 3, Item 2) on upper front side cabin wall.

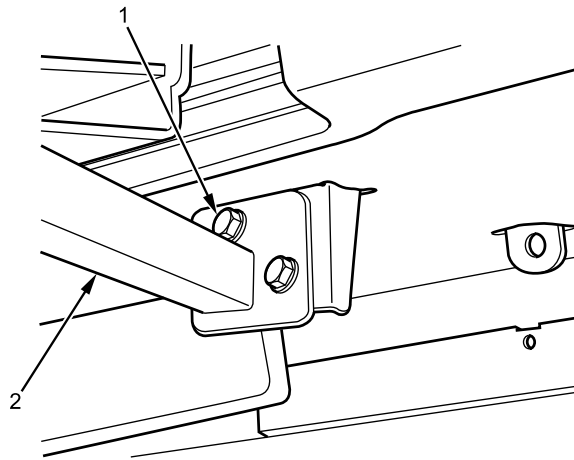
GUNNER PLATFORM/STAND REMOVAL AND INSTALLATION - (CONTINUED)

B231802408

Figure 4. Right Side Gunner Platform Stand Mounting Bolts.

4. With assistant, remove two bolts (Figure 4, Item 1) and nuts securing gunner platform stand (Figure 4, Item 2) on upper right side cabin wall. Remove gunner platform stand.

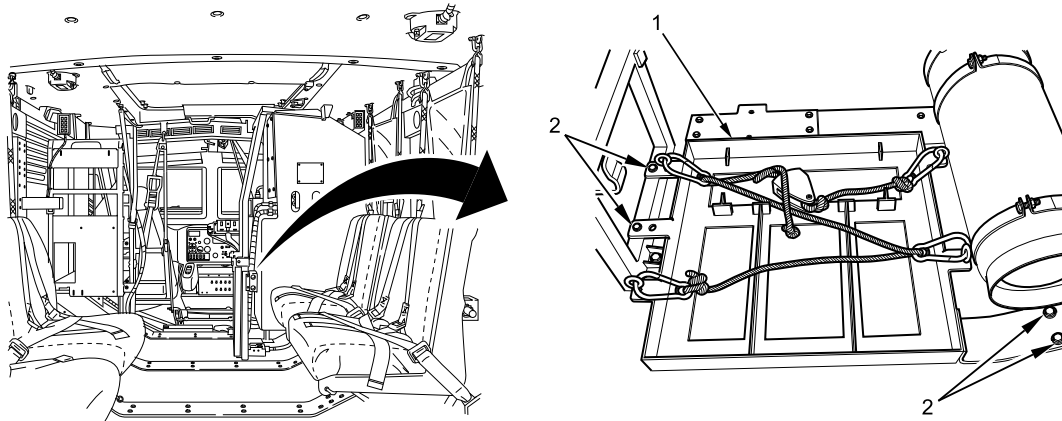
END OF TASK**REMOVAL – GRATED-METAL PLATFORM STAND**

B231810623

Figure 5. Ammunition Container Assembly.

1. Remove four bolts (Figure 5, Item 2) securing ammunition container assembly (Figure 5, Item 1) to floor. Remove ammunition container assembly.

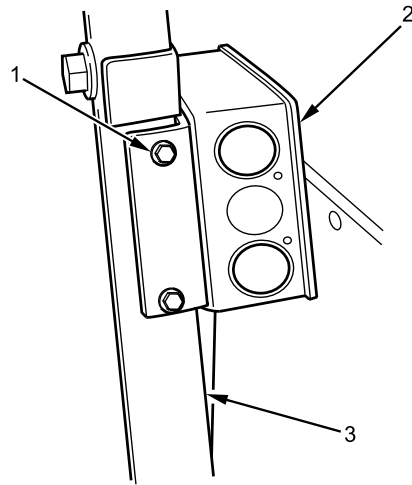
GUNNER PLATFORM/STAND REMOVAL AND INSTALLATION - (CONTINUED)

B231802411

Figure 6. 12-Volt Junction Box.

2. Remove two screws (Figure 6, Item 1) securing 12-volt junction box (Figure 6, Item 2) on gunner platform stand (Figure 6, Item 3). Position 12-volt junction box aside.

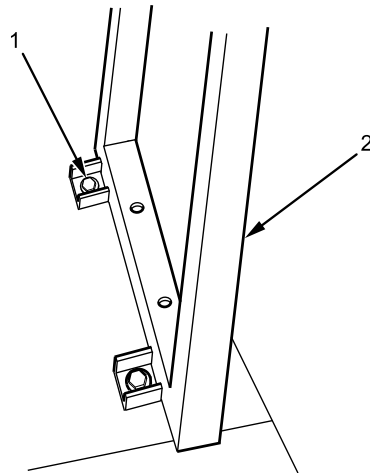

B231803081

Figure 7. Gunner Platform Stand Floor Mounting Bolts.

3. With gunner platform in upright position, remove two bolts (Figure 7, Item 1) securing gunner platform stand (Figure 7, Item 2) to floor.

GUNNER PLATFORM/STAND REMOVAL AND INSTALLATION - (CONTINUED)

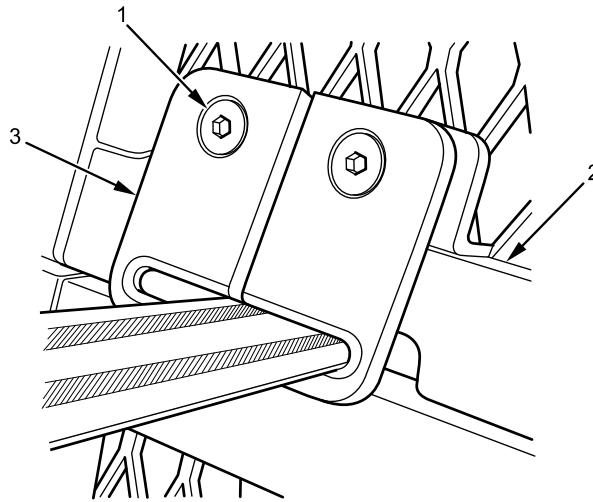

P231800308

Figure 8. Gunner Restraint Retaining Ring.

4. Remove two bolts (Figure 8, Item 1) securing gunner restraint retaining ring (Figure 8, Item 3) under gunner platform (Figure 8, Item 2). Remove gunner restraint retaining ring from platform and leave ring attached to belt.

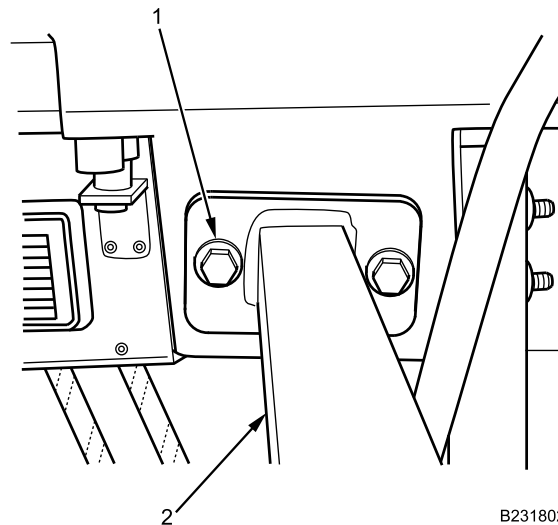

B231802410

Figure 9. Left Side Gunner Platform Stand Mounting Bolts.

5. With gunner platform in down position, remove two bolts (Figure 9, Item 1) and nuts securing gunner platform stand (Figure 9, Item 2) on upper front cabin wall.

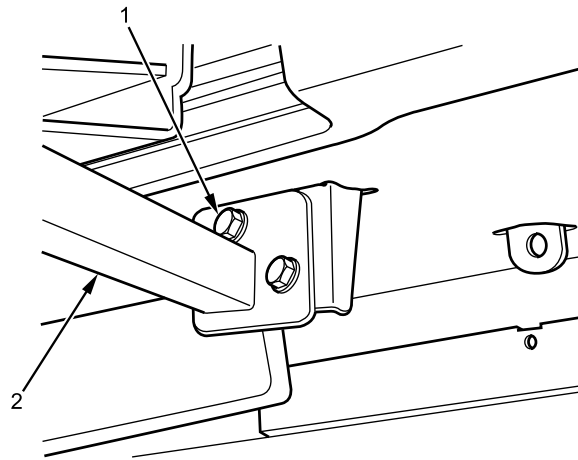
GUNNER PLATFORM/STAND REMOVAL AND INSTALLATION - (CONTINUED)

B231802408

Figure 10. Right Side Gunner Platform Stand Mounting Bolts.

6. With assistant, remove two bolts (Figure 10, Item 1) and nuts securing gunner platform stand (Figure 10, Item 2) on upper right cabin wall, and remove gunner platform stand by sliding stand back and up.

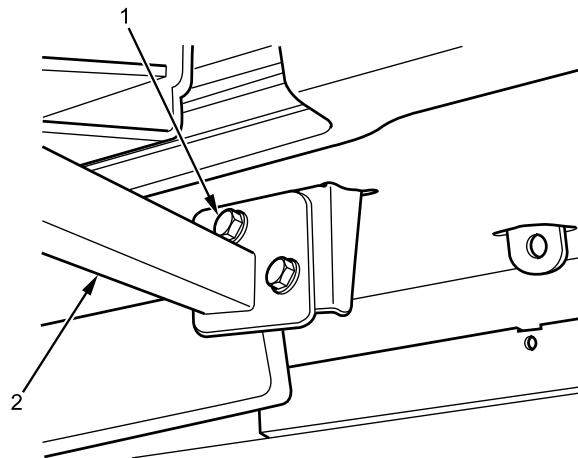
END OF TASK**INSTALL – SOLID METAL PLATFORM STAND**

B231802408

Figure 11. Right Side Gunner Platform Stand Mounting Bolts.

1. With assistant, position gunner platform stand (Figure 11, Item 2) on upper right side cabin wall and loosely install two bolts (Figure 11, Item 1) and nuts.

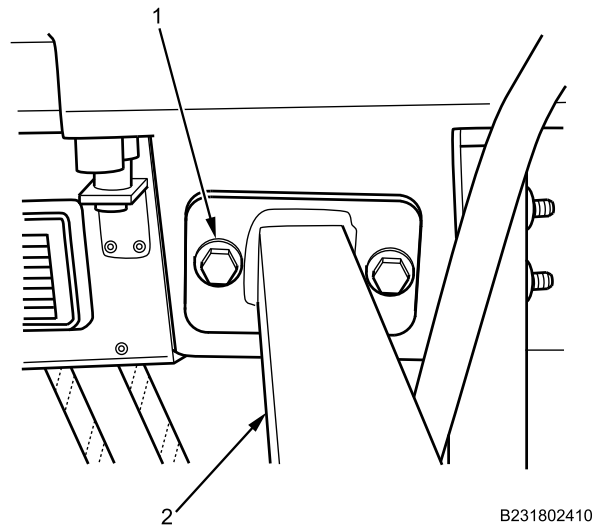
GUNNER PLATFORM/STAND REMOVAL AND INSTALLATION - (CONTINUED)

B231802410

Figure 12. Left Side Gunner Platform Stand Mounting Bolts.

2. Install two bolts (Figure 12, Item 1) and nuts loosely securing gunner platform stand (Figure 12, Item 2) on upper front side cabin wall.
3. Tighten four bolts (Figure 12, Item 1) and (Figure 11, Item 1) securely.

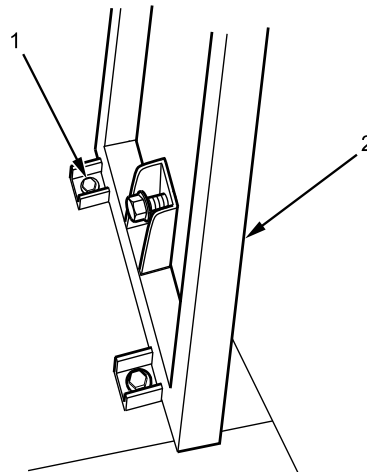

B231802409

Figure 13. Gunner Platform Floor Mounting Bolts.

4. With gunner platform in upright position, install two bolts (Figure 13, Item 1) securing gunner platform stand (Figure 13, Item 2) to floor. Tighten bolts securely.

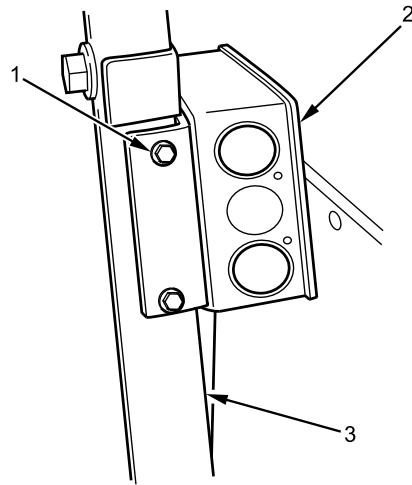
GUNNER PLATFORM/STAND REMOVAL AND INSTALLATION - (CONTINUED)

B231802411

Figure 14. 12-Volt Junction Box.

5. Install 12-volt junction box (Figure 14, Item 2) on gunner platform stand (Figure 14, Item 3) with two screws (Figure 14, Item 1). Tighten screws securely.

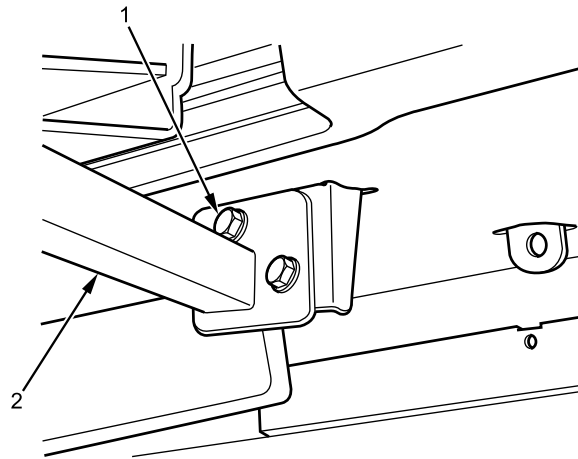
END OF TASK**INSTALL – GRATED-METAL PLATFORM STAND**

B231802408

Figure 15. Right Side Gunner Platform Stand Mounting Bolts.

1. With assistant, install gunner platform stand (Figure 15, Item 2) on upper right cabin wall with two bolts (Figure 15, Item 1) and new nuts. Tighten bolts securely.

GUNNER PLATFORM/STAND REMOVAL AND INSTALLATION - (CONTINUED)

Figure 16. Left Side Gunner Platform Stand Mounting Bolts.

2. Install two bolts (Figure 16, Item 1) and new nuts securing gunner platform stand (Figure 16, Item 2) on upper front cabin wall. Tighten bolts securely.

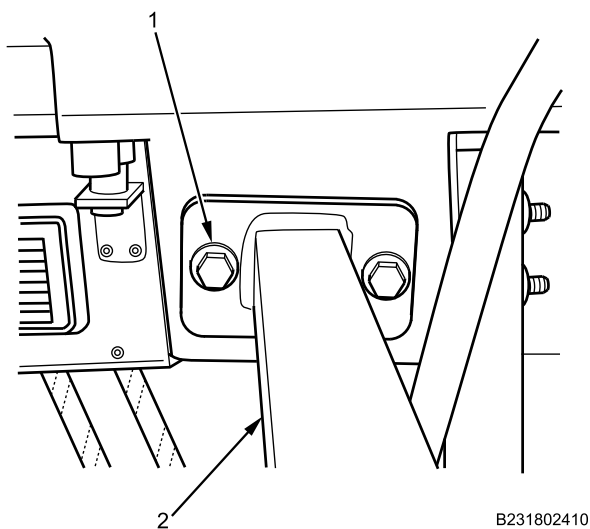
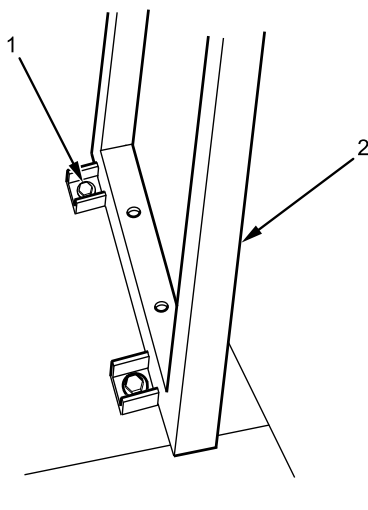
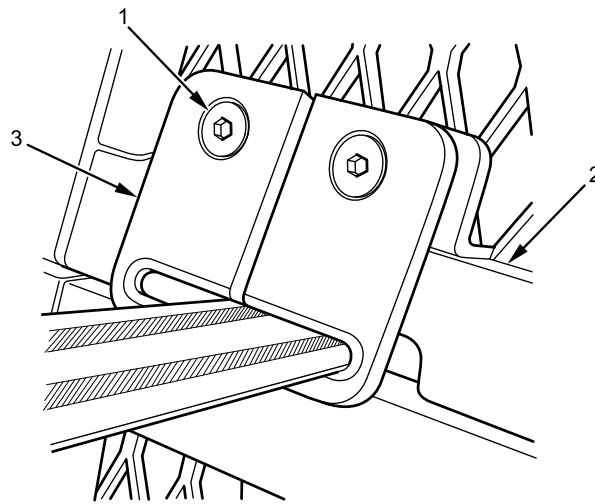

Figure 17. Gunner Platform Stand Floor Mounting Bolts.

3. With gunner platform in upright position, install two bolts (Figure 17, Item 1) securing gunner platform stand (Figure 17, Item 2) to floor. Tighten bolts securely.

GUNNER PLATFORM/STAND REMOVAL AND INSTALLATION - (CONTINUED)

P231800308

Figure 18. Gunner Restraint Retaining Ring.

WARNING

Thread sealing compound is harmful to skin and eyes. If thread sealing compound contacts eyes, rinse thoroughly and contact physician if irritation persists. If skin is contacted, wash thoroughly with soap and water. Failure to comply may result in serious injury to personnel.

4. Apply thread sealing compound on two retaining ring mounting bolts (Figure 18, Item 3).

CAUTION

Ensure restraint strap is not twisted during retaining ring installation.

5. Install gunner restraint retaining ring (Figure 18, Item 3) under gunner platform (Figure 18, Item 2) with two bolts (Figure 18, Item 1). Using torque wrench, torque bolts to 25 lb-ft (34 N•m).

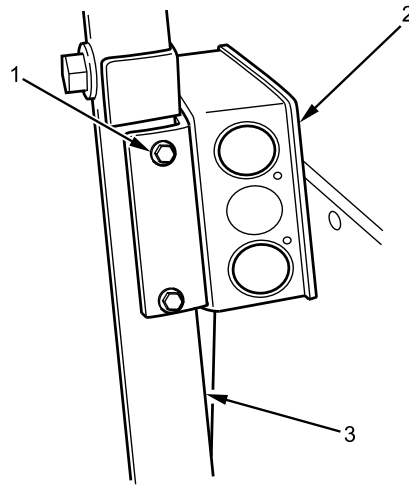
GUNNER PLATFORM/STAND REMOVAL AND INSTALLATION - (CONTINUED)

B231802411

Figure 19. 12-Volt Junction Box.

6. Install 12-volt junction box (Figure 19, Item 2) on gunner platform stand (Figure 19, Item 3) with two screws (Figure 19, Item 1). Tighten screws securely.

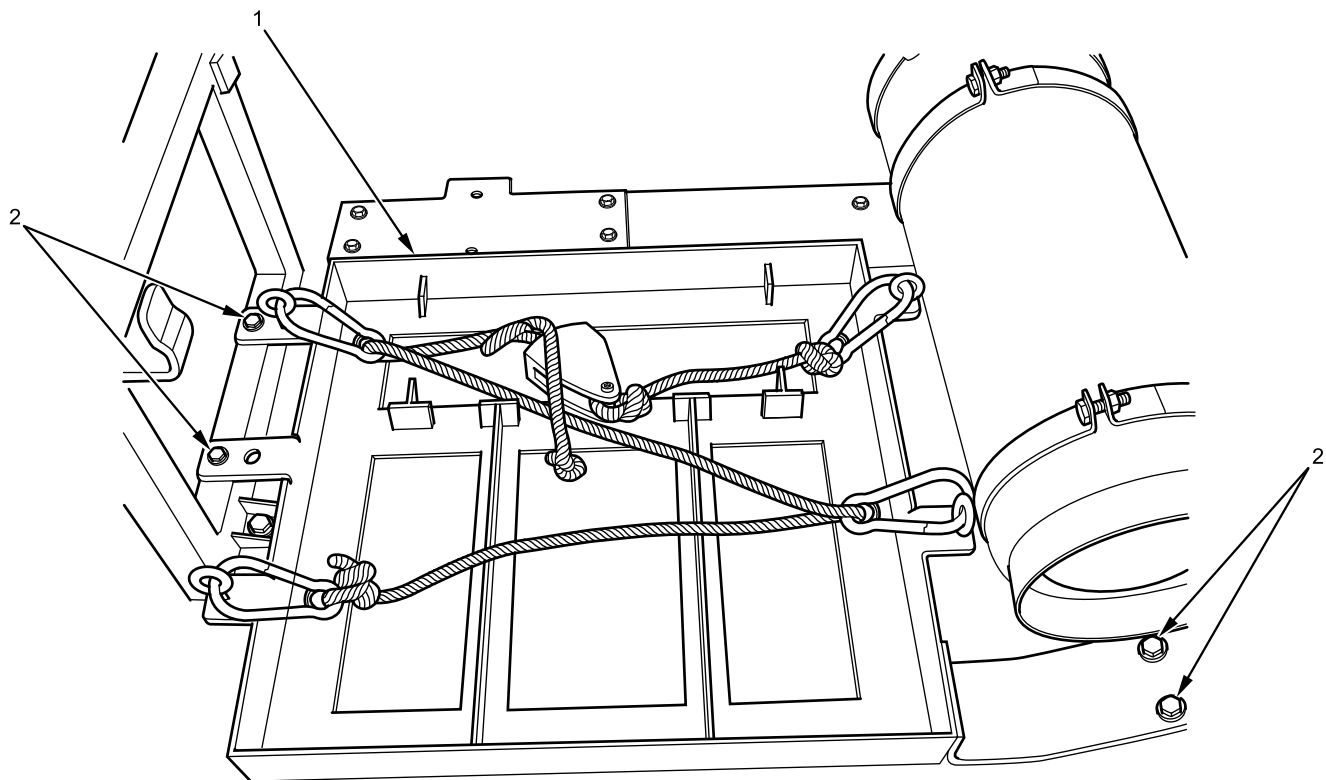
GUNNER PLATFORM/STAND REMOVAL AND INSTALLATION - (CONTINUED)

B231803082

Figure 20. Ammunition Container Assembly.

7. Install ammunition container assembly (Figure 20, Item 1) to floor with four bolts (Figure 20, Item 2). Tighten bolts securely.

END OF TASK**FOLLOW-ON MAINTENANCE**

1. Remove wheel chocks (TM 9-2355-106-10).

END OF TASK**END OF WORK PACKAGE**

FIELD MAINTENANCE

GUNNER RESTRAINT ASSEMBLY REMOVAL AND INSTALLATION

INITIAL SETUP:

Tools and Special Tools

General Mechanic's Tool Kit (GMTK)
(WP 0795, Item 37)
Wrench, torque, 20-100 lb-ft, 3/8-inch drive
(WP 0795, Item 141)

Materials/Parts

Sealing compound (WP 0794, Item 44)

Personnel Required

Maintainer - (2)

References

TM 9-2355-106-10

TM 9-2355-106-23P

WP 0786

WP 0782

Equipment Condition

Parking brake set (TM-9-2355-106-10)

Transmission set in NEUTRAL (N)
(TM-9-2355-106-10)

Engine off (TM-9-2355-106-10)

MAIN POWER switch off (TM-9-2355-106-10)

Wheels chocked (TM-9-2355-106-10)

REMOVAL

1. Remove two bolts (Figure 1, Item 1) securing gunner restraint retaining ring (Figure 1, Item 3) under gunner platform (Figure 1, Item 2). Remove gunner restraint retaining ring.

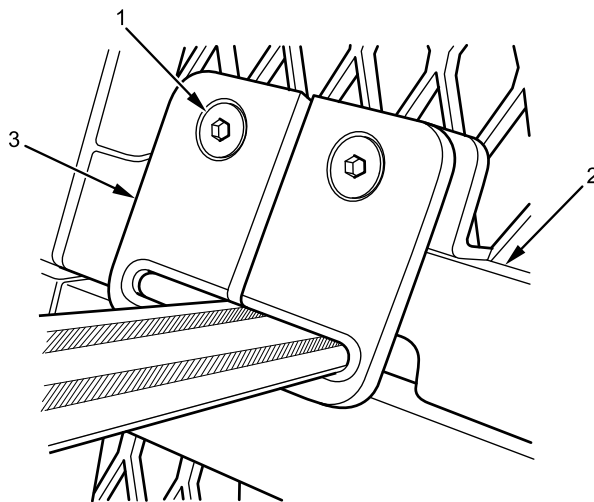

P231800308

Figure 1. Gunner Restraint Retaining Ring.

GUNNER RESTRAINT ASSEMBLY REMOVAL AND INSTALLATION - (CONTINUED)

2. Remove rear mounting bolt (Figure 2, Item 2) securing retractor assembly (Figure 2, Item 1) to mounting plate.

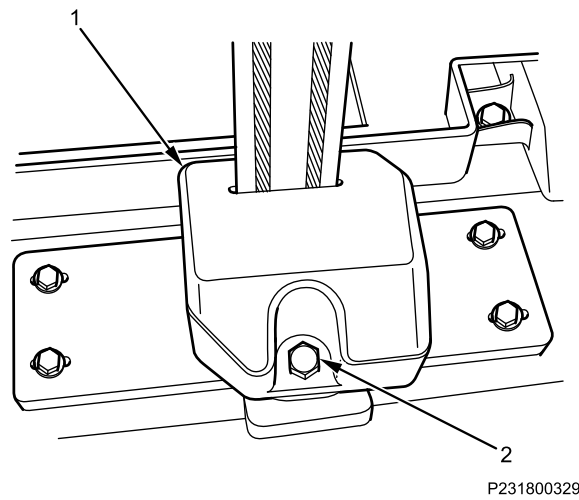

Figure 2. Retractor Assembly Rear Mounting Bolt.

3. Extend restraint strap (Figure 3, Item 2) and remove retractor cap (Figure 3, Item 1) from retractor assembly (Figure 3, Item 3).

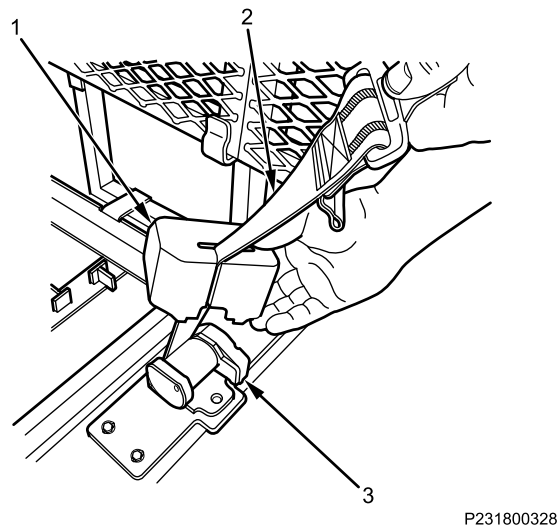
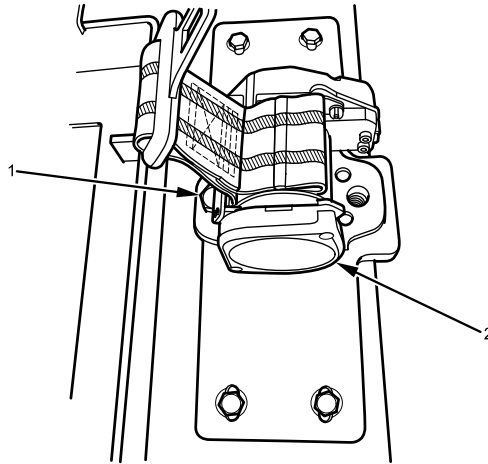

Figure 3. Retractor Cap.

GUNNER RESTRAINT ASSEMBLY REMOVAL AND INSTALLATION - (CONTINUED)

4. Remove front mounting bolt (Figure 4, Item 1) securing retractor assembly (Figure 4, Item 2) to mounting plate. Remove retractor assembly.



P231800327

Figure 4. Retractor Assembly Front Mounting Bolt.

5. Remove four bolts (Figure 5, Item 1) securing retractor assembly mounting plate (Figure 5, Item 2) on floor. Remove mounting plate.

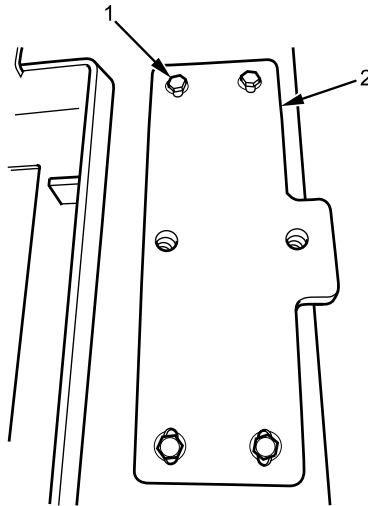

P233300433

Figure 5. Retractor Assembly Mounting Plate.

END OF TASK

GUNNER RESTRAINT ASSEMBLY REMOVAL AND INSTALLATION - (CONTINUED)**INSTALLATION**

1. Install retractor assembly mounting plate (Figure 6, Item 2) on floor with four bolts (Figure 6, Item 1). Torque bolts to 12 lb-ft (16 N•m).

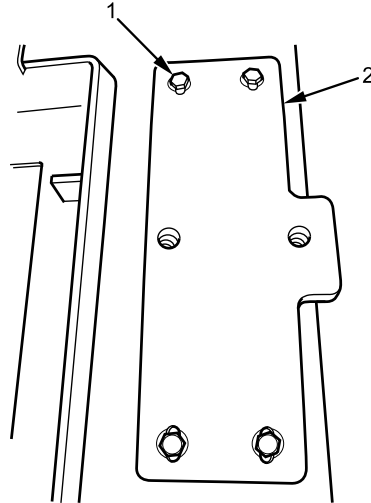

P233300433

Figure 6. Retractor Assembly Mounting plate.

NOTE

Rear mounting bolt is used as a guide to align rear bolthole. Do not tighten rear mounting bolt at this time.

2. Install retractor assembly (Figure 7, Item 1) on mounting plate with front and rear mounting bolts (Figure 7, Item 2 and 3). Torque front bolt to 68 lb-ft (92 N•m) and leave rear mounting bolt (Figure 7, Item 2) loose. Remove rear mounting bolt after front mounting bolt has been torqued.

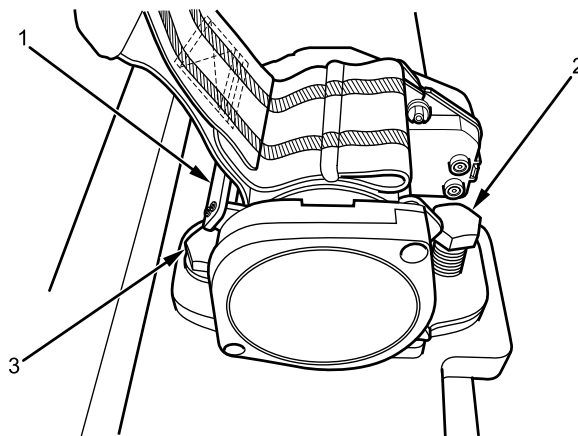

P231800333

Figure 7. Retractor Assembly Mounting Bolts.

GUNNER RESTRAINT ASSEMBLY REMOVAL AND INSTALLATION - (CONTINUED)

3. Extend restraint strap (Figure 8, Item 2) and install retractor cap (Figure 8, Item 1) on retractor assembly (Figure 8, Item 3).

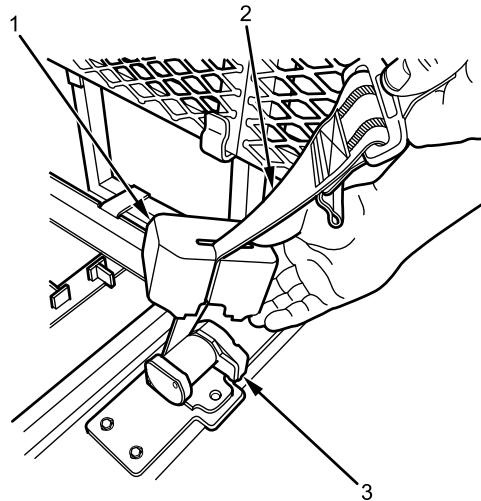

P231800328

Figure 8. Retractor Cap.

4. Install rear mounting bolt (Figure 9, Item 2) on retractor assembly (Figure 9, Item 1). Torque mounting bolt to 68 lb-ft (92 N•m).

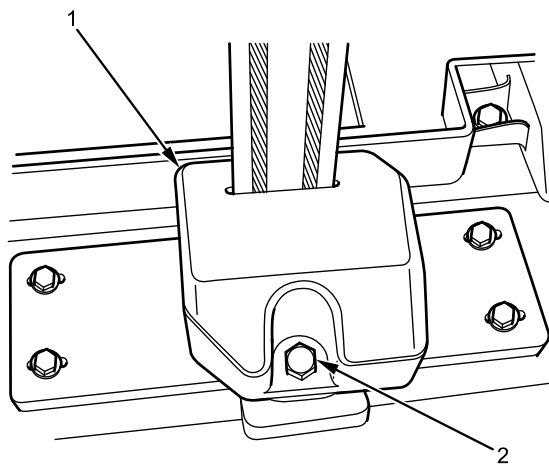

P231800329

Figure 9. Retractor Assembly Rear Mounting Bolt.

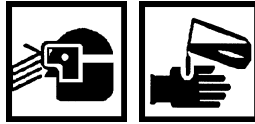
GUNNER RESTRAINT ASSEMBLY REMOVAL AND INSTALLATION - (CONTINUED)**WARNING**

Thread sealing compound is harmful to skin and eyes. If thread sealing compound contacts eyes, rinse thoroughly and contact physician if irritation persists. If skin is contacted, wash thoroughly with soap and water. Failure to comply may result in serious injury to personnel.

6. Apply thread sealing compound on two retaining ring mounting bolts (Figure 10, Item 1).

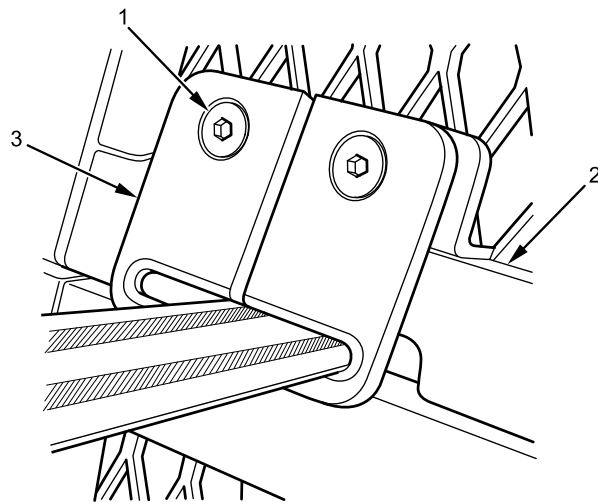

P231800308

Figure 10. Gunner Restraint Retaining Ring.

CAUTION

Ensure restraint strap is not twisted during retaining ring installation.

7. Install gunner restraint retaining ring (Figure 10, Item 3) under gunner platform (Figure 10, Item 2) with two bolts (Figure 10, Item 1). Torque bolts to 25 lb-ft (34 N•m).

END OF TASK**FOLLOW-ON MAINTENANCE**

Remove wheel chocks (TM-9-2355-106-10).

END OF TASK**END OF WORK PACKAGE**

FIELD MAINTENANCE

REAR COMMUNICATION RACK REMOVAL AND INSTALLATION

INITIAL SETUP:

Tools and Special Tools

General Mechanic's Tool Kit (GMTK)
(WP 0795, Item 37)
Belly Armor Removal/Installer Kit (WP 0795, Item
16)

Materials/Parts

Locknut - (4) (WP 0796, Item 175)

References

TM 9-2355-106-10

TM 9-2355-106-23P

WP 0786

WP 0782

Equipment Condition

Parking brake set (TM 9-2355-106-10)

Transmission set in NEUTRAL (N) (TM
9-2355-106-10)

Engine off (TM 9-2355-106-10)

MAIN POWER switch off (TM 9-2355-106-10)

Wheels chocked (TM 9-2355-106-10)

REMOVAL

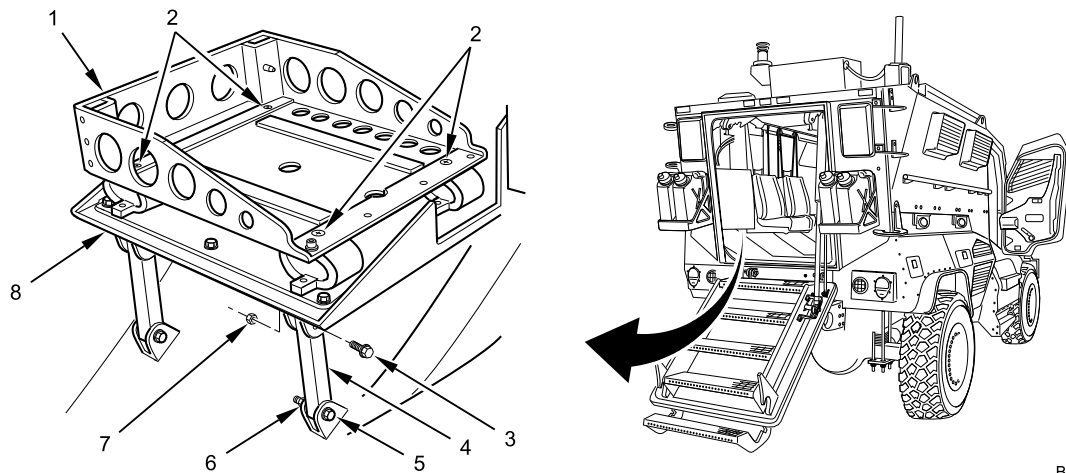

B231810803

Figure 1. Rear Communication Rack Upper Tray.

1. Remove four screws (Figure 1, Item 2) and upper tray (Figure 1, Item 1) from rear communication rack (Figure 1, Item 8).
2. Remove locknut (Figure 1, Item 7) and bolt (Figure 1, Item 3) from right front support leg (Figure 1, Item 4) on communication rack (Figure 1, Item 8). Discard locknut.

NOTE

Retain locknut for temporary re-use in procedure.

3. Remove locknut (Figure 1, Item 6) and bolt (Figure 1, Item 5) from right front support leg (Figure 1, Item 4) on floor mounting bracket, and remove support leg.

REAR COMMUNICATION RACK REMOVAL AND INSTALLATION - (CONTINUED)

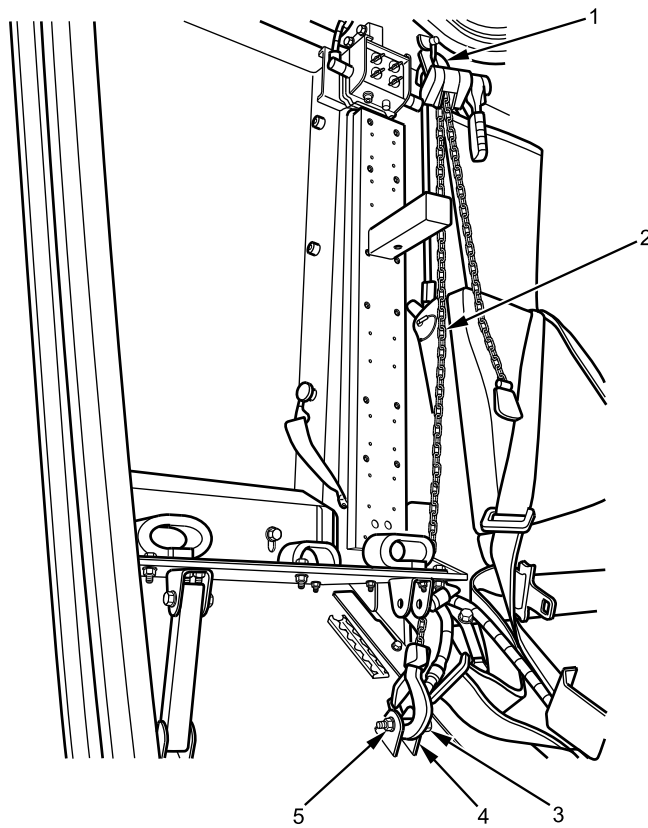

B231810805

Figure 2. Chain Hoist.

4. Install locknut (Figure 2, Item 5) and bolt (Figure 2, Item 3) back into right front support leg mounting bracket (Figure 2, Item 4) on floor.

NOTE

The chain hoist will support floor panel during communication rack removal.

5. Install chain hoist (Figure 2, Item 2) on roof bracket (Figure 2, Item 1) and right front support leg mounting bolt and bracket (Figure 2, Item 4) on floor.
6. Apply tension to chain hoist (Figure 2, Item 2).
7. Remove bolt (Figure 3, Item 3) and locknut (Figure 3, Item 7) from left front support leg (Figure 3, Item 6) on communication rack (Figure 3, Item 2). Discard locknut.

REAR COMMUNICATION RACK REMOVAL AND INSTALLATION - (CONTINUED)

Figure 3. Rear Communication Rack.

8. Remove bolt (Figure 3, Item 4) and locknut (Figure 3, Item 5) from left front support leg (Figure 3, Item 6) on communication rack (Figure 3, Item 2). Remove support leg (Figure 3, Item 6). Discard locknut.
9. Remove two upper bolts (Figure 3, Item 1) from communication rack (Figure 3, Item 2) and remove rack.

END OF TASK**INSTALLATION**

Figure 4. Rear Communication Rack.

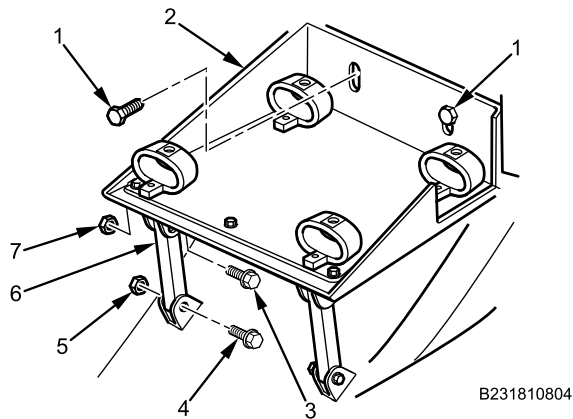
1. Install rear communication rack (Figure 4, Item 2) on hull with two upper bolts (Figure 4, Item 1). Do not tighten bolts.
2. Install left front support leg (Figure 4, Item 6) on communication rack (Figure 4, Item 2) with bolt (Figure 4, Item 3) and new locknut (Figure 4, Item 7). Do not tighten bolt.
3. Secure left front support leg (Figure 4, Item 6) on floor mounting bracket with bolt (Figure 4, Item 4) and new locknut (Figure 4, Item 5). Tighten all bolts securely.

REAR COMMUNICATION RACK REMOVAL AND INSTALLATION - (CONTINUED)

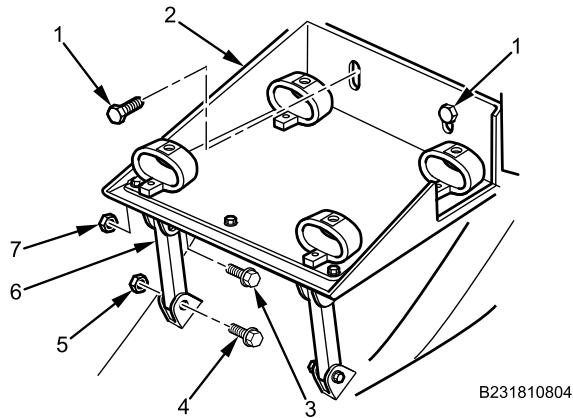
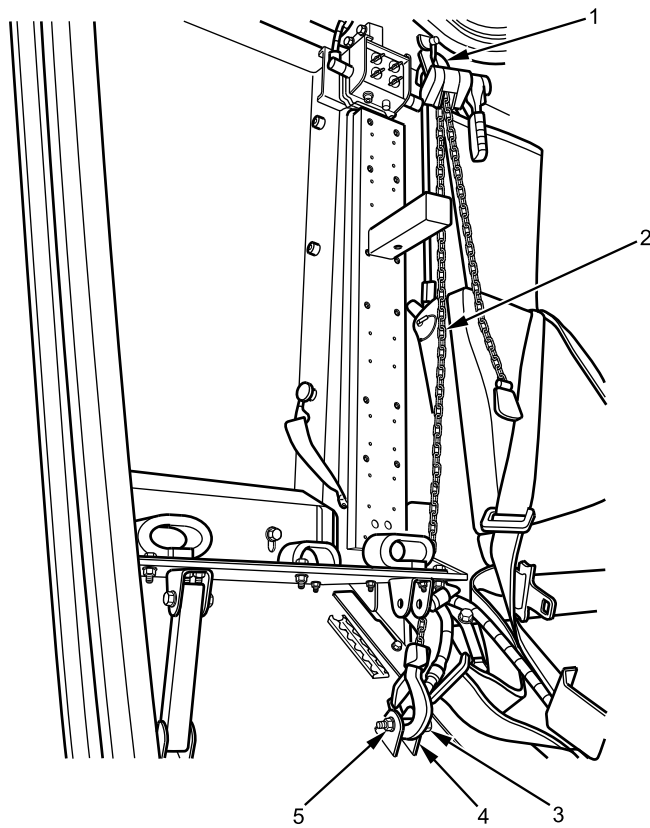

B231810805

Figure 5. Chain Hoist.

4. Release tension from chain hoist (Figure 5, Item 2).
5. Disconnect chain hoist (Figure 5, Item 2) from roof bracket (Figure 5, Item 1) and floor bracket (Figure 5, Item 4).
6. Remove bolt (Figure 5, Item 3) and locknut (Figure 5, Item 5) from support leg mounting bracket (Figure 5, Item 4) on floor. Discard locknut (Figure 5, Item 5).

REAR COMMUNICATION RACK REMOVAL AND INSTALLATION - (CONTINUED)

Figure 6. Communications Rack Upper Tray.

7. Install right front support leg (Figure 6, Item 4) on communication rack (Figure 6, Item 8) with new locknut (Figure 6, Item 6) and bolt (Figure 6, Item 5). Do not tighten locknut.
8. Secure right front support leg (Figure 6, Item 4) on communication rack (Figure 6, Item 8) with new locknut (Figure 6, Item 7) and bolt (Figure 6, Item 3). Tighten all bolts and locknuts securely.
9. Align boltholes of upper tray (Figure 6, Item 1) with holes in communication rack (Figure 6, Item 8) and secure with four screws (Figure 6, Item 2). Tighten screws securely.

END OF TASK**FOLLOW-ON MAINTENANCE**

1. Remove wheel chocks (TM 9-2355-106-10).

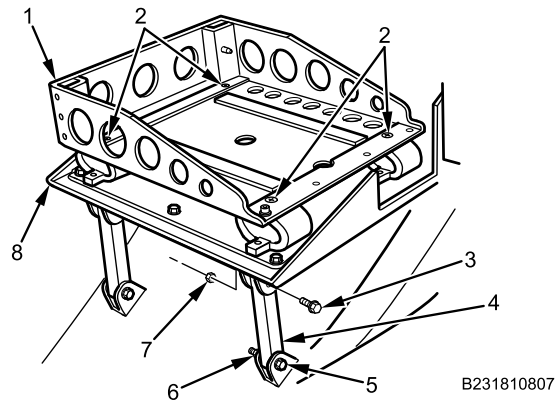
END OF TASK**END OF WORK PACKAGE**

FIELD MAINTENANCE

RIGHT SIDE FORWARD STOWAGE BOX REMOVAL AND INSTALLATION

INITIAL SETUP:

Tools and Special Tools

General Mechanic's Tool Kit (GMTK)
(WP 0795, Item 37)

References

TM 9-2355-106-10
TM 9-2355-106-23P
WP 0786
WP 0782

Equipment Condition

Parking brake set (TM 9-2355-106-10)
Transmission set in NEUTRAL (N) (TM
9-2355-106-10)

Engine off (TM 9-2355-106-10)

MAIN POWER switch off (TM 9-2355-106-10)

Wheels chocked (TM 9-2355-106-10)

Air Conditioning (A/C) condenser panel removed
(WP 0672)

Right side rear stowage box removed (WP 0673)

110V inverter removed (WP 0352)

Air hose quick connect pass-thru removed
(WP 0513)

Inverter megafuse and holder removed (WP 0449)

110V inverter MAIN POWER switch removed
(WP 0447)

NATO jump start connector removed (WP 0421)

REMOVAL

1. Remove four bolts (Figure 1, Item 3) securing right side forward stowage box (Figure 1, Item 2) to body.

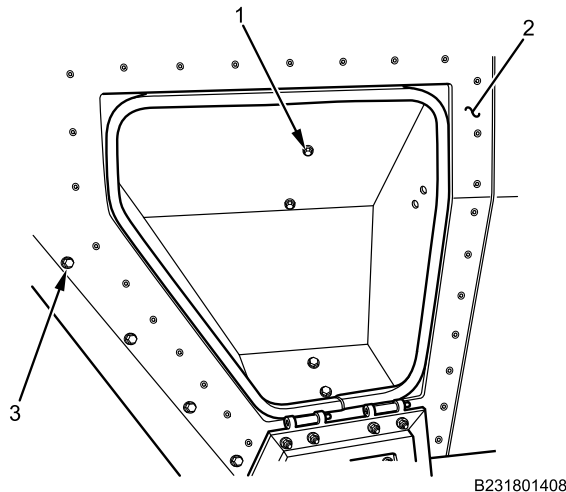

Figure 1. Right Side Forward Stowage Box Removal.

2. Remove four bolts (Figure 1, Item 1) from inside stowage box securing right side forward stowage box (Figure 1, Item 2) to body.

END OF TASK

RIGHT SIDE FORWARD STOWAGE BOX REMOVAL AND INSTALLATION - (CONTINUED)**INSTALLATION**

1. Position right side forward stowage box (Figure 2, Item 2) to body.

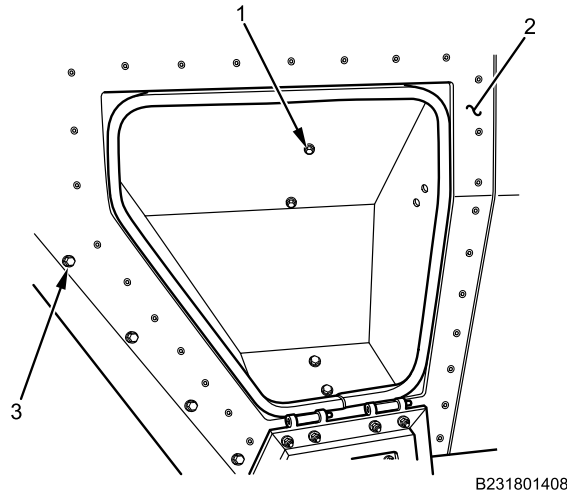

Figure 2. Right Side Forward Stowage Box Installation.

2. Loosely install four bolts (Figure 2, Item 1) inside stowage box (Figure 2, Item 2).
3. Install four bolts (Figure 2, Item 3) securing right side forward stowage box (Figure 2, Item 2) to body and tighten securely.
4. Tighten four bolts (Figure 2, Item 1) inside stowage box (Figure 2, Item 2) securely.

END OF TASK**FOLLOW-ON MAINTENANCE**

1. Install NATO jump start connector (WP 0421).
2. Install 110V MAIN POWER switch (WP 0447).
3. Install inverter megafuse and holder (WP 0449).
4. Install air hose quick connect pass-thru (WP 0513).
5. Install 110V inverter (WP 0352).
6. Install right side rear stowage box. (WP 0676).
7. Install A/C condenser panel (WP 0672).
8. Remove wheel chocks (TM 9-2355-106-10).

END OF TASK**END OF WORK PACKAGE**

FIELD MAINTENANCE

AIR CONDITIONING (A/C) CONDENSER PANEL REMOVAL AND INSTALLATION

INITIAL SETUP:

Tools and Special Tools

General Mechanic's Tool Kit (GMTK)
(WP 0795, Item 37)

References

TM 9-2355-106-10
TM 9-2355-106-23P
WP 0786
WP 0782

Equipment Condition

Parking brake set (TM 9-2355-106-10)
Transmission set in NEUTRAL (N) (TM
9-2355-106-10)
Engine off (TM 9-2355-106-10)
MAIN POWER switch off (TM 9-2355-106-10)
Wheels chocked (TM 9-2355-106-10)

REMOVAL

NOTE

Right side shown, left side similar.

1. Remove six bolts (Figure 1, Item 1) and flat washers from A/C condenser panel.

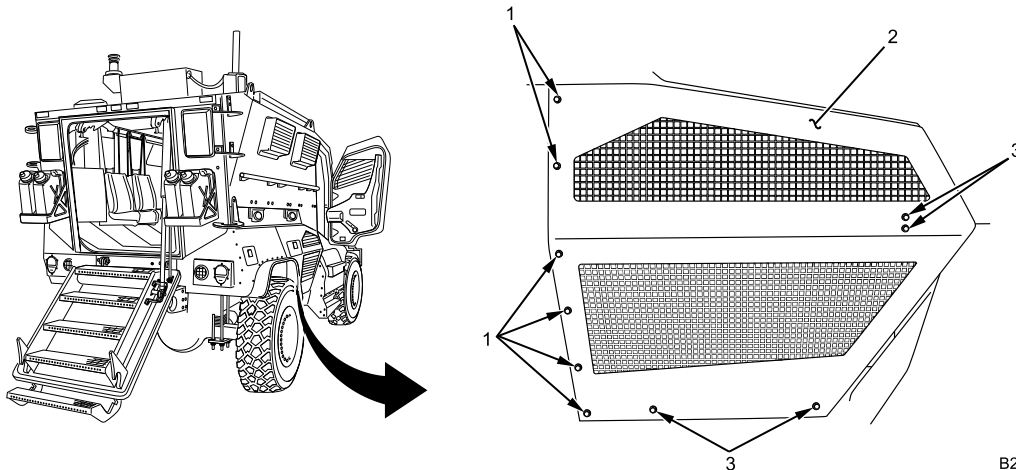

B231810625

Figure 1. A/C Condenser Panel Removal.

2. Remove four bolts (Figure 1, Item 3) and flat washers from A/C condenser panel (Figure 1, Item 2) and remove panel.

END OF TASK

AIR CONDITIONING (A/C) CONDENSER PANEL REMOVAL AND INSTALLATION - (CONTINUED)**INSTALLATION**

1. Position A/C condenser panel (Figure 2, Item 2) on body.

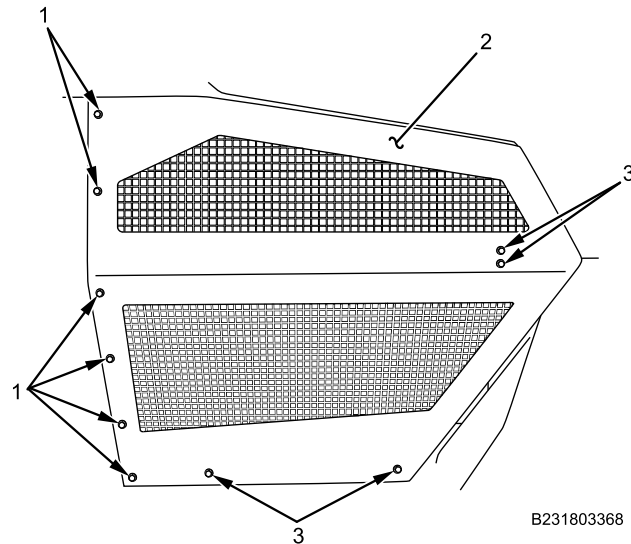

Figure 2. A/C Condenser Panel Installation.

2. Install four bolts (Figure 2, Item 3) and flat washers on A/C condenser panel (Figure 2, Item 2). Do not tighten
3. Install six bolts (Figure 2, Item 1) and flat washers on A/C condenser panel (Figure 2, Item 2) and tighten securely.
4. Tighten four bolts (Figure 2, Item 3) securely.

END OF TASK**FOLLOW-ON MAINTENANCE**

1. Remove wheel chocks (TM 9-2355-106-10).

END OF TASK**END OF WORK PACKAGE**

FIELD MAINTENANCE**RIGHT SIDE REAR STOWAGE BOX REMOVAL AND INSTALLATION**

INITIAL SETUP:**Tools and Special Tools**

General Mechanic's Tool Kit (GMTK)
(WP 0795, Item 37)

TM 9-2355-106-23P

WP 0786

WP 0782

Materials/Parts

Grease (WP 0794, Item 22)
Gloves (WP 0794, Item 18)
Goggles, industrial (WP 0794, Item 20)
Faceshield, industrial (WP 0794, Item 16)

Equipment Condition

Parking brake set (TM 9-2355-106-10)
Transmission set in NEUTRAL (N) (TM
9-2355-106-10)
Engine off (TM 9-2355-106-10)
MAIN POWER switch off (TM 9-2355-106-10)
Wheels chocked (TM 9-2355-106-10)
110V cover, outlet, and box removed (WP 0328)

References

TM 9-2355-106-10

RIGHT SIDE REAR STOWAGE BOX REMOVAL AND INSTALLATION - (CONTINUED)

REMOVAL

1. Remove nut (Figure 1, Item 2) and bolt (Figure 2, Item 1) securing sidemarker light harness (Figure 1, Item 1) to stowage bin (Figure 2, Item 2).

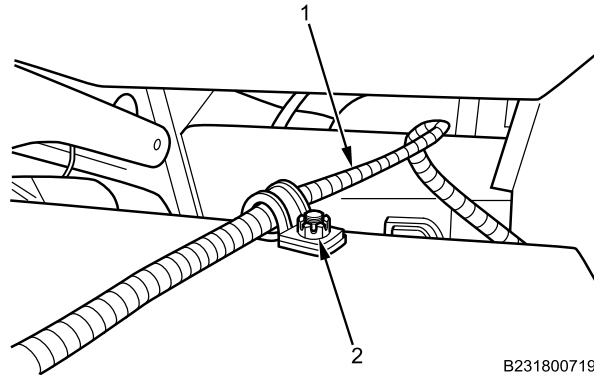

Figure 1. Sidemarker Harness Retainer.

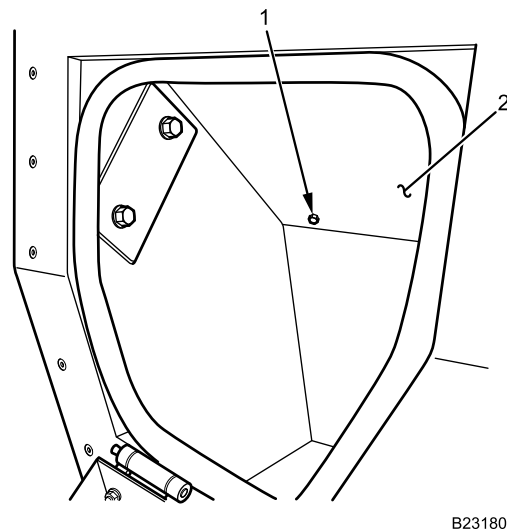

Figure 2. Sidemarker Harness Bolt.

2. Remove 16 bolts and washers (Figure 3, Item 1 and 4) securing right side rear stowage box (Figure 3, Item 2) to body.

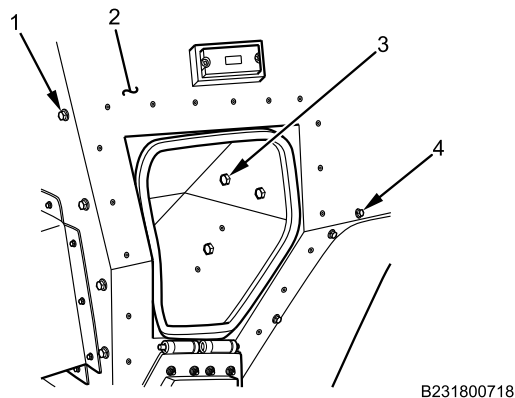

Figure 3. Right Rear Stowage Box Removal.

RIGHT SIDE REAR STOWAGE BOX REMOVAL AND INSTALLATION - (CONTINUED)

3. Remove four bolts (Figure 3, Item 3) securing right side rear stowage box (Figure 3, Item 2) to body from inside box.
4. Pull right side rear stowage box away from body and disconnect power wire (Figure 4, Item 3) from sidemarker light.

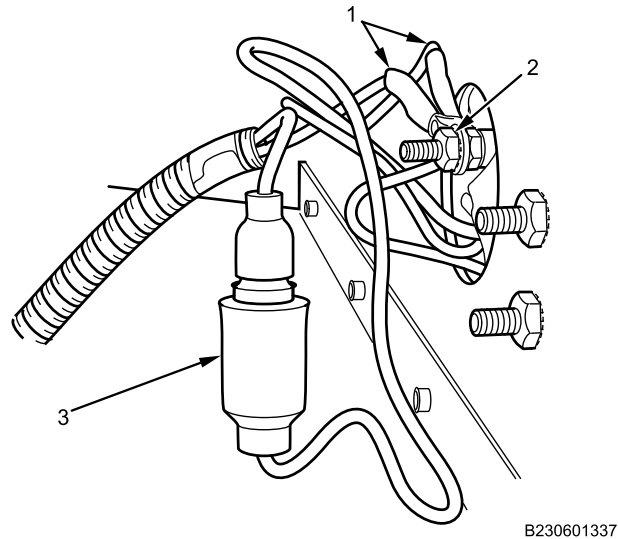

Figure 4. Sidemarker Light.

5. Remove nut (Figure 4, Item 2) securing ground wires (Figure 4, Item 1) to sidemarker light.
6. Remove right side rear stowage box.

END OF TASK

RIGHT SIDE REAR STOWAGE BOX REMOVAL AND INSTALLATION - (CONTINUED)**INSTALLATION****WARNING**

Dielectric grease is harmful to skin and eyes. If grease contacts eyes, rinse thoroughly and contact physician if irritation persists. If skin is contacted, wash thoroughly with soap and water. Failure to comply may result in serious injury to personnel.

NOTE

Apply dielectric grease to all electrical connections.

1. Position right side rear stowage box on body.

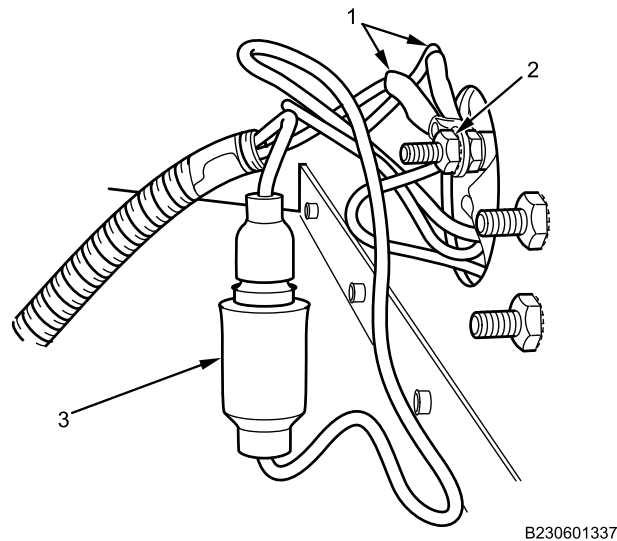

Figure 5. Sidemarker Light Wiring.

2. Connect sidemarker light positive wire (Figure 5, Item 3) to harness.
3. Position ground wires (Figure 5, Item 1) and install nut (Figure 5, Item 2) and tighten securely.

RIGHT SIDE REAR STOWAGE BOX REMOVAL AND INSTALLATION - (CONTINUED)

4. Align right side rear stowage box (Figure 6, Item 2) to body.

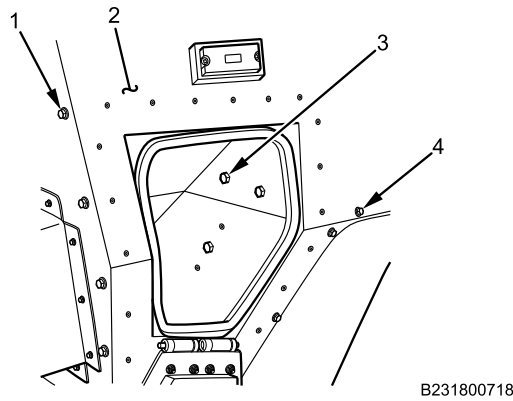
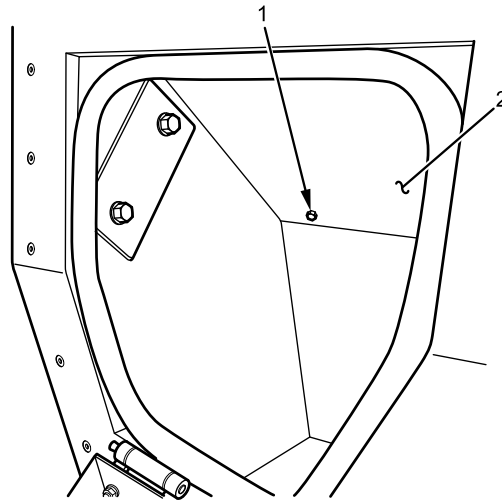

Figure 6. Right Side Rear Stowage Box Installation.

5. Loosely install four bolts (Figure 6, Item 3) inside stowage box (Figure 6, Item 2).
6. Install 16 bolts (Figure 6, Item 1 and 4) securing right side rear stowage box (Figure 6, Item 2) to body and tighten securely.
7. Tighten four bolts (Figure 6, Item 3) inside stowage box (Figure 6, Item 2) securely.

RIGHT SIDE REAR STOWAGE BOX REMOVAL AND INSTALLATION - (CONTINUED)

8. Install nut (Figure 8, Item 2) and bolt (Figure 7, Item 1) securing sidemarker light harness (Figure 8, Item 1) to stowage bin (Figure 7, Item 2).



B231803320

Figure 7. Sidemarker Harness Bolt.

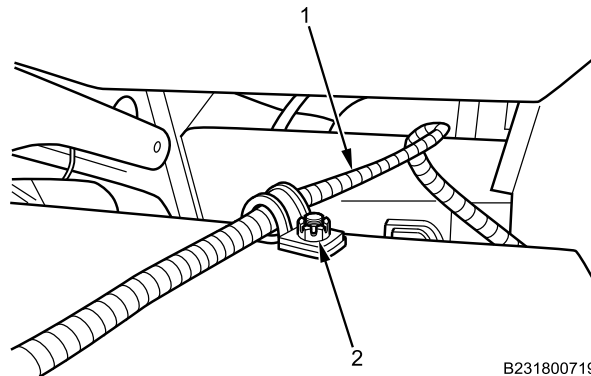

B231800719

Figure 8. Sidemarker Harness Retainer.

END OF TASK**FOLLOW-ON MAINTENANCE**

1. Install 110V cover, outlet, and box (WP 0328).
2. Remove wheel chocks (TM 9-2355-106-10).

END OF TASK**END OF WORK PACKAGE**

FIELD MAINTENANCE

LEFT SIDE FORWARD STOWAGE BOX REMOVAL AND INSTALLATION

INITIAL SETUP:

Tools and Special Tools

General Mechanic's Tool Kit (GMTK)
(WP 0795, Item 37)

Personnel Required

Maintainer - (2)

References

TM 9-2355-106-10
TM 9-2355-106-23P
WP 0786
WP 0782

Equipment Condition

Parking brake set (TM 9-2355-106-10)
Transmission set in NEUTRAL (N) (TM
9-2355-106-10)
Engine off (TM 9-2355-106-10)
MAIN POWER switch off (TM 9-2355-106-10)
Wheels chocked (TM 9-2355-106-10)
Air Conditioning (AC) condenser panel removed
(WP 0672)
Left rear stowage box removed (WP 0676)

REMOVAL

1. Remove three bolts (Figure 1, Item 4) and washers securing left side forward stowage box (Figure 1, Item 2) to body.

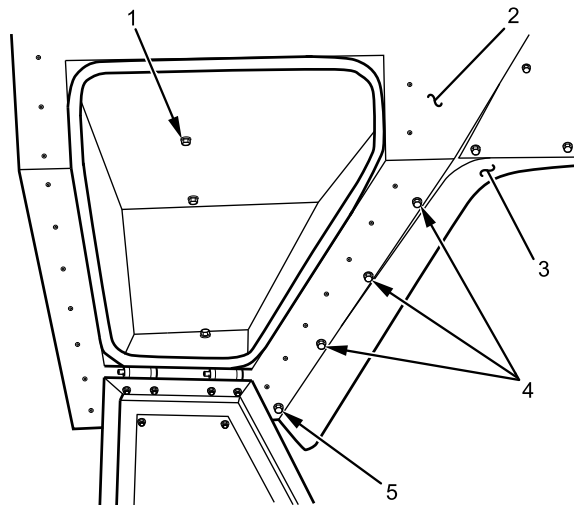

B231803322

Figure 1. Left Side Forward Stowage Box Removal.

2. Remove bolt (Figure 1, Item 5), washer, and nut securing left side forward stowage box (Figure 1, Item 2) to body.
3. With assistant, secure fender (Figure 1, Item 3) and remove six bolts (Figure 1, Item 1) from inside stowage box (Figure 1, Item 2).
4. Remove fender (Figure 1, Item 3).

END OF TASK

LEFT SIDE FORWARD STOWAGE BOX REMOVAL AND INSTALLATION - (CONTINUED)**INSTALLATION**

1. With assistant, position left side forward stowage box (Figure 2, Item 2) to body.

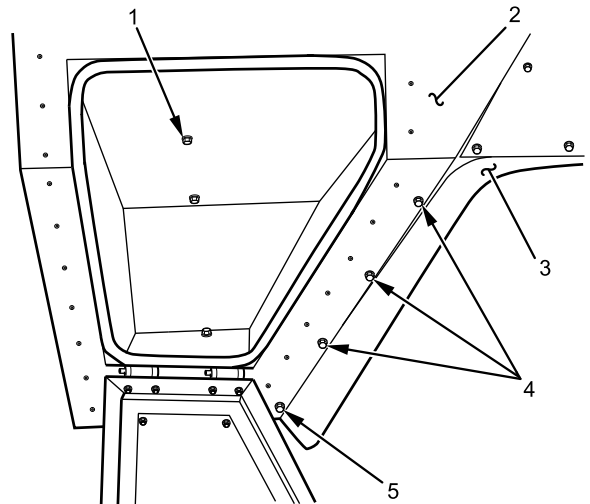

B231803322

Figure 2. Left Side Forward Stowage Box Installation.

2. Loosely install six bolts (Figure 2, Item 1) inside stowage box (Figure 2, Item 2).
3. Position fender (Figure 2, Item 3) on forward stowage box (Figure 2, Item 2).
4. Install three bolts and washers (Figure 2, Item 4) securing left side forward stowage box (Figure 2, Item 2) to body and tighten securely.
5. Install bolt (Figure 2, Item 5), washer, and nut securing left side forward stowage box (Figure 2, Item 2) to body and tighten securely.
6. Tighten six bolts (Figure 2, Item 1) inside stowage box (Figure 2, Item 2) securely.

END OF TASK**FOLLOW-ON MAINTENANCE**

1. Install left rear stowage box (WP 0676).
2. Install AC condenser panel (WP 0672).
3. Remove wheel chocks (TM 9-2355-106-10).

END OF TASK**END OF WORK PACKAGE**

FIELD MAINTENANCE

RIGHT REAR STOWAGE BOX LATCH REMOVAL AND INSTALLATION

INITIAL SETUP:

Tools and Special Tools

General Mechanic's Tool Kit (GMTK)
(WP 0795, Item 37)
Blind rivet tool kit (WP 0795, Item 19)
Bit, drill, standard, cobalt, jobber length, 3/16-inch
(WP 0795, Item 18)
Drill, hand, VSR, electric, 3/8-inch (WP 0795, Item
29)

Materials/Parts

Rivet - (4) (WP 0796, Item 169)

References

TM 9-2355-106-10

TM 9-2355-106-23P

WP 0782

Equipment Condition

Parking brake set (TM 9-2355-106-10)
Transmission set in NEUTRAL (N) (TM
9-2355-106-10)
Engine off (TM 9-2355-106-10)
MAIN POWER switch off (TM 9-2355-106-10)
Wheels chocked (TM 9-2355-106-10)

REMOVAL

1. Drill out rivets (Figure 1, Item 1) securing stowage box latch (Figure 1, Item 2) to stowage box door. Discard rivets.

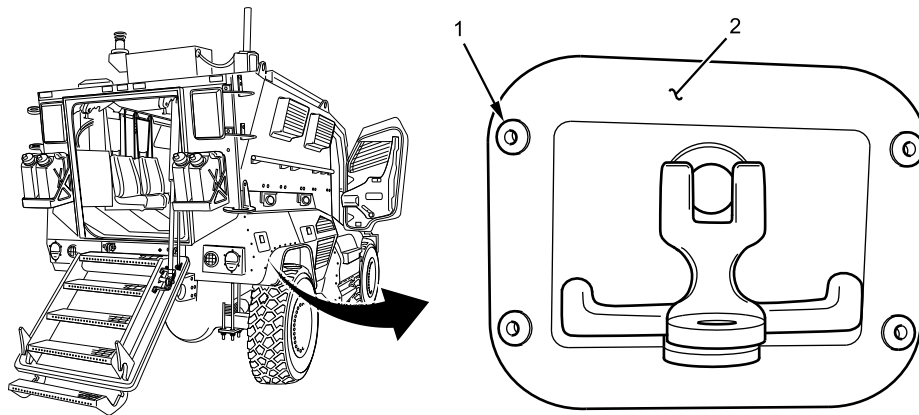

B231810626

Figure 1. Stowage Box Latch Removal.

2. Remove stowage box latch and gasket (Figure 1, Item 2) from door.

END OF TASK

RIGHT REAR STOWAGE BOX LATCH REMOVAL AND INSTALLATION - (CONTINUED)**INSTALLATION**

1. Position stowage box latch and gasket (Figure 2, Item 2) to stowage box door.

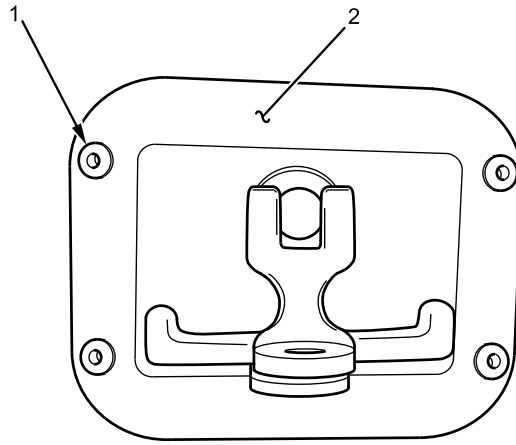

B232201403

Figure 2. Stowage Box Latch Installation.

2. Install four new rivets (Figure 2, Item 1) securing latch (Figure 2, Item 2) to stowage box door.

END OF TASK**FOLLOW-ON MAINTENANCE**

1. Remove wheel chocks (TM 9-2355-106-10).

END OF TASK**END OF WORK PACKAGE**

FIELD MAINTENANCE

LEFT REAR STOWAGE BOX REMOVAL AND INSTALLATION

INITIAL SETUP:

Tools and Special Tools

General Mechanic's Tool Kit (GMTK)
(WP 0795, Item 37)

WP 0786

WP 0782

Materials/Parts

Gloves (WP 0794, Item 18)
Grease (WP 0794, Item 22)

Equipment Condition

Parking brake set (TM 9-2355-106-10)

Transmission set in NEUTRAL (N) (TM 9-2355-106-10)

Engine off (TM 9-2355-106-10)

MAIN POWER switch off (TM 9-2355-106-10)

Wheels chocked (TM 9-2355-106-10)

References

TM 9-2355-106-10

TM 9-2355-106-23P

REMOVAL

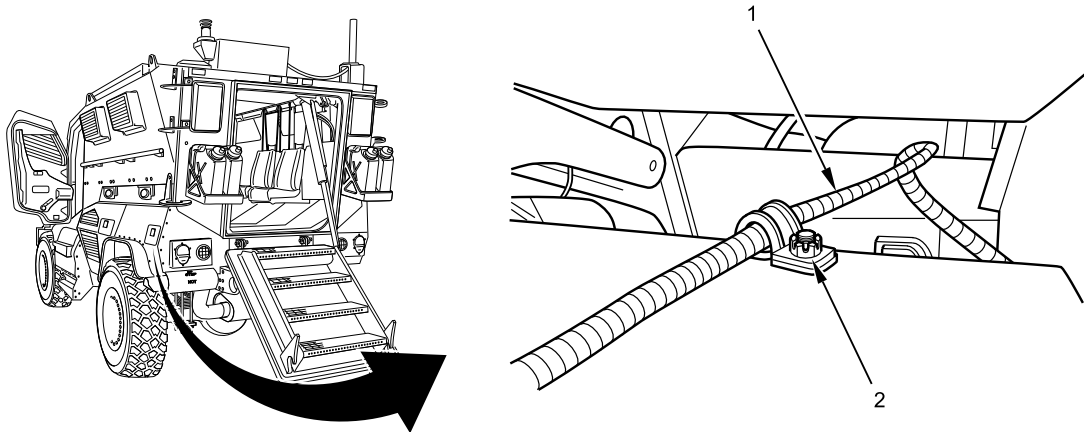

B231810624

Figure 1. Left Rear Stowage Box Removal.

1. Remove nut (Figure 1, Item 2) and bolt securing sidemarker light harness (Figure 1, Item 1) on backside of stowage bin. Bolt located inside of stowage box not shown.

LEFT REAR STOWAGE BOX REMOVAL AND INSTALLATION - (CONTINUED)

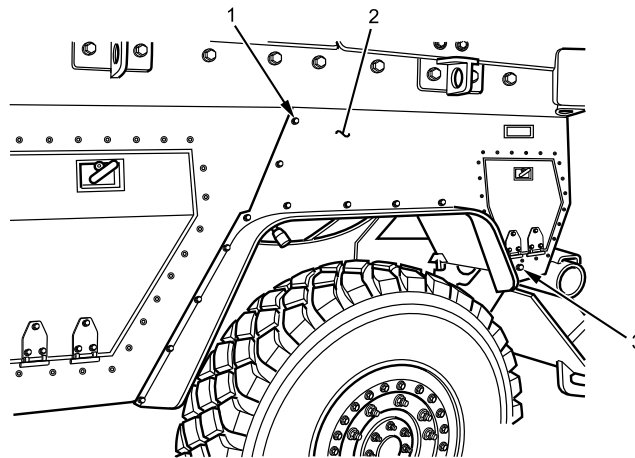

B231803366

Figure 2. Left Rear Stowage Box Removal.

2. Remove bolt (Figure 2, Item 3), flat washer, and nut from stowage box (Figure 2, Item 2). Nut located inside stowage box not shown.
3. Remove 16 bolts (Figure 2, Item 1) and flat washers from stowage box (Figure 2, Item 2).

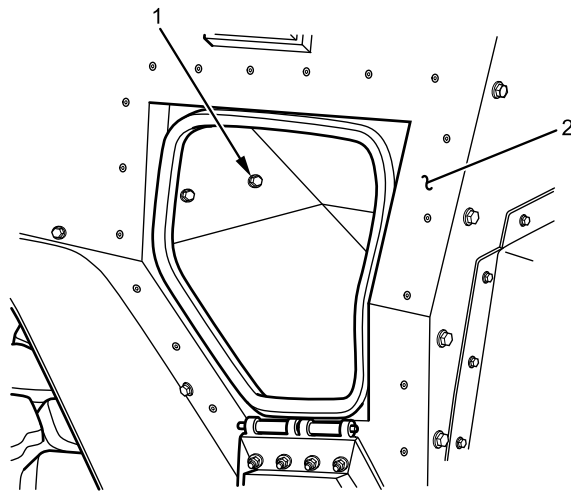

B231800727

Figure 3. Left Rear Stowage Box Inside Bolts.

4. Remove four bolts (Figure 3, Item 1) securing left rear stowage box (Figure 3, Item 2) to body from inside box. Two bolts not shown.

LEFT REAR STOWAGE BOX REMOVAL AND INSTALLATION - (CONTINUED)

Figure 4. Sidemarker Wiring.

5. Pull left rear stowage box away from body and disconnect positive wire (Figure 4, Item 3) from sidemarker light.
6. Remove nut (Figure 4, Item 2) securing ground wires (Figure 4, Item 1).
7. Remove left rear stowage box.

END OF TASK

LEFT REAR STOWAGE BOX REMOVAL AND INSTALLATION - (CONTINUED)**INSTALLATION****WARNING**

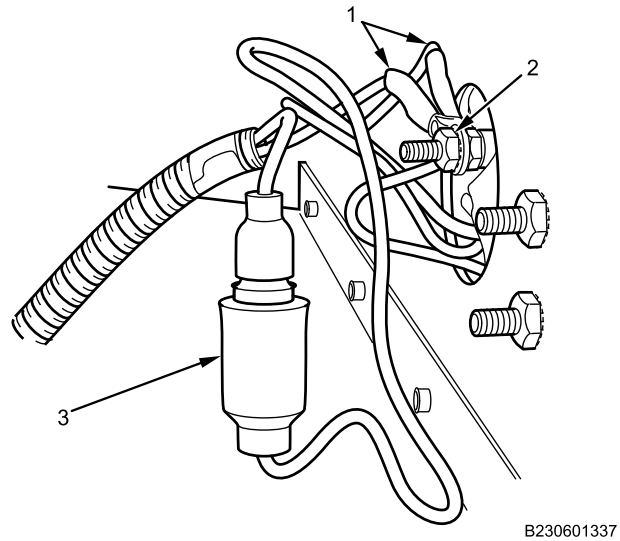
Dielectric grease is harmful to skin and eyes. If grease contacts eyes, rinse thoroughly and contact physician if irritation persists. If skin is contacted, wash thoroughly with soap and water. Failure to comply may result in serious injury to personnel.

NOTE

Apply dielectric grease to all electrical connections.

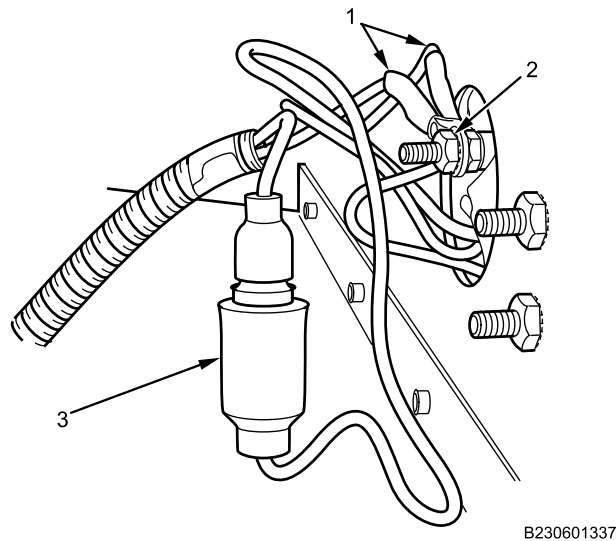

Figure 5. Sidemarker Wiring.

1. Position left rear stowage box on body.
2. Connect positive wire (Figure 5, Item 3) to sidemarker light.
3. Position ground wires (Figure 5, Item 1) and install nut (Figure 5, Item 2) and tighten securely.

LEFT REAR STOWAGE BOX REMOVAL AND INSTALLATION - (CONTINUED)

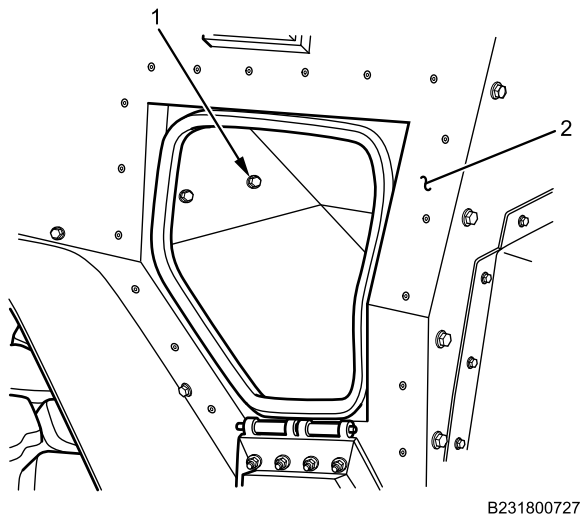

Figure 6. Left Rear Stowage Box Inside Bolts.

4. Align left rear stowage box (Figure 6, Item 2) to body.
5. Loosely install four bolts (Figure 6, Item 1) securing left rear stowage box (Figure 6, Item 2). Two bolts not shown.

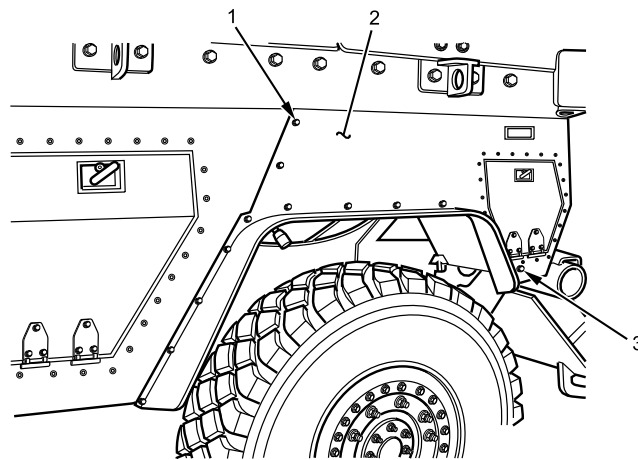

Figure 7. Left Rear Stowage Box Installation.

6. Install 16 bolts (Figure 7, Item 1) and flat washers securing left rear stowage box (Figure 7, Item 2) to body and tighten securely.
7. Install one bolt (Figure 7, Item 3), flat washer, and nut and tighten securely. Nut located inside stowage box not shown.
8. Tighten four bolts (Figure 7, Item 1) inside stowage box (Figure 7, Item 2) securely.

LEFT REAR STOWAGE BOX REMOVAL AND INSTALLATION - (CONTINUED)

Figure 8. Sidemarker Harness Retainer.

9. Install nut (Figure 8, Item 2) and bolt securing sidemarker light harness (Figure 8, Item 1) to backside of stowage bin. Bolt located inside of stowage box not shown.

END OF TASK

FOLLOW-ON MAINTENANCE

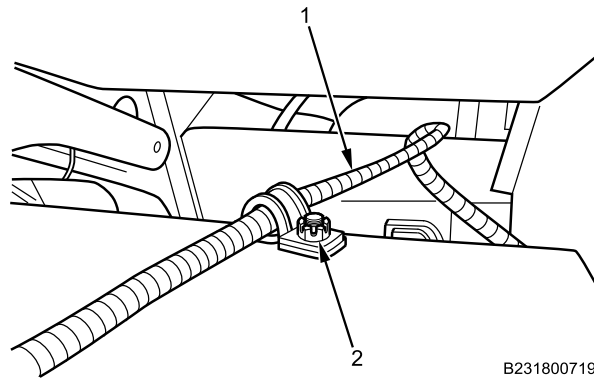
1. Remove wheel chocks (TM 9-2355-106-10).

END OF TASK

END OF WORK PACKAGE

FIELD MAINTENANCE
WINCH CABLE REMOVAL AND INSTALLATION

INITIAL SETUP:**Tools and Special Tools**

General Mechanic's Tool Kit (GMTK)
(WP 0795, Item 37)
Gloves, rubber (WP 0795, Item 38)
Wrench, torque, 40-200 in-lb, 3/8-in drive
(WP 0795, Item 142)

TM 9-2355-106-23P

WP 0786

WP 0782

Equipment Condition

Parking brake set (TM 9-2355-106-10)
Transmission set in NEUTRAL (N) (TM
9-2355-106-10)

Engine off (TM 9-2355-106-10)

MAIN POWER switch off (TM 9-2355-106-10)

Wheels chocked (TM 9-2355-106-10)

Winch remote control installed (TM 9-2355-106-10)

Materials/Parts

Compound (WP 0794, Item 13)
Gloves (WP 0794, Item 19)

Personnel Required

Maintainer - (2)

References

TM 9-2355-106-10

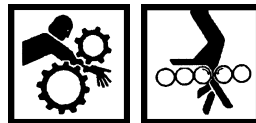
WARNING

Before removing winch cable from vehicle, check cable for damage such as frayed wires, binds, or kinks. If found, replace cable. Failure to comply may result in damage to equipment and serious injury or death to personnel.

Cable is under tension when installed. Wear safety goggles and work gloves when handling. Do not wear loose clothing; it can get caught in cable as cable winds around spool drum. Failure to comply may result in serious injury or death to personnel.

When operating winch, ensure there are no objects in path of cable or vehicle. Failure to comply may result in damage to equipment and serious injury or death to personnel.

Wear heavy, leather-palmed work gloves when handling cable. Never let moving cable slide through hands, even when wearing gloves. Cable can become frayed or contain broken wires. A broken wire could cut through gloves and injure hands. Failure to comply can result in serious injury to personnel.

WINCH CABLE REMOVAL AND INSTALLATION - (CONTINUED)**REMOVAL**

1. Using a punch and hammer, remove pin (Figure 1, Item 4), coupler (Figure 1, Item 2), and hook (Figure 1, Item 3) from winch cable (Figure 1, Item 1).

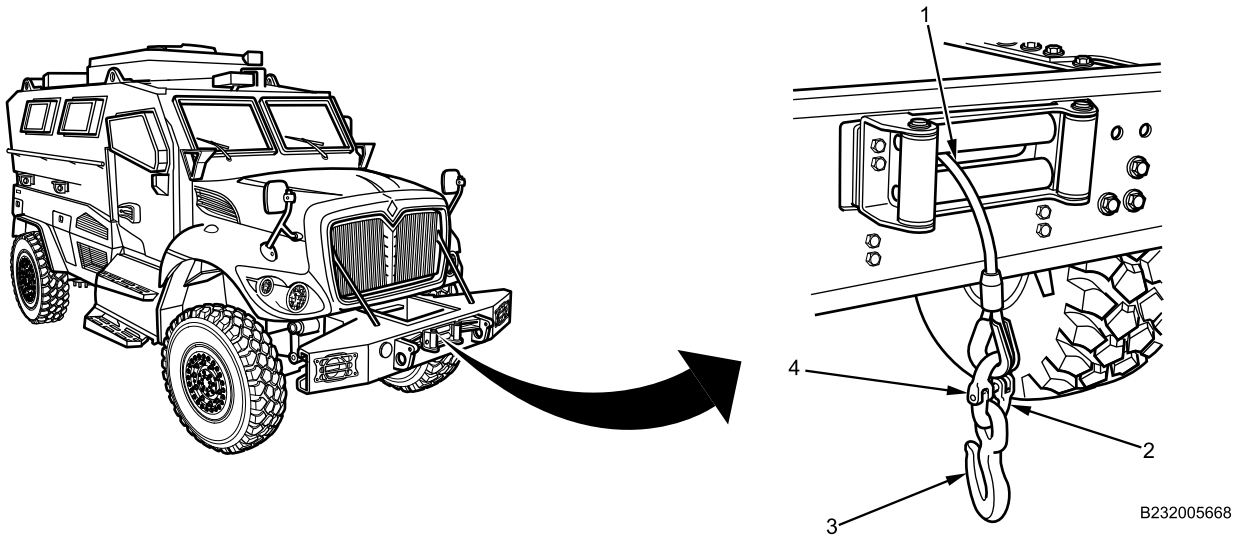

Figure 1. Hook and Coupler.

2. Turn MAIN POWER switch on and start engine.
3. Using assistant, activate winch with remote control and start paying out cable (Figure 1, Item 1), retaining tension on cable until completely extended.
4. Stop winch, turn engine off, and turn MAIN POWER switch off.
5. Align drum spool to access setscrew (Figure 2, Item 1), remove setscrew (Figure 2, Item 1) and winch cable (Figure 2, Item 2) from drum spool (Figure 2, Item 3).

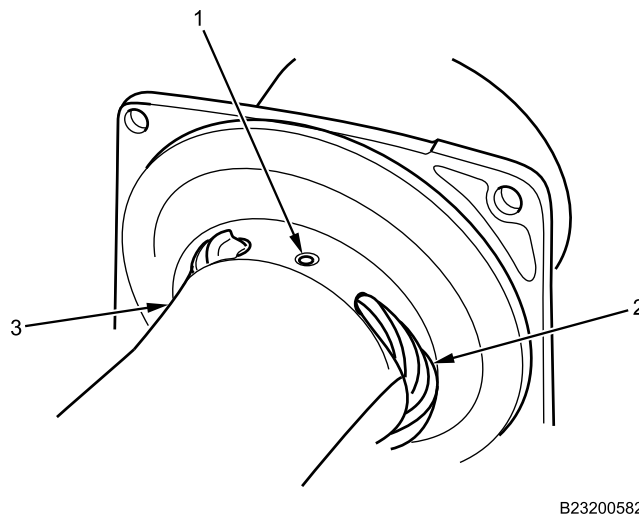

Figure 2. Winch Cable and Drum.

END OF TASK

WINCH CABLE REMOVAL AND INSTALLATION - (CONTINUED)**INSTALLATION****WARNING**

Corrosion preventive compound is toxic. Use only in well-ventilated area. Do not get in eyes; wear chemical safety goggles and full-face shield when using. Avoid contact with skin and wear rubber or plastic, solvent-resistant gloves. In case of contact, remove contaminated clothing and immediately wash area with soap and water. If compound contacts eyes, flush eyes with large amounts of water for at least 15 minutes and get immediate medical attention. If swallowed, do not induce vomiting; contact a physician immediately. Failure to comply may result in serious injury or death to personnel.

1. Apply corrosion preventive compound on setscrew threads.

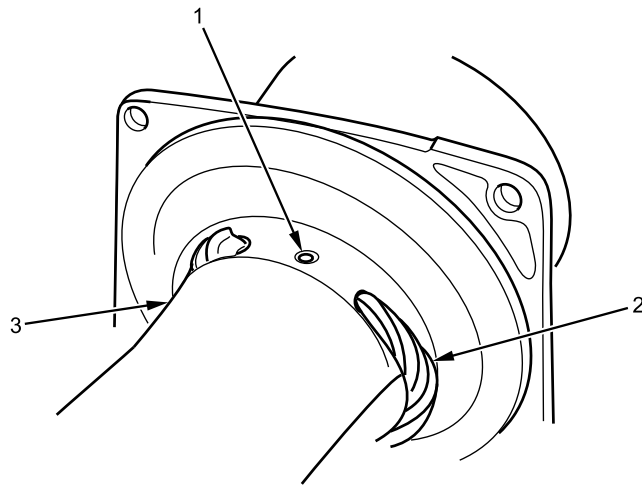

B232005829

Figure 3. Winch Cable and Drum.

2. Apply corrosion preventive compound on drum spool (Figure 3, Item 3).
3. Install winch cable (Figure 3, Item 2) on drum spool (Figure 3, Item 3) with setscrew (Figure 3, Item 1). Torque to 12-15 lb-ft (16-20 N•m).

WINCH CABLE REMOVAL AND INSTALLATION - (CONTINUED)

4. Using a hammer and punch, install coupler (Figure 4, Item 2) and hook (Figure 4, Item 3) on winch cable (Figure 4, Item 1) with pin (Figure 4, Item 4).

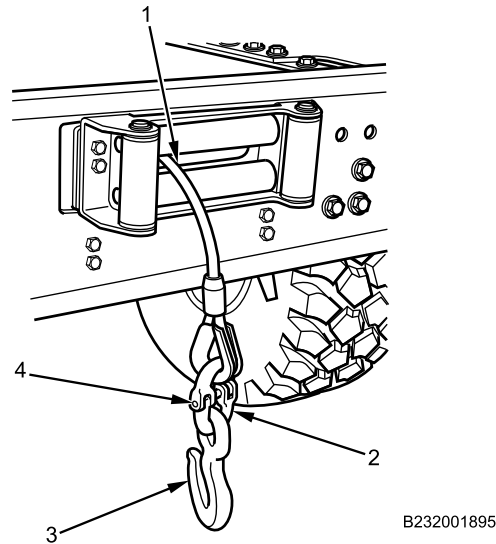

Figure 4. Hook and Coupler.

5. Turn MAIN POWER switch on and start engine.

WARNING

When installing new cable, ensure cable is free of kinks, binds, and frayed wires before installing onto drum spool. Secure new cable to spool drum with screws. Always prestretch cable and respool under load before use. Tightly wound cable reduces chances of binding. Failure to comply may result in damage to equipment and serious injury or death to personnel.

6. With assistant, start paying in winch cable (Figure 4, Item 1) evenly on drum spool, retaining tension on winch cable until completely installed.
7. Stop winch, turn engine off.

END OF TASK**FOLLOW-ON MAINTENANCE**

1. Winch remote control removed (TM 9-2355-106-10).
2. Turn MAIN POWER switch off (TM 9-2355-106-10).
3. Remove wheel chocks (TM 9-2355-106-10).

END OF TASK**END OF WORK PACKAGE**

FIELD MAINTENANCE

WINCH ASSEMBLY REMOVAL AND INSTALLATION

INITIAL SETUP:

Tools and Special Tools

General Mechanic's Tool Kit (GMTK)
(WP 0795, Item 37)
Belly Armor Removal/Installer Kit (WP 0795, Item 16)
Gloves, rubber (WP 0795, Item 38)
Lifting device (WP 0795, Item 67)
Sling, nylon (WP 0795, Item 91)
Wrench, torque, 20-100 lb-ft, 3/8-inch drive
(WP 0795, Item 141)

Materials/Parts

Compound (WP 0794, Item 13)
Faceshield, industrial (WP 0794, Item 16)
Gloves (WP 0794, Item 19)
Goggles, industrial (WP 0794, Item 20)
Grease (WP 0794, Item 22)
Lockwasher - (2) (WP 0796, Item 24)
Cable lock strap - (3) (WP 0796, Item 124)

Personnel Required

Maintainer - (2)

References

TM 9-2355-106-10
TM 9-2355-106-23P
WP 0782

Equipment Condition

Parking brake set (TM 9-2355-106-10)
Transmission set in NEUTRAL (N) (TM 9-2355-106-10)
Engine off (TM 9-2355-106-10)
MAIN POWER switch off (TM 9-2355-106-10)
Wheels chocked (TM 9-2355-106-10)
Batteries disconnected (WP 0404)
Winch remote control connector support removed
(WP 0545)

WARNING



Use extreme caution when testing or working on or around electrical circuits. Always assume that electrical circuits are live. Electrical shock can occur upon contact with voltage high enough to cause current flow through muscles or nerves. On Direct Current (DC) systems, generally 1 milliamp of current can be felt, 5 milliamps can cause severe pain, 15 milliamps can cause loss of muscle control, and 70 milliamps can be fatal. Wear protective clothing; ensure skin, clothing, and surrounding areas are dry; do not wear jewelry; and touch only the insulated, nonmetallic parts of electrical components and testing equipment. To prevent electrical arcing, avoid shorting electrical test probes and jumper wires. Electrical arcing can cause bright flashes of light, capable of causing temporary blindness. If electrical injury occurs, immediately shut off power supply and seek medical assistance. Failure to comply may result in serious injury or death to personnel.

Winch is extremely heavy. Use an assistant and lifting device to remove and install onto front of vehicle. Wear safety goggles and work gloves when removing and installing. Failure to comply may result in damage to equipment and serious injury or death to personnel.

WINCH ASSEMBLY REMOVAL AND INSTALLATION - (CONTINUED)

REMOVAL

1. Remove all cable lock straps (Figure 1, Item 1) from winch assembly power and ground cables. Discard cable lock straps.

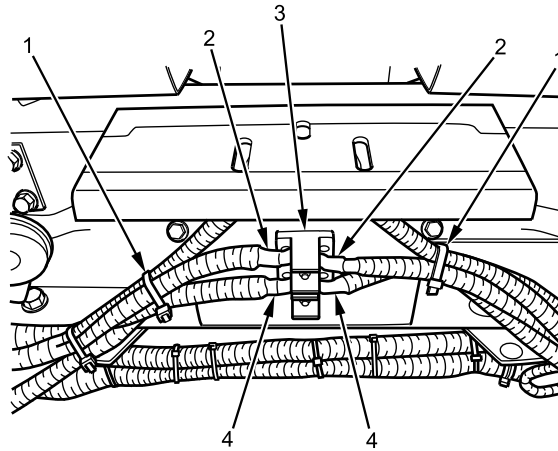

B232001674

Figure 1. Junction Block.

2. Remove nut, lockwasher, and winch assembly BLACK ground cable (Figure 1, Item 3) from junction block (Figure 1, Item 4). Discard lockwasher.
3. Remove nut, lockwasher, and winch assembly RED power cable (Figure 1, Item 2) from junction block (Figure 1, Item 4). Discard lockwasher.
4. Remove cable lock strap (Figure 2, Item 2) from winch harness support (Figure 2, Item 1). Discard cable lock strap.

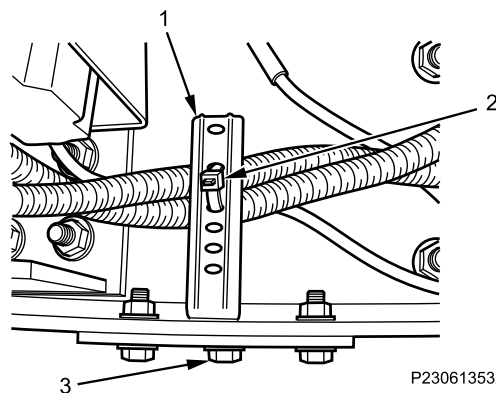

P230613532

Figure 2. Winch Harness Support.

5. Remove nut, washer and bolt (Figure 2, Item 3) from winch harness support (Figure 2, Item 1). Remove harness support.

WINCH ASSEMBLY REMOVAL AND INSTALLATION - (CONTINUED)

6. Remove pin (Figure 3, Item 4), coupler (Figure 3, Item 2), and hook (Figure 3, Item 3) from cable (Figure 3, Item 1).

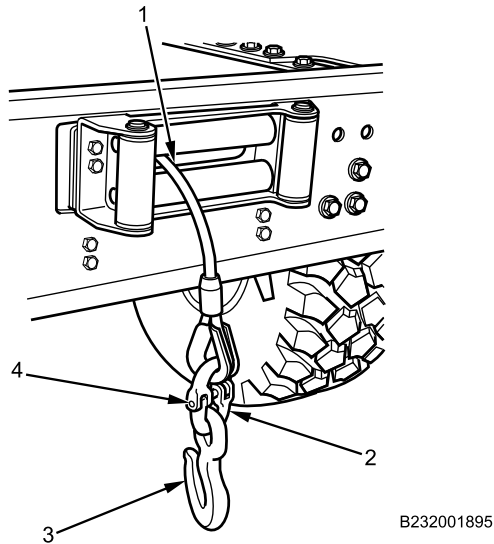

Figure 3. Hook and Coupler.

7. Remove four bolts (Figure 4, Item 4) securing winch carrier (Figure 4, Item 1) to front frame crossmember assembly (Figure 4, Item 3), and remove winch carrier (Figure 4, Item 1) from cable (Figure 4, Item 2).

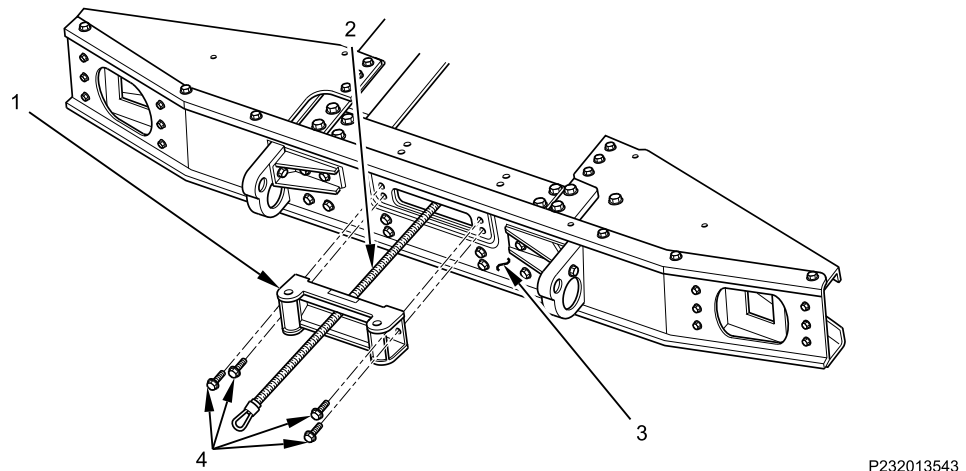
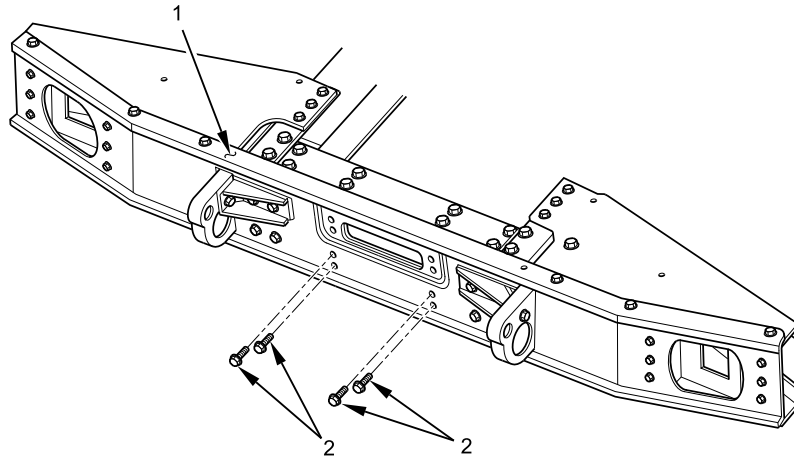

Figure 4. Winch Carrier Removal.

WINCH ASSEMBLY REMOVAL AND INSTALLATION - (CONTINUED)



P230613530

Figure 5. Front Crossmember Bolts.

8. Remove four lower bolts (Figure 5, Item 2) from front bumper crossmember assembly (Figure 5, Item 1).
9. Secure two lifting slings onto winch assembly (Figure 6, Item 2) and attach slings on lifting device.

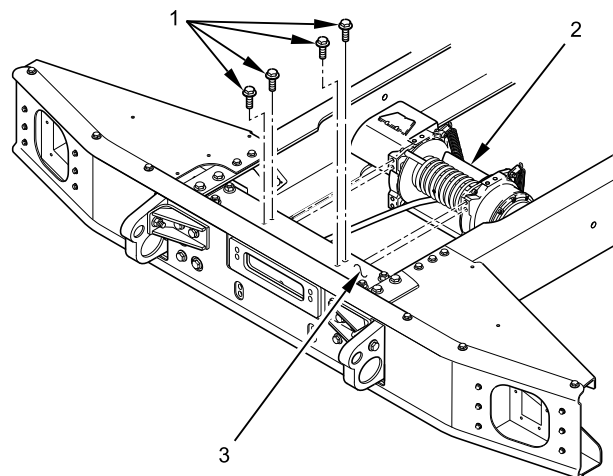

P230613531

Figure 6. Winch Assembly Removal.

10. Retain tension on slings while removing winch assembly.
11. With maintainer assistance, remove four bolts (Figure 6, Item 1) and winch assembly (Figure 6, Item 2) from front top frame of crossmember assembly (Figure 6, Item 3).

END OF TASK

WINCH ASSEMBLY REMOVAL AND INSTALLATION - (CONTINUED)**INSTALLATION****WARNING**

Corrosion preventive compound is toxic. Use only in well-ventilated area. Do not get in eyes; wear chemical safety goggles and full-face shield when using. Avoid contact with skin and wear rubber or plastic, solvent-resistant gloves. In case of contact, remove contaminated clothing and immediately wash area with soap and water. If compound contacts eyes, flush eyes with large amounts of water for at least 15 minutes and get immediate medical attention. If swallowed, do not induce vomiting; contact a physician immediately. Failure to comply may result in serious injury or death to personnel.

Dielectric grease is harmful to skin and eyes. If grease contacts eyes, rinse thoroughly and contact physician if irritation persists. If skin is contacted, wash thoroughly with soap and water. Failure to comply may result in serious injury to personnel.

NOTE

Apply corrosion preventive compound on all winch assembly bolt threads.

Apply dielectric grease to all electrical connections before installation.

1. With maintainer assistance, secure two lifting slings onto winch assembly (Figure 7, Item 2) and attach slings to lifting device.

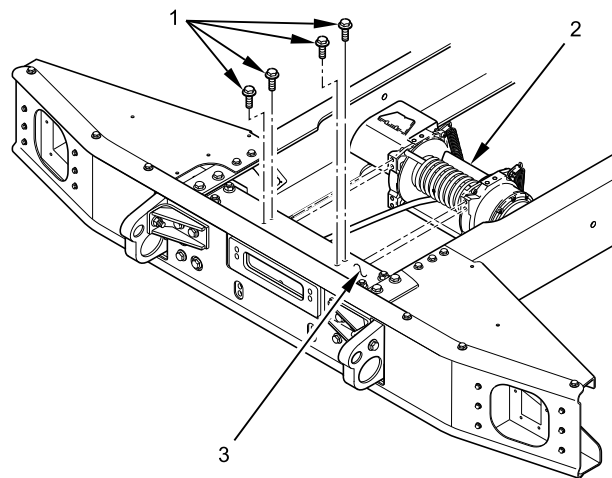

P230613531

Figure 7. Winch Assembly Installation.

2. Retain tension on slings while installing winch assembly.
3. Install winch assembly (Figure 7, Item 2) on front top frame of crossmember assembly (Figure 7, Item 3) with four bolts (Figure 7, Item 1). Do not tighten.

WINCH ASSEMBLY REMOVAL AND INSTALLATION - (CONTINUED)

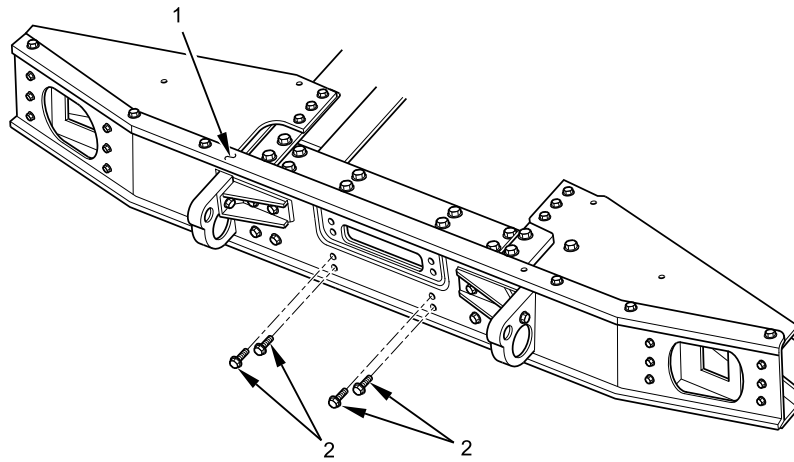

P230613530

Figure 8. Front Crossmember Bolt Installation.

4. Install four bolts (Figure 8, Item 2) through front bumper crossmember assembly (Figure 8, Item 1) into winch assembly. Do not tighten.
5. Remove sling and lifting device.
6. Insert cable (Figure 9, Item 2) through winch carrier (Figure 9, Item 1) and install winch carrier on front frame crossmember assembly (Figure 9, Item 3) with four bolts (Figure 9, Item 4). Tighten all bolts securely.

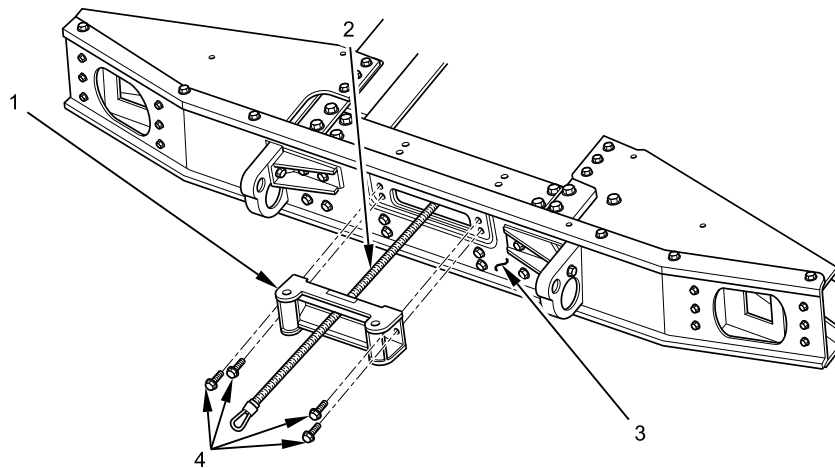

P232013543

Figure 9. Winch Carrier Installation.

WINCH ASSEMBLY REMOVAL AND INSTALLATION - (CONTINUED)

7. Install coupler (Figure 10, Item 2) and hook (Figure 10, Item 3) onto cable (Figure 10, Item 1) with pin (Figure 10, Item 4).

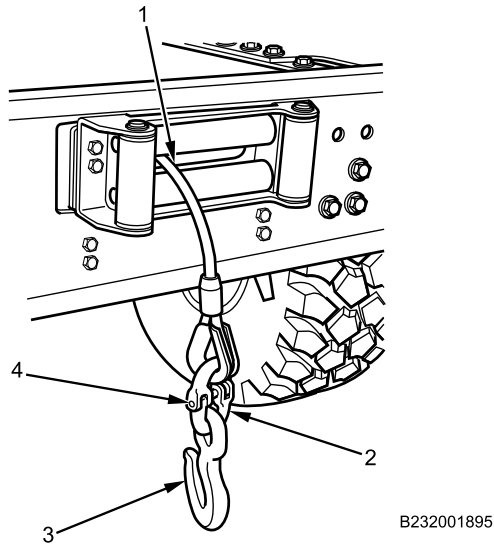

Figure 10. Hook and Coupler.

8. Install new cable lock strap (Figure 11, Item 2) on winch harness support (Figure 11, Item 1).

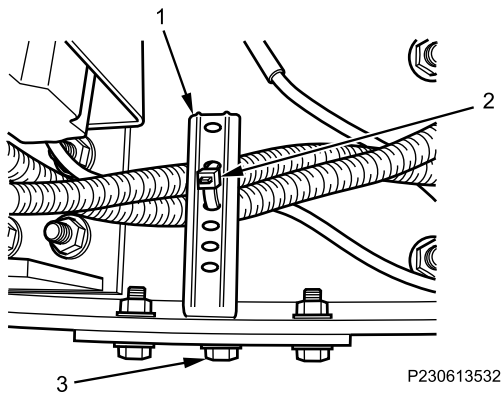
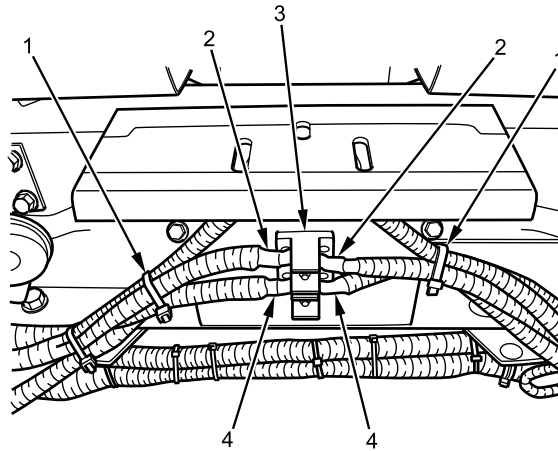

Figure 11. Winch Harness Support.

WINCH ASSEMBLY REMOVAL AND INSTALLATION - (CONTINUED)

9. Install winch assembly RED power cable (Figure 12, Item 2) on junction block (Figure 12, Item 4) with new lockwasher and nut. Tighten and secure.



B232001674

Figure 12. Junction Block.

10. Install winch assembly BLACK ground cable (Figure , Item 3) on junction block (Figure 12, Item 4) with new lockwasher and nut. Tighten and secure.
11. Position winch assembly power and ground cables (Figure 12, Item 2 and 3) and secure with new cable lock straps (Figure 12, Item 1).

END OF TASK**FOLLOW-ON MAINTENANCE**

1. Install winch remote control connector support (WP 0545).
2. Connect batteries (WP 0404).
3. Turn MAIN POWER switch on (TM 9-2355-106-10).
4. Start engine (TM 9-2355-106-10).
5. Verify winch operation (TM 9-2355-106-10).
6. Turn engine off (TM 9-2355-106-10).
7. Remove wheel chocks (TM 9-2355-106-10).

END OF TASK**END OF WORK PACKAGE**

FIELD MAINTENANCE**LITTER ARM STORAGE BRACKET REMOVAL AND INSTALLATION**

INITIAL SETUP:**Tools and Special Tools**

General Mechanic's Tool Kit (GMTK)
(WP 0795, Item 37)

WP 0786

WP 0782

Materials/Parts

Compound (WP 0794, Item 13)
Faceshield, industrial (WP 0794, Item 16)
Gloves (WP 0794, Item 18)
Goggles, industrial (WP 0794, Item 20)

Equipment Condition

Parking brake set (TM 9-2355-106-10)
Transmission set in NEUTRAL (N) (TM
9-2355-106-10)
Engine off (TM 9-2355-106-10)
MAIN POWER switch off (TM 9-2355-106-10)
Wheels chocked (TM 9-2355-106-10)
Rear door/ramp open and secured (TM
9-2355-106-10)

References

TM 9-2355-106-10
TM 9-2355-106-23P

NOTE

Litter arms and storage bracket are located underneath the left rear seats.

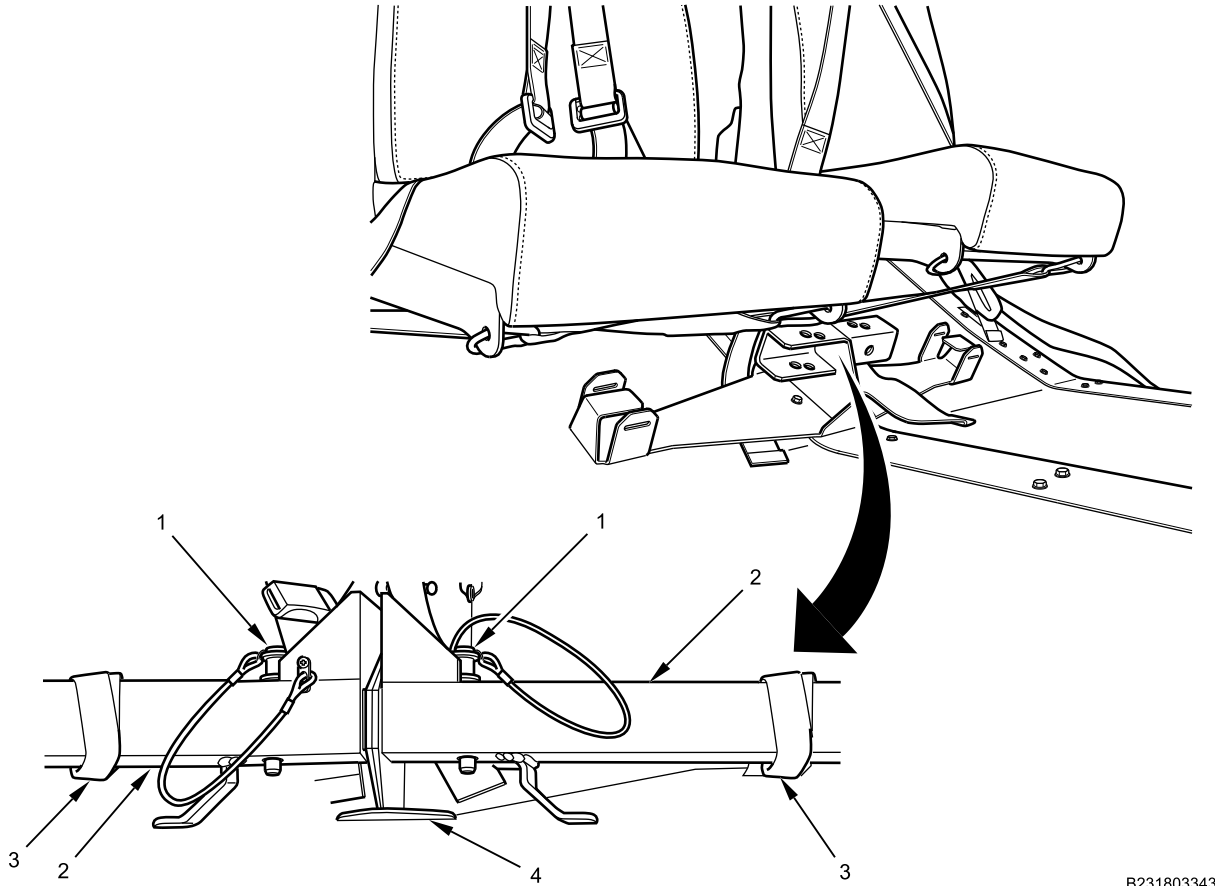
LITTER ARM STORAGE BRACKET REMOVAL AND INSTALLATION - (CONTINUED)**REMOVAL**

B231803343

Figure 1. Litter Arms.

1. Remove two pins (Figure 1, Item 1), two straps (Figure 1, Item 3), and two litter arms (Figure 1, Item 2) from litter arm storage bracket (Figure 1, Item 4).

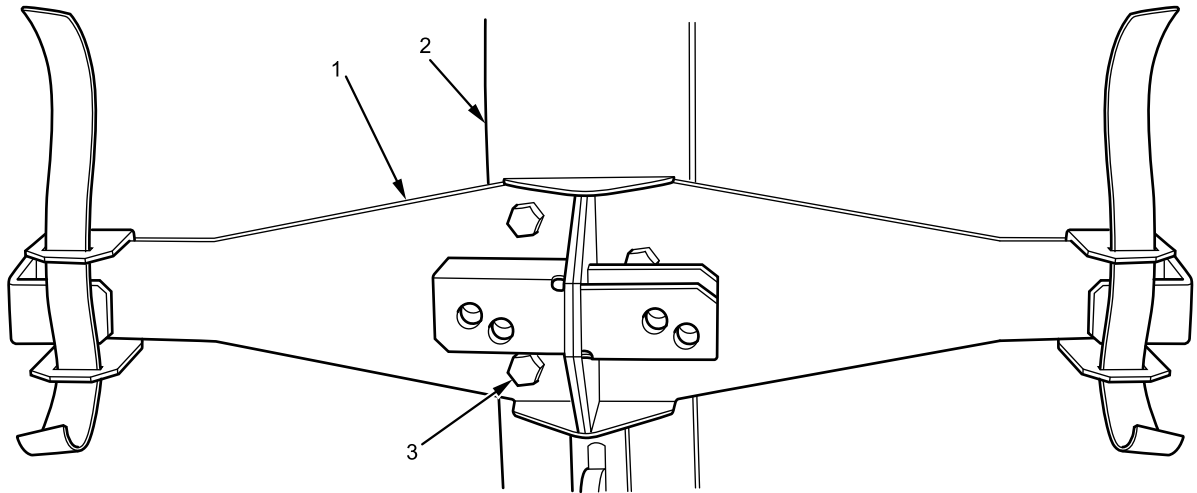
LITTER ARM STORAGE BRACKET REMOVAL AND INSTALLATION - (CONTINUED)

B231800703

Figure 2. Litter Arm Storage Bracket.

NOTE

Three bolts shown. One bolt hidden from view.

2. Remove four bolts (Figure 2, Item 3), four washers, and litter arm storage bracket (Figure 2, Item 1) from floor (Figure 2, Item 2).

END OF TASK

LITTER ARM STORAGE BRACKET REMOVAL AND INSTALLATION - (CONTINUED)

INSTALLATION

WARNING



Corrosion preventive compound is toxic. Use only in well-ventilated area. Do not get in eyes; wear chemical safety goggles and full-face shield when using. Avoid contact with skin and wear rubber or plastic, solvent-resistant gloves. In case of contact, remove contaminated clothing and immediately wash area with soap and water. If compound contacts eyes, flush eyes with large amounts of water for at least 15 minutes and get immediate medical attention. If swallowed, do not induce vomiting; contact a physician immediately. Failure to comply may result in serious injury or death to personnel.

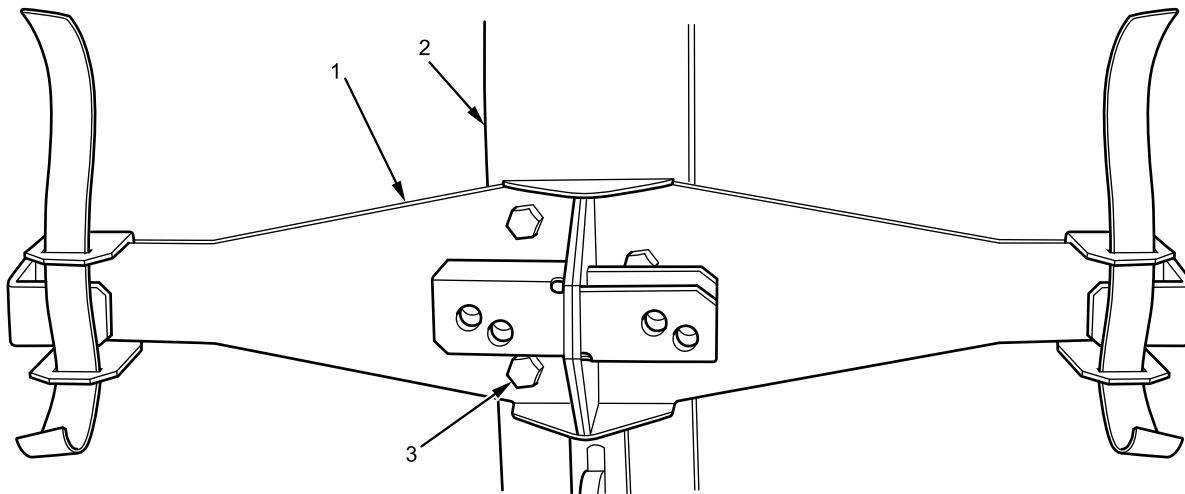

B231800703

Figure 3. Litter Arm Storage Bracket.

1. Apply corrosion preventive compound on litter arm storage bracket bolt threads.
2. Install litter arm storage bracket (Figure 3, Item 1) on floor (Figure 3, Item 2) with four washers and four bolts (Figure 3, Item 3). Tighten bolts securely.

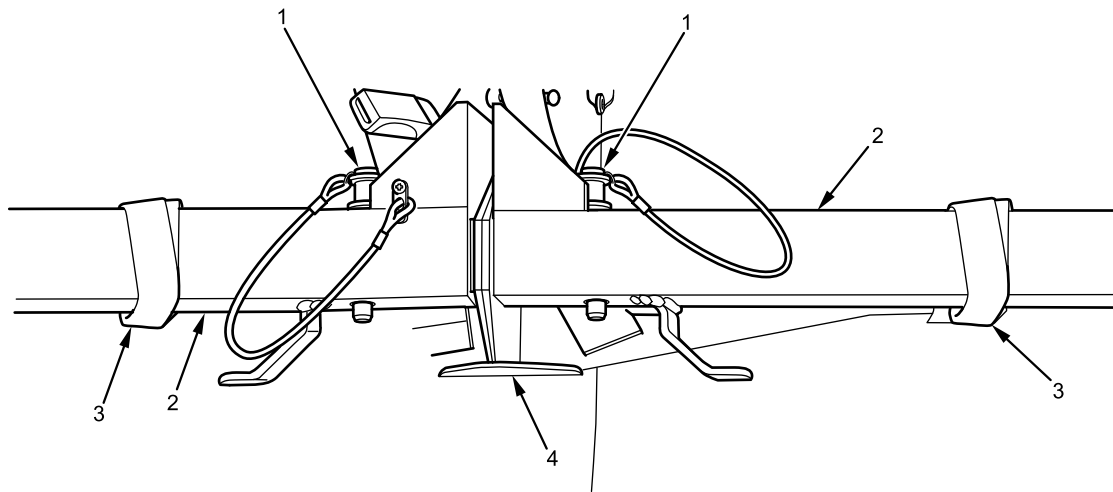
LITTER ARM STORAGE BRACKET REMOVAL AND INSTALLATION - (CONTINUED)

B231800702

Figure 4. Litter Arms.

3. Install two litter arms (Figure 4, Item 2) on litter arm storage bracket (Figure 4, Item 4) with two pins (Figure 4, Item 1) and two straps (Figure 4, Item 3).

END OF TASK**FOLLOW-ON MAINTENANCE**

1. Close and secure rear door/ramp (TM 9-2355-106-10).
2. Remove wheel chocks (TM 9-2355-106-10).

END OF TASK**END OF WORK PACKAGE**

FIELD MAINTENANCE

FRONT LITTER ARM MOUNT PLATE AND ARM SUPPORT REMOVAL AND INSTALLATION

INITIAL SETUP:

Tools and Special Tools

General Mechanic's Tool Kit (GMTK)
(WP 0795, Item 37)

TM 9-2355-106-23P

WP 0786

WP 0782

Materials/Parts

Compound (WP 0794, Item 13)
Goggles, industrial (WP 0794, Item 20)
Faceshield, industrial (WP 0794, Item 16)
Gloves (WP 0794, Item 18)

Equipment Condition

Parking brake set (TM 9-2355-106-10)
Transmission set in NEUTRAL (N) (TM 9-2355-106-10)
Engine off (TM 9-2355-106-10)
MAIN POWER switch off (TM 9-2355-106-10)
Wheels chocked (TM 9-2355-106-10)
Rear door/ramp open (TM 9-2355-106-10)

References

TM 9-2355-106-10

NOTE

Note orientation of front litter arm mount plate and arm support to aid in installation.

REMOVAL

1. Remove 11 bolts (Figure 1, Item 3), front litter arm mount plate, and arm support (Figure 1, Item 2) from wall (Figure 1, Item 1).

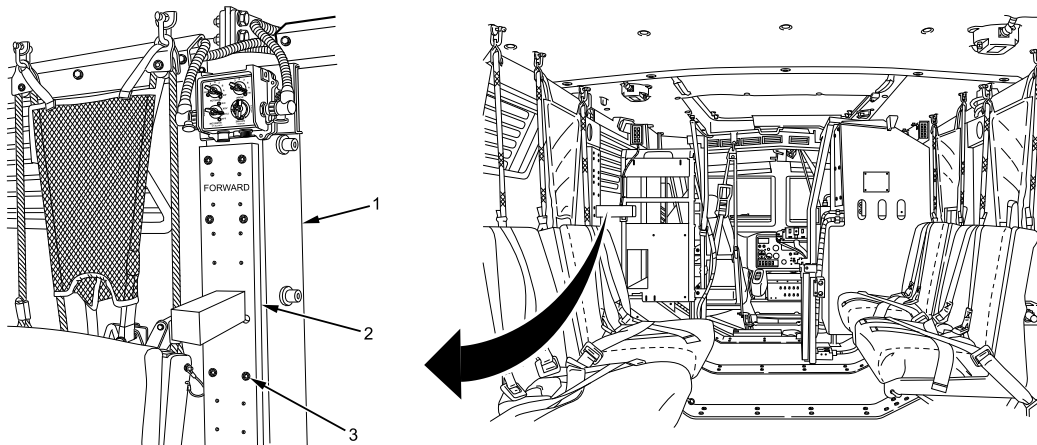

B231810657

Figure 1. Front Litter Arm Mount Plate.

FRONT LITTER ARM MOUNT PLATE AND ARM SUPPORT REMOVAL AND INSTALLATION - (CONTINUED)

- Remove two bolts (Figure 2, Item 2) and arm support (Figure 2, Item 1) from front litter arm mount plate (Figure 2, Item 3).

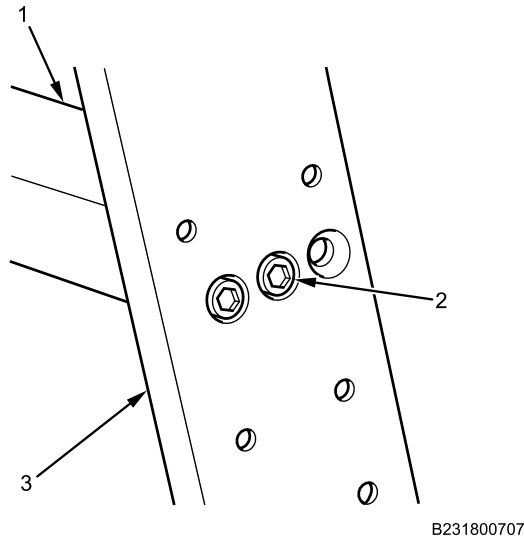

Figure 2. Arm Support.

END OF TASK

INSTALLATION

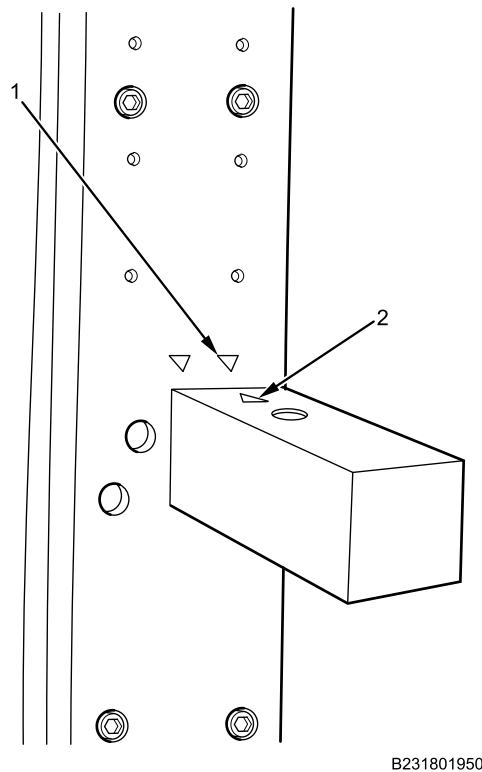

Figure 3. Die Mark.

- Align arm support die mark (Figure 3, Item 2) with front litter arm mount plate right die mark (Figure 3, Item 1).

FRONT LITTER ARM MOUNT PLATE AND ARM SUPPORT REMOVAL AND INSTALLATION - (CONTINUED)

WARNING

Corrosion preventive compound is toxic. Use only in well-ventilated area. Do not get in eyes; wear chemical safety goggles and full-face shield when using. Avoid contact with skin and wear rubber or plastic, solvent-resistant gloves. In case of contact, remove contaminated clothing and immediately wash area with soap and water. If compound contacts eyes, flush eyes with large amounts of water for at least 15 minutes and get immediate medical attention. If swallowed, do not induce vomiting; contact a physician immediately. Failure to comply may result in serious injury or death to personnel.

2. Apply corrosion preventive compound on front litter arm mount plate bolt and arm support bolt threads.

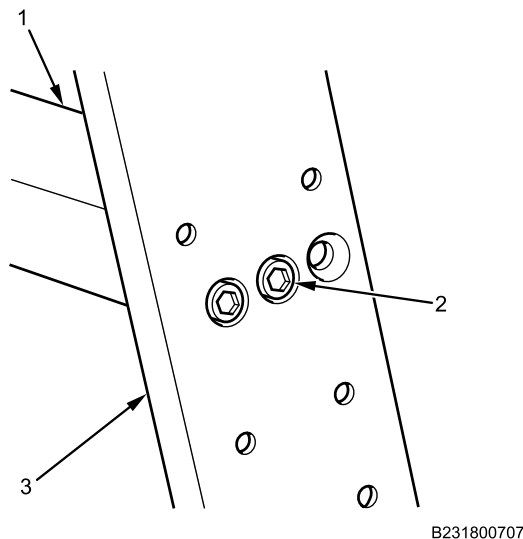
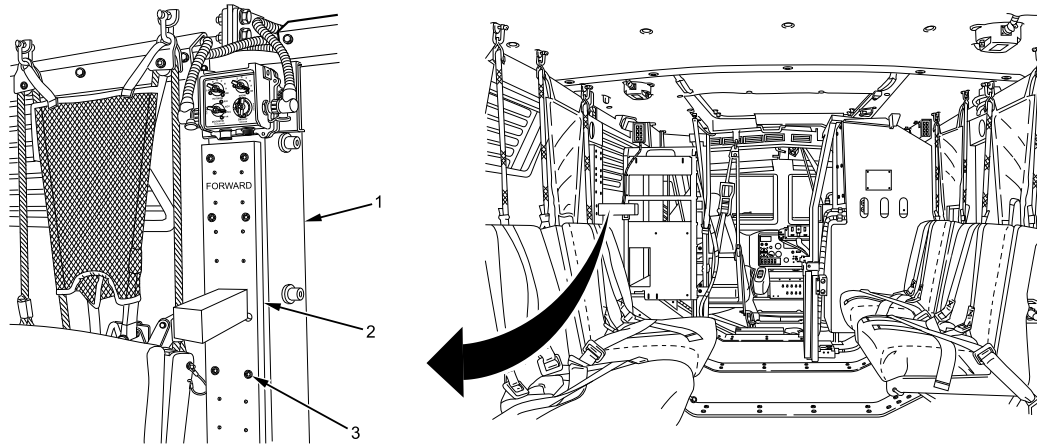

Figure 4. Arm Support.

3. Install arm support (Figure 4, Item 1) on front litter arm mount plate (Figure 4, Item 3) with two bolts (Figure 4, Item 2).

FRONT LITTER ARM MOUNT PLATE AND ARM SUPPORT REMOVAL AND INSTALLATION - (CONTINUED)

4. Install front litter arm mount plate and arm support (Figure 5, Item 2) on wall (Figure 5, Item 1) with 11 bolts (Figure 5, Item 3).



B231810657

Figure 5. Front Litter Arm Mount Plate.

END OF TASK**FOLLOW-ON MAINTENANCE**

1. Close rear door/ramp (TM 9-2355-106-10).
2. Remove wheel chocks (TM 9-2355-106-10).

END OF TASK**END OF WORK PACKAGE**

FIELD MAINTENANCE**REAR LITTER ARM MOUNT PLATE AND ARM SUPPORT REMOVAL AND INSTALLATION**

INITIAL SETUP:**Tools and Special Tools**

General Mechanic's Tool Kit (GMTK)
(WP 0795, Item 37)

WP 0786

WP 0782

Materials/Parts

Compound (WP 0794, Item 13)
Goggles, industrial (WP 0794, Item 20)
Faceshield, industrial (WP 0794, Item 16)
Gloves (WP 0794, Item 18)

Equipment Condition

Parking brake set (TM 9-2355-106-10)
Transmission set in NEUTRAL (N) (TM
9-2355-106-10)
Engine off (TM 9-2355-106-10)
MAIN POWER switch off (TM 9-2355-106-10)
Wheels chocked (TM 9-2355-106-10)
Rear door/ramp open and secured (TM
9-2355-106-10)

References

TM 9-2355-106-10
TM 9-2355-106-23P

NOTE

The rear litter arm mount plate and arm support is located on the left rear side wall.

Note orientation of rear litter arm mount plate and arm support for correct installation.

REAR LITTER ARM MOUNT PLATE AND ARM SUPPORT REMOVAL AND INSTALLATION - (CONTINUED)**REMOVAL**

1. Remove 10 bolts (Figure 1, Item 2) and rear litter arm mount plate and arm support (Figure 1, Item 3) from wall (Figure 1, Item 1).

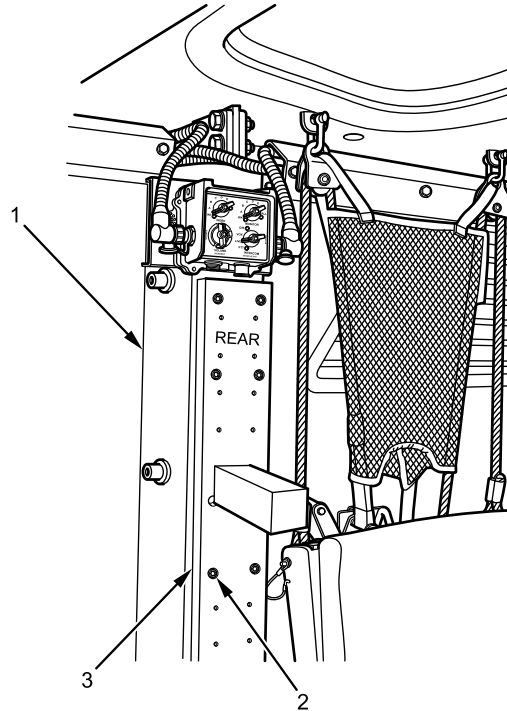

B231801967

Figure 1. Rear Litter Arm Mount Plate.

2. Remove two bolts (Figure 2, Item 2) and arm support (Figure 2, Item 1) from rear litter arm mount plate (Figure 2, Item 3).

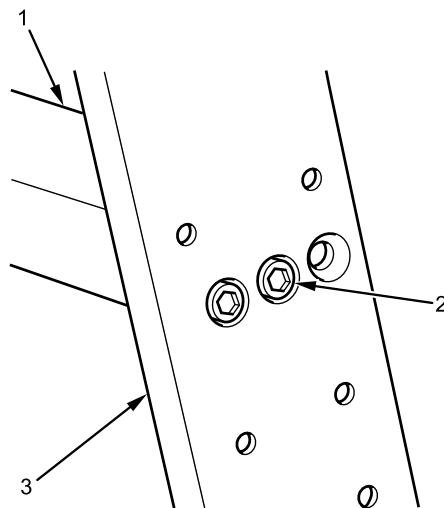

B231800707

Figure 2. Arm Support.

END OF TASK

REAR LITTER ARM MOUNT PLATE AND ARM SUPPORT REMOVAL AND INSTALLATION - (CONTINUED)**INSTALLATION**

1. Align arm support die mark (Figure 3, Item 2) with rear litter arm mount plate left die mark (Figure 3, Item 1).

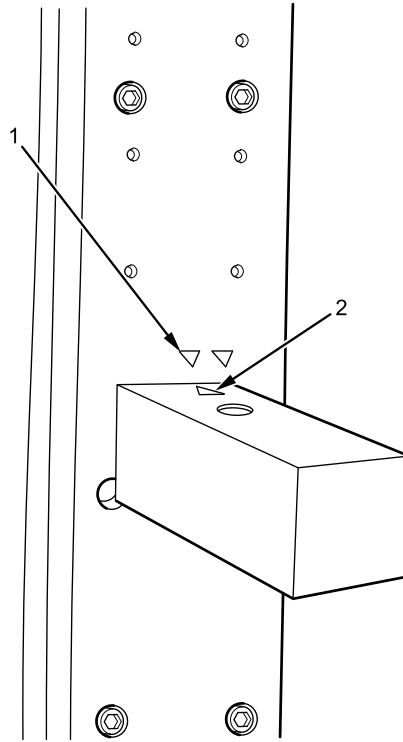

B231800708

Figure 3. Die Mark.

REAR LITTER ARM MOUNT PLATE AND ARM SUPPORT REMOVAL AND INSTALLATION - (CONTINUED)

WARNING

Corrosion preventive compound is toxic. Use only in well-ventilated area. Do not get in eyes; wear chemical safety goggles and full-face shield when using. Avoid contact with skin and wear rubber or plastic, solvent-resistant gloves. In case of contact, remove contaminated clothing and immediately wash area with soap and water. If compound contacts eyes, flush eyes with large amounts of water for at least 15 minutes and get immediate medical attention. If swallowed, do not induce vomiting; contact a physician immediately. Failure to comply may result in serious injury or death to personnel.

2. Apply corrosion preventive compound on rear litter arm mount plate and arm support bolt threads.

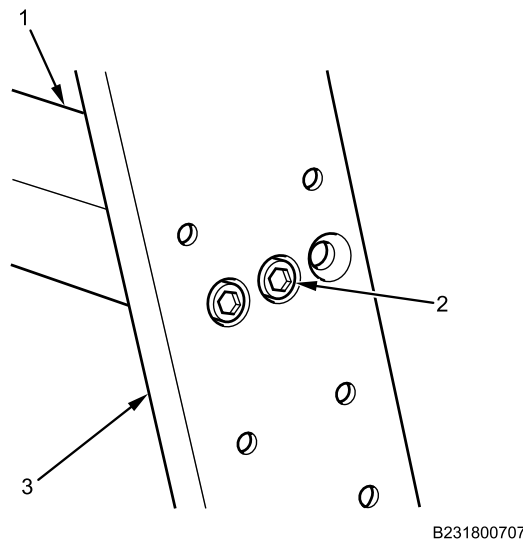
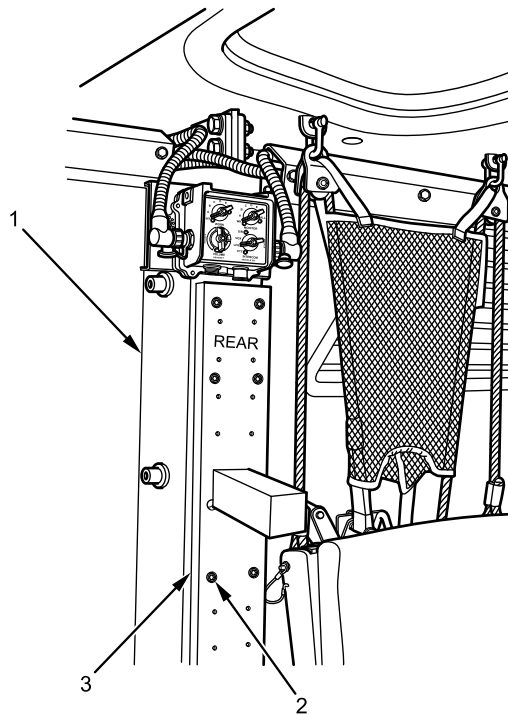

Figure 4. Arm Support.

3. Install arm support (Figure 4, Item 1) on rear litter arm mount plate (Figure 4, Item 3) with two bolts (Figure 4, Item 2). Tighten and secure.
4. Install rear litter arm mount plate and arm support (Figure 5, Item 3) on wall (Figure 5, Item 1) with 10 bolts (Figure 5, Item 2). Tighten and secure.

REAR LITTER ARM MOUNT PLATE AND ARM SUPPORT REMOVAL AND INSTALLATION - (CONTINUED)

B231801967

Figure 5. Rear Litter Arm Mount Plate.

END OF TASK**FOLLOW-ON MAINTENANCE**

1. Close and secure rear door/ramp (TM 9-2355-106-10).
2. Remove wheel chocks (TM 9-2355-106-10).

END OF TASK**END OF WORK PACKAGE**

FIELD MAINTENANCE

DOOR MOUNTED MIRROR REMOVAL AND INSTALLATION

INITIAL SETUP:

Tools and Special Tools

General Mechanic's Tool Kit (GMTK)
(WP 0795, Item 37)
Hammer, hand, soft face, dead blow, 10 oz
(WP 0795, Item 44)

TM 9-2355-106-23P

WP 0786

WP 0782

Materials/Parts

Grease (WP 0794, Item 22)

Equipment Condition

Parking brake set (TM 9-2355-106-10)

Transmission set in NEUTRAL (N) (TM
9-2355-106-10)

Engine off (TM 9-2355-106-10)

MAIN POWER switch off (TM 9-2355-106-10)

Wheels chocked (TM 9-2355-106-10)

References

TM 9-2355-106-10

NOTE

This procedure is the same for right and left side mirrors. Left side procedure shown.

REMOVAL

1. Disconnect the power mirror electrical connector (Figure 1, Item 4).

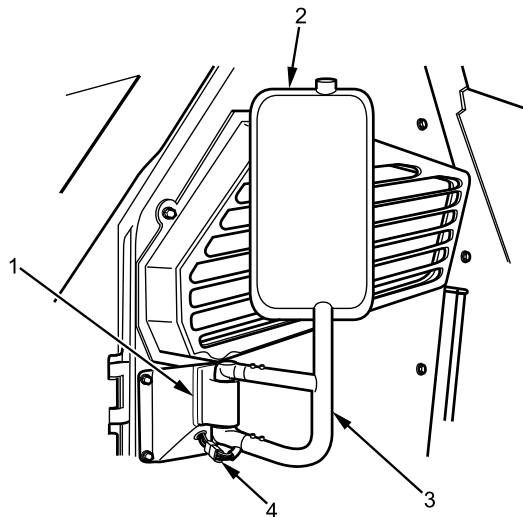

B232201616

Figure 1. Door Mounted Mirror.

2. Using a soft-face hammer, carefully tap the mirror assembly support bracket (Figure 1, Item 3) upwards to remove mirror assembly (Figure 1, Item 2) from bracket track (Figure 1, Item 1).

END OF TASK

DOOR MOUNTED MIRROR REMOVAL AND INSTALLATION - (CONTINUED)**INSTALLATION**

1. Slide mirror assembly (Figure 2, Item 2) down on bracket track (Figure 2, Item 1) until it locks in place.

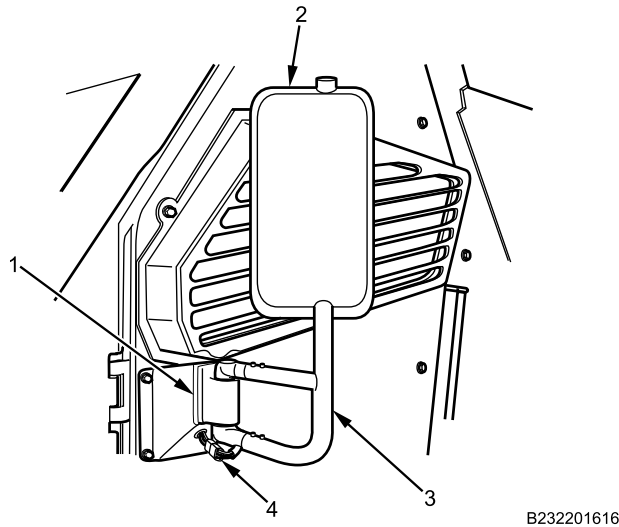

Figure 2. Door Mounted Mirror.

WARNING

Dielectric grease is harmful to skin and eyes. If grease contacts eyes, rinse thoroughly and contact physician if irritation persists. If skin is contacted, wash thoroughly with soap and water. Failure to comply may result in serious injury to personnel.

2. Apply dielectric grease in wiring harness connector.
3. Connect power mirror electrical connector (Figure 2, Item 4).
4. Manually adjust mirror to proper position using mirror assembly support bracket (Figure 2, Item 3).

END OF TASK**FOLLOW-ON MAINTENANCE**

1. Remove wheel chocks (TM 9-2355-106-10).

END OF TASK**END OF WORK PACKAGE**

FIELD MAINTENANCE

WIPER COWL PANEL REMOVAL AND INSTALLATION

INITIAL SETUP:

Tools and Special Tools

General Mechanic's Tool Kit (GMTK)
(WP 0795, Item 37)
Wrench, torque, 40-200 lb-in., 3/8-inch drive
(WP 0795, Item 142)
Socket, deep, 3/8-inch drive, 6 pt, 1-inch, chrome
(WP 0795, Item 101)

Materials/Parts

Compound (WP 0794, Item 13)
Goggles, industrial (WP 0794, Item 20)
Faceshield, industrial (WP 0794, Item 16)
Gloves (WP 0794, Item 18)

Personnel Required

Maintainer - (2)

References

TM 9-2355-106-10

TM 9-2355-106-23P

WP 0786

WP 0782

Equipment Condition

Parking brake set (TM 9-2355-106-10)
Transmission set in NEUTRAL (N) (TM
9-2355-106-10)
Engine off (TM 9-2355-106-10)
MAIN POWER switch off (TM 9-2355-106-10)
Wheels chocked (TM 9-2355-106-10)
Engine hood open and secured (TM 9-2355-106-10)
Battery cables disconnected (WP 0404)
Windshield wiper arms and blades removed
(WP 0685)

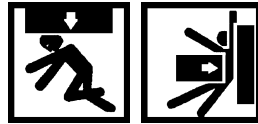
WARNING

Engine hood is extremely heavy and requires two-person lift. Ensure that there is adequate space in front of the vehicle to open hood completely without pinning or pinching personnel between hood and any other structure. Use extreme care when working under hood and make sure it is properly supported. Failure to comply may result in serious injury or death to personnel.

WIPER COWL PANEL REMOVAL AND INSTALLATION - (CONTINUED)

REMOVAL

1. Remove windshield wiper motor cover bolts and flat washers (Figure 1, Item 2 through 5) from cowl panel.

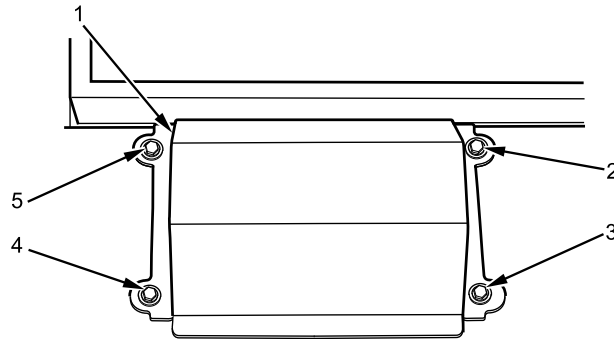

B231801443

Figure 1. Windshield Wiper Motor Cover.

2. Remove windshield wiper motor cover (Figure 1, Item 1).
3. Remove wiper arm knurled driver (Figure 2, Item 2) and weather seal cap (Figure 2, Item 3) from windshield wiper idler shaft (Figure 2, Item 1).

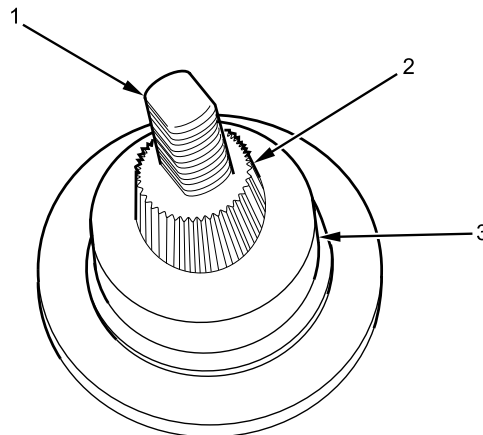

B231801444

Figure 2. Windshield Wiper Idler Shaft Driver.

4. Remove wiper arm idler shaft nut (Figure 3, Item 2) and flat washer (Figure 3, Item 3) from windshield wiper arm idler shaft (Figure 3, Item 1).

WIPER COWL PANEL REMOVAL AND INSTALLATION - (CONTINUED)

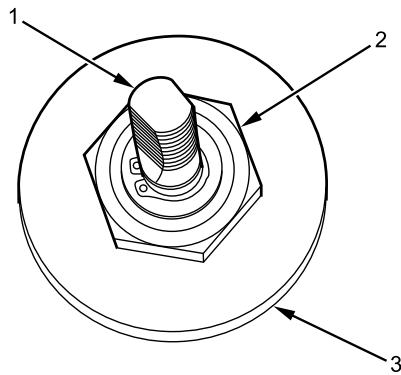

B231801445

Figure 3. Windshield Wiper Idler Shaft Nut.

5. Remove cowl panel bolts and flat washers (Figure 4, Item 1 through 6) from cowl panel.

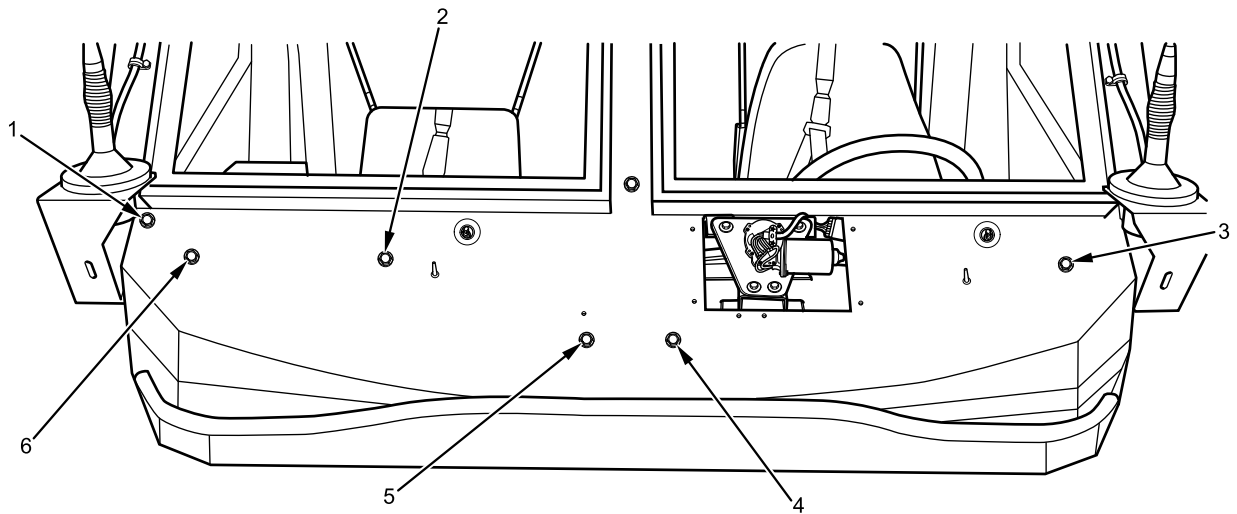

B231801448

Figure 4. Cowl Panel.

6. Place cowl panel (Figure 5, Item 1) upside down across engine to access windshield washer hoses.

WIPER COWL PANEL REMOVAL AND INSTALLATION - (CONTINUED)

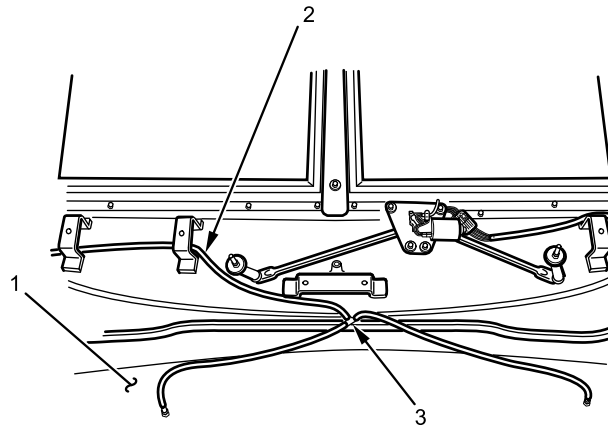

B232201381

Figure 5. Windshield Washer Pump Hose.

7. Remove windshield washer pump hose (Figure 5, Item 2) from windshield washer hose T-fitting (Figure 5, Item 3).
8. Remove cowl panel (Figure 5, Item 1) from vehicle and place on workbench.
9. Remove windshield washer hose T-fitting (Figure 6, Item 5) from windshield washer hoses (Figure 6, Item 4 and 6).

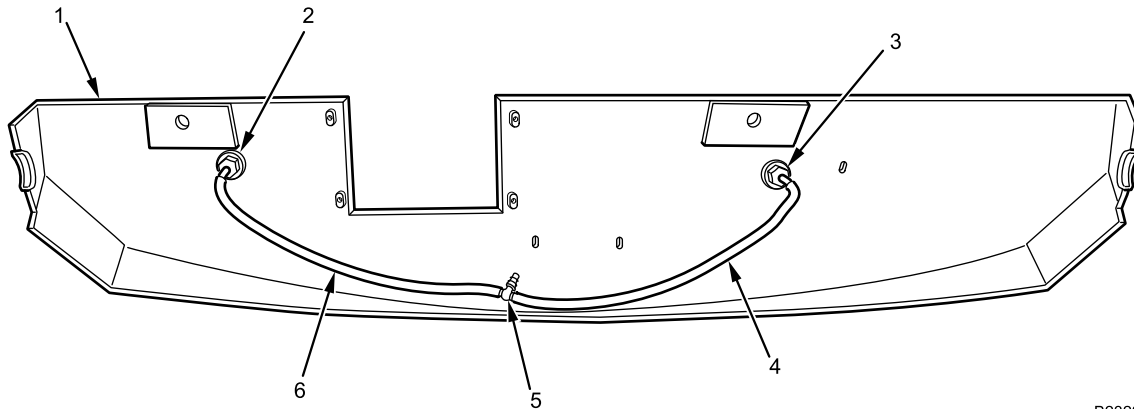

B232201387

Figure 6. Underside of Cowl Panel.

10. Remove windshield washer hoses (Figure 6, Item 4 and 6) from wet arm adapters (Figure 6, Item 2 and 3) on cowl panel (Figure 6, Item 1).
11. Remove nut (Figure 7, Item 1) from wet arm adapters (Figure 7, Item 2) on cowl panel.

WIPER COWL PANEL REMOVAL AND INSTALLATION - (CONTINUED)

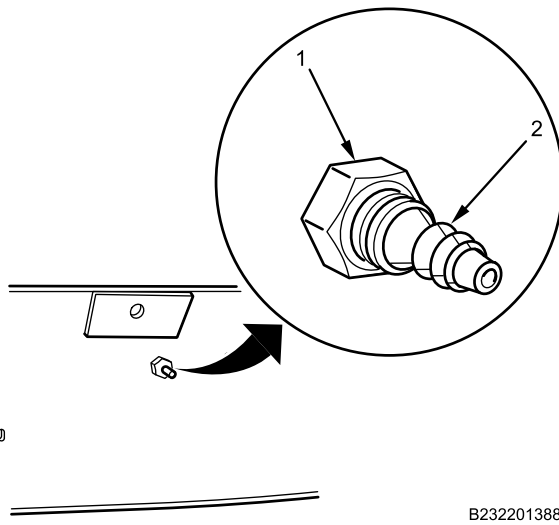

B232201388

Figure 7. Windshield Washer Wet Arm Adapter Nut.

12. Remove windshield washer wet arm adapters (Figure 8, Item 1) and washer seals (Figure 8, Item 2) from cowl panel.

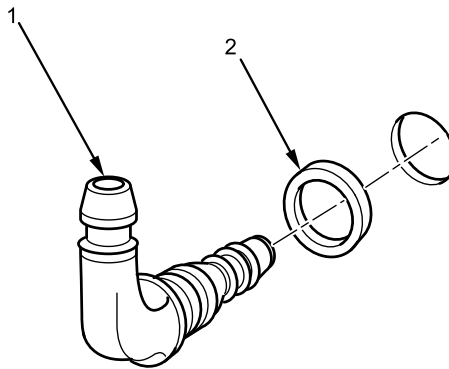

B232201390

Figure 8. Windshield Washer Wet Arm Adapter and Sealing Washer.

END OF TASK

WIPER COWL PANEL REMOVAL AND INSTALLATION - (CONTINUED)**INSTALLATION****WARNING**

Corrosion preventive compound is toxic. Use only in well-ventilated area. Do not get in eyes; wear chemical safety goggles and full-face shield when using. Avoid contact with skin and wear rubber or plastic, solvent-resistant gloves. In case of contact, remove contaminated clothing and immediately wash area with soap and water. If compound contacts eyes, flush eyes with large amounts of water for at least 15 minutes and get immediate medical attention. If swallowed, do not induce vomiting; contact a physician immediately. Failure to comply may result in serious injury or death to personnel.

1. Install windshield washer wet arm adapters (Figure 9, Item 1) and washer seals (Figure 9, Item 2) on cowl panel.

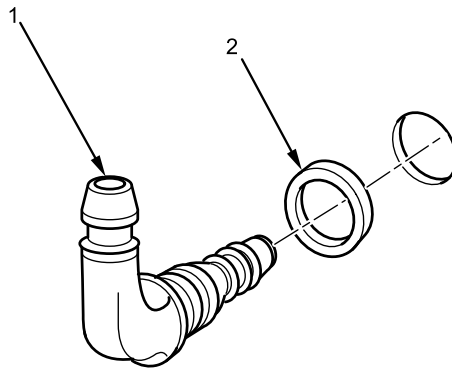

B232201390

Figure 9. Windshield Washer Wet Arm Adapter and Sealing Washer.

2. Loosely install nuts (Figure 10, Item 1) on windshield washer wet arm adapters (Figure 10, Item 2) on cowl panel.

WIPER COWL PANEL REMOVAL AND INSTALLATION - (CONTINUED)

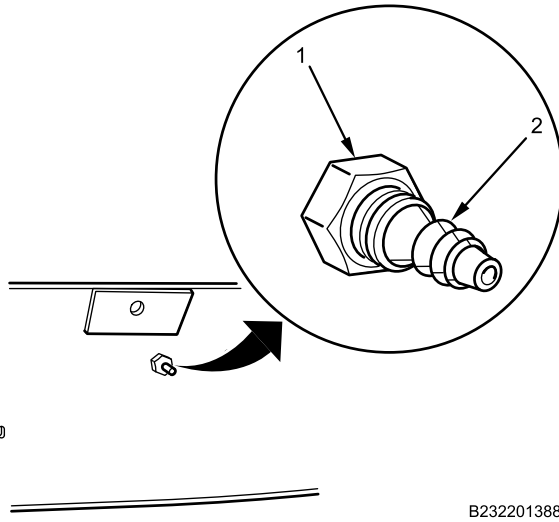

B232201388

Figure 10. Windshield Washer Wet Arm Adapter Nut.

CAUTION

Do not overtighten nuts. Overtightening can damage plastic parts.

3. Align exterior side of windshield washer wet arm adapter (Figure 11, Item 2 and 3) towards top edge (Figure 11, Item 1) of cowl panel and tighten nuts (Figure 11, Item 1) securely.

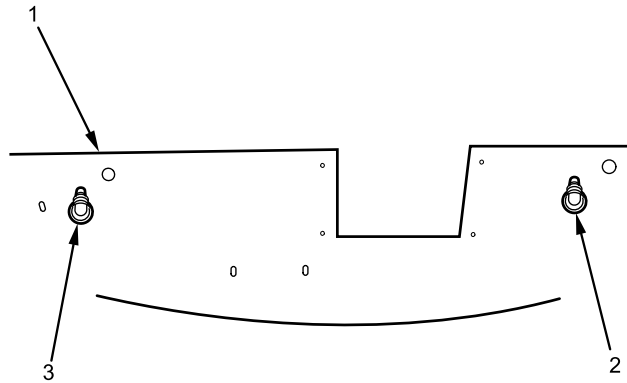

B232201389

Figure 11. Windshield Washer Wet Arm Adapter Alignment.

4. Install windshield washer hoses (Figure 12, Item 5 and 7) on wet arm adapters (Figure 12, Item 2 and 3) on cowl panel (Figure 12, Item 1).

WIPER COWL PANEL REMOVAL AND INSTALLATION - (CONTINUED)

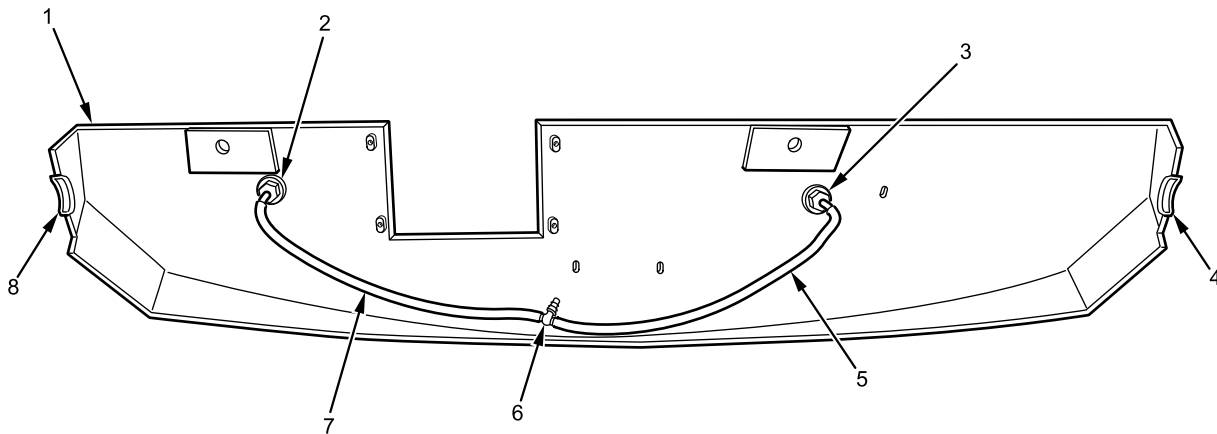

B232201392

Figure 12. Underside of Cowl Panel.

5. Install windshield washer hose T-fitting (Figure 12, Item 6) on windshield washer hoses (Figure 12, Item 5 and 7).
6. Ensure harness guards (Figure 12, Item 4 and 8) are in place.
7. Install cowl panel (Figure 13, Item 1) on vehicle and place upside down across engine.

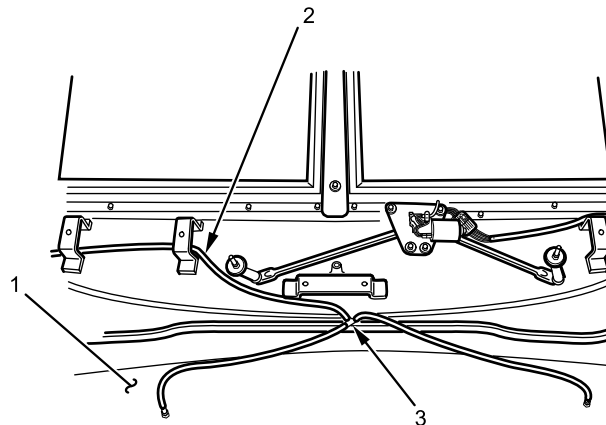

B232201381

Figure 13. Windshield Washer Pump Hose.

8. Install windshield washer pump hose (Figure 13, Item 2) on windshield washer hose T-fitting (Figure 13, Item 3).
9. Place wiper idler shafts (Figure 14, Item 2) and wiper idler shaft arms (Figure 14, Item 1) aligned vertically, and linkage pivots (Figure 14, Item 3) and connector link assemblies (Figure 14, Item 4) aligned at base of cowl.

WIPER COWL PANEL REMOVAL AND INSTALLATION - (CONTINUED)

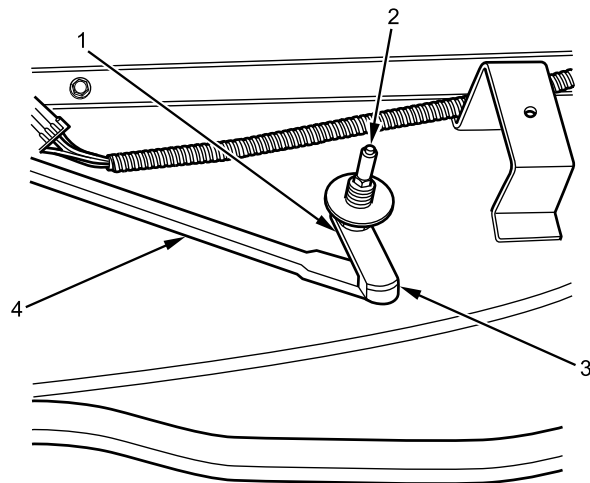

B232201397

Figure 14. Windshield Wiper Linkage and Idler Shaft Alignment.

10. Install cowl panel (Figure 15, Item 1) into position, with idler shafts (Figure 15, Item 2) aligned to cowl panel holes (Figure 15, Item 3).

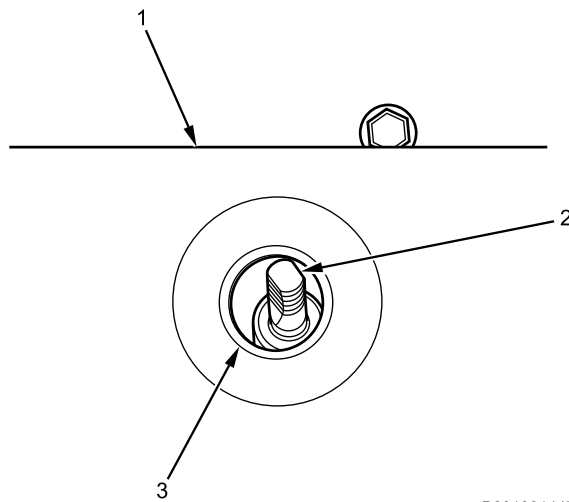

B231801447

Figure 15. Windshield Wiper Idler Shaft.

11. Apply corrosion preventive compound to wiper arm idler shaft nut and flat washer before assembly.
12. Install flat washer (Figure 16, Item 3) and nut (Figure 16, Item 2) on windshield wiper arm idler shaft (Figure 16, Item 1). Finger-tighten nut.

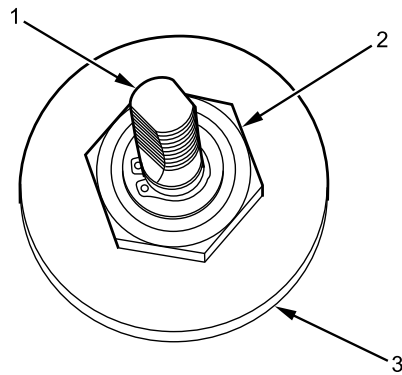
WIPER COWL PANEL REMOVAL AND INSTALLATION - (CONTINUED)

B231801445

Figure 16. Windshield Wiper Idler Shaft Nut.

13. Ensure windshield wiper washer hose assembly (Figure 17, Item 2) is aligned to cutout in cowl panel (Figure 17, Item 1).

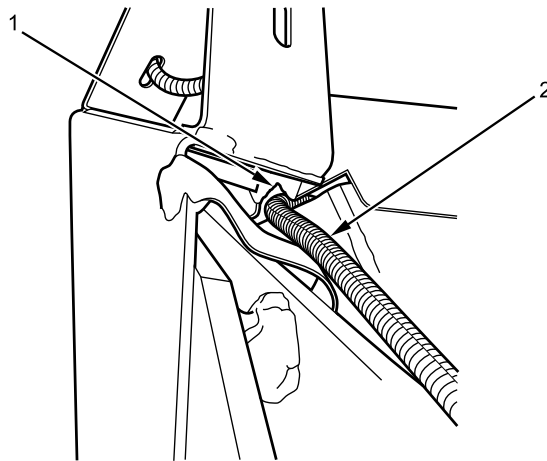

B231801449

Figure 17. Windshield Wiper Washer Hose.

14. Ensure windshield wiper wiring harness assembly (Figure 18, Item 2) is aligned to cutout in cowl panel (Figure 18, Item 1).

WIPER COWL PANEL REMOVAL AND INSTALLATION - (CONTINUED)

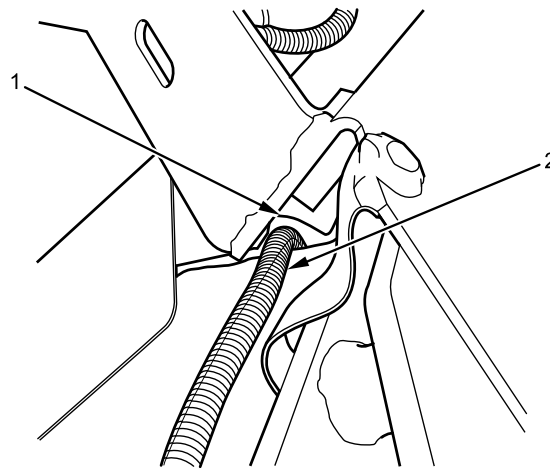

B231801450

Figure 18. Windshield Wiper Motor Wiring Harness.

15. Apply corrosion preventive compound to cowl panel bolts (Figure 19, Item 1 through 6).

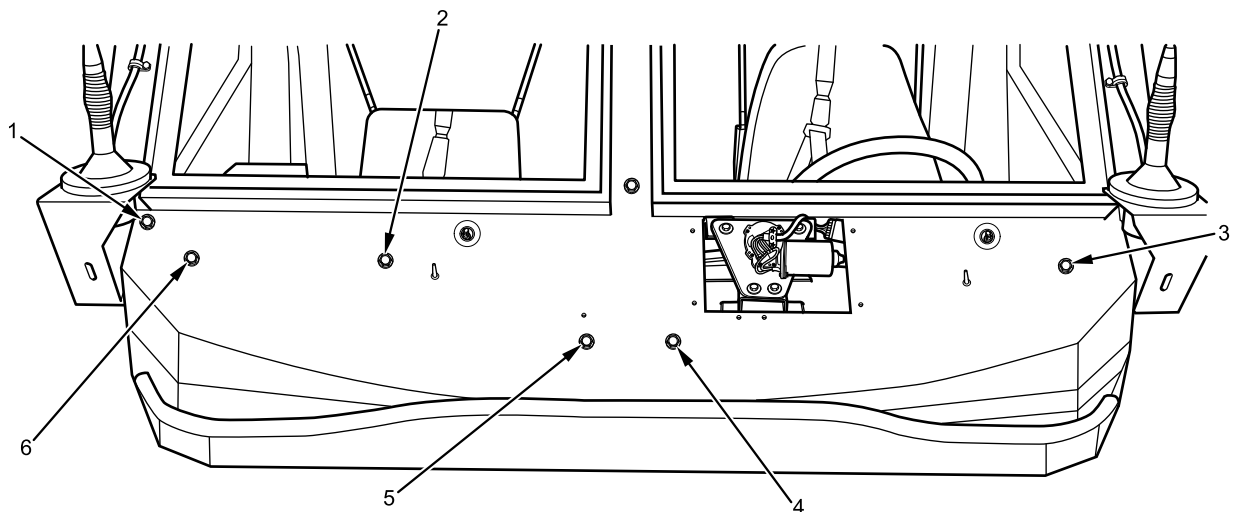

B231801448

Figure 19. Cowl Panel.

16. Install cowl panel bolts and flat washers (Figure 19, Item 1 through 6) on cowl panel. Position cowl panel as high as possible and torque bolts to 155-190 lb-in. (18-22 N•m).
17. Torque windshield wiper arm idler shaft nut (Figure 19, Item 2) to 155-190 lb-in. (18-22 N•m).
18. Install weather seal cap (Figure 20, Item 3) and wiper arm knurled driver (Figure 20, Item 2) on windshield wiper idler shaft (Figure 20, Item 1).

WIPER COWL PANEL REMOVAL AND INSTALLATION - (CONTINUED)

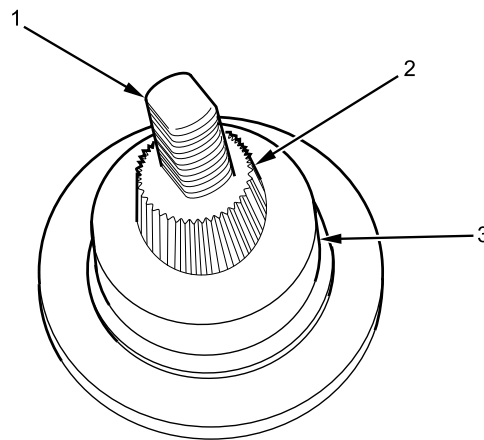

B231801444

Figure 20. Windshield Wiper Idler Shaft Driver.

19. Position windshield wiper motor cover (Figure 21, Item 1) on cowl panel.

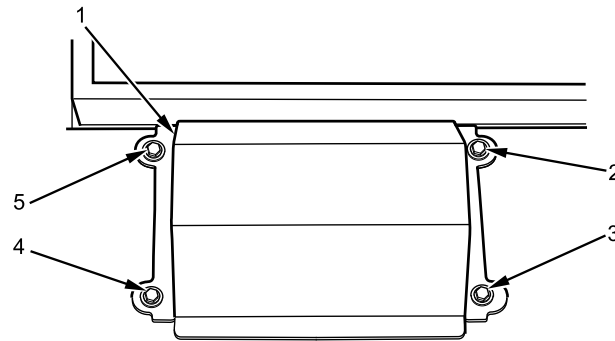

B231801443

Figure 21. Windshield Wiper Motor Cover.

20. Apply corrosion preventive compound to windshield wiper motor cover bolts (Figure 21, Item 2 through 5).
 21. Install windshield wiper motor cover bolts and flat washers (Figure 21, Item 2 through 4) and torque to 115-140 lb-in. (13-16 N•m).

END OF TASK**FOLLOW-ON MAINTENANCE**

1. Install windshield wiper arms and blades (WP 0685).
2. Connect battery cables (WP 0404).
3. Close and secure engine hood (TM 9-2355-106-10).
4. Turn MAIN POWER switch on (TM 9-2355-106-10).
5. Verify windshield washer and windshield wiper arm and blade operation (TM 9-2355-106-10).
6. Turn MAIN POWER switch off (TM 9-2355-106-10).
7. Remove wheel chocks (TM 9-2355-106-10).

END OF TASK**END OF WORK PACKAGE**

FIELD MAINTENANCE
WINDSHIELD WIPER MOTOR, TRANSMISSION, BRACKET, AND LINKAGE ASSEMBLY REMOVAL AND INSTALLATION

INITIAL SETUP:**Tools and Special Tools**

General Mechanic's Tool Kit (GMTK)
(WP 0795, Item 37)
Wrench, torque, 40-200 lb-in. 3/8-inch drive
(WP 0795, Item 142)

TM 9-2355-106-23P

WP 0782

Equipment Condition

Parking brake set (TM 9-2355-106-10)
Transmission set in NEUTRAL (N) (TM
9-2355-106-10)
Engine off (TM 9-2355-106-10)
MAIN POWER switch off (TM 9-2355-106-10)
Wheels chocked (TM 9-2355-106-10)
Engine hood open and secured (TM 9-2355-106-10)
Wiper cowl panel removed (WP 0683)

Materials/Parts

Compound (WP 0794, Item 13)
Grease (WP 0794, Item 22)
Gloves (WP 0794, Item 18)
Cable lock strap (WP 0796, Item 124)

References

TM 9-2355-106-10

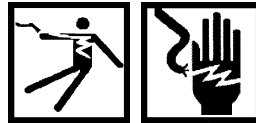
WARNING

Use extreme caution when testing or working on or around electrical circuits. Always assume that electrical circuits are live. Electrical shock can occur upon contact with voltage high enough to cause current flow through muscles or nerves. On Direct Current (DC) systems, generally 1 milliamp of current can be felt, 5 milliamps can cause severe pain, 15 milliamps can cause loss of muscle control, and 70 milliamps can be fatal. Wear protective clothing; ensure skin, clothing, and surrounding areas are dry; do not wear jewelry; and touch only the insulated, nonmetallic parts of electrical components and testing equipment. To prevent electrical arcing, avoid shorting electrical test probes and jumper wires. Electrical arcing can cause bright flashes of light, capable of causing temporary blindness. If electrical injury occurs, immediately shut off power supply and seek medical assistance. Failure to comply may result in serious injury or death to personnel.

WINDSHIELD WIPER MOTOR, TRANSMISSION, BRACKET, AND LINKAGE ASSEMBLY REMOVAL AND INSTALLATION - (CONTINUED)

REMOVAL

1. Remove windshield wiper motor harness cable lock strap (Figure 1, Item 2) from windshield wiper motor harness (Figure 1, Item 1) on windshield wiper motor cowl bracket (Figure 1, Item 3). Discard cable lock strap.

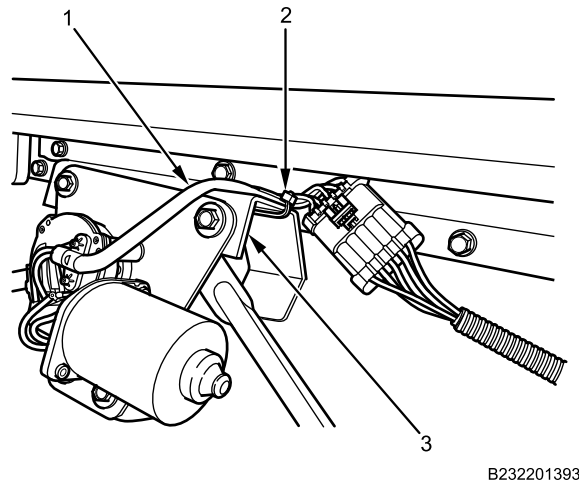

Figure 1. Windshield Wiper Motor Harness Cable Lock Strap.

2. Disengage windshield wiper motor harness lock (Figure 2, Item 2) and disconnect windshield wiper motor harness (Figure 2, Item 1) from vehicle harness (Figure 2, Item 3).

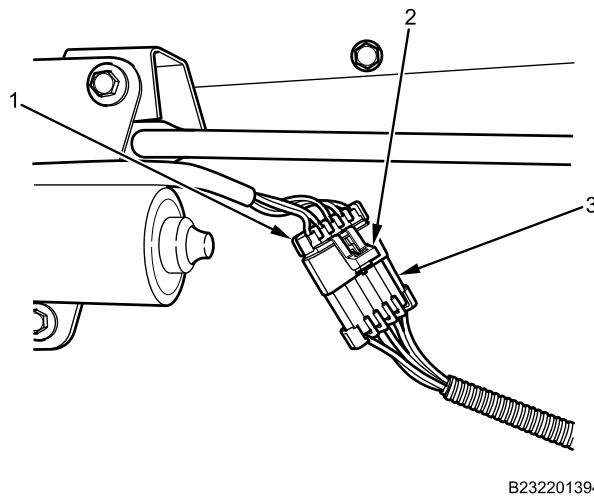
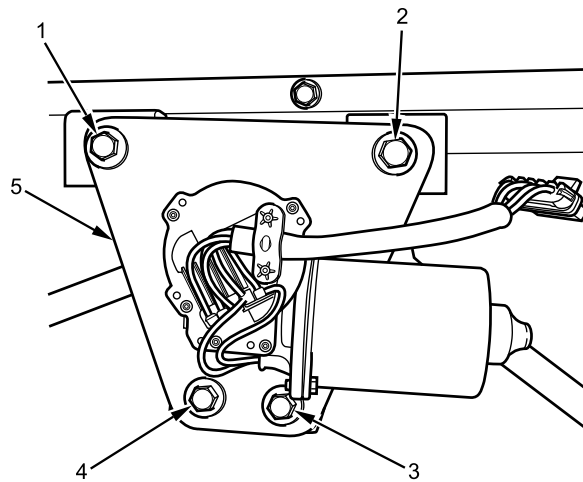

Figure 2. Windshield Wiper Motor Harness.

WINDSHIELD WIPER MOTOR, TRANSMISSION, BRACKET, AND LINKAGE ASSEMBLY REMOVAL AND INSTALLATION - (CONTINUED)

3. Remove windshield wiper motor assembly bolts (Figure 3, Item 1 through 4) from windshield wiper motor bracket (Figure 3, Item 5).



B232201395

Figure 3. Windshield Wiper Motor Assembly Bolts.

4. Remove windshield wiper motor assembly with transmission and linkage (Figure 4, Item 1) from cowl bracket (Figure 4, Item 2).

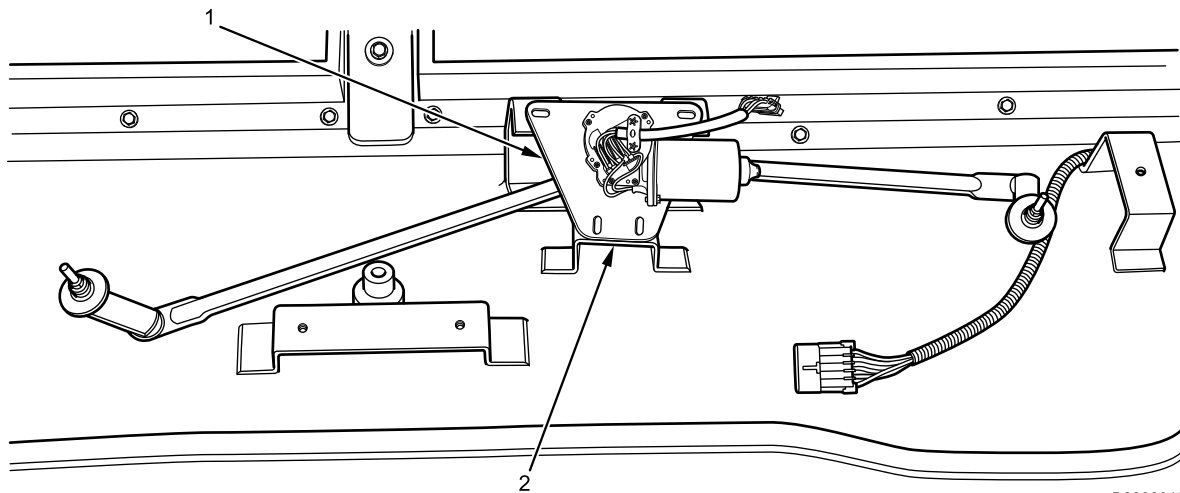

B232201396

Figure 4. Windshield Wiper Motor Assembly.

END OF TASK

WINDSHIELD WIPER MOTOR, TRANSMISSION, BRACKET, AND LINKAGE ASSEMBLY REMOVAL AND INSTALLATION - (CONTINUED)

INSTALLATION

WARNING



Dielectric grease is harmful to skin and eyes. If grease contacts eyes, rinse thoroughly and contact physician if irritation persists. If skin is contacted, wash thoroughly with soap and water. Failure to comply may result in serious injury to personnel.

Corrosion preventive compound is toxic. Use only in well-ventilated area. Use approved respirator with dual organic vapor/mist and particulate cartridge. Do not get in eyes; wear chemical safety goggles and full-face shield when using. Avoid contact with skin and wear rubber or plastic, solvent-resistant gloves. In case of contact, remove contaminated clothing and immediately wash area with soap and water. If compound contacts eyes, flush eyes with large amounts of water for at least 15 minutes and get immediate medical attention. If swallowed, do not induce vomiting; contact a physician immediately. Failure to comply may result in serious injury or death to personnel.

NOTE

Apply dielectric grease to all electrical connections.

Apply corrosion preventive compound on all nuts and bolts.

1. Install windshield wiper motor assembly with transmission and linkage (Figure 5, Item 1) on cowl bracket (Figure 5, Item 2).

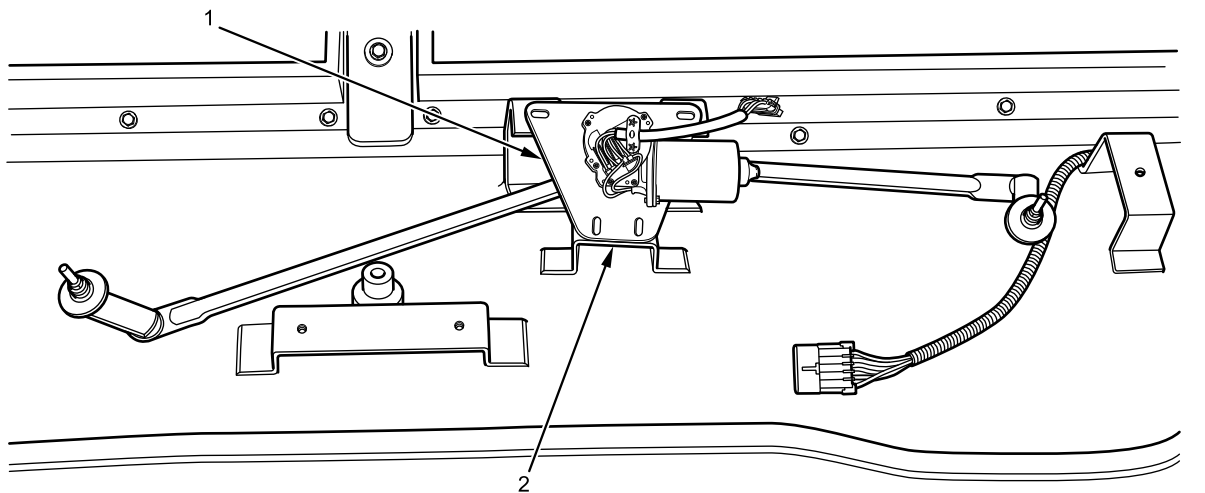

B232201396

Figure 5. Windshield Wiper Motor Assembly.

WINDSHIELD WIPER MOTOR, TRANSMISSION, BRACKET, AND LINKAGE ASSEMBLY REMOVAL AND INSTALLATION - (CONTINUED)

2. Install windshield wiper motor assembly bolts (Figure 6, Item 1 through 4) on windshield wiper motor bracket (Figure 6, Item 5) and torque to 155-190 lb-in. (18-22 N•m).

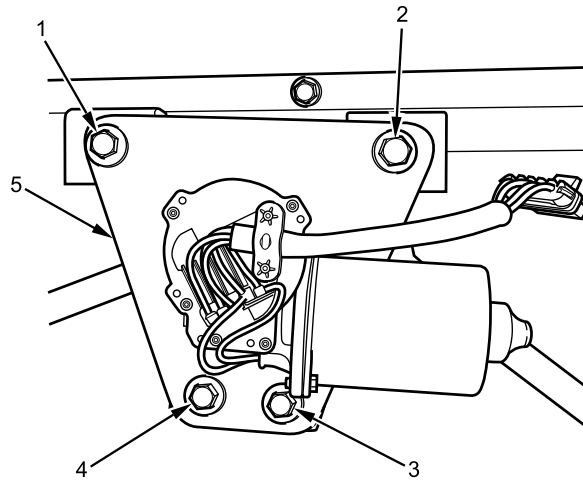

B232201395

Figure 6. Windshield Wiper Motor Assembly Bolts.

3. Apply dielectric grease in electrical connector (Figure 7, Item 3).

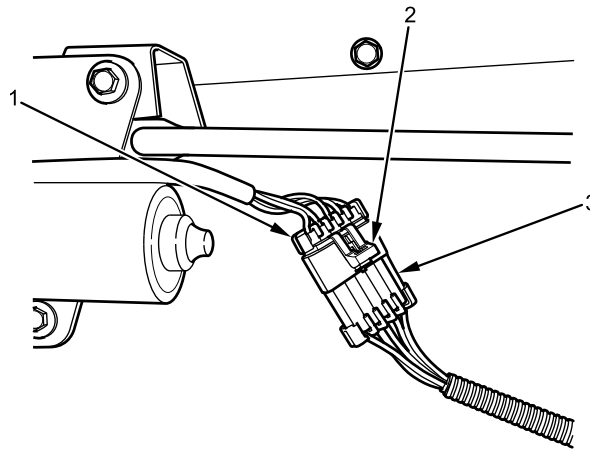

B232201394

Figure 7. Windshield Wiper Motor Harness.

4. Connect windshield wiper motor harness (Figure 7, Item 1) to vehicle harness (Figure 7, Item 3), and ensure windshield wiper motor harness connector (Figure 7, Item 2) locks.

WINDSHIELD WIPER MOTOR, TRANSMISSION, BRACKET, AND LINKAGE ASSEMBLY REMOVAL AND INSTALLATION - (CONTINUED)

Figure 8. Windshield Wiper Motor Harness Cable Lock Strap.

5. Install new windshield wiper motor harness cable lock strap (Figure 8, Item 2) on windshield wiper motor harness (Figure 8, Item 1) on windshield wiper motor cowl bracket (Figure 8, Item 3).

END OF TASK**FOLLOW-ON MAINTENANCE**

1. Install wiper cowl panel (WP 0683).
2. Turn MAIN POWER switch on (TM 9-2355-106-10).
3. Verify windshield washer and windshield wiper arm and blade assemblies operation (TM 9-2355-106-10).
4. Turn MAIN POWER switch off (TM 9-2355-106-10).
5. Close engine hood (TM 9-2355-106-10).
6. Remove wheel chocks (TM 9-2355-106-10).

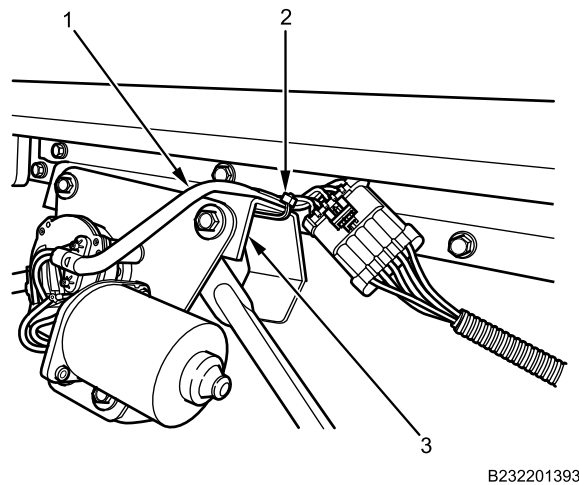
END OF TASK**END OF WORK PACKAGE**

FIELD MAINTENANCE

WINDSHIELD WIPER ARM AND BLADE ASSEMBLY REMOVAL AND INSTALLATION

INITIAL SETUP:

Tools and Special Tools

General Mechanic's Tool Kit (GMTK)
(WP 0795, Item 37)
Wrench, torque, 40-200 lb-in. 3/8-inch drive
(WP 0795, Item 142)

Materials/Parts

Lockwasher - (2) (WP 0796, Item 3)

References

TM 9-2355-106-10

TM 9-2355-106-23P

WP 0782

Equipment Condition

Parking brake set (TM 9-2355-106-10)
Transmission set in NEUTRAL (N) (TM
9-2355-106-10)
Engine off (TM 9-2355-106-10)
MAIN POWER switch off (TM 9-2355-106-10)
Wheels chocked (TM 9-2355-106-10)

REMOVAL

1. Remove windshield wiper arm nut (Figure 1, Item 2) from windshield wiper arm and blade assembly (Figure 1, Item 1).

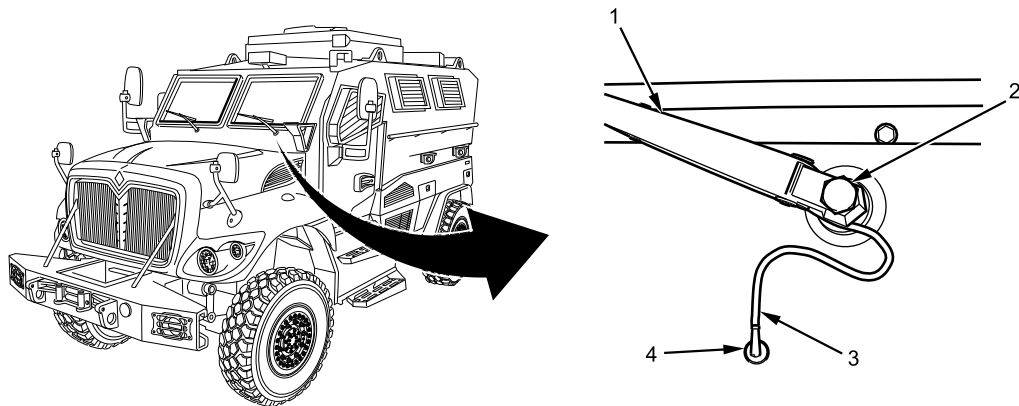

B232210627

Figure 1. Windshield Wiper Arm Nut and Washer Hose.

2. Remove windshield washer hose (Figure 1, Item 3) from wet arm adapter (Figure 1, Item 4) in cowl panel.

WINDSHIELD WIPER ARM AND BLADE ASSEMBLY REMOVAL AND INSTALLATION - (CONTINUED)

3. Remove internal lockwasher (Figure 2, Item 2) from windshield wiper arm and blade assembly (Figure 2, Item 1). Discard lockwasher (Figure 2, Item 2).

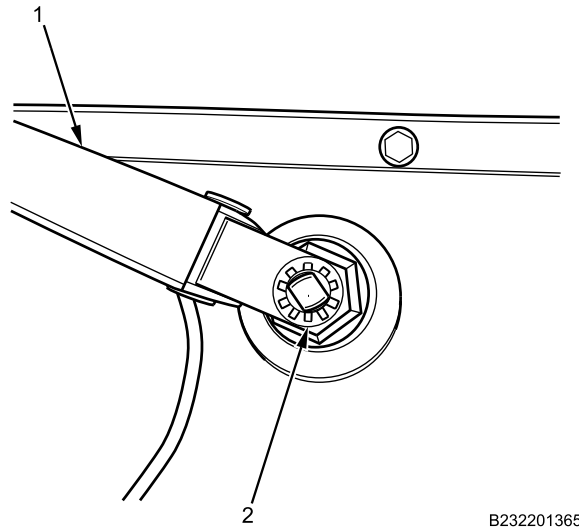

B232201365

Figure 2. Windshield Wiper Arm Lockwasher.

4. Remove windshield wiper arm and blade assembly (Figure 3, Item 1) from windshield wiper idler shaft by prying up with screwdrivers (Figure 3, Item 2 and 3), using equal force on each side of windshield wiper arm base.

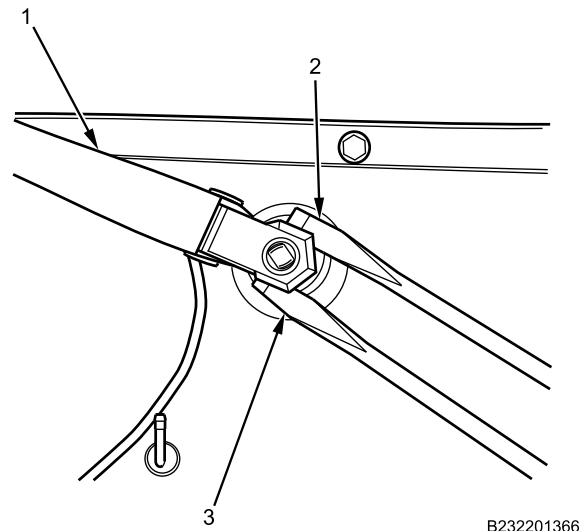

B232201366

Figure 3. Windshield Wiper Arm and Blade Assembly.

WINDSHIELD WIPER ARM AND BLADE ASSEMBLY REMOVAL AND INSTALLATION - (CONTINUED)

5. Ensure knurled driver (Figure 4, Item 1) is removed from windshield wiper arm and blade assembly and is in place on idler shaft (Figure 4, Item 2).

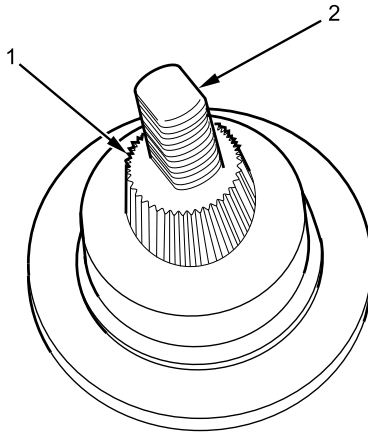

B232201367

Figure 4. Knurled Driver on Idler Shaft.

END OF TASK**INSTALLATION**

1. Install windshield wiper arm and blade assembly (Figure 5, Item 3) on idler shaft (Figure 5, Item 2). Ensure windshield wiper blade (Figure 5, Item 1) is parallel with base of windshield (Figure 5, Item 4).

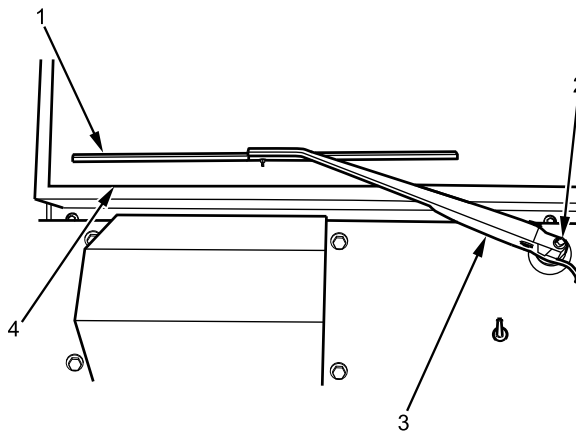

B232201368

Figure 5. Windshield Wiper Arm and Blade Assembly Installation and Alignment.

WINDSHIELD WIPER ARM AND BLADE ASSEMBLY REMOVAL AND INSTALLATION - (CONTINUED)

2. Install new lockwasher (Figure 6, Item 2) on windshield wiper arm and blade assembly (Figure 6, Item 1).

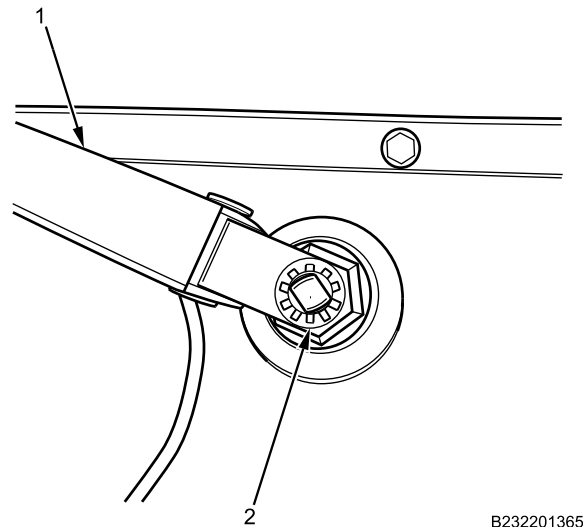

Figure 6. Windshield Wiper Arm Lockwasher.

3. Install windshield wiper arm nut (Figure 7, Item 2) on windshield wiper arm and blade assembly (Figure 7, Item 1).

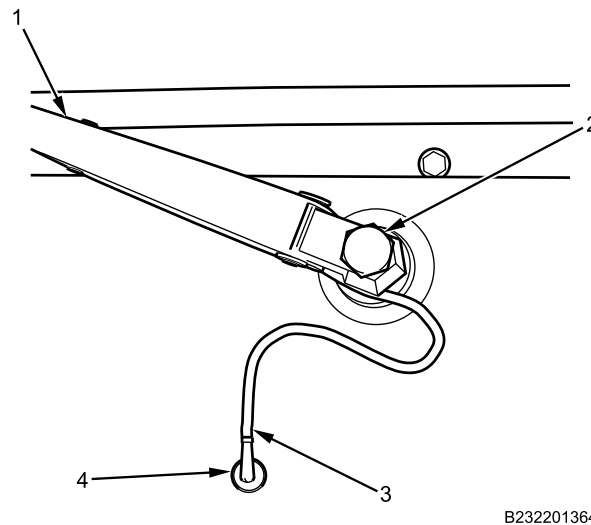

Figure 7. Windshield Wiper Arm Nut and Washer Hose.

4. Torque windshield wiper arm and blade assembly nut (Figure 7, Item 2) to 90-110 lb-in. (10-12 N•m).
5. Install windshield washer hose (Figure 7, Item 3) on wet arm adapter (Figure 7, Item 4) in cowl panel.

END OF TASK

WINDSHIELD WIPER ARM AND BLADE ASSEMBLY REMOVAL AND INSTALLATION - (CONTINUED)**FOLLOW-ON MAINTENANCE**

1. Turn MAIN POWER switch on (TM 9-2355-106-10).
2. Verify windshield washer and windshield wiper arm and blade assemblies operation (TM 9-2355-106-10).
3. Turn MAIN POWER switch off (TM 9-2355-106-10).
4. Remove wheel chocks (TM 9-2355-106-10).

END OF TASK**END OF WORK PACKAGE**

FIELD MAINTENANCE
WINDSHIELD WASHER RESERVOIR AND PUMP MOTOR ASSEMBLY REMOVAL AND INSTALLATION

INITIAL SETUP:**Tools and Special Tools**

General Mechanic's Tool Kit (GMTK)
(WP 0795, Item 37)
Drain pan (WP 0795, Item 75)
Dial torque wrench, 3/8-inch drive (300 lb-in.)
(WP 0795, Item 147)

Materials/Parts

Compound (WP 0794, Item 13)
Grease (WP 0794, Item 22)
Gloves (WP 0794, Item 18)

References

TM 9-2355-106-10

TM 9-2355-106-23P

WP 0782

Equipment Condition

Parking brake set (TM 9-2355-106-10)
Transmission set in NEUTRAL (N) (TM
9-2355-106-10)
Engine off (TM 9-2355-106-10)
MAIN POWER switch off (TM 9-2355-106-10)
Wheels chocked (TM 9-2355-106-10)
Engine hood open and secure (TM 9-2355-106-10)

WARNING

Use extreme caution when testing or working on or around electrical circuits. Always assume that electrical circuits are live. Electrical shock can occur upon contact with voltage high enough to cause current flow through muscles or nerves. On Direct Current (DC) systems, generally 1 milliamp of current can be felt, 5 milliamps can cause severe pain, 15 milliamps can cause loss of muscle control, and 70 milliamps can be fatal. Wear protective clothing; ensure skin, clothing, and surrounding areas are dry; do not wear jewelry; and touch only the insulated, nonmetallic parts of electrical components and testing equipment. To prevent electrical arcing, avoid shorting electrical test probes and jumper wires. Electrical arcing can cause bright flashes of light, capable of causing temporary blindness. If electrical injury occurs, immediately shut off power supply and seek medical assistance. Failure to comply may result in serious injury or death to personnel.

Engine hood is extremely heavy and requires two-person lift. Ensure that there is adequate space in front of the vehicle to open hood completely without pinning or pinching personnel between hood and any other structure. Use extreme care when working under hood and make sure it is properly supported. Failure to comply may result in serious injury or death to personnel.

WINDSHIELD WASHER RESERVOIR AND PUMP MOTOR ASSEMBLY REMOVAL AND INSTALLATION - (CONTINUED)

REMOVAL

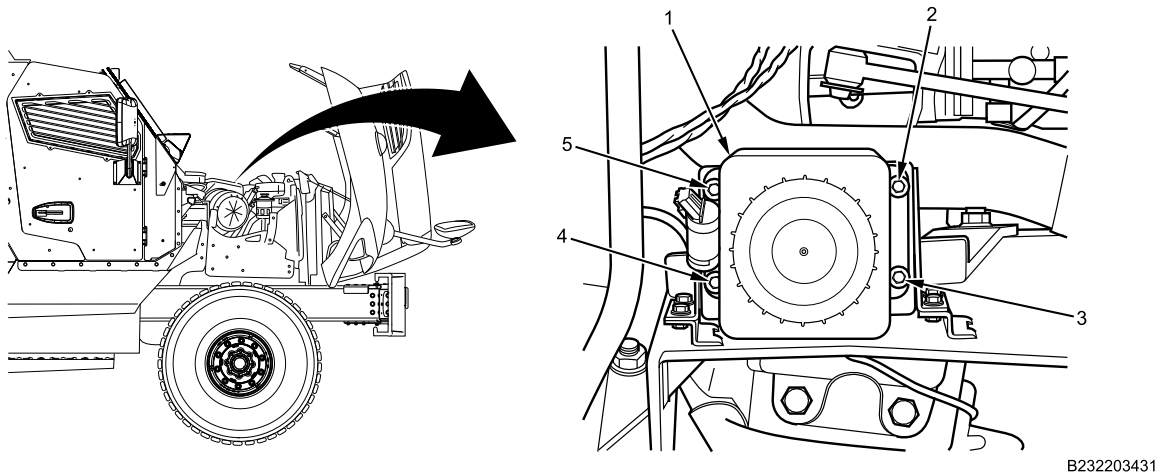

Figure 1. Windshield Washer Fluid Reservoir.

1. Remove four windshield washer reservoir and pump assembly bolts (Figure 1, Item 2 through 5) from windshield washer reservoir and pump assembly (Figure 1, Item 1).

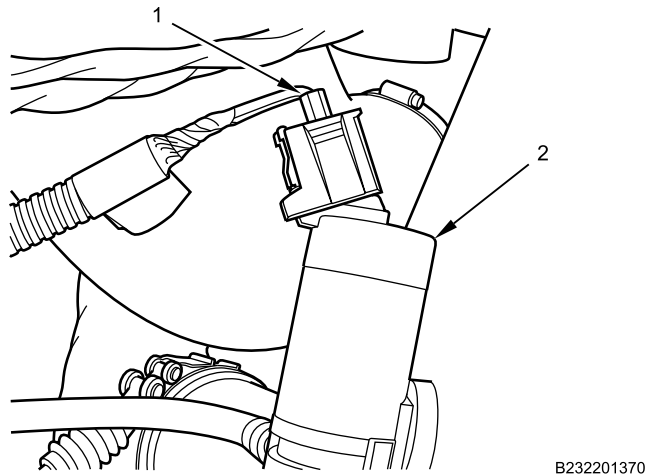

Figure 2. Windshield Washer Pump Harness Connector.

2. Remove windshield washer pump wiring harness connector (Figure 2, Item 1) from windshield washer pump (Figure 2, Item 2).

**WINDSHIELD WASHER RESERVOIR AND PUMP MOTOR ASSEMBLY REMOVAL AND INSTALLATION -
(CONTINUED)**

Figure 3. Windshield Washer Pump Hose.

3. Remove windshield washer hose (Figure 3, Item 3) from windshield washer pump (Figure 3, Item 1) and drain windshield washer fluid into clean drain pan.
4. Remove windshield washer reservoir and pump assembly from windshield washer and pump assembly bracket (Figure 3, Item 2).
5. Remove drain pan.

END OF TASK

WINDSHIELD WASHER RESERVOIR AND PUMP MOTOR ASSEMBLY REMOVAL AND INSTALLATION - (CONTINUED)

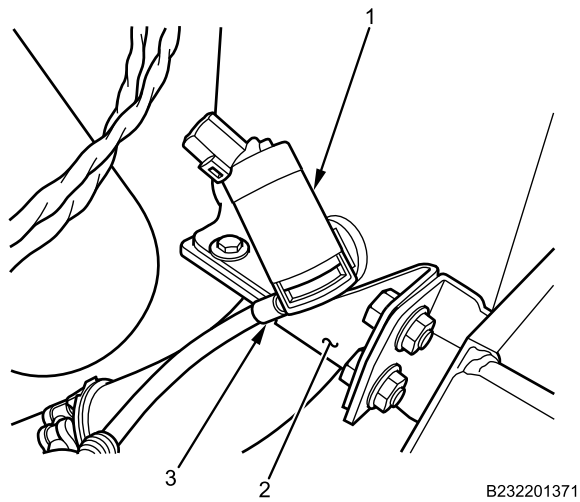
INSTALLATION

WARNING



Dielectric grease is harmful to skin and eyes. If grease contacts eyes, rinse thoroughly and contact physician if irritation persists. If skin is contacted, wash thoroughly with soap and water. Failure to comply may result in serious injury to personnel.

Corrosion preventive compound is toxic. Use only in well-ventilated area. Use approved respirator with dual organic vapor/mist and particulate cartridge. Do not get in eyes; wear chemical safety goggles and full-face shield when using. Avoid contact with skin and wear rubber or plastic, solvent-resistant gloves. In case of contact, remove contaminated clothing and immediately wash area with soap and water. If compound contacts eyes, flush eyes with large amounts of water for at least 15 minutes and get immediate medical attention. If swallowed, do not induce vomiting; contact a physician immediately. Failure to comply may result in serious injury or death to personnel.

NOTE

Apply dielectric grease to all electrical connections.

Apply corrosion preventive compound on all nuts and bolts.

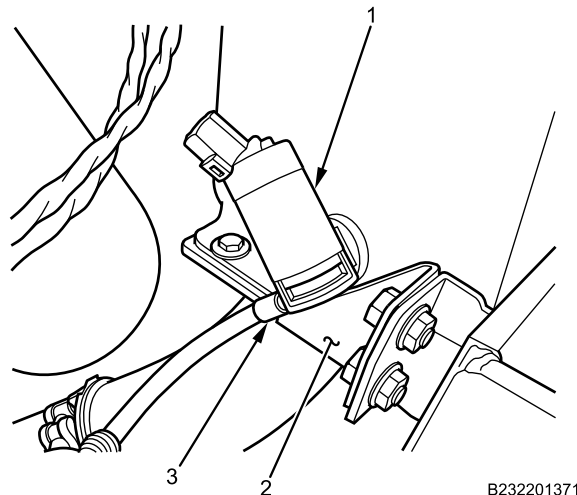

Figure 4. Windshield Washer Pump Hose.

1. Install windshield washer reservoir and pump assembly on windshield washer and pump assembly bracket (Figure 4, Item 2).
2. Install windshield washer hose (Figure 4, Item 3) on windshield washer pump (Figure 4, Item 1).

**WINDSHIELD WASHER RESERVOIR AND PUMP MOTOR ASSEMBLY REMOVAL AND INSTALLATION -
(CONTINUED)**

Figure 5. Windshield Washer Reservoir and Pump Motor.

3. Install four windshield washer reservoir and pump assembly bolts (Figure 5, Item 2 through 5) on windshield washer reservoir and pump assembly (Figure 5, Item 1).
4. Torque windshield washer reservoir and pump assembly bolts (Figure 5, Item 2 through 5) to 142 lb-in. (16 N•m).

**WINDSHIELD WASHER RESERVOIR AND PUMP MOTOR ASSEMBLY REMOVAL AND INSTALLATION -
(CONTINUED)**

B232201370

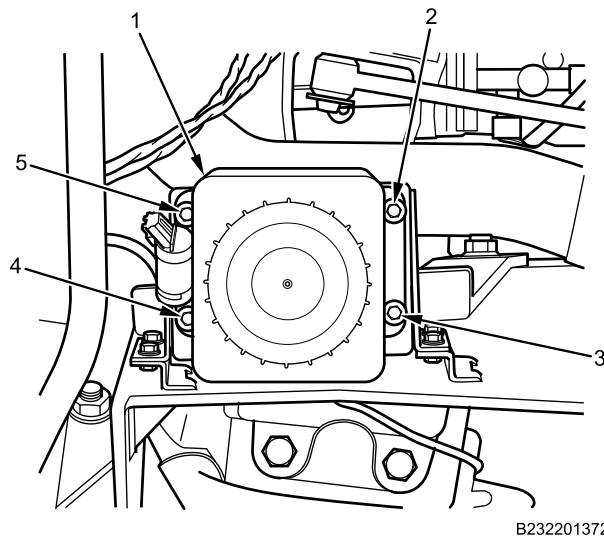
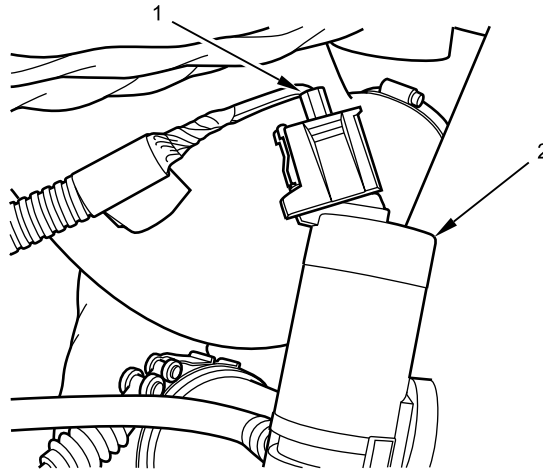
Figure 6. Windshield Washer Pump Harness Connector.

5. Install windshield washer pump wiring harness connector (Figure 6, Item 1) on windshield washer pump (Figure 6, Item 2).

NOTE

If windshield washer fluid was saved in a clean drain pan during removal, use saved fluid to refill windshield washer reservoir.

6. Refill windshield washer fluid reservoir (TM 9-2355-106-10).

END OF TASK**FOLLOW-ON MAINTENANCE**

1. Refill windshield washer fluid reservoir (TM 9-2355-106-10).
2. Close engine hood (TM 9-2355-106-10).
3. Turn MAIN POWER switch on (TM 9-2355-106-10).
4. Verify windshield washer reservoir and pump motor operation (TM 9-2355-106-10).
5. Turn MAIN POWER switch off (TM 9-2355-106-10).
6. Remove wheel chocks (TM 9-2355-106-10).

END OF TASK**END OF WORK PACKAGE**

FIELD MAINTENANCE

WINDSHIELD WASHER HOSE ASSEMBLY REMOVAL AND INSTALLATION

INITIAL SETUP:

Tools and Special Tools

General Mechanic's Tool Kit (GMTK)
(WP 0795, Item 37)

Materials/Parts

Cable lock strap - (2) (WP 0796, Item 124)

References

TM 9-2355-106-10
TM 9-2355-106-23P

WP 0782

Equipment Condition

Parking brake set (TM 9-2355-106-10)
Transmission set in NEUTRAL (N) (TM
9-2355-106-10)
Engine off (TM 9-2355-106-10)
MAIN POWER switch off (TM 9-2355-106-10)
Wheels chocked (TM 9-2355-106-10)
Wiper cowl panel removed (WP 0683)

NOTE

Remove cable lock straps as necessary to perform procedure. Note position and size of cable lock straps to aid installation.

REMOVAL

1. Remove windshield washer pump hose (Figure 1, Item 3) from center cowl support brackets (Figure 1, Item 1 and 2).

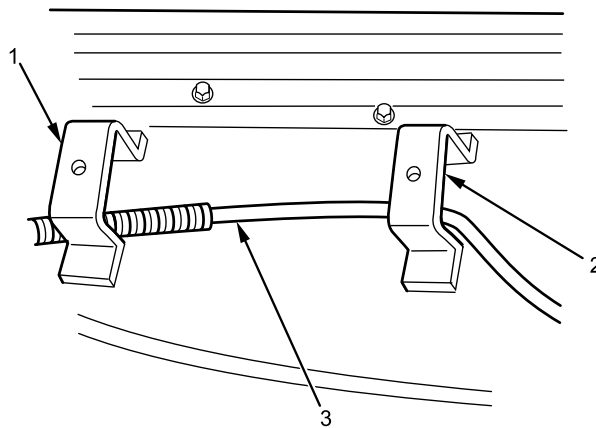

B232201382

Figure 1. Windshield Washer Pump Hose Routing.

WINDSHIELD WASHER HOSE ASSEMBLY REMOVAL AND INSTALLATION - (CONTINUED)

2. Remove windshield washer pump hose (Figure 2, Item 2) from left cowl support bracket (Figure 2, Item 3), left antenna support bracket (Figure 2, Item 1), and antenna ground strap (Figure 2, Item 4).

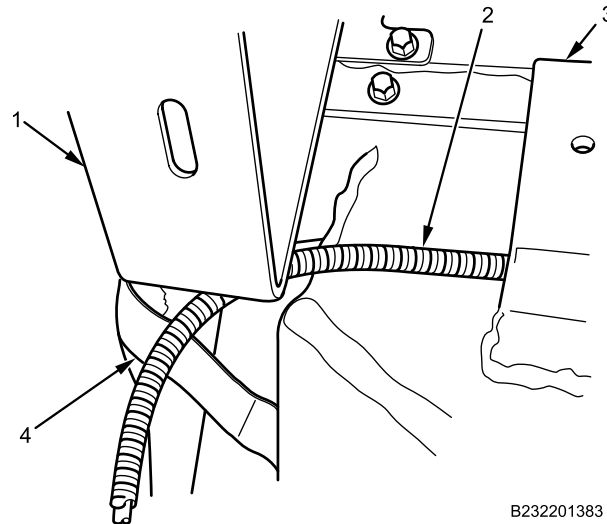

Figure 2. Windshield Washer Pump Hose Routing.

3. Remove windshield washer pump hose (Figure 3, Item 2) from antenna ground strap (Figure 3, Item 1), A-pillar (Figure 3, Item 4), and hood bumper stop (Figure 3, Item 3).

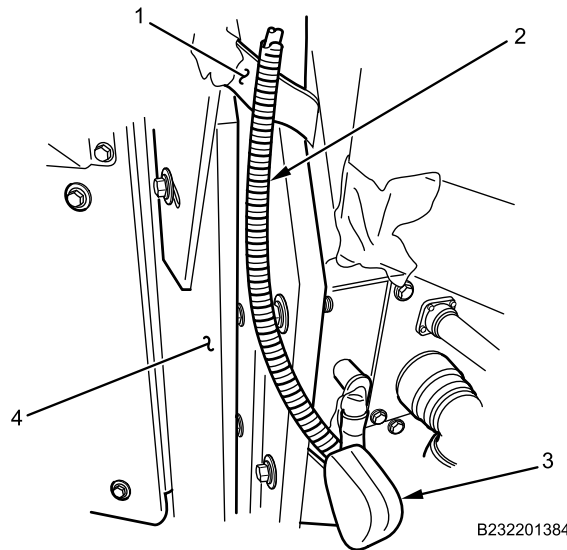
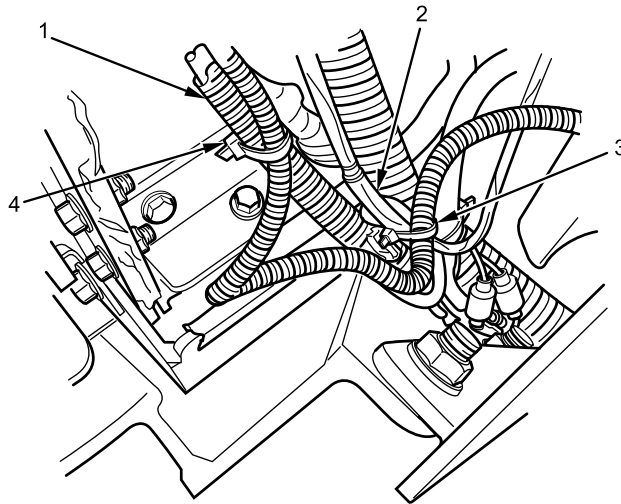

Figure 3. Windshield Washer Pump Hose Routing.

WINDSHIELD WASHER HOSE ASSEMBLY REMOVAL AND INSTALLATION - (CONTINUED)

4. Remove windshield washer pump hose cable lock straps (Figure 4, Item 3 and 4) from wiring harnesses (Figure 4, Item 1 and 2). Discard cable lock straps.



B232201385

Figure 4. Windshield Washer Pump Hose Routing.

5. Remove windshield washer pump hose (Figure 5, Item 1) from windshield washer pump fitting (Figure 5, Item 2).

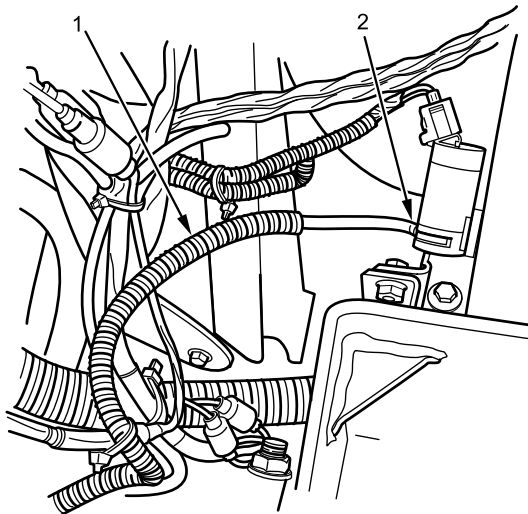

B232201386

Figure 5. Windshield Washer Pump Hose to Washer Pump.

END OF TASK

WINDSHIELD WASHER HOSE ASSEMBLY REMOVAL AND INSTALLATION - (CONTINUED)**INSTALLATION**

1. Install windshield washer pump hose (Figure 6, Item 1) on windshield washer pump fitting (Figure 6, Item 2).

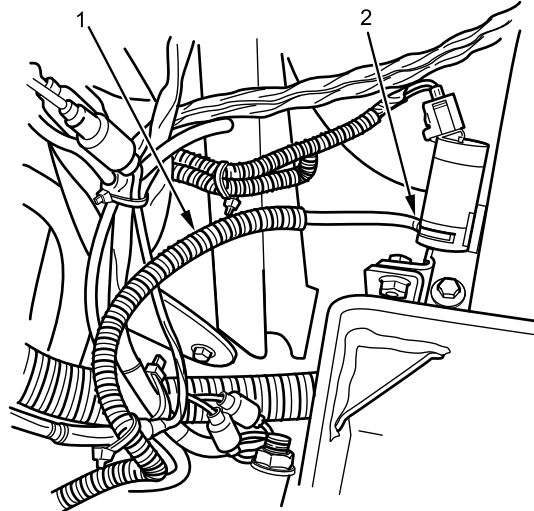

B232201386

Figure 6. Windshield Washer Pump Hose to Washer Pump.

2. Install new windshield washer pump hose cable lock straps (Figure 7, Item 3 and 4) on wiring harnesses (Figure 7, Item 1 and 2).

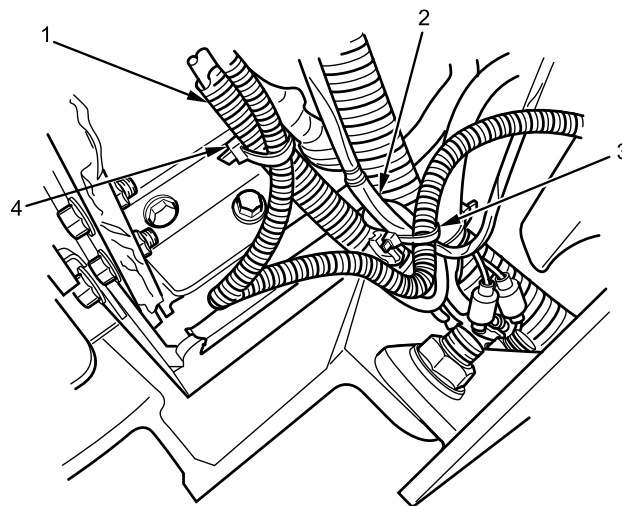

B232201385

Figure 7. Windshield Washer Pump Hose Routing.

WINDSHIELD WASHER HOSE ASSEMBLY REMOVAL AND INSTALLATION - (CONTINUED)

3. Install windshield washer pump hose (Figure 8, Item 2) on antenna ground strap (Figure 8, Item 1), A-pillar (Figure 8, Item 4), and hood bumper stop (Figure 8, Item 3).

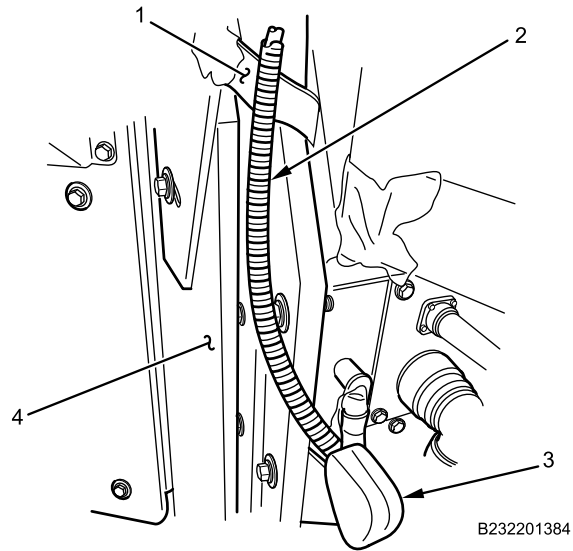

Figure 8. Windshield Washer Pump Hose Routing.

4. Install windshield washer pump hose (Figure 9, Item 2) on left cowl support bracket (Figure 9, Item 3), left antenna support bracket (Figure 9, Item 1), and antenna ground strap (Figure 9, Item 4).

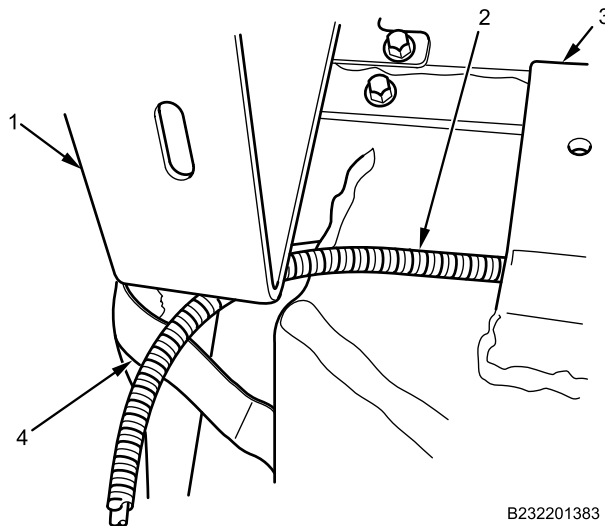
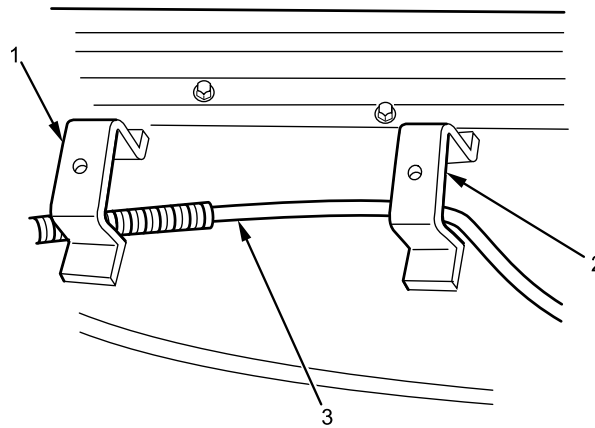

Figure 9. Windshield Washer Pump Hose Routing.

WINDSHIELD WASHER HOSE ASSEMBLY REMOVAL AND INSTALLATION - (CONTINUED)

5. Install windshield washer pump hose (Figure 10, Item 3) on center cowl support brackets (Figure 10, Item 1 and 2).



B232201382

Figure 10. Windshield Washer Pump Hose Routing.

6. Install all cable lock straps and tighten securely.

END OF TASK**FOLLOW-ON MAINTENANCE**

1. Install wiper cowl panel (WP 0683).
2. Turn MAIN POWER switch on (TM 9-2355-106-10).
3. Verify windshield washer and windshield wiper arm and blade assemblies operation (TM 9-2355-106-10).
4. Turn MAIN POWER switch off (TM 9-2355-106-10).
5. Remove wheel chocks (TM 9-2355-106-10).

END OF TASK**END OF WORK PACKAGE**

FIELD MAINTENANCE
WINDSHIELD WASHER RESERVOIR BRACKET REMOVAL AND INSTALLATION

INITIAL SETUP:**Tools and Special Tools**

General Mechanic's Tool Kit (GMTK)
(WP 0795, Item 37)
Wrench, torque, dial, 300 lb-in., 3/8-inch drive
(WP 0795, Item 147)

TM 9-2355-106-23P
WP 0782

Equipment Condition

Parking brake set (TM 9-2355-106-10)
Transmission set in NEUTRAL (N) (TM
9-2355-106-10)
Engine off (TM 9-2355-106-10)
MAIN POWER switch off (TM 9-2355-106-10)
Wheels chocked (TM 9-2355-106-10)
Engine hood open and secure (TM 9-2355-106-10)
Battery cables disconnected (WP 0404)
Windshield washer reservoir removed (WP 0686)

Materials/Parts

Compound (WP 0794, Item 13)
Goggles, industrial (WP 0794, Item 20)
Faceshield, industrial (WP 0794, Item 16)
Gloves (WP 0794, Item 18)

References

TM 9-2355-106-10

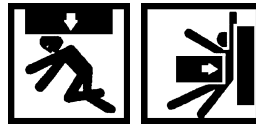
WARNING

Engine hood is extremely heavy and requires two-person lift. Ensure that there is adequate space in front of the vehicle to open hood completely without pinning or pinching personnel between hood and any other structure. Use extreme care when working under hood and make sure it is properly supported. Failure to comply may result in serious injury or death to personnel.

WINDSHIELD WASHER RESERVOIR BRACKET REMOVAL AND INSTALLATION - (CONTINUED)**REMOVAL**

1. Remove windshield washer reservoir bracket bolts and flat washers (Figure 1, Item 1, 2, 3, and 5) from windshield washer reservoir bracket (Figure 1, Item 4) and remove bracket.

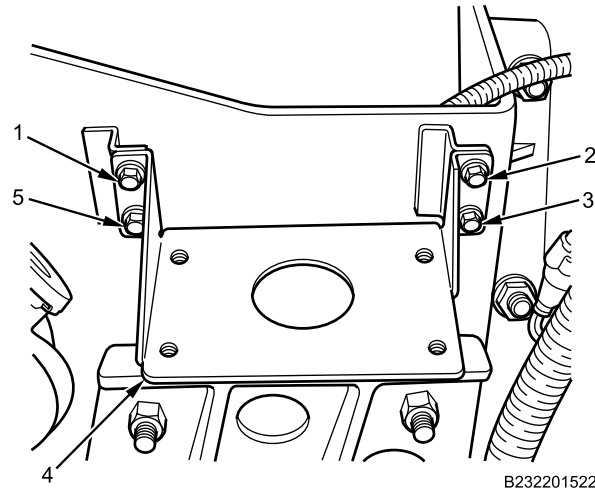

Figure 1. Windshield Washer Reservoir Bracket.

END OF TASK**INSTALLATION****WARNING**

Corrosion preventive compound is toxic. Use only in well-ventilated area. Do not get in eyes; wear chemical safety goggles and full-face shield when using. Avoid contact with skin and wear rubber or plastic, solvent-resistant gloves. In case of contact, remove contaminated clothing and immediately wash area with soap and water. If compound contacts eyes, flush eyes with large amounts of water for at least 15 minutes and get immediate medical attention. If swallowed, do not induce vomiting; contact a physician immediately. Failure to comply may result in serious injury or death to personnel.

1. Apply corrosion preventive compound to windshield washer reservoir bracket bolts (Figure 2, Item 1, 2, 3, and 5).

WINDSHIELD WASHER RESERVOIR BRACKET REMOVAL AND INSTALLATION - (CONTINUED)

Figure 2. Windshield Washer Reservoir Bracket.

2. Position windshield washer reservoir bracket (Figure 2, Item 4) and install with windshield washer reservoir bracket bolts and flat washers (Figure 2, Item 1, 2, 3, and 5).
3. Torque windshield washer reservoir bracket bolts (Figure , Item 1, 2, 3, and 5) to 283 lb-in. (32 N•m).

END OF TASK**FOLLOW-ON MAINTENANCE**

1. Install windshield washer reservoir (WP 0686).
2. Connect battery cables (WP 0404).
3. Close and secure engine hood (TM 9-2355-106-10).
4. Turn MAIN POWER switch on (TM 9-2355-106-10).
5. Verify windshield washer reservoir operation (TM 9-2355-106-10).
6. Turn MAIN POWER switch off (TM 9-2355-106-10).
7. Remove wheel chocks (TM 9-2355-106-10).

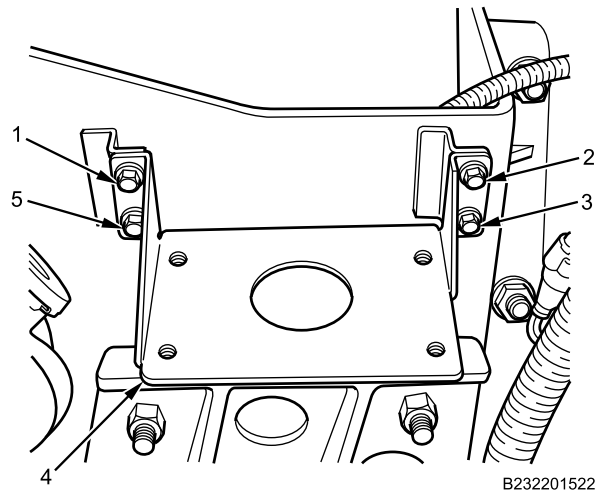
END OF TASK**END OF WORK PACKAGE**

FIELD MAINTENANCE
WINDSHIELD WIPER MOTOR HARNESS REMOVAL AND INSTALLATION

INITIAL SETUP:**Tools and Special Tools**

General Mechanic's Tool Kit (GMTK)
(WP 0795, Item 37)

WP 0782

Equipment Condition

Parking brake set (TM 9-2355-106-10)
Transmission set in NEUTRAL (N) (TM
9-2355-106-10)
Engine off (TM 9-2355-106-10)
MAIN POWER switch off (TM 9-2355-106-10)
Wheels chocked (TM 9-2355-106-10)
Engine hood open and secured (TM 9-2355-106-10)
Wiper cowl panel removed (WP 0683)

Materials/Parts

Grease (WP 0794, Item 22)
Cable lock strap (WP 0796, Item 104)
Cable lock strap - (3) (WP 0796, Item 124)

References

TM 9-2355-106-10
TM 9-2355-106-23P

WARNING

Use extreme caution when testing or working on or around electrical circuits. Always assume that electrical circuits are live. Electrical shock can occur upon contact with voltage high enough to cause current flow through muscles or nerves. On Direct Current (DC) systems, generally 1 milliamp of current can be felt, 5 milliamps can cause severe pain, 15 milliamps can cause loss of muscle control, and 70 milliamps can be fatal. Wear protective clothing; ensure skin, clothing, and surrounding areas are dry; do not wear jewelry; and touch only the insulated, nonmetallic parts of electrical components and testing equipment. To prevent electrical arcing, avoid shorting electrical test probes and jumper wires. Electrical arcing can cause bright flashes of light, capable of causing temporary blindness. If electrical injury occurs, immediately shut off power supply and seek medical assistance. Failure to comply may result in serious injury or death to personnel.

WINDSHIELD WIPER MOTOR HARNESS REMOVAL AND INSTALLATION - (CONTINUED)

REMOVAL

1. Remove power distribution center (PDC) armor clips (Figure 1, Item 1 and 3) and armor plate (Figure 1, Item 2).

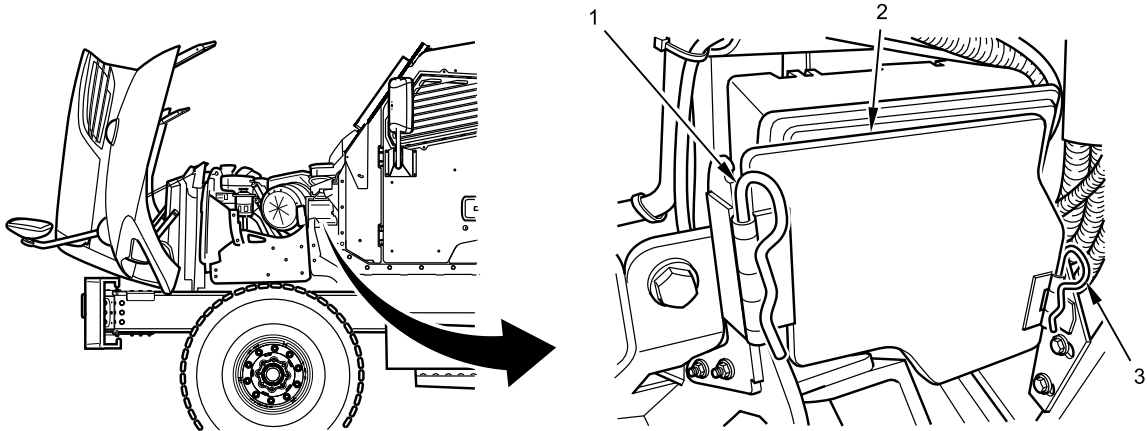

B230601937

Figure 1. Power Distribution Center (PDC) Armor Plate.

2. At lower end of windshield wiper motor harness (below power distribution center [PDC]), remove windshield wiper motor harness cable lock strap (Figure 2, Item 3) from windshield wiper motor harness connector (Figure 2, Item 2). Discard windshield wiper harness cable lock strap.

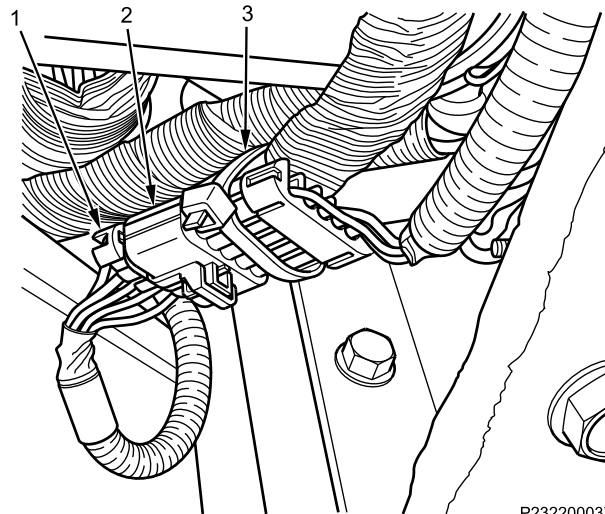

P232200037

Figure 2. Windshield Wiper Motor Harness Connector.

3. Disconnect windshield wiper motor harness connector (Figure 2, Item 2) from chassis harness connector (Figure 2, Item 1).

WINDSHIELD WIPER MOTOR HARNESS REMOVAL AND INSTALLATION - (CONTINUED)

4. Remove cable lock strap (Figure 3, Item 3) from windshield wiper motor harness (Figure 3, Item 2) next to bulkhead connector (Figure 3, Item 1). Discard cable lock strap.

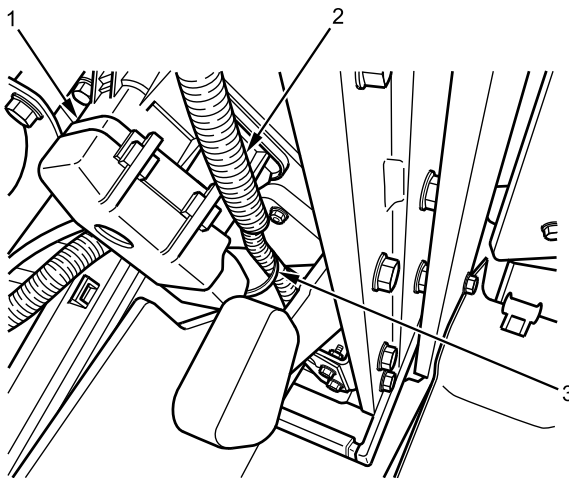

B232203465

Figure 3. Windshield Wiper Motor Harness Routing On Bulkhead.

5. Remove cable lock strap (Figure 4, Item 3) from windshield wiper motor harness (Figure 4, Item 1) and left cowl support bracket (Figure 4, Item 2). Discard cable lock strap.

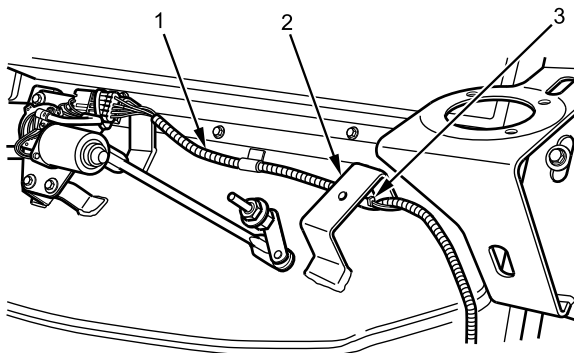

B232203466

Figure 4. Windshield Wiper Motor Harness Routing On Cowl.

WINDSHIELD WIPER MOTOR HARNESS REMOVAL AND INSTALLATION - (CONTINUED)

6. Remove cable lock strap (Figure 5, Item 2) from windshield wiper motor harness connector (Figure 5, Item 3) and windshield wiper motor bracket (Figure 5, Item 1). Discard cable lock strap.

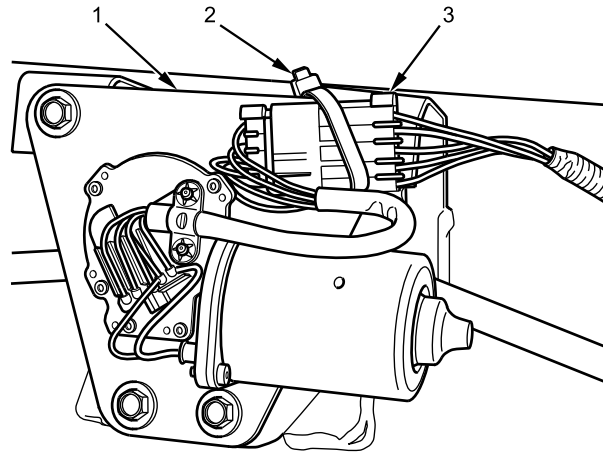

P231800036

Figure 5. Windshield Wiper Motor Harness Cable Lock Strap.

7. Release connector lock tab (Figure 6, Item 2) and disconnect windshield wiper motor harness connector (Figure 6, Item 3) from windshield wiper motor connector (Figure 6, Item 1). Remove windshield wiper motor harness from vehicle.

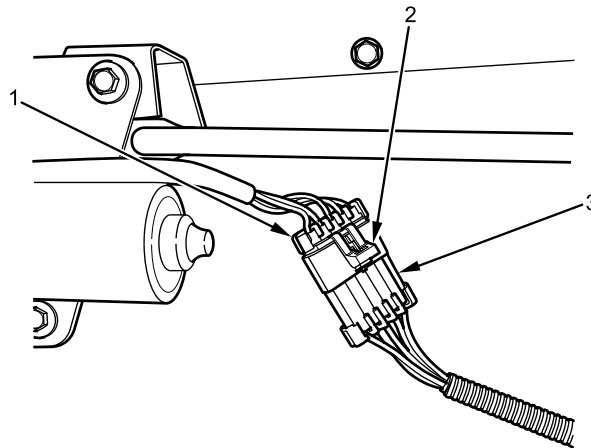

B232201394

Figure 6. Windshield Wiper Motor Harness Connection.

END OF TASK

WINDSHIELD WIPER MOTOR HARNESS REMOVAL AND INSTALLATION - (CONTINUED)**INSTALLATION****WARNING**

Dielectric grease is harmful to skin and eyes. If grease contacts eyes, rinse thoroughly and contact physician if irritation persists. If skin is contacted, wash thoroughly with soap and water. Failure to comply may result in serious injury to personnel.

NOTE

Apply dielectric grease to all electrical connections.

1. Connect windshield wiper motor harness connector (Figure 7, Item 3) to windshield wiper motor connector (Figure 7, Item 1) and engage connector lock tab (Figure 7, Item 2).

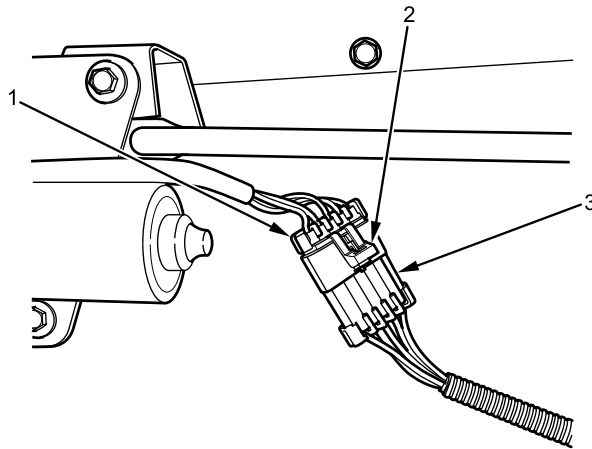

B232201394

Figure 7. Windshield Wiper Motor Harness Connection.

WINDSHIELD WIPER MOTOR HARNESS REMOVAL AND INSTALLATION - (CONTINUED)

2. Position windshield wiper motor harness connector (Figure 8, Item 3) on bracket (Figure 8, Item 1) and install new cable lock strap (Figure 8, Item 2).

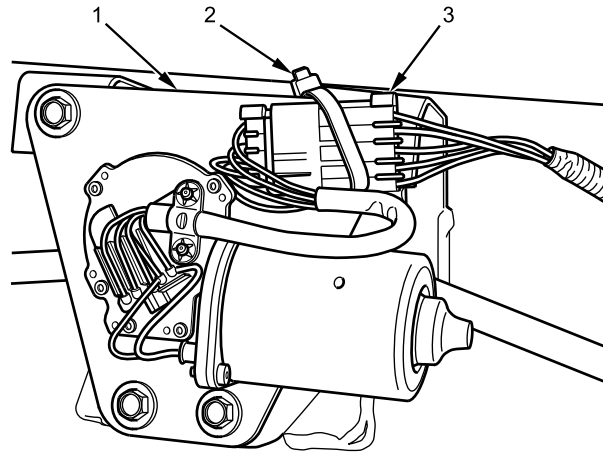

P231800036

Figure 8. Windshield Wiper Motor Harness Cable Lock Strap.

3. Route windshield wiper motor harness (Figure 9, Item 1) through left cowl support bracket (Figure 9, Item 2) and install a new cable lock strap (Figure 9, Item 3).

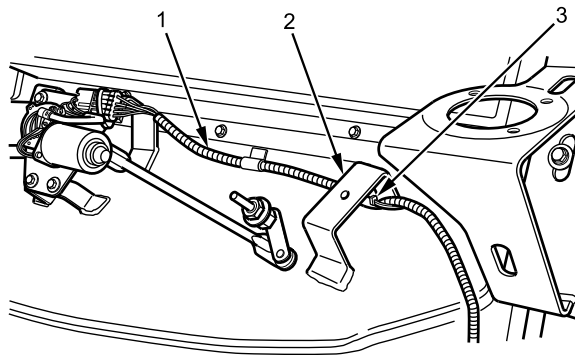

B232203466

Figure 9. Windshield Wiper Motor Harness Routing On Cowl.

WINDSHIELD WIPER MOTOR HARNESS REMOVAL AND INSTALLATION - (CONTINUED)

4. Position windshield wiper motor harness (Figure 10, Item 2) next to bulkhead connector (Figure 10, Item 1) and install new cable lock strap (Figure 10, Item 3).

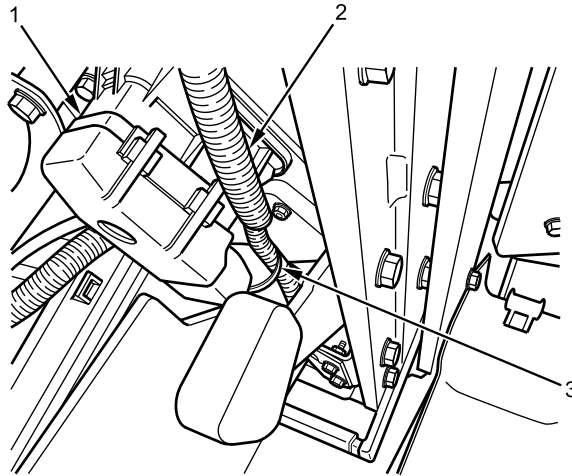

B232203465

Figure 10. Windshield Wiper Motor Harness Routing On Bulkhead.

5. Connect windshield wiper motor harness connector (Figure 11, Item 2) to chassis harness connector (Figure 11, Item 1) and install new cable lock strap (Figure 11, Item 3).

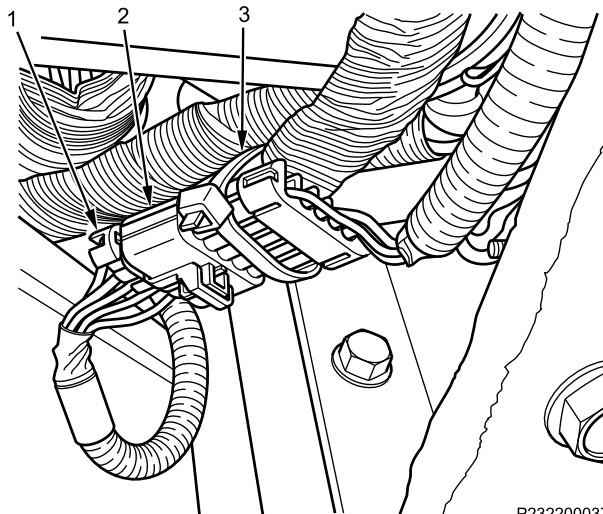

P232200037

Figure 11. Windshield Wiper Motor Harness Connector.

WINDSHIELD WIPER MOTOR HARNESS REMOVAL AND INSTALLATION - (CONTINUED)

6. Install PDC armor plate (Figure 12, Item 2) and install armor plate clips (Figure 12, Item 1 and 3).

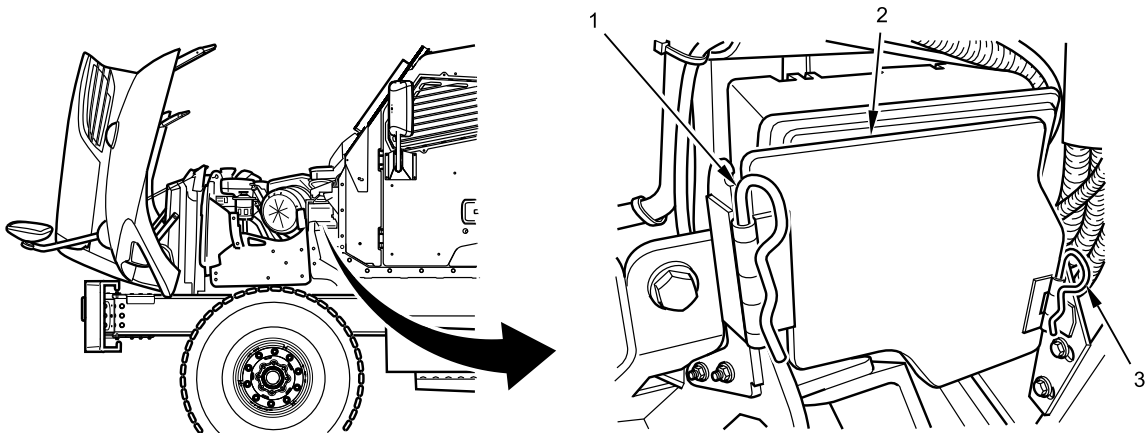

B230601937

Figure 12. PDC Armor Plate.

END OF TASK**FOLLOW-ON MAINTENANCE**

1. Install wiper cowl panel (WP 0683).
2. Turn battery disconnect switch on (TM 9-2355-106-10).
3. Verify operation of windshield washer and windshield wiper arm and blade assemblies (TM 9-2355-106-10).
4. Turn MAIN POWER switch off (TM 9-2355-106-10).
5. Close and secure engine hood (TM 9-2355-106-10).
6. Remove wheel chocks (TM 9-2355-106-10).

END OF TASK**END OF WORK PACKAGE**

FIELD MAINTENANCE
REAR DOOR/RAMP HYDRAULIC PUMP COVER REMOVAL AND INSTALLATION (PUSH-TYPE OPERATION)

INITIAL SETUP:**Tools and Special Tools**

General Mechanic's Tool Kit (GMTK)
(WP 0795, Item 37)

TM 9-2355-106-23P

WP 0786

WP 0782

Materials/Parts

Faceshield, industrial (WP 0794, Item 16)
Gloves (WP 0794, Item 18)
Goggles, industrial (WP 0794, Item 20)

Equipment Condition

Parking brake set (TM 9-2355-106-10)

Transmission set in NEUTRAL (N) (TM
9-2355-106-10)

Engine off (TM 9-2355-106-10)

MAIN POWER switch off (TM 9-2355-106-10)

Wheels chocked (TM 9-2355-106-10)

References

TM 9-2355-106-10

WARNING

Never touch any part of a hydraulic assembly before it is known that the system is depressurized. The rear door actuating system operates under high pressure. Pressurized hydraulic fluid can penetrate skin and body tissue. Contact with pressurized hydraulic fluid requires prompt medical attention, even if an injury is not evident. Failure to comply may result in serious injury, amputation, or death to personnel.

Hydraulic fluid is flammable and harmful to skin and eyes. Wear work gloves and eye protection when handling fluids. Do not perform maintenance while smoking or near flame or sparks. If fluid contacts skin, wash affected area immediately. In case of eye contact, flush with water for 15 minutes and seek medical care immediately. Dispose of hydraulic fluid in accordance with standard operating procedures. Failure to comply may result in serious injury to personnel.

**REAR DOOR/RAMP HYDRAULIC PUMP COVER REMOVAL AND INSTALLATION (PUSH-TYPE OPERATION)
- (CONTINUED)****REMOVAL****CAUTION**

Toggle switch can catch on pump cover. Ensure that toggle switch is free of pump cover before removing cover. Failure to comply may result in damage to equipment.

1. Remove nut from toggle switch (Figure 1, Item 1).

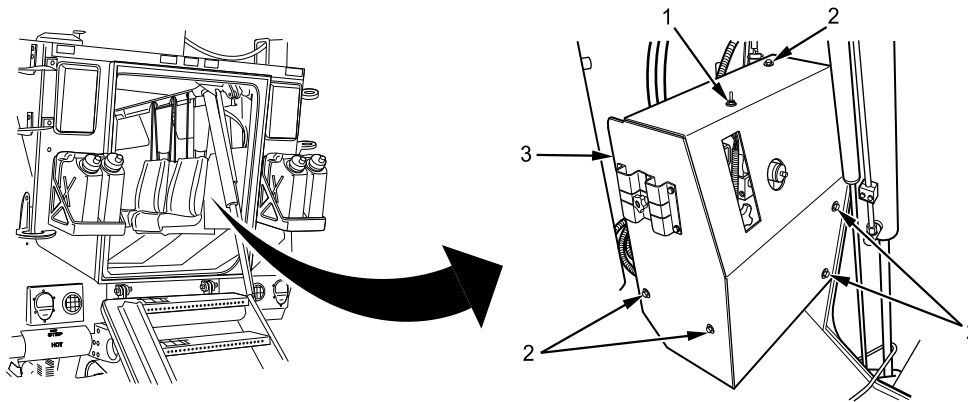

B232410628

Figure 1. Rear Door/Ramp Hydraulic Pump Cover.

2. Remove toggle switch (Figure 1, Item 1) from pump cover (Figure 1, Item 3).
3. Remove five pump cover bolts (Figure 1, Item 2) from pump cover (Figure 1, Item 3).
4. Remove pump cover (Figure 1, Item 3) from pump assembly.

END OF TASK

**REAR DOOR/RAMP HYDRAULIC PUMP COVER REMOVAL AND INSTALLATION (PUSH-TYPE OPERATION)
- (CONTINUED)****INSTALLATION**

1. Install toggle switch (Figure 2, Item 1) on pump cover (Figure 2, Item 1). Do not tighten.

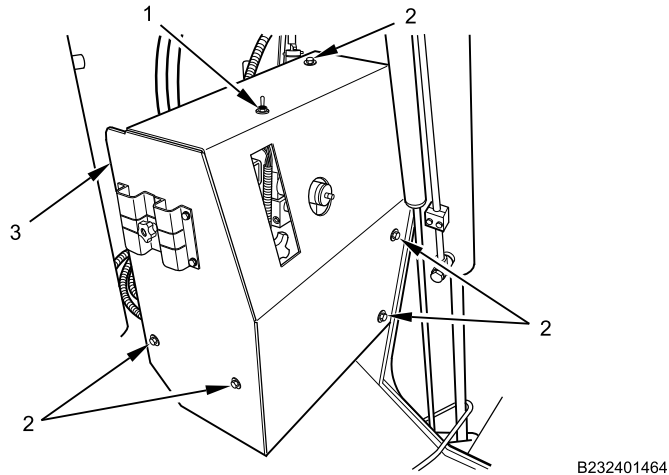

Figure 2. Rear Door/Ramp Hydraulic Pump Cover.

2. Install pump cover (Figure 2, Item 3) over pump assembly.
3. Install five pump cover bolts (Figure 2, Item 2) to pump cover (Figure 2, Item 3) and tighten securely.
4. Tighten toggle switch nut securely.

END OF TASK**FOLLOW-ON MAINTENANCE**

1. Remove wheel chocks (TM 9-2355-106-10).

END OF TASK**END OF WORK PACKAGE**

FIELD MAINTENANCE**REAR DOOR/RAMP HYDRAULIC PUMP COVER REMOVAL AND INSTALLATION (PULL-TYPE OPERATION)**

INITIAL SETUP:**Tools and Special Tools**

General Mechanic's Tool Kit (GMTK)
(WP 0795, Item 37)

References

TM 9-2355-106-10
TM 9-2355-106-23P
WP 0786
WP 0782

Equipment Condition

Parking brake set (TM 9-2355-106-10)
Transmission set in NEUTRAL (N) (TM
9-2355-106-10)
Engine off (TM 9-2355-106-10)
MAIN POWER switch off (TM 9-2355-106-10)
Wheels chocked (TM 9-2355-106-10)

WARNING

Never touch any part of a hydraulic assembly before it is known that the system is depressurized. The rear door actuating system operates under high pressure. Pressurized hydraulic fluid can penetrate skin and body tissue. Contact with pressurized hydraulic fluid requires prompt medical attention, even if an injury is not evident. Failure to comply may result in serious injury, amputation, or death to personnel.

Use extreme caution when testing or working on or around electrical circuits. Always assume that electrical circuits are live. Electrical shock can occur upon contact with voltage high enough to cause current flow through muscles or nerves. On Direct Current (DC) systems, generally 1 milliamp of current can be felt, 5 milliamps can cause severe pain, 15 milliamps can cause loss of muscle control, and 70 milliamps can be fatal. Wear protective clothing; ensure skin, clothing, and surrounding areas are dry; do not wear jewelry; and touch only the insulated, nonmetallic parts of electrical components and testing equipment. To prevent electrical arcing, avoid shorting electrical test probes and jumper wires. Electrical arcing can cause bright flashes of light, capable of causing temporary blindness. If electrical injury occurs, immediately shut off power supply and seek medical assistance. Failure to comply may result in serious injury or death to personnel.

REAR DOOR/RAMP HYDRAULIC PUMP COVER REMOVAL AND INSTALLATION (PULL-TYPE OPERATION) - (CONTINUED)

REMOVAL

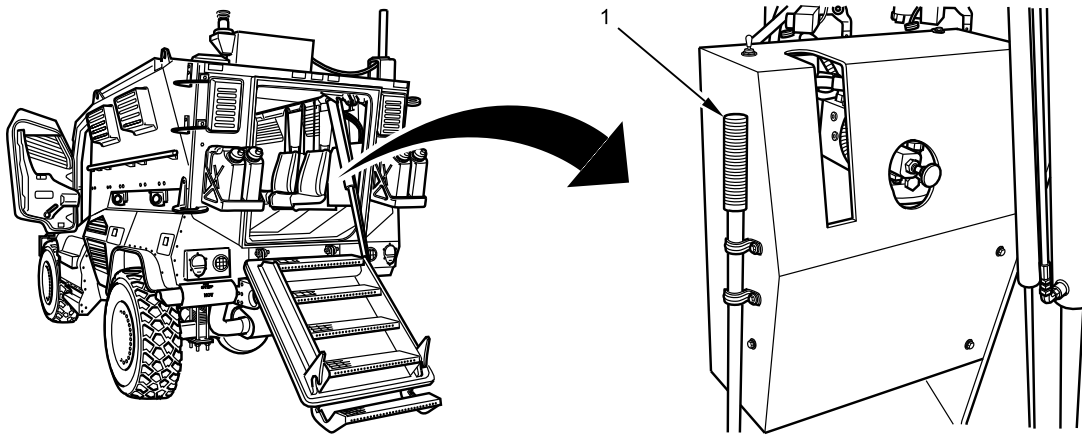

B231805906

Figure 1. Removing Pump Handle.

1. Remove manual hand pump handle (Figure 1, Item 1) from hydraulic pump cover.

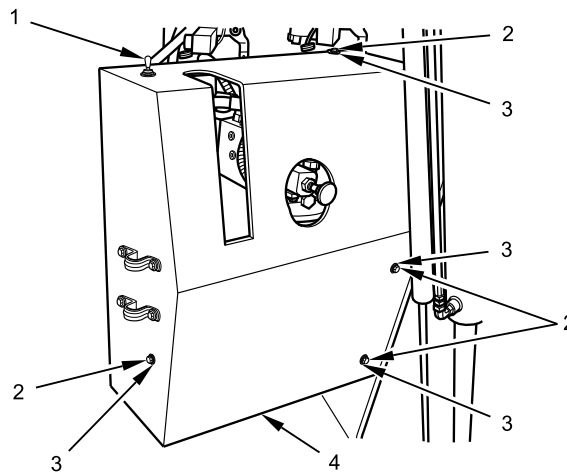

B231805908

Figure 2. Rear Door/Ramp Hydraulic Pump Cover Removal.

CAUTION

Toggle switch can catch on pump cover. Ensure that toggle switch is free of pump cover before removing cover. Failure to comply may result in damage to equipment.

NOTE

Left side inner bolt not shown.

2. Remove nut and toggle switch (Figure 2, Item 1) from hydraulic pump cover (Figure 2, Item 4).
3. Remove five bolts (Figure 2, Item 2) and washers (Figure 2, Item 3) from hydraulic pump cover (Figure 2, Item 4).
4. Remove hydraulic pump cover (Figure 2, Item 4) from hydraulic pump assembly.

END OF TASK

**REAR DOOR/RAMP HYDRAULIC PUMP COVER REMOVAL AND INSTALLATION (PULL-TYPE OPERATION)
- (CONTINUED)****INSTALLATION****NOTE**

Left side inner bolt not shown.

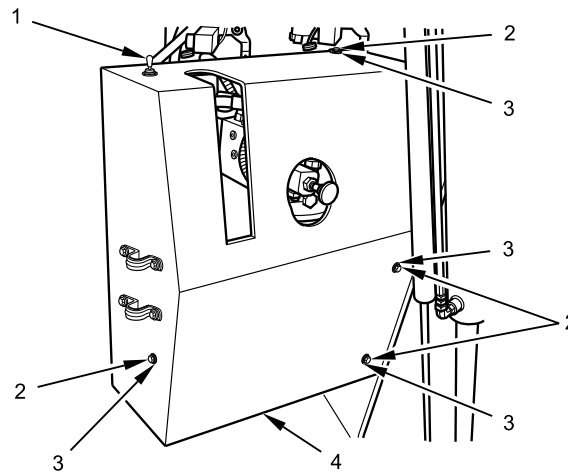

B231805908

Figure 3. Rear Door/Ramp Hydraulic Pump Cover Installation.

1. Install hydraulic pump cover (Figure 3, Item 4) on hydraulic pump assembly with five bolts (Figure 3, Item 2) and washers (Figure 3, Item 3). Tighten securely.
2. Install toggle switch (Figure 3, Item 1) on hydraulic pump cover (Figure 3, Item 4) with nut. Tighten securely.

**REAR DOOR/RAMP HYDRAULIC PUMP COVER REMOVAL AND INSTALLATION (PULL-TYPE OPERATION)
- (CONTINUED)**

3. Install manual hand pump handle (Figure 4, Item 1) on hydraulic pump cover.

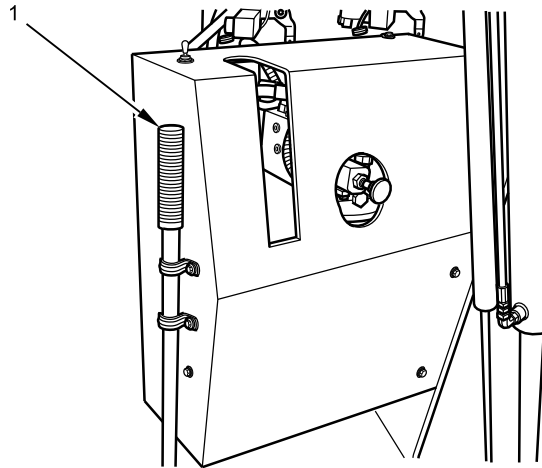

B231805907

Figure 4. Installing Pump Handle.

END OF TASK**FOLLOW-ON MAINTENANCE**

1. Remove wheel chocks (TM 9-2355-106-10).

END OF TASK**END OF WORK PACKAGE**

FIELD MAINTENANCE**REAR DOOR/RAMP HYDRAULIC PUMP REMOVAL AND INSTALLATION (PUSH-TYPE OPERATION)**

INITIAL SETUP:**Tools and Special Tools**

General Mechanic's Tool Kit (GMTK)
(WP 0795, Item 37)
Pan, drain, 5-gal. capacity (WP 0795, Item 75)

TM 9-2355-106-23P

WP 0786

WP 0782

Materials/Parts

Compound (WP 0794, Item 13)
Faceshield, industrial (WP 0794, Item 16)
Gloves (WP 0794, Item 18)
Goggles, industrial (WP 0794, Item 20)
Grease (WP 0794, Item 22)
Rag (WP 0794, Item 39)
Tag, marker (WP 0794, Item 49)
Lockwashers - (2) (WP 0796, Item 174)

Equipment Condition

Parking brake set (TM 9-2355-106-10)
Transmission set in NEUTRAL (N) (TM
9-2355-106-10)
Engine off (TM 9-2355-106-10)
MAIN POWER switch off (TM 9-2355-106-10)
Wheels chocked (TM 9-2355-106-10)
Rear door/ramp hydraulic pump cover removed
(WP 0690)
Rear door/ramp hydraulic hand pump removed
(WP 0694)

ReferencesTM 9-2355-106-10

REAR DOOR/RAMP HYDRAULIC PUMP REMOVAL AND INSTALLATION (PUSH-TYPE OPERATION) - (CONTINUED)

WARNING



Never touch any part of a hydraulic assembly before it is known that the system is depressurized. The rear door actuating system operates under high pressure. Pressurized hydraulic fluid can penetrate skin and body tissue. Contact with pressurized hydraulic fluid requires prompt medical attention, even if an injury is not evident. Failure to comply may result in serious injury, amputation, or death to personnel.

Check for hydraulic leak location visually from at least an arm's length away and not within the path of the leak. If leak is suspected in a blind area, use scrap pieces of material such as cardboard or wood to check for location. Never use hand or other body parts. Failure to comply may result in serious injury, amputation, or death to personnel.

Hydraulic fluid is flammable and harmful to skin and eyes. Wear work gloves and eye protection when handling fluids. Do not perform maintenance while smoking or near flame or sparks. If fluid contacts skin, wash affected area immediately. In case of eye contact, flush with water for 15 minutes and seek medical care immediately. Dispose of hydraulic fluid in accordance with standard operating procedures. Failure to comply may result in serious injury to personnel.

Dispose of used parts, rags, containers, and engine fluids in accordance with standard operating procedures. Failure to comply may result in serious injury to personnel.

Use extreme caution when testing or working on or around electrical circuits. Always assume that electrical circuits are live. Electrical shock can occur upon contact with voltage high enough to cause current flow through muscles or nerves. On Direct Current (DC) systems, generally 1 milliamp of current can be felt, 5 milliamps can cause severe pain, 15 milliamps can cause loss of muscle control, and 70 milliamps can be fatal. Wear protective clothing; ensure skin, clothing, and surrounding areas are dry; do not wear jewelry; and touch only the insulated, nonmetallic parts of electrical components and testing equipment. To prevent electrical arcing, avoid shorting electrical test probes and jumper wires. Electrical arcing can cause bright flashes of light, capable of causing temporary blindness. If electrical injury occurs, immediately shut off power supply and seek medical assistance. Failure to comply may result in serious injury or death to personnel.

Turn off ignition switch and MAIN POWER switch before performing electrical system maintenance. Failure to comply may result in serious injury or death to personnel.

NOTE

Identify all wire locations with tags before removal to aid installation.

REAR DOOR/RAMP HYDRAULIC PUMP REMOVAL AND INSTALLATION (PUSH-TYPE OPERATION) - (CONTINUED)

REMOVAL

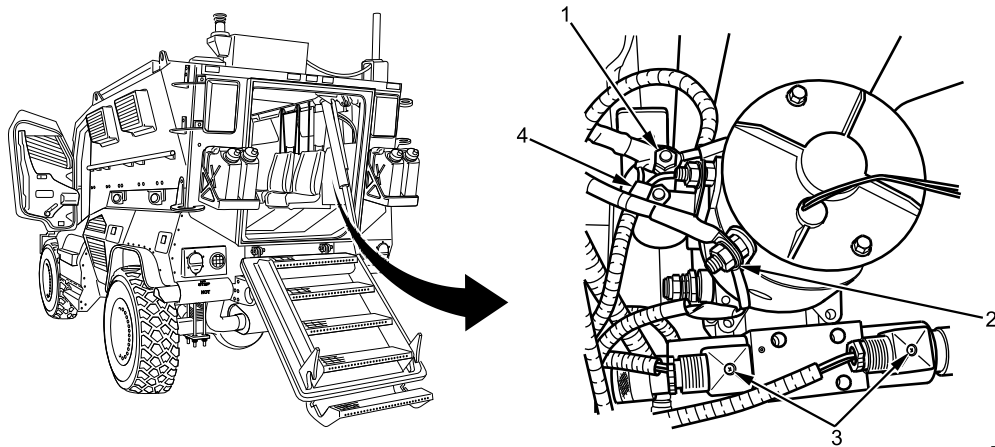

B231806022

Figure 1. Hydraulic Pump and Valve Assembly Electrical Connections.

1. Remove nut and ground cables from motor ground lug (Figure 1, Item 2).
2. Remove nut and battery cables from solenoid lug (Figure 1, Item 1).
3. Disconnect solenoid control wires from solenoid terminals (Figure 1, Item 4).
4. Remove connector retaining screws (Figure 1, Item 3) from hydraulic valve assembly and remove connectors.

NOTE

Identify all hose locations with wire tags before removal to aid installation.

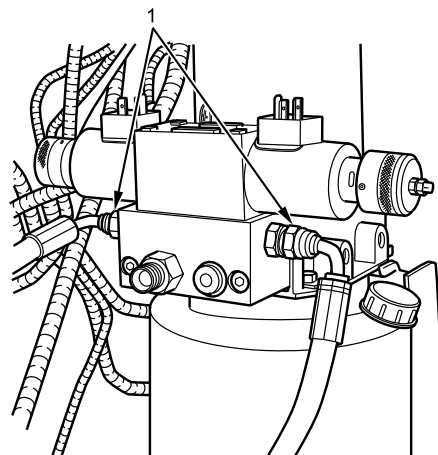

B232401494

Figure 2. Hydraulic Valve Assembly Hose Connections.

5. Place drain pan under rear door/ramp hydraulic pump.
6. Disconnect hydraulic hoses (Figure 2, Item 1) from unit.
7. Plug hose openings.

**REAR DOOR/RAMP HYDRAULIC PUMP REMOVAL AND INSTALLATION (PUSH-TYPE OPERATION) -
(CONTINUED)****NOTE**

To ease installation, mark the position of rear door/ramp hydraulic pump mounting bolts in relation to slotted mounting holes.

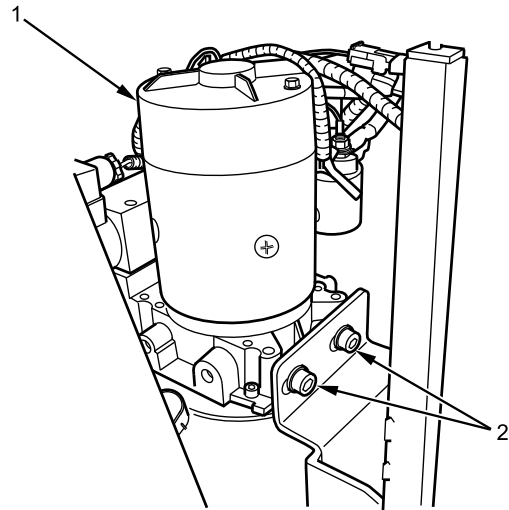

B232401493

Figure 3. Rear Door/Ramp Hydraulic Pump Mounting Bolts.

8. Remove rear door/ramp hydraulic pump mounting bolts (Figure 3, Item 2) and lockwashers. Discard lockwashers.
9. Remove rear door/ramp hydraulic pump (Figure 3, Item 1).

END OF TASK

**REAR DOOR/RAMP HYDRAULIC PUMP REMOVAL AND INSTALLATION (PUSH-TYPE OPERATION) -
(CONTINUED)****INSTALLATION****WARNING**

Corrosion preventive compound is toxic. Use only in well-ventilated area. Do not get in eyes; wear chemical safety goggles and full-face shield when using. Avoid contact with skin and wear rubber or plastic, solvent-resistant gloves. In case of contact, remove contaminated clothing and immediately wash area with soap and water. If compound contacts eyes, flush eyes with large amounts of water for at least 15 minutes and get immediate medical attention. If swallowed, do not induce vomiting; contact a physician immediately. Failure to comply may result in serious injury or death to personnel.

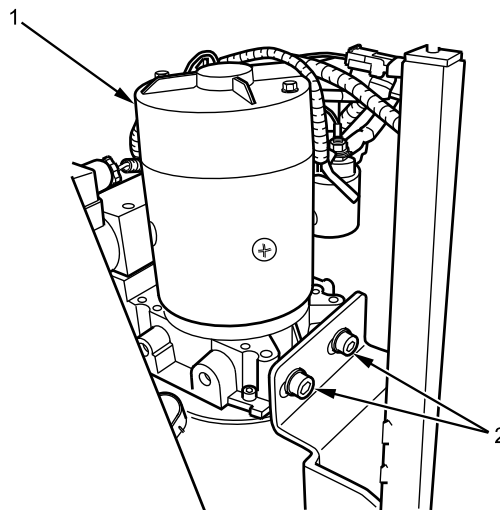

B232401493

Figure 4. Rear Door/Ramp Hydraulic Pump Mounting Bolts.

1. Apply corrosion preventive compound to rear door/ramp hydraulic pump mounting bolts (Figure 4, Item 2).
2. Align rear door/ramp hydraulic pump (Figure 4, Item 1) with markings on slotted mounting holes and install with two mounting bolts (Figure , Item 2) and two new lockwashers. Tighten securely.

REAR DOOR/RAMP HYDRAULIC PUMP REMOVAL AND INSTALLATION (PUSH-TYPE OPERATION) - (CONTINUED)

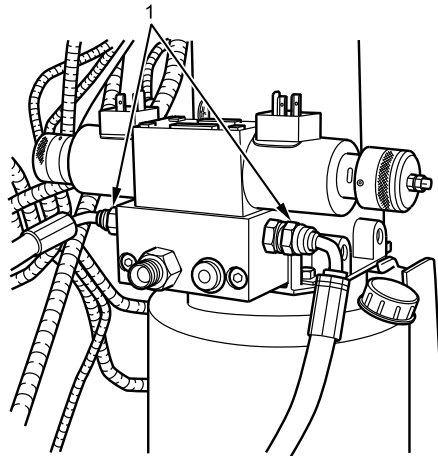

B232401494

Figure 5. Hydraulic Valve Assembly Hose Connections.

3. Connect hydraulic hoses (Figure 5, Item 1) to rear door/ramp hydraulic pump assembly. Tighten securely.

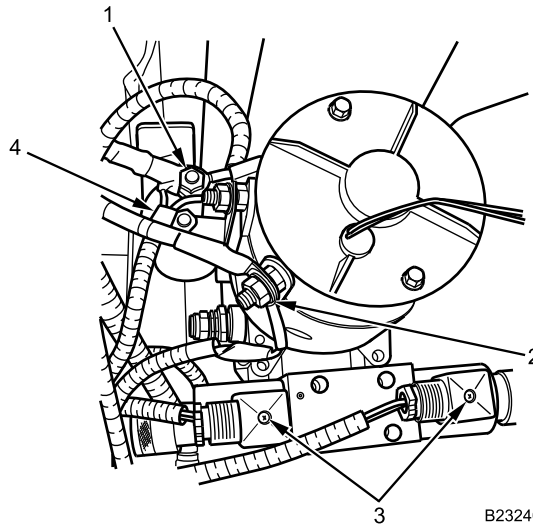

B232401495

Figure 6. Hydraulic Pump and Valve Assembly Electrical Connections.

WARNING



Dielectric grease is harmful to skin and eyes. If grease contacts eyes, rinse thoroughly and contact physician if irritation persists. If skin is contacted, wash thoroughly with soap and water. Failure to comply may result in serious injury to personnel.

4. Apply dielectric grease to all electrical connectors.
5. Connect solenoid control wires to solenoid terminals (Figure 6, Item 4).
6. Install battery cables and retaining nut on solenoid lug (Figure 6, Item 1). Tighten nut securely.
7. Install pump motor ground cable and retaining nut on motor ground lug (Figure 6, Item 2). Tighten securely.

REAR DOOR/RAMP HYDRAULIC PUMP REMOVAL AND INSTALLATION (PUSH-TYPE OPERATION) - (CONTINUED)

8. Connect hydraulic valve assembly electrical connectors (Figure 6, Item 3).
9. Install hydraulic valve assembly electrical connector retaining screws (Figure 6, Item 3) and tighten securely.
10. Remove drain pan.
11. Clean up all fluid spills with rag.

END OF TASK**FOLLOW-ON MAINTENANCE**

1. Install rear door/ramp hydraulic hand pump (WP 0694).
2. Install rear door/ramp hydraulic pump cover (WP 0690).
3. Turn MAIN POWER switch on (TM 9-2355-106-10).
4. Verify rear door/ramp operation (TM 9-2355-106-10).
5. Check hoses and connections for leaks.
6. Turn MAIN POWER switch off (TM 9-2355-106-10).
7. Remove wheel chocks (TM 9-2355-106-10).

END OF TASK**END OF WORK PACKAGE**

FIELD MAINTENANCE

REAR DOOR/RAMP HYDRAULIC PUMP REMOVAL AND INSTALLATION (PULL-TYPE OPERATION)

INITIAL SETUP:

Tools and Special Tools

General Mechanic's Tool Kit (GMTK) (WP 0795, Item 37)

TM 9-2355-106-23P
WP 0782

Materials/Parts

Goggles, industrial (WP 0794, Item 20)
Faceshield, industrial (WP 0794, Item 16)
Gloves (WP 0794, Item 18)
Compound (WP 0794, Item 13)
Lockwasher - (2) (WP 0796, Item 183)
Lockwasher - (2) (WP 0796, Item 184)
Wire tags (WP 0794, Item 33)

Equipment Condition

Parking brake set (TM 9-2355-106-10)
Transmission set in NEUTRAL (N) (TM 9-2355-106-10)
Engine off (TM 9-2355-106-10)
MAIN POWER switch off (TM 9-2355-106-10)
Wheels chocked (TM 9-2355-106-10)
Batteries disconnected (WP 0404)
Rear door/ramp hydraulic power unit manifold and module removed (WP 0695)

References

TM 9-2355-106-10

WARNING



Never touch any part of a hydraulic assembly before it is known that the system is depressurized. The rear door actuating system operates under high pressure. Pressurized hydraulic fluid can penetrate skin and body tissue. Contact with pressurized hydraulic fluid requires prompt medical attention, even if an injury is not evident. Failure to comply may result in serious injury, amputation, or death to personnel.

Hydraulic fluid is flammable and harmful to skin and eyes. Wear work gloves and eye protection when handling fluids. Do not perform maintenance while smoking or near flame or sparks. If fluid contacts skin, wash affected area immediately. In case of eye contact, flush with water for 15 minutes and seek medical care immediately. Dispose of hydraulic fluid in accordance with standard operating procedures. Failure to comply may result in serious injury to personnel.

Use extreme caution when testing or working on or around electrical circuits. Always assume that electrical circuits are live. Electrical shock can occur upon contact with voltage high enough to cause current flow through muscles or nerves. On Direct Current (DC) systems, generally 1 milliamp of current can be felt, 5 milliamps can cause severe pain, 15 milliamps can cause loss of muscle control, and 70 milliamps can be fatal. Wear protective clothing; ensure skin, clothing, and surrounding areas are dry; do not wear jewelry; and touch only the insulated, nonmetallic parts of electrical components and testing equipment. To prevent electrical arcing, avoid shorting electrical test probes and jumper wires. Electrical arcing can cause bright flashes of light, capable of causing temporary blindness. If electrical injury occurs, immediately shut off power supply and seek medical assistance. Failure to comply may result in serious injury or death to personnel.

REAR DOOR/RAMP HYDRAULIC PUMP REMOVAL AND INSTALLATION (PULL-TYPE OPERATION) - (CONTINUED)

REMOVAL

NOTE

Label all wires prior to removal to ensure proper installation.

1. Remove four retaining nuts, lockwashers, and wires from solenoid studs (Figure 1, Item 1, 6, 7, and 8). Discard lockwashers.

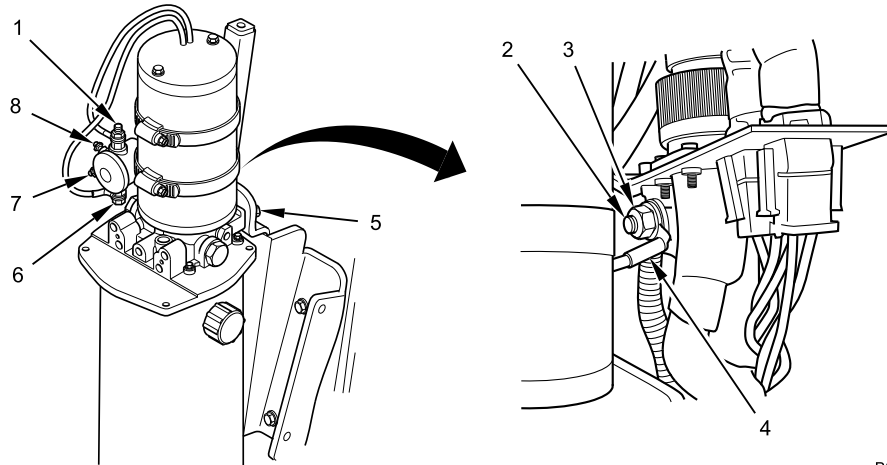

B232403600

Figure 1. Disconnecting Hydraulic Pump Solenoid.

2. Remove ground wire flange nut (Figure 1, Item 3) from ground stud (Figure 1, Item 2).
3. Remove ground wire (Figure 1, Item 4) from ground stud (Figure 1, Item 2).
4. Remove two hydraulic pump assembly retaining bolts (Figure 1, Item 5). One bolt hidden.
5. Remove hydraulic pump assembly.

END OF TASK

INSTALLATION

WARNING



Corrosion preventive compound is toxic. Use only in well-ventilated area. Do not get in eyes; wear chemical safety goggles and full-face shield when using. Avoid contact with skin and wear rubber or plastic, solvent-resistant gloves. In case of contact, remove contaminated clothing and immediately wash area with soap and water. If compound contacts eyes, flush eyes with large amounts of water for at least 15 minutes and get immediate medical attention. If swallowed, do not induce vomiting; contact a physician immediately. Failure to comply may result in serious injury or death to personnel.

REAR DOOR/RAMP HYDRAULIC PUMP REMOVAL AND INSTALLATION (PULL-TYPE OPERATION) - (CONTINUED)

1. Apply corrosion preventive compound to two hydraulic pump assembly retaining bolts (Figure 2, Item 5).

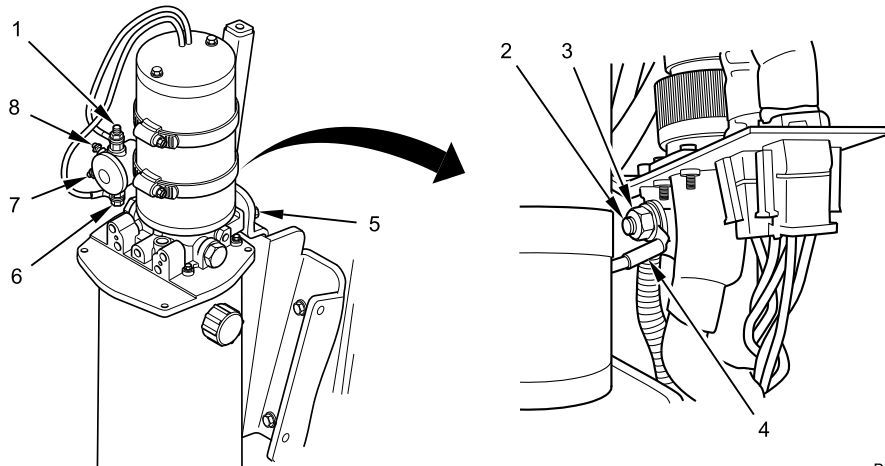

B232403600

Figure 2. Connecting Hydraulic Pump Solenoid.

2. Position hydraulic pump assembly in mounting bracket.
3. Install two hydraulic pump assembly retaining bolts (Figure 2, Item 5). Tighten securely.
4. Install ground wire (Figure 2, Item 4) on ground stud (Figure 2, Item 2).
5. Install ground wire flange nut (Figure 2, Item 3) on ground stud (Figure 2, Item 2) and tighten securely.
6. Install four wires on solenoid studs (Figure 2, Item 1, 6, 7, and 8) with four retaining nuts and new lockwashers. Tighten securely.

END OF TASK

FOLLOW-ON MAINTENANCE

1. Install rear door/ramp hydraulic power unit manifold and module (WP 0695).
2. Connect batteries (WP 0404).
3. Turn MAIN POWER switch on (TM 9-2355-106-10).
4. Verify rear door/ramp operation (TM 9-2355-106-10).
5. Turn MAIN POWER switch off (TM 9-2355-106-10).
6. Remove wheel chocks (TM 9-2355-106-10).

END OF TASK

END OF WORK PACKAGE

FIELD MAINTENANCE
REAR DOOR/RAMP HYDRAULIC HAND PUMP REMOVAL AND INSTALLATION (PUSH-TYPE OPERATION)

INITIAL SETUP:**Tools and Special Tools**

General Mechanic's Tool Kit (GMTK)
(WP 0795, Item 37)
Pan, drain, 5-gal. capacity (WP 0795, Item 75)

TM 9-2355-106-23P

WP 0786

WP 0782

Materials/Parts

Goggles, industrial (WP 0794, Item 20)
Antiseize compound (WP 0794, Item 6)
Hydraulic fluid (WP 0794, Item 25)
Gloves (WP 0794, Item 18)
Rag (WP 0794, Item 39)

Equipment Condition

Parking brake set (TM 9-2355-106-10)
Transmission set in NEUTRAL (N) (TM 9-2355-106-10)
Engine off (TM 9-2355-106-10)
MAIN POWER switch off (TM 9-2355-106-10)
Wheels chocked (TM 9-2355-106-10)
Rear door/ramp hydraulic pump cover removed (WP 0690)

References

TM 9-2355-106-10

WARNING

Hydraulic fluid is flammable and harmful to skin and eyes. Wear work gloves and eye protection when handling fluids. Do not perform maintenance while smoking or near flame or sparks. If fluid contacts skin, wash affected area immediately. In case of eye contact, flush with water for 15 minutes and seek medical care immediately. Dispose of hydraulic fluid in accordance with standard operating procedures. Failure to comply may result in serious injury to personnel.

Never touch any part of a hydraulic assembly before it is known that the system is depressurized. The rear door actuating system operates under high pressure. Pressurized hydraulic fluid can penetrate skin and body tissue. Contact with pressurized hydraulic fluid requires prompt medical attention, even if an injury is not evident. Failure to comply may result in serious injury, amputation, or death to personnel.

Dispose of used parts, rags, containers, and engine fluids in accordance with standard operating procedures. Failure to comply may result in serious injury to personnel.

REAR DOOR/RAMP HYDRAULIC HAND PUMP REMOVAL AND INSTALLATION (PUSH-TYPE OPERATION) - (CONTINUED)

CAUTION

Ensure the rear door hydraulic cylinder pressure hoses are clear of the rear door hand pump pressure gauge. Failure to comply may result in damage to the hand pump pressure gauge.

Do not allow the rear door hand pump to hang unsupported from the rear door pump motor assembly. Failure to comply may damage rear door hand pump, union, or rear door pump motor assembly.

REMOVAL

1. Place drain pan under hand pump (Figure 1, Item 5).

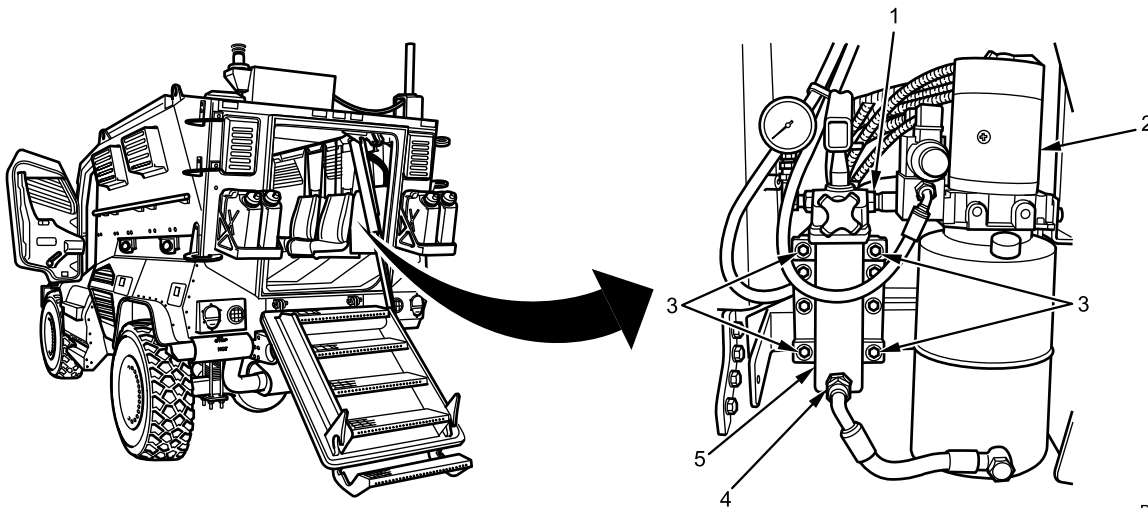

B231806010

Figure 1. Rear Door/Ramp Hand Pump.

2. Disconnect lower hydraulic hose (Figure 1, Item 4) from hand pump (Figure 1, Item 5).
3. Remove four hand pump mounting bolts (Figure 1, Item 3).
4. Disconnect union (Figure 1, Item 1) between hand pump (Figure 1, Item 5) and pump motor assembly (Figure 1, Item 2).
5. Remove hand pump (Figure 1, Item 5) from vehicle.

END OF TASK

REAR DOOR/RAMP HYDRAULIC HAND PUMP REMOVAL AND INSTALLATION (PUSH-TYPE OPERATION) - (CONTINUED)

INSTALLATION

WARNING



Antiseize compound can cause skin, eye, and respiratory irritation. Inhalation can cause difficulty breathing, dizziness, headache, and nausea. Wear eye protection and use only with adequate ventilation. Do not use near heat, sparks, or open flame. Wash hands and eyes after using compound. In case of skin contact, wash affected area with soap and water, and seek medical attention if irritation persists. If compound contacts eyes, flush eyes with water for at least 15 minutes, and obtain medical attention if irritation persists. In case of accidental ingestion, do not induce vomiting. Slowly drink 1-2 glasses of water or milk, and seek medical attention. Store compound in a closed container away from heat. Dispose of it in accordance with standard operating procedures. Failure to comply may result in injury to personnel.

1. Align hand pump (Figure 2, Item 7) to pump motor assembly (Figure 2, Item 3) and connect union (Figure 2, Item 2). Tighten union until hand pump mounting holes line up with holes on mounting surface.

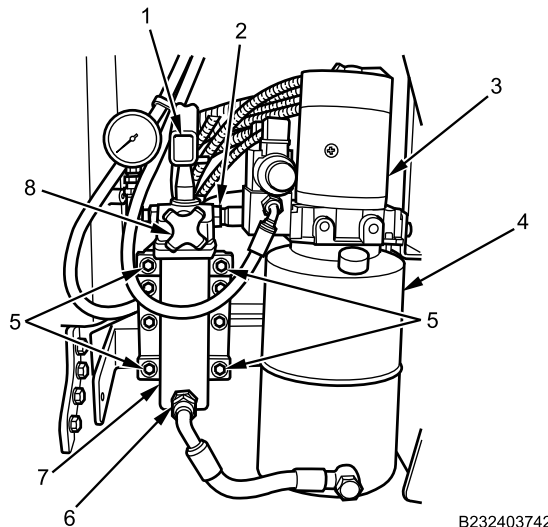

Figure 2. Rear Door/Ramp Hand Pump.

2. Apply antiseize compound to mounting bolts (Figure 2, Item 5).
3. Install hand pump (Figure 2, Item 7) to hull with four bolts (Figure 2, Item 5).
4. Tighten union (Figure 2, Item 2) securely.
5. Install lower hydraulic hose (Figure 2, Item 6) on hand pump (Figure 2, Item 7) and tighten securely.
6. Fill rear door/ramp hydraulic fluid reservoir (Figure 2, Item 4).
7. Purge hydraulic system after filling by turning BLACK knob (Figure 2, Item 8) clockwise until tight.
8. Pump hand pump handle (Figure 2, Item 1) until resistance is firm.
9. Slowly turn BLACK knob (Figure 2, Item 8) counterclockwise until air has escaped from bleeder vent behind BLACK knob. Repeat as necessary.
10. Remove drain pan.

REAR DOOR/RAMP HYDRAULIC HAND PUMP REMOVAL AND INSTALLATION (PUSH-TYPE OPERATION) - (CONTINUED)

11. Clean up all fluid spills with rag.
12. Turn MAIN POWER switch on (TM 9-2355-106-10).
13. Verify operation of rear door/ramp hydraulic hand pump (TM 9-2355-106-10).

WARNING

Check for hydraulic leak location visually from at least an arm's length away and not within the path of the leak. If leak is suspected in a blind area, use scrap pieces of material such as cardboard or wood to check for location. Never use hand or other body parts. Failure to comply may result in serious injury, amputation, or death to personnel.

14. Check hoses and connections for leaks.
15. Turn MAIN POWER switch off (TM 9-2355-106-10).

END OF TASK**FOLLOW-ON MAINTENANCE**

1. Install rear door/ramp hydraulic pump cover (WP 0690).
2. Remove wheel chocks (TM 9-2355-106-10).

END OF TASK**END OF WORK PACKAGE**

FIELD MAINTENANCE

REAR DOOR/RAMP HYDRAULIC POWER UNIT MANIFOLD AND MODULE REMOVAL AND INSTALLATION
(PULL-TYPE OPERATION)

INITIAL SETUP:

Tools and Special Tools

General Mechanic's Tool Kit (GMTK)
(WP 0795, Item 37)
Pan, drain, 5-gal. capacity (WP 0795, Item 75)

TM 9-2355-106-23P
WP 0782

Equipment Condition

Parking brake set (TM 9-2355-106-10)
Transmission set in NEUTRAL (N) (TM 9-2355-106-10)
Engine off (TM 9-2355-106-10)
MAIN POWER switch off (TM 9-2355-106-10)
Wheels chocked (TM 9-2355-106-10)
Rear door/ramp hydraulic pump cover removed (WP 0691)
Rear door/ramp hydraulic hoses removed (WP 0701)

Materials/Parts

Goggles, industrial (WP 0794, Item 20)
Hydraulic fluid (WP 0794, Item 25)
O-ring - (3) (WP 0796, Item 100)
O-ring - (2) (WP 0796, Item 8)
Grease (WP 0794, Item 22)
Gloves (WP 0794, Item 18)
Rag (WP 0794, Item 39)

References

TM 9-2355-106-10

WARNING



Never touch any part of a hydraulic assembly before it is known that the system is depressurized. The rear door actuating system operates under high pressure. Pressurized hydraulic fluid can penetrate skin and body tissue. Contact with pressurized hydraulic fluid requires prompt medical attention, even if an injury is not evident. Failure to comply may result in serious injury, amputation, or death to personnel.

Hydraulic fluid is flammable and harmful to skin and eyes. Wear work gloves and eye protection when handling fluids. Do not perform maintenance while smoking or near flame or sparks. If fluid contacts skin, wash affected area immediately. In case of eye contact, flush with water for 15 minutes and seek medical care immediately. Dispose of hydraulic fluid in accordance with standard operating procedures. Failure to comply may result in serious injury to personnel.

Use extreme caution when testing or working on or around electrical circuits. Always assume that electrical circuits are live. Electrical shock can occur upon contact with voltage high enough to cause current flow through muscles or nerves. On Direct Current (DC) systems, generally 1 milliamp of current can be felt, 5 milliamps can cause severe pain, 15 milliamps can cause loss of muscle control, and 70 milliamps can be fatal. Wear protective clothing; ensure skin, clothing, and surrounding areas are dry; do not wear jewelry; and touch only the insulated, nonmetallic parts of electrical components and testing equipment. To prevent electrical arcing, avoid shorting electrical test probes and jumper wires. Electrical arcing can cause bright flashes of light, capable of causing temporary blindness. If electrical injury occurs, immediately shut off power supply and seek medical assistance. Failure to comply may result in serious injury or death to personnel.

REAR DOOR/RAMP HYDRAULIC POWER UNIT MANIFOLD AND MODULE REMOVAL AND INSTALLATION (PULL-TYPE OPERATION) - (CONTINUED)

REMOVAL

1. Disconnect electrical harness connectors (Figure 1, Item 1 and 3) from manual directional valve (Figure 1, Item 2).

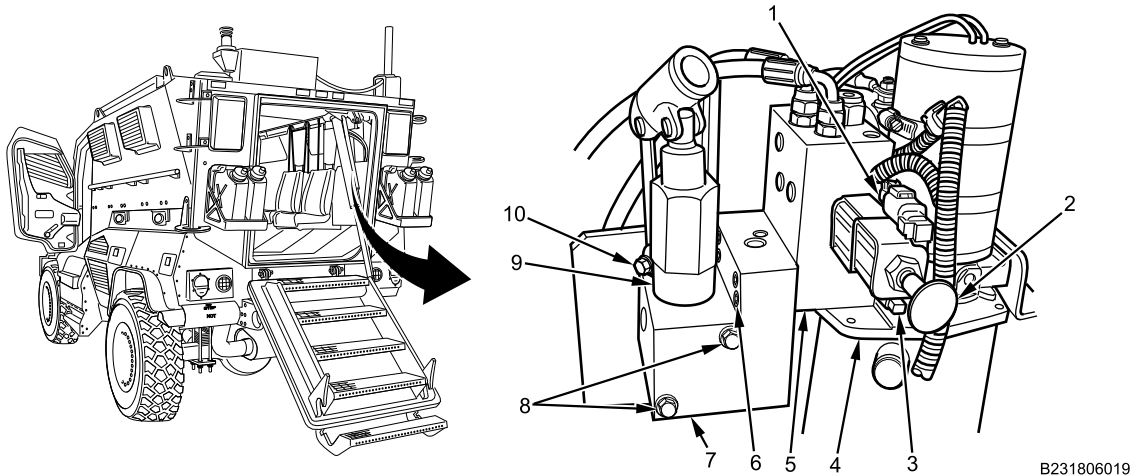

Figure 1. Hydraulic Power Unit Manifold and Module Removal.

2. Place drain pan under hydraulic power unit manifold (Figure 1, Item 7) and hydraulic power unit module (Figure 1, Item 5).
3. Remove retaining nut and bolt (Figure 1, Item 10) from hand pump collar (Figure 1, Item 9). Remove collar from manifold (Figure 1, Item 7).

CAUTION

Hydraulic manifold and module are secured with same four bolts. Hold both parts during bolt removal to prevent them from separating and falling. Failure to comply may result in damage to equipment.

4. Remove six manifold retaining bolts (Figure 1, Item 6 and 8).
5. Remove manifold (Figure 1, Item 7) and module (Figure 1, Item 5) from hydraulic pump assembly (Figure 1, Item 4).
6. Remove and discard O-rings from module.
7. Remove drain pan.
8. Clean up dirt, fluids, and contaminants with rag.

END OF TASK

INSTALLATION

NOTE

Ensure mounting surfaces of manifold and module are clean and free of debris for proper sealing.

1. Coat five new O-rings in module (Figure 2, Item 5) with hydraulic fluid.

REAR DOOR/RAMP HYDRAULIC POWER UNIT MANIFOLD AND MODULE REMOVAL AND INSTALLATION (PULL-TYPE OPERATION) - (CONTINUED)

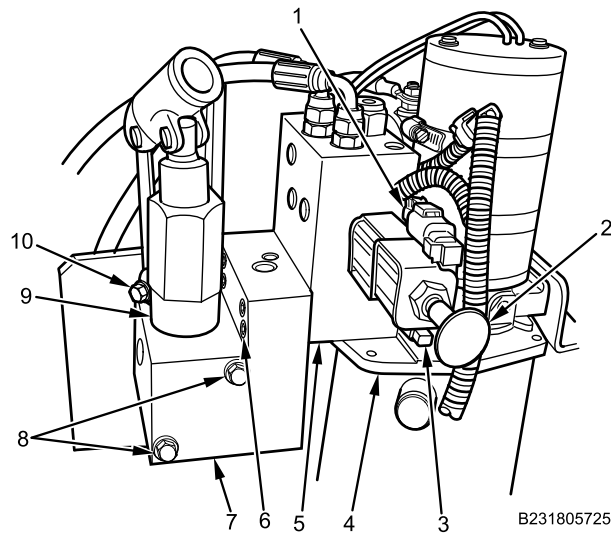

Figure 2. Hydraulic Power Unit Manifold and Module Installation.

2. Install manifold (Figure 2, Item 7) and module (Figure 2, Item 5) on hydraulic pump assembly (Figure 2, Item 4) with six bolts (Figure 2, Item 6 and 8). Tighten securely.
3. Position hand pump collar (Figure 2, Item 9) on manifold (Figure 2, Item 7). Install retaining nut and bolt (Figure 2, Item 10) and tighten securely.

WARNING



Dielectric grease is harmful to skin and eyes. If grease contacts eyes, rinse thoroughly and contact physician if irritation persists. If skin is contacted, wash thoroughly with soap and water. Failure to comply may result in serious injury to personnel.

4. Apply dielectric grease to electrical harness connectors (Figure 2, Item 1 and 3) and connect.

END OF TASK

FOLLOW-ON MAINTENANCE

1. Install rear door/ramp hydraulic hoses (WP 0701).
2. Install rear door/ramp hydraulic pump cover (WP 0691).
3. Remove wheel chocks (TM 9-2355-106-10).

END OF TASK

END OF WORK PACKAGE

FIELD MAINTENANCE**REAR DOOR/RAMP HYDRAULIC CYLINDER REMOVAL AND INSTALLATION (PUSH-TYPE OPERATION)**

INITIAL SETUP:**Tools and Special Tools**

General Mechanic's Tool Kit (GMTK)
(WP 0795, Item 37)
Pan, drain, 5-gal. capacity (WP 0795, Item 75)
Jackstand, 10-ton, 19-28.5-inches (WP 0795, Item 62)

Materials/Parts

Goggles, industrial (WP 0794, Item 20)
Hydraulic fluid (WP 0794, Item 25)
Gloves (WP 0794, Item 18)
Rag (WP 0794, Item 39)
Pin, cotter (WP 0796, Item 123)

Personnel Required

Maintainer - (2)

References

TM 9-2355-106-10
TM 9-2355-106-23P
WP 0786
WP 0782

Equipment Condition

Parking brake set (TM 9-2355-106-10)
Transmission set in NEUTRAL (N) (TM 9-2355-106-10)
Engine off (TM 9-2355-106-10)
Rear Door/Ramp lowered (TM 9-2355-106-10)
MAIN POWER switch off (TM 9-2355-106-10)
Wheels chocked (TM 9-2355-106-10)
Rear door/ramp hydraulic pump cover removed (WP 0690)

REAR DOOR/RAMP HYDRAULIC CYLINDER REMOVAL AND INSTALLATION (PUSH-TYPE OPERATION) - (CONTINUED)**WARNING**

Never touch any part of a hydraulic assembly before it is known that the system is depressurized. The rear door actuating system operates under high pressure. Pressurized hydraulic fluid can penetrate skin and body tissue. Contact with pressurized hydraulic fluid requires prompt medical attention, even if an injury is not evident. Failure to comply may result in serious injury, amputation, or death to personnel.

Ensure no one is behind vehicle when lowering rear door/ramp. Use extreme caution when using emergency rear door/ramp release, to ensure no one is struck by door as it falls open. Sound horn before lowering door/ramp. Keep arms and legs clear of rear door/ramp when closing. Do not operate rear door/ramp when vehicle is in motion. Failure to comply may result in serious injury or death to personnel.

Rear cabin door/ramp is heavy. Make sure door/ramp is secured so it will not move. Failure to comply may result in serious personal injury or death to personnel.

Before lifting vehicle off ground, make sure it is parked on level surface. Set parking brake and chock wheels. Use hydraulic jack to lift vehicle. Jackstands and hydraulic jack must be used on a stable surface capable of supporting the combined weight of the vehicle being lifted and the lifting equipment. Do not use jack alone to support vehicle. Never work under or near a vehicle supported only by jack or lifting device. Use rated jackstands under frame rails to properly support vehicle. Do not support vehicle under front and rear axles. Use additional jackstands as necessary to support vehicle components during removal and installation procedures. Failure to comply may result in damage to equipment and serious injury or death to personnel.

Hydraulic fluid is flammable and harmful to skin and eyes. Wear work gloves and eye protection when handling fluids. Do not perform maintenance while smoking or near flame or sparks. If fluid contacts skin, wash affected area immediately. In case of eye contact, flush with water for 15 minutes and seek medical care immediately. Dispose of hydraulic fluid in accordance with standard operating procedures. Failure to comply may result in serious injury to personnel.

REAR DOOR/RAMP HYDRAULIC CYLINDER REMOVAL AND INSTALLATION (PUSH-TYPE OPERATION) - (CONTINUED)

Dispose of used parts, rags, containers, and engine fluids in accordance with standard operating procedures. Failure to comply may result in serious injury to personnel.

REMOVAL

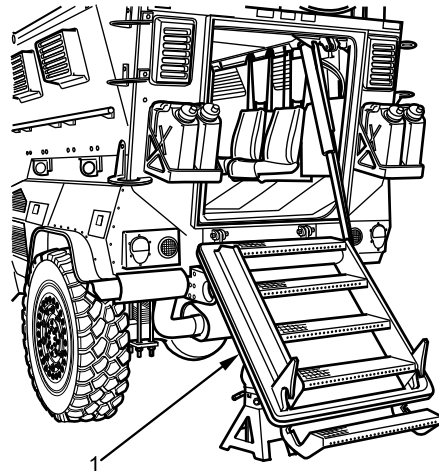

B231802532

Figure 1. Rear Door/Ramp Lowered and Supported with Jackstand.

1. With assistant, position rated jackstand under rear door/ramp (Figure 1, Item 1) for safety and support.

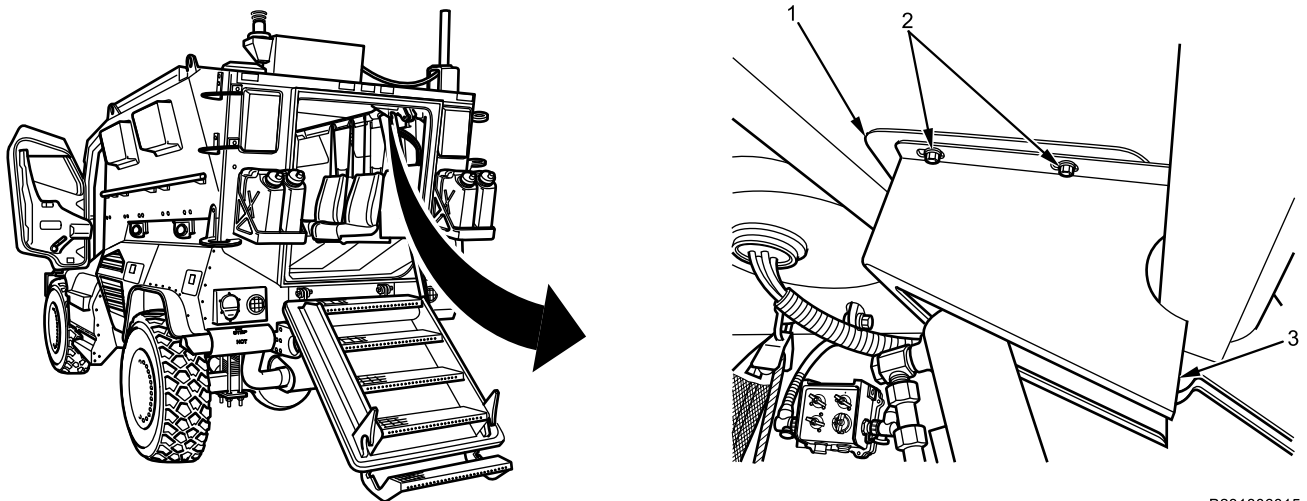

B231806015

Figure 2. Right Side Upper Shroud Cover.

2. Remove four mounting bolts (Figure 2, Item 2) securing right side door lock assembly shroud cover (Figure 2, Item 3) to roof-mounted bracket (Figure 2, Item 1).
3. Remove right side door lock assembly shroud cover (Figure 2, Item 3) from vehicle. Set mounting bolts aside.

REAR DOOR/RAMP HYDRAULIC CYLINDER REMOVAL AND INSTALLATION (PUSH-TYPE OPERATION) - (CONTINUED)

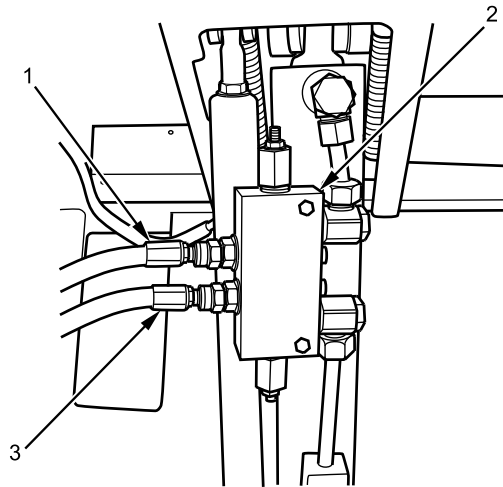

B231803694

Figure 3. Hydraulic Transfer Block Hose Connection.

4. Place drain pan under two hydraulic hose lines (Figure 3, Item 1 and 3) connected to hydraulic transfer block (Figure 3, Item 2).
5. Remove two hydraulic hose lines (Figure 3, Item 1 and 3) from transfer block (Figure 3, Item 2). Drain excess hydraulic fluid into drain pan.

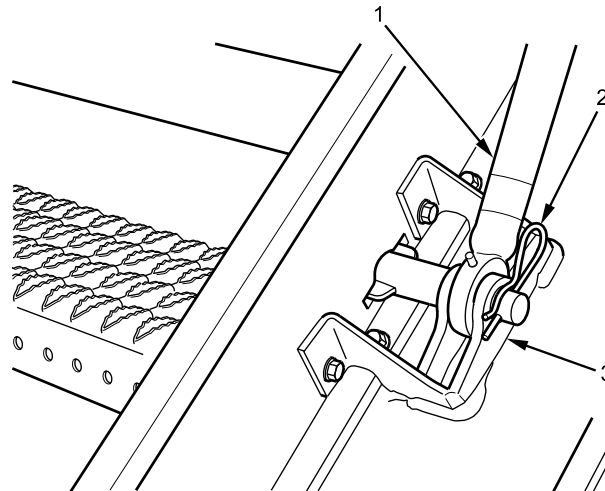

B231802024

Figure 4. Hydraulic Cylinder Locking Safety Pin.

6. Remove locking safety pin (Figure 4, Item 2) connecting rear door/ramp hydraulic cylinder (Figure 4, Item 1) to lower ramp bracket (Figure 4, Item 3).

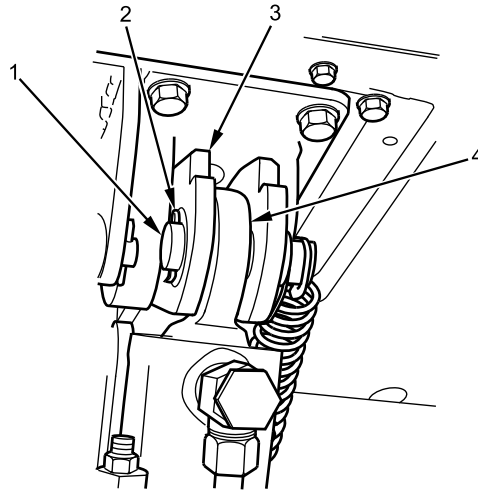
REAR DOOR/RAMP HYDRAULIC CYLINDER REMOVAL AND INSTALLATION (PUSH-TYPE OPERATION) - (CONTINUED)

B231802538

Figure 5. Hydraulic Cylinder Upper Lockpin Shaft and Cotter Pin.

7. Remove cotter pin (Figure 5, Item 2) retaining upper lockpin shaft (Figure 5, Item 1) to upper door lock bracket (Figure 5, Item 3). Discard cotter pin.
8. Remove rear door/ramp hydraulic cylinder top end flange (Figure 5, Item 4) from upper door lock bracket (Figure 5, Item 3) by removing upper lockpin shaft (Figure 5, Item 1).
9. With assistant, remove rear door/ramp hydraulic cylinder (Figure 5, Item 1) from lower ramp bracket (Figure 5, Item 3).
10. Remove drain pan and clean up fluid spills, loose dirt, and contaminants with rag.

END OF TASK

REAR DOOR/RAMP HYDRAULIC CYLINDER REMOVAL AND INSTALLATION (PUSH-TYPE OPERATION) - (CONTINUED)

INSTALLATION

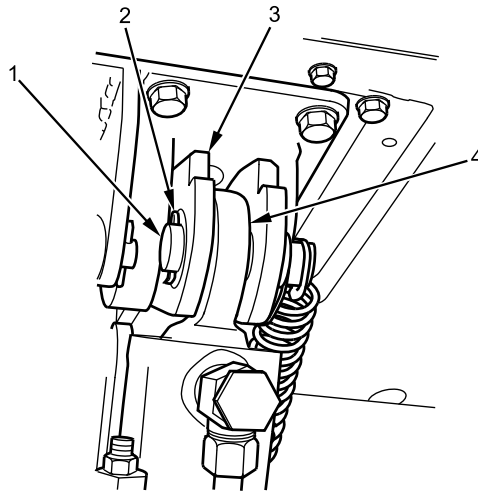

B231802538

Figure 6. Hydraulic Cylinder Upper Lockpin Shaft and Cotter Pin.

1. Install top end flange (Figure 6, Item 4) of rear door/ramp hydraulic cylinder on upper door lock bracket (Figure 6, Item 3) by inserting upper lockpin shaft (Figure 6, Item 1) through upper door lock bracket and hydraulic cylinder top end flange.
2. Carefully align upper lockpin shaft (Figure 6, Item 1) to outer edge of upper door lock bracket (Figure 6, Item 3).
3. Secure upper lockpin shaft (Figure 6, Item 1) on door lock bracket (Figure 6, Item 3) and hydraulic cylinder top end flange (Figure 6, Item 4) with new cotter pin (Figure 6, Item 2).

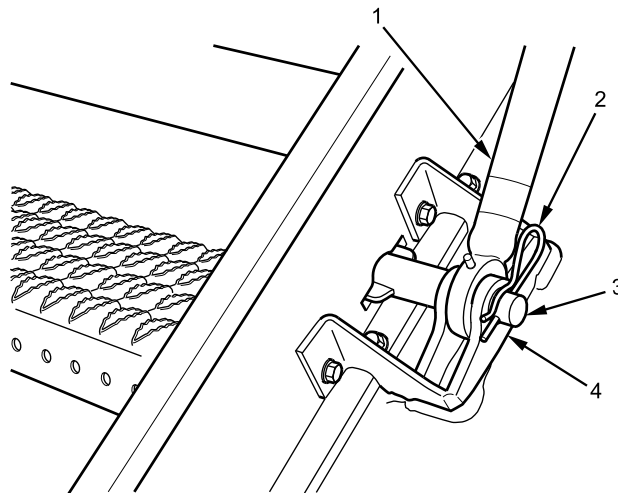

B231803697

Figure 7. Hydraulic Cylinder Locking Safety Pin.

4. With assistant, insert rear door/ramp hydraulic cylinder (Figure 7, Item 1) on ramp-mounted shaft (Figure 7, Item 3) in center of lower ramp bracket (Figure 7, Item 4).
5. Install locking safety pin (Figure 7, Item 2) on ramp-mounted shaft (Figure 7, Item 3), securing rear door/ramp hydraulic cylinder (Figure 7, Item 1) to lower ramp bracket (Figure 7, Item 4).

REAR DOOR/RAMP HYDRAULIC CYLINDER REMOVAL AND INSTALLATION (PUSH-TYPE OPERATION) - (CONTINUED)

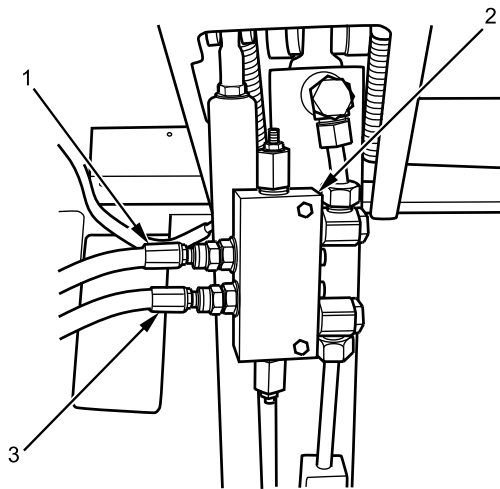

B231803694

Figure 8. Hydraulic Transfer Block Hose Connection.

6. Install two hydraulic hose lines (Figure 8, Item 1 and 3) to transfer block (Figure 8, Item 2) mounted on hydraulic cylinder. Tighten hose line fittings securely.

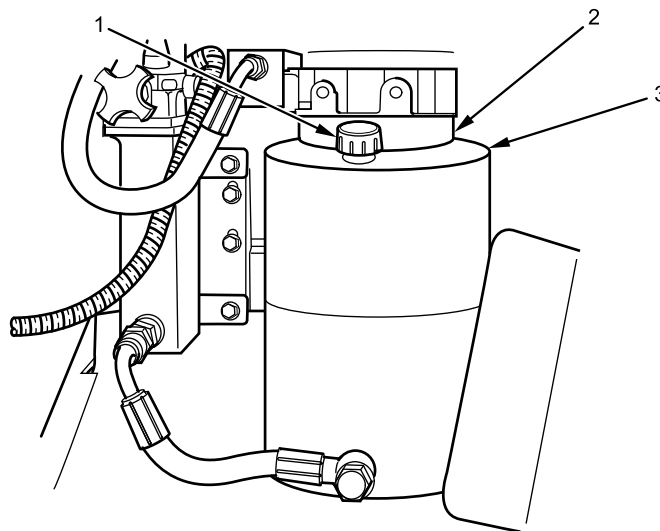

B231800783

Figure 9. Hydraulic Reservoir Filled with Hydraulic Fluid.

7. Remove twist-off cap and dipstick (Figure 9, Item 1) from hydraulic reservoir (Figure 9, Item 3) located under hydraulic pump unit (Figure 9, Item 2).
8. Refill hydraulic reservoir (Figure 9, Item 3) with hydraulic fluid. Install twist-off cap and dipstick (Figure 9, Item 1) on reservoir and tighten securely.

REAR DOOR/RAMP HYDRAULIC CYLINDER REMOVAL AND INSTALLATION (PUSH-TYPE OPERATION) - (CONTINUED)

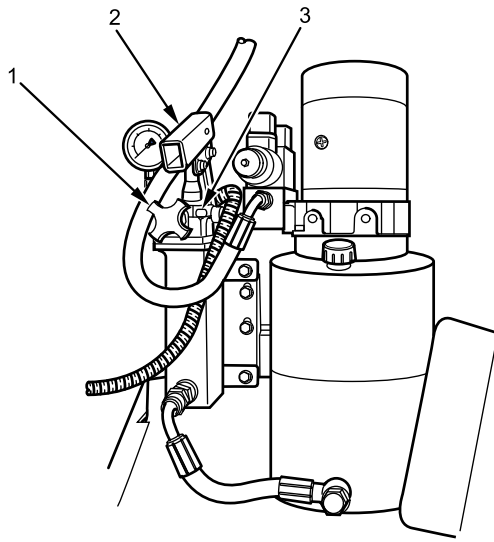

B231800784

Figure 10. Restoration of Hydraulic Pressure in Hydraulic Pump Assembly.

9. Turn BLACK knob (Figure 10, Item 1) located under manual jack (Figure 10, Item 2) clockwise until tight.
10. Insert jack handle in manual jack (Figure 10, Item 2) and pump jack handle up and down until handle operation becomes stiff.
11. Turn BLACK knob (Figure 10, Item 1) counterclockwise until air begins venting out from air bleeder valve (Figure 10, Item 3) behind BLACK knob. Repeat as necessary until air is depleted from bleeder.

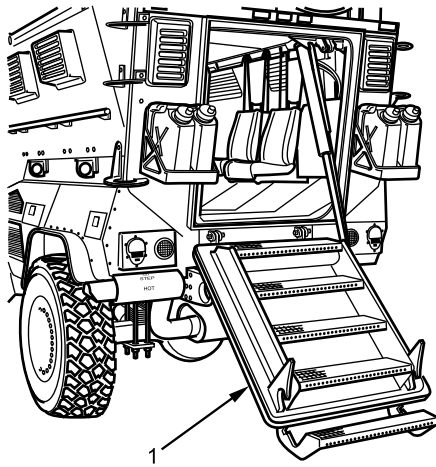

B231801603

Figure 11. Jackstand Removed from Rear Door/Ramp.

REAR DOOR/RAMP HYDRAULIC CYLINDER REMOVAL AND INSTALLATION (PUSH-TYPE OPERATION) - (CONTINUED)

12. With assistant, remove jackstand from support location under rear door/ramp (Figure 11, Item 1).
13. Turn MAIN POWER switch on (TM 9-2355-106-10).

WARNING

Check for hydraulic leak location visually from at least an arm's length away and not within the path of the leak. If leak is suspected in a blind area, use scrap pieces of material such as cardboard or wood to check for location. Never use hand or other body parts. Failure to comply may result in serious injury, amputation, or death to personnel.

14. Open and close rear door/ramp (Figure 11, Item 1) to verify proper operation and check for leaks. Leave rear door/ramp in the open position (TM 9-2355-106-10).
15. Turn MAIN POWER switch off (TM 9-2355-106-10).

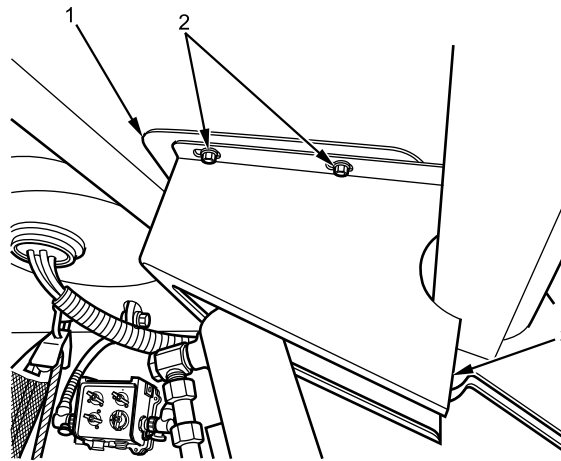

B231801697

Figure 12. Right Side Upper Shroud Cover.

16. Install right side door lock assembly shroud cover (Figure 12, Item 3) on roof-mounted bracket (Figure 12, Item 1) with four mounting bolts (Figure 12, Item 2).

END OF TASK

FOLLOW-ON MAINTENANCE

1. Turn MAIN POWER switch on (TM 9-2355-106-10).
2. Close rear door/ramp (TM 9-2355-106-10).
3. Turn MAIN POWER switch off (TM 9-2355-106-10).
4. Install rear door/ramp hydraulic pump cover (WP 0690).
5. Remove wheel chocks (TM 9-2355-106-10).

END OF TASK

END OF WORK PACKAGE

FIELD MAINTENANCE**REAR DOOR/RAMP HYDRAULIC CYLINDER REMOVAL AND INSTALLATION (PULL-TYPE OPERATION)**

INITIAL SETUP:**Tools and Special Tools**

General Mechanic's Tool Kit (GMTK)
(WP 0795, Item 37)
Jackstand (10-ton) (WP 0795, Item 62)
Pan, drain, 5-gal. capacity (WP 0795, Item 75)

Materials/Parts

Gloves (WP 0794, Item 18)
Goggles, industrial (WP 0794, Item 20)
Hydraulic fluid (WP 0794, Item 25)
Rag (WP 0794, Item 39)
Pin, cotter (WP 0796, Item 123)

Personnel Required

Maintainer - (2)

References

TM 9-2355-106-10
TM 9-2355-106-23P
WP 0782

Equipment Condition

Parking brake set (TM 9-2355-106-10)
Transmission set in NEUTRAL (N) (TM
9-2355-106-10)
Engine off (TM 9-2355-106-10)
MAIN POWER switch off (TM 9-2355-106-10)
Wheels chocked (TM 9-2355-106-10)
Rear door/ramp hydraulic pump cover removed
(WP 0691)

REAR DOOR/RAMP HYDRAULIC CYLINDER REMOVAL AND INSTALLATION (PULL-TYPE OPERATION) - (CONTINUED)**REMOVAL****WARNING**

Never touch any part of a hydraulic assembly before it is known that the system is depressurized. The rear door actuating system operates under high pressure. Pressurized hydraulic fluid can penetrate skin and body tissue. Contact with pressurized hydraulic fluid requires prompt medical attention, even if an injury is not evident. Failure to comply may result in serious injury, amputation, or death to personnel.

Ensure no one is behind vehicle when lowering rear door/ramp. Use extreme caution when using emergency rear door/ramp release, to ensure no one is struck by door as it falls open. Keep arms and legs clear of rear door/ramp when closing. Do not operate rear door/ramp when vehicle is in motion. Failure to comply may result in serious injury or death to personnel.

Use caution when using jackstands to support vehicle components during removal and installation procedures. Failure to comply may result in damage to equipment and serious injury or death to personnel.

Hydraulic fluid is flammable and harmful to skin and eyes. Wear work gloves and eye protection when handling fluids. Do not perform maintenance while smoking or near flame or sparks. If fluid contacts skin, wash affected area immediately. In case of eye contact, flush with water for 15 minutes and seek medical care immediately. Dispose of hydraulic fluid in accordance with standard operating procedures. Failure to comply may result in serious injury to personnel.

Dispose of used parts, rags, containers, and engine fluids in accordance with standard operating procedures. Failure to comply may result in serious injury to personnel.

REAR DOOR/RAMP HYDRAULIC CYLINDER REMOVAL AND INSTALLATION (PULL-TYPE OPERATION) - (CONTINUED)

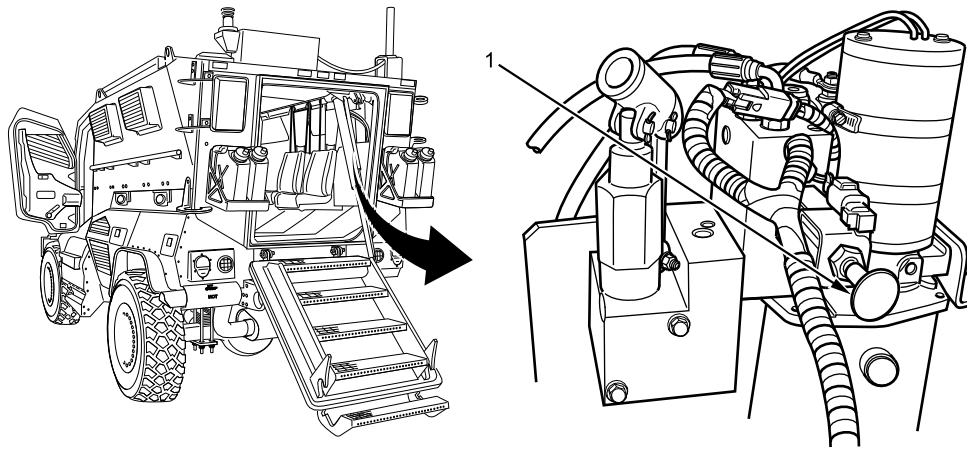

B231806020

Figure 1. Manual Override Directional Valve.

NOTE

Manual override directional valve knob has three positions:

- Middle is neutral.
- Pushed all the way in and turned clockwise is locked door/ramp up.
- Pulled all the way out and turned counterclockwise is locked door/ramp down.

The directional valve knob can be moved in and out freely from neutral to operate door/ramp up and down without locking in position.

Hydraulic pressure is relieved in steps 1 through 4.

1. If manual override directional valve is not already in neutral position, rotate valve knob (Figure 1, Item 1) as follows:
 - a. To place manual override directional valve in neutral from locked door/ramp up position, turn knob (Figure 1, Item 1) counterclockwise until it stops and springs outward slightly.
 - b. To place manual override directional valve in neutral from locked door/ramp down position, turn knob (Figure 1, Item 1) clockwise until it stops and springs inward slightly.
2. Push and pull manual override directional valve (Figure 1, Item 1) until rear door/ramp will not move up or down.

REAR DOOR/RAMP HYDRAULIC CYLINDER REMOVAL AND INSTALLATION (PULL-TYPE OPERATION) - (CONTINUED)

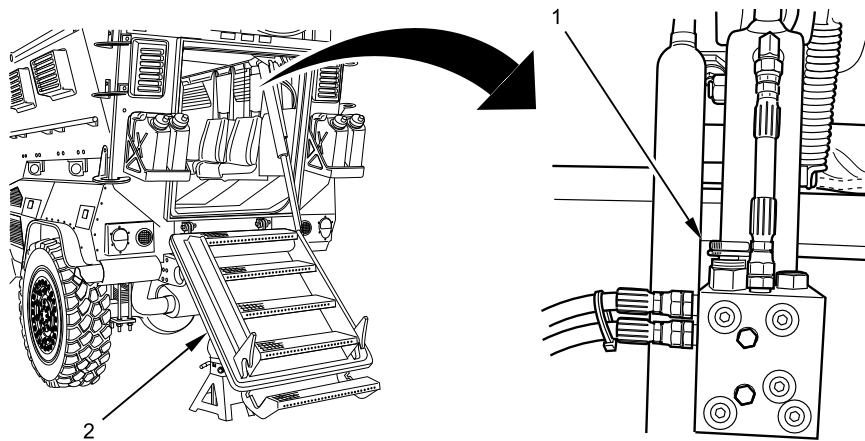

B231805699

Figure 2. Rear Door/Ramp Lowered and Supported with Jackstand.

3. With assistant, lower rear door/ramp (Figure 2, Item 2) assembly gently onto rated jackstand from current position by slowly turning the emergency lowering valve (Figure 2, Item 1) counterclockwise.
4. Close emergency lowering valve (Figure 2, Item 1) by turning clockwise.

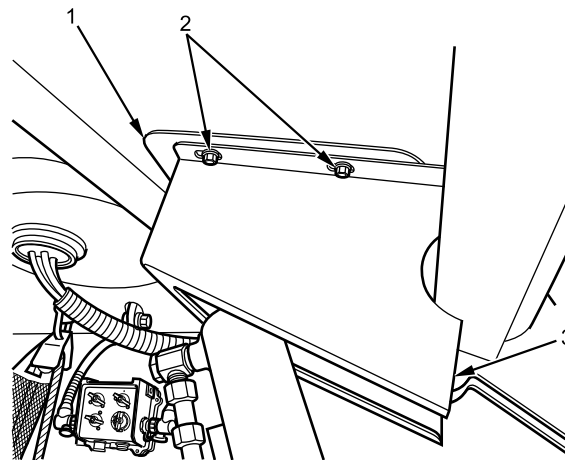

B231801697

Figure 3. Right Side Upper Shroud Cover Removal.

5. Remove four mounting bolts (Figure 3, Item 2) securing right side door lock assembly shroud cover (Figure 3, Item 3) to roof-mounted bracket (Figure 3, Item 1).
6. Remove right side door lock assembly shroud cover (Figure 3, Item 3) from vehicle.

REAR DOOR/RAMP HYDRAULIC CYLINDER REMOVAL AND INSTALLATION (PULL-TYPE OPERATION) - (CONTINUED)

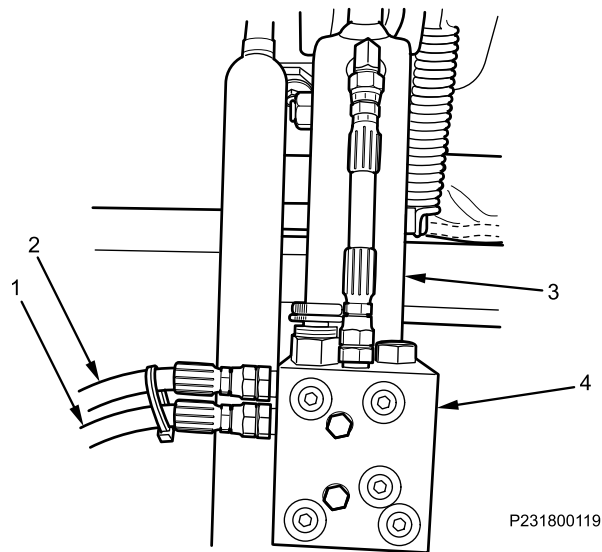

Figure 4. Hydraulic Hose Lines Removal and Hydraulic Fluid Drained.

7. Place drain pan under two hydraulic hose lines (Figure 4, Item 1 and 2) connected to hydraulic transfer block (Figure 4, Item 4) on rear door/ramp hydraulic cylinder (Figure 4, Item 3).
8. Remove two hydraulic hoses (Figure 4, Item 1 and 2) from transfer block (Figure 4, Item 4). Drain excess hydraulic fluid in drain pan.

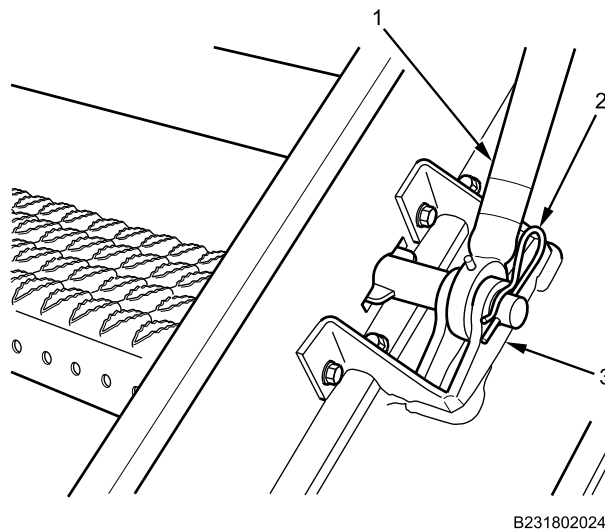
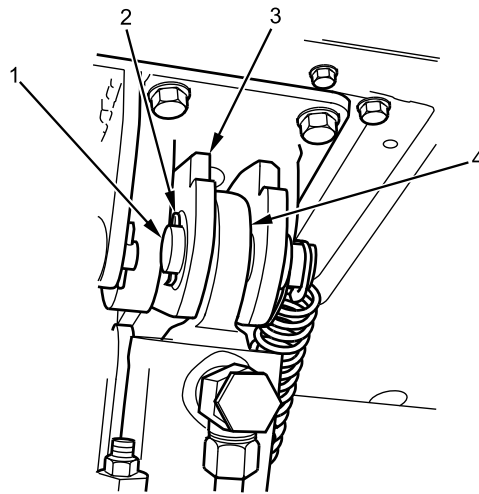

Figure 5. Locking Safety Pin Removed from Hydraulic Cylinder.

9. With assistant, remove locking safety pin (Figure 5, Item 2) connecting rear door/ramp hydraulic cylinder (Figure 5, Item 1) to lower ramp bracket (Figure 5, Item 3).

REAR DOOR/RAMP HYDRAULIC CYLINDER REMOVAL AND INSTALLATION (PULL-TYPE OPERATION) - (CONTINUED)



B231802538

Figure 6. Cotter Pin and Hydraulic Cylinder Removal.

10. Remove and discard cotter pin (Figure 6, Item 2) retaining upper lockpin shaft (Figure 6, Item 1) to upper door lock bracket (Figure 6, Item 3).
11. With assistant, remove upper lockpin shaft (Figure 6, Item 1) from upper door lock bracket (Figure 6, Item 3).
12. Remove rear door/ramp hydraulic cylinder top end flange (Figure 6, Item 4) from upper door lock bracket (Figure 6, Item 3).
13. With assistant, remove hydraulic cylinder (Figure 5, Item 1) from lower ramp bracket (Figure 5, Item 3).
14. Clean up hydraulic fluid spills with rag.
15. Remove drain pan.

END OF TASK

INSTALLATION

1. With assistant, install top end flange (Figure 7, Item 4) of rear door/ramp hydraulic cylinder on upper door lock bracket (Figure 7, Item 3) by inserting upper lockpin shaft (Figure 7, Item 1) through bracket and top end flange.

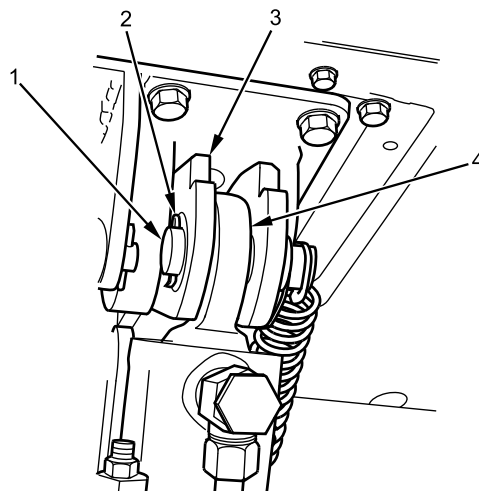

B231802538

Figure 7. Rear Door/Ramp Hydraulic Cylinder Installed in Upper Door Lock Bracket.

REAR DOOR/RAMP HYDRAULIC CYLINDER REMOVAL AND INSTALLATION (PULL-TYPE OPERATION) - (CONTINUED)

2. Install new cotter pin (Figure 7, Item 2) in upper lockpin shaft (Figure 7, Item 1).
3. With assistant, position rear door/ramp hydraulic cylinder (Figure 8, Item 1) on ramp-mounted shaft in center of lower ramp bracket (Figure 8, Item 3).

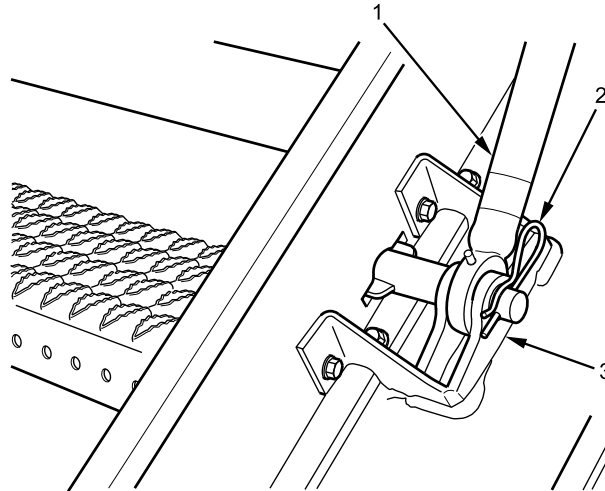

B231802024

Figure 8. Hydraulic Cylinder Installed on Rear/Door Ramp.

4. With assistant, install locking safety pin (Figure 8, Item 2) on ramp-mounted shaft, securing rear door/ramp hydraulic cylinder (Figure 8, Item 1) to lower ramp bracket (Figure 8, Item 3).

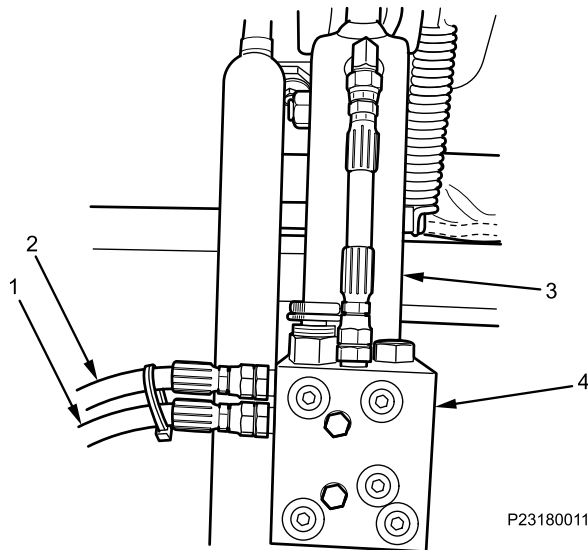

P231800119

Figure 9. Hydraulic Hose Lines Connected to Transfer Block.

5. Install two hydraulic hoses (Figure 9, Item 1 and 2) on transfer block (Figure 9, Item 4) mounted on hydraulic cylinder (Figure 9, Item 3). Tighten hose fittings securely.
6. Turn MAIN DISCONNECT switch on (TM 9-2355-106-10).

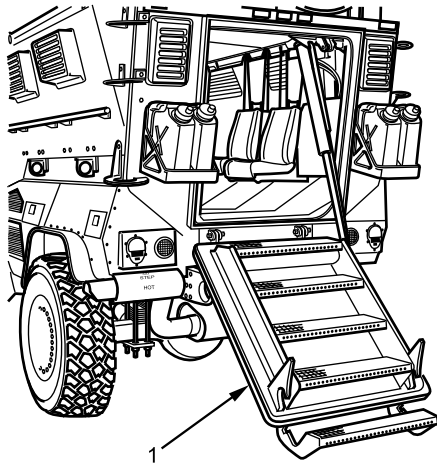
REAR DOOR/RAMP HYDRAULIC CYLINDER REMOVAL AND INSTALLATION (PULL-TYPE OPERATION) - (CONTINUED)

B231801603

Figure 10. Jackstand Removed from Rear Door/Ramp.

7. With assistant, raise rear door/ramp (Figure 10, Item 1) to closed position and remove jackstand.

WARNING

Check for hydraulic leak location visually from at least an arm's length away and not within the path of the leak. If leak is suspected in a blind area, use scrap pieces of material such as cardboard or wood to check for location. Never use hand or other body parts. Failure to comply may result in serious injury, amputation, or death to personnel.

8. Open and close rear door/ramp (Figure 10, Item 1) to check for leaks and proper operation. Leave rear door/ramp in the open position (TM 9-2355-106-10).
9. Turn MAIN POWER switch off (TM 9-2355-106-10).
10. Check rear door/ramp hydraulic fluid level (WP 0699).

REAR DOOR/RAMP HYDRAULIC CYLINDER REMOVAL AND INSTALLATION (PULL-TYPE OPERATION) - (CONTINUED)

11. Install right side door lock assembly shroud cover (Figure 11, Item 3) on roof-mounted bracket (Figure 11, Item 1) with four mounting bolts (Figure 11, Item 2).

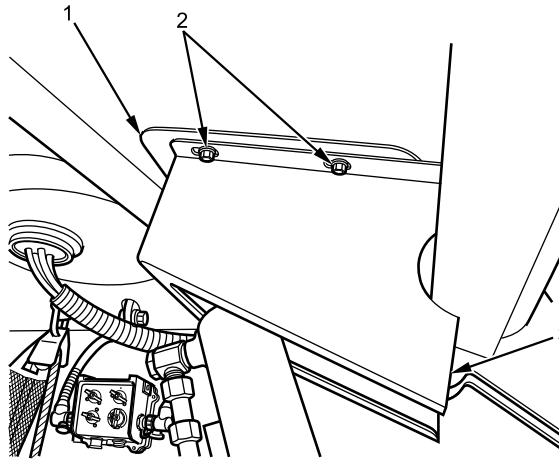

B231801697

Figure 11. Right Side Upper Shroud Cover Installed.

12. Turn MAIN POWER switch on (TM 9-2355-106-10).
13. Raise rear door/ramp to closed position (TM 9-2355-106-10).
14. Turn MAIN POWER switch off (TM 9-2355-106-10).

END OF TASK**FOLLOW-ON MAINTENANCE**

1. Install rear door/ramp hydraulic pump cover (WP 0691).
2. Remove wheel chocks (TM 9-2355-106-10).

END OF TASK**END OF WORK PACKAGE**

FIELD MAINTENANCE

REAR DOOR/RAMP GAS SPRING REMOVAL AND INSTALLATION

INITIAL SETUP:

Tools and Special Tools

General Mechanic's Tool Kit (GMTK)
(WP 0795, Item 37)
Wrench, torque, click, ratcheting, 15-75 lb-ft, 3/8-inch
drive (WP 0795, Item 145)

TM 9-2355-106-23P

WP 0782

Equipment Condition

Parking brake set (TM 9-2355-106-10)
Transmission set in NEUTRAL (N) (TM
9-2355-106-10)
Engine off (TM 9-2355-106-10)
MAIN POWER switch off (TM 9-2355-106-10)
Wheels chocked (TM 9-2355-106-10)
Rear door/ramp closed (TM 9-2355-106-10)

Materials/Parts

Bolt, 7/16 in.-14 x 2.5 in., full-thread - (2)
(WP 0796, Item 7)
Nut, 7/16 in.- 14 - (2) (WP 0796, Item 6)
Pin, cotter - (2) (WP 0796, Item 127)
Lockwasher - (5) (WP 0796, Item 25)

References

TM 9-2355-106-10

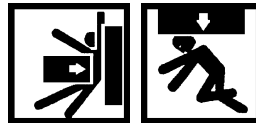
WARNING

Ensure no one is behind vehicle when lowering rear door/ramp. Use extreme caution when using emergency rear door/ramp release, to ensure no one is struck by door as it falls open. Sound horn before lowering door/ramp. Keep arms and legs clear of rear door/ramp when closing. Do not operate rear door/ramp when vehicle is in motion. Failure to comply may result in serious injury or death to personnel.

Never touch any part of a hydraulic assembly before it is known that the system is depressurized. The rear door actuating system operates under high pressure. Pressurized hydraulic fluid can penetrate skin and body tissue. Contact with pressurized hydraulic fluid requires prompt medical attention, even if an injury is not evident. Failure to comply may result in serious injury, amputation, or death to personnel.

REAR DOOR/RAMP GAS SPRING REMOVAL AND INSTALLATION - (CONTINUED)

REMOVAL

NOTE

Door must remain in closed position until instructed to open.

1. Remove four bolts (Figure 1, Item 2) securing right side door lock assembly shroud cover (Figure 1, Item 3) to roof-mounted bracket (Figure 1, Item 1).

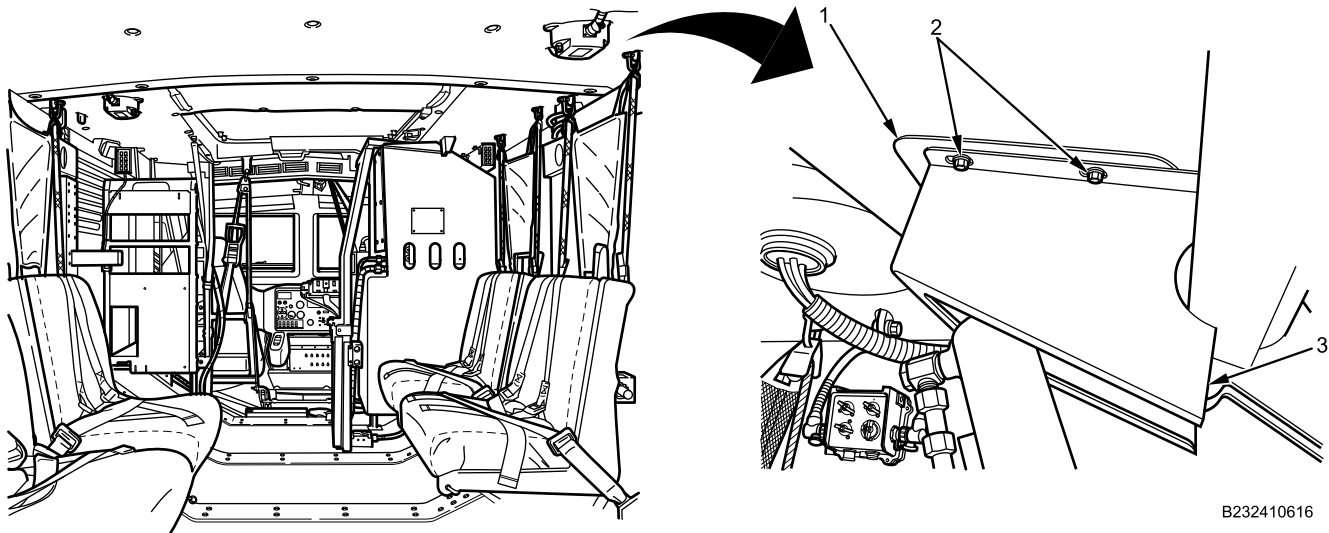

B232410616

Figure 1. Right Side Upper Shroud Cover.

2. Remove right side door lock assembly shroud cover (Figure 1, Item 3).

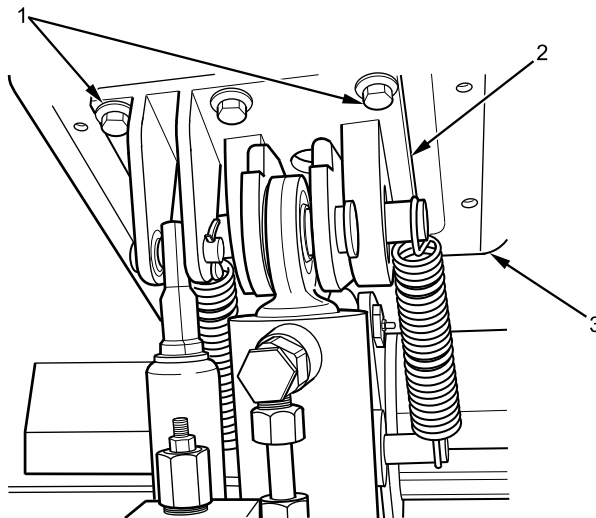

B235002854

Figure 2. Upper Door/Ramp Lock Bracket Front Bolts.

3. Remove two front outer bolts (Figure 2, Item 1) and lockwashers securing upper door lock bracket (Figure 2, Item 2) to roof-mounted bracket (Figure 2, Item 3). Discard lockwashers.

REAR DOOR/RAMP GAS SPRING REMOVAL AND INSTALLATION - (CONTINUED)

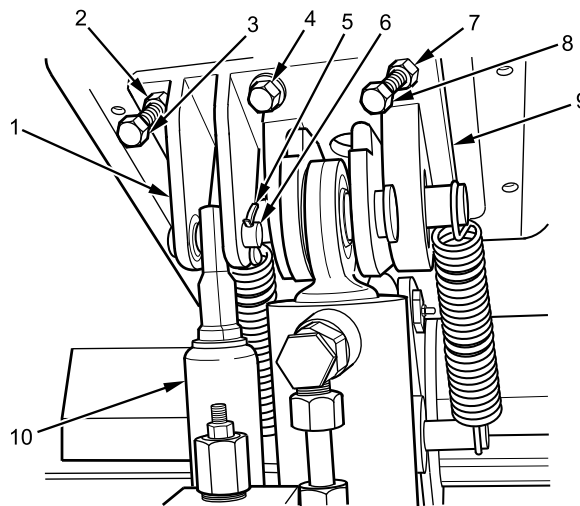

B231805824

Figure 3. Lowering Upper Lock Bracket and Removing Gas Spring.

4. Replace two front outer bolts with 7/16 in.-14 x 2.5-in. full-thread bolts (Figure 3, Item 3 and 8) and nuts (Figure 3, Item 2 and 7).
 - a. Install nuts (Figure 3, Item 2 and 7) up to head of 7/16 in.-14 x 2.5-in. full-thread bolts (Figure 3, Item 3 and 8).
 - b. Install 7/16 in.-14 x 2.5-in. full-thread bolts (Figure 3, Item 3 and 8) in threaded holes through door lock bracket (Figure 3, Item 9) until bottomed out.
 - c. Tighten nuts (Figure 3, Item 2 and 7) against upper door lock bracket (Figure 3, Item 9).
5. Lower upper door lock bracket (Figure 3, Item 9).
 - a. Remove remaining front bolt (Figure 3, Item 4) and lockwasher securing upper door lock bracket (Figure 3, Item 9). Discard lockwasher.

CAUTION

Loosening rear bolts more than two turns may result in upper door lock bracket separation from vehicle and thread damage.

- b. Loosen two rear bolts (not shown) securing upper door lock bracket (Figure 3, Item 9) not more than two turns.
- c. Gradually loosen both nuts (Figure 3, Item 2 and 7) while preventing bolts (Figure 3, Item 3 and 8) from turning until tension is released from gas spring (Figure 3, Item 10).
6. Remove cotter pin (Figure 3, Item 5) securing lockpin shaft (Figure 3, Item 6) to upper door lock flange (Figure 3, Item 1). Discard cotter pin.
7. Remove lockpin shaft (Figure 3, Item 6) from upper door lock flange (Figure 3, Item 1).
8. Remove upper end of gas spring (Figure 3, Item 10) from upper door lock bracket flange (Figure 3, Item 1).

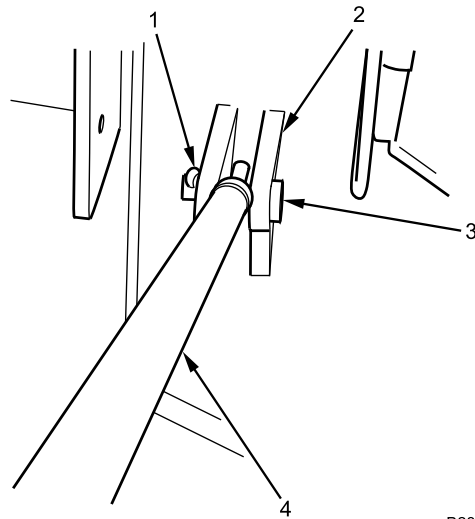
REAR DOOR/RAMP GAS SPRING REMOVAL AND INSTALLATION - (CONTINUED)

B231802624

Figure 4. Rear Door/Ramp Lower Gas Spring Bracket.

9. Remove cotter pin (Figure 4, Item 1) from lockpin shaft (Figure 4, Item 3). Discard cotter pin.
10. Remove lockpin shaft (Figure 4, Item 3) from lower ramp bracket (Figure 4, Item 2).
11. Remove gas spring (Figure 4, Item 4) from lower ramp bracket (Figure 4, Item 2).

END OF TASK

REAR DOOR/RAMP GAS SPRING REMOVAL AND INSTALLATION - (CONTINUED)

INSTALLATION

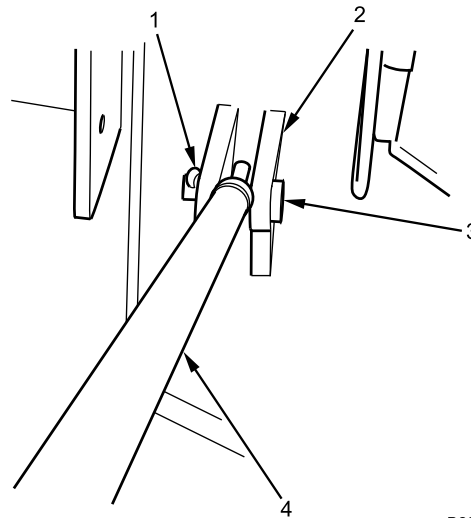

B231802624

Figure 5. Rear Door/Ramp Lower Gas Spring Bracket.

1. Install rear door/ramp gas spring (Figure 5, Item 4) in lower ramp bracket (Figure 5, Item 2) with lockpin shaft (Figure 5, Item 3).
2. Install new cotter pin (Figure 5, Item 1) on lockpin shaft (Figure 5, Item 3).

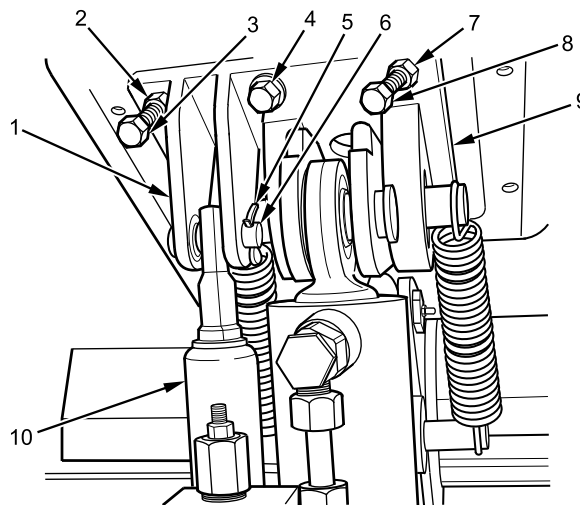

B231805824

Figure 6. Installing Gas Spring and Securing Upper Lock Bracket.

3. Install upper end of rear door/ramp gas spring (Figure 6, Item 10) on upper door lock bracket flange (Figure 6, Item 1) with lockpin shaft (Figure 6, Item 6).
4. Install new cotter pin (Figure 6, Item 5) in lockpin shaft (Figure 6, Item 6).
5. Tighten nuts (Figure 6, Item 2 and 7) alternately while holding bolts (Figure 6, Item 3 and 8) until door lock bracket (Figure 6, Item 9) is secured to ceiling.
6. Install new lockwasher and front center door lock bracket retaining bolt (Figure 6, Item 4).
7. Tighten two rear door/ramp lock bracket retaining bolts (not shown) securely.

REAR DOOR/RAMP GAS SPRING REMOVAL AND INSTALLATION - (CONTINUED)

8. Remove two nuts (Figure 6, Item 2 and 7) and bolts (Figure 6, Item 3 and 8).

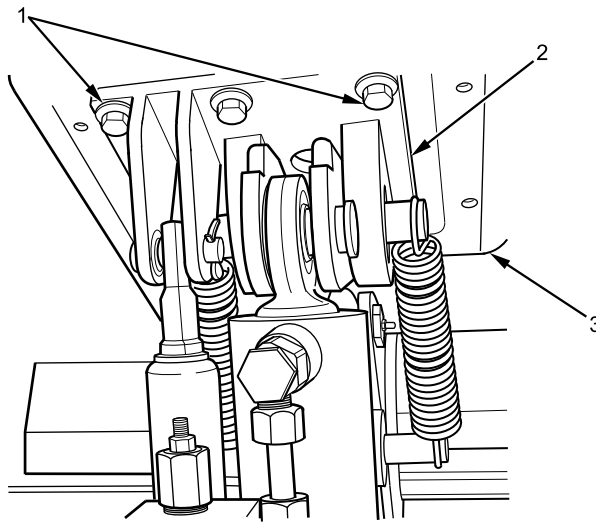

B235002854

Figure 7. Upper Door Lock Bracket Bolts.

9. Install door lock bracket (Figure 7, Item 2) to roof-mounted bracket (Figure 7, Item 3) with new lockwashers and two front outer retaining bolts (Figure 7, Item 1).

CAUTION

Remove only one rear bolt at a time while the opposing rear bolt remains securely fastened to the bracket. Failure to comply may result in damage to upper lock bracket and fasteners.

10. Remove two rear bolts (not shown) one at a time, replace lockwashers, and reinstall bolts.
11. Torque all five door lock bracket retaining bolts to 30 lb-ft (41 N•m).
12. Turn MAIN POWER switch on (TM 9-2355-106-10).
13. Open and close rear door/ramp to verify proper operation. Leave rear door/ramp in open position (TM 9-2355-106-10).
14. Turn MAIN POWER switch off (TM 9-2355-106-10).

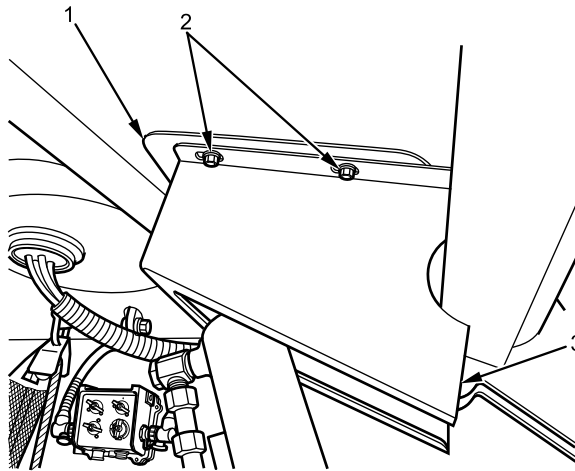
REAR DOOR/RAMP GAS SPRING REMOVAL AND INSTALLATION - (CONTINUED)

B231801697

Figure 8. Right Side Upper Shroud Cover.

15. Install right side door lock assembly shroud cover (Figure 8, Item 3) on roof-mounted bracket (Figure 8, Item 1) with four bolts (Figure 8, Item 2).
16. Turn MAIN POWER switch on (TM 9-2355-106-10).
17. Raise rear door/ramp to closed position (TM 9-2355-106-10).
18. Turn MAIN POWER switch off (TM 9-2355-106-10).

END OF TASK**FOLLOW-ON MAINTENANCE**

1. Remove wheel chocks (TM 9-2355-106-10).

END OF TASK**END OF WORK PACKAGE**

FIELD MAINTENANCE

REAR DOOR/RAMP HYDRAULIC RESERVOIR FLUID FILL PROCEDURE (PULL-TYPE OPERATION)

INITIAL SETUP:

Tools and Special Tools

General Mechanic's Tool Kit (GMTK)
(WP 0795, Item 37)
Funnel, flexible spout, 1 qt. capacity (WP 0795, Item 35)
Gloves, rubber (WP 0795, Item 38)

Materials/Parts

Goggles, industrial (WP 0794, Item 20)
Hydraulic fluid (WP 0794, Item 25)
Rag (WP 0794, Item 39)

References

TM 9-2355-106-10
TM 9-2355-106-23P

WP 0786

WP 0782

Equipment Condition

Parking brake set (TM 9-2355-106-10)
Transmission set in NEUTRAL (N) (TM 9-2355-106-10)
Engine off (TM 9-2355-106-10)
MAIN POWER switch off (TM 9-2355-106-10)
Wheels chocked (TM 9-2355-106-10)
Rear door/ramp in closed position (TM 9-2355-106-10)
Rear door/ramp hydraulic pump cover removed (WP 0691)

WARNING



Never touch any part of a hydraulic assembly before it is known that the system is depressurized. The rear door actuating system operates under high pressure. Pressurized hydraulic fluid can penetrate skin and body tissue. Contact with pressurized hydraulic fluid requires prompt medical attention, even if an injury is not evident. Failure to comply may result in serious injury, amputation, or death to personnel.

Hydraulic fluid is flammable and harmful to skin and eyes. Wear work gloves and eye protection when handling fluids. Do not perform maintenance while smoking or near flame or sparks. If fluid contacts skin, wash affected area immediately. In case of eye contact, flush with water for 15 minutes and seek medical care immediately. Dispose of hydraulic fluid in accordance with standard operating procedures. Failure to comply may result in serious injury to personnel.

Dispose of used parts, rags, containers, and engine fluids in accordance with standard operating procedures. Failure to comply may result in serious injury to personnel.

REAR DOOR/RAMP HYDRAULIC RESERVOIR FLUID FILL PROCEDURE (PULL-TYPE OPERATION) - (CONTINUED)**SERVICE**

1. Remove fill cap (Figure 1, Item 2) from hydraulic reservoir (Figure 1, Item 1).

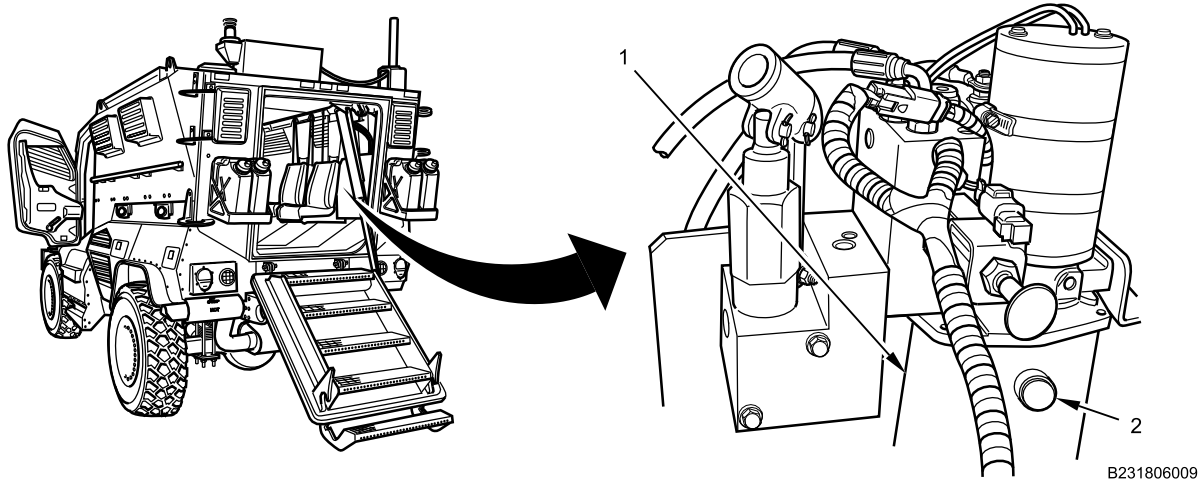

Figure 1. Hydraulic Reservoir Cap Removal.

CAUTION

Hydraulic reservoir must contain a minimum of 1.25 gal. (4.7 L) of hydraulic fluid for safe and proper operation. Failure to comply may result in electric motor failure or damage to equipment.

2. Fill hydraulic reservoir (Figure 2, Item 1) with hydraulic fluid to bottom of fill cap hole (Figure 2, Item 2).

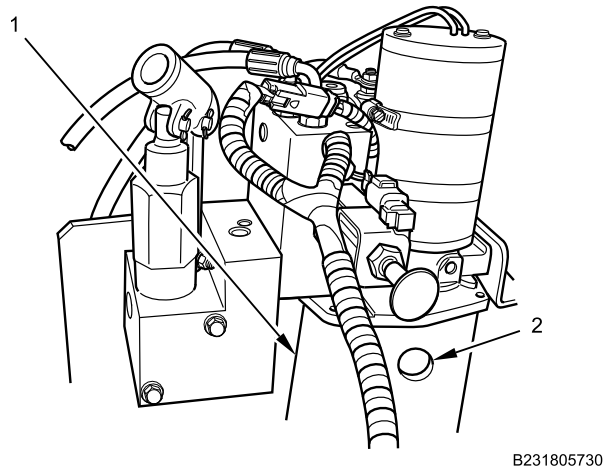
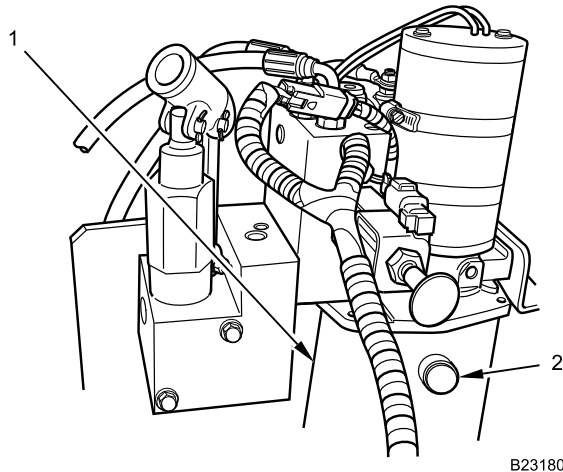

Figure 2. Hydraulic Reservoir Filling.

REAR DOOR/RAMP HYDRAULIC RESERVOIR FLUID FILL PROCEDURE (PULL-TYPE OPERATION) - (CONTINUED)

3. Install fill cap (Figure 3, Item 2) on hydraulic reservoir (Figure 3, Item 1). Tighten and secure.



B231805729

Figure 3. Hydraulic Reservoir Cap Installation.

4. Clean up all fluid spills with rag.
5. Turn MAIN POWER switch on (TM 9-2355-106-10).
6. Verify proper rear door/ramp operation (TM 9-2355-106-10).
7. Turn MAIN POWER switch off (TM 9-2355-106-10).

END OF TASK**FOLLOW-ON MAINTENANCE**

1. Install rear door/ramp hydraulic pump cover (WP 0691).
2. Remove wheel chocks (TM 9-2355-106-10).

END OF TASK**END OF WORK PACKAGE**

FIELD MAINTENANCE
REAR DOOR/RAMP HYDRAULIC HOSES REMOVAL AND INSTALLATION (PUSH-TYPE OPERATION)

INITIAL SETUP:**Tools and Special Tools**

General Mechanic's Tool Kit (GMTK)
(WP 0795, Item 37)
Pan, drain, 5-gal. capacity (WP 0795, Item 75)

TM 9-2355-106-23P

WP 0786

WP 0782

Materials/Parts

Gloves (WP 0794, Item 18)
Goggles, industrial (WP 0794, Item 20)
Hydraulic fluid (WP 0794, Item 25)
Rag (WP 0794, Item 39)

Equipment Condition

Parking brake set (TM 9-2355-106-10)
Transmission set in NEUTRAL (N) (TM
9-2355-106-10)
Engine off (TM 9-2355-106-10)
MAIN POWER switch off (TM 9-2355-106-10)
Wheels chocked (TM 9-2355-106-10)
Rear door/ramp hydraulic pump cover removed
(WP 0690)

References

TM 9-2355-106-10

WARNING

Never touch any part of a hydraulic assembly before it is known that the system is depressurized. The rear door actuating system operates under high pressure. Pressurized hydraulic fluid can penetrate skin and body tissue. Contact with pressurized hydraulic fluid requires prompt medical attention, even if an injury is not evident. Failure to comply may result in serious injury, amputation, or death to personnel.

Hydraulic fluid is flammable and harmful to skin and eyes. Wear work gloves and eye protection when handling fluids. Do not perform maintenance while smoking or near flame or sparks. If fluid contacts skin, wash affected area immediately. In case of eye contact, flush with water for 15 minutes and seek medical care immediately. Dispose of hydraulic fluid in accordance with standard operating procedures. Failure to comply may result in serious injury to personnel.

Dispose of used parts, rags, containers, and engine fluids in accordance with standard operating procedures. Failure to comply may result in serious injury to personnel.

REAR DOOR/RAMP HYDRAULIC HOSES REMOVAL AND INSTALLATION (PUSH-TYPE OPERATION) - (CONTINUED)

REMOVAL

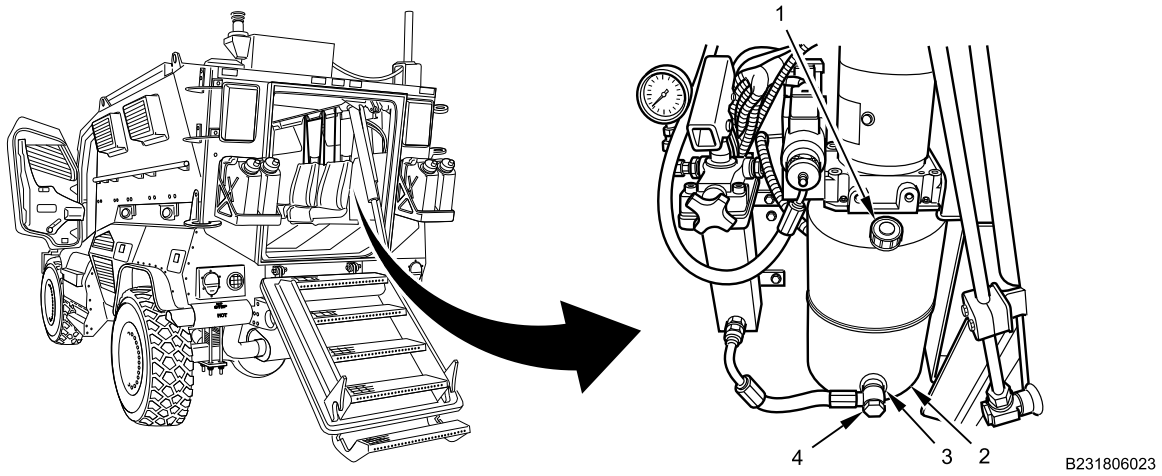

Figure 1. Hydraulic Fluid Drained from Rear Door/Ramp Hydraulic Reservoir.

1. Place drain pan under hydraulic fluid reservoir (Figure 1, Item 2).
2. Remove hydraulic reservoir twist-off cap and dipstick (Figure 1, Item 1) from top of hydraulic fluid reservoir (Figure 1, Item 2).
3. Disconnect lower hose fitting (Figure 1, Item 4) at base of hydraulic fluid reservoir (Figure 1, Item 2).
4. Drain hydraulic fluid from valve opening (Figure 1, Item 3) at base of hydraulic fluid reservoir (Figure 1, Item 2) into drain pan.

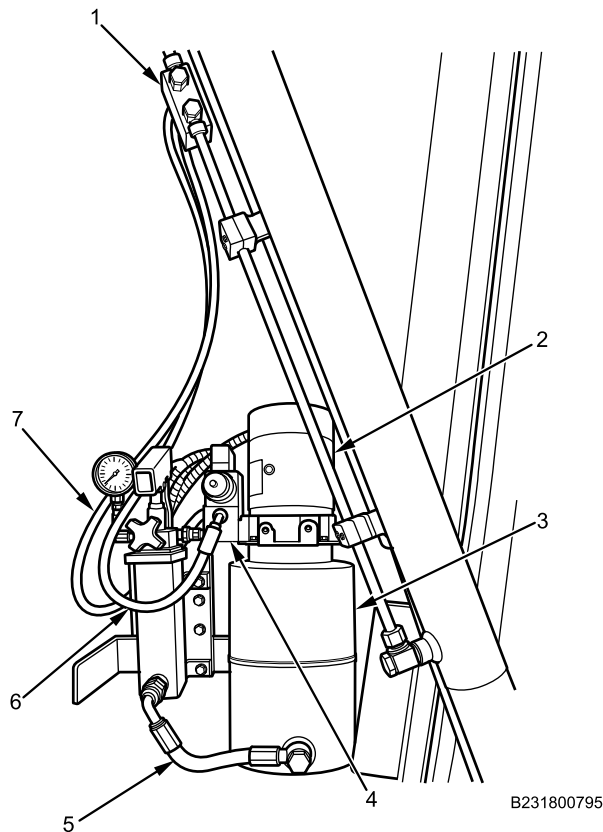

Figure 2. Three Hydraulic Hoses Removed.

REAR DOOR/RAMP HYDRAULIC HOSES REMOVAL AND INSTALLATION (PUSH-TYPE OPERATION) - (CONTINUED)

5. Disconnect two upper hydraulic hoses (Figure 2, Item 6 and 7) from hydraulic transfer block (Figure 2, Item 1).
6. Remove two upper hydraulic hoses (Figure 2, Item 6 and 7) from front and back sides of hydraulic pump upper bracket (Figure 2, Item 4), located behind hydraulic power unit (Figure 2, Item 2).
7. Remove lower hydraulic hose (Figure 2, Item 5) from lower left side bracket fitting.
8. Drain residual hydraulic fluid from three hoses (Figure 2, Item 5, 6, and 7) into drain pan.
9. Install twist-off cap and dipstick at top of hydraulic fluid reservoir (Figure 2, Item 3). Tighten cap and dipstick securely.
10. Clean up dirt, fluids, and contaminants with rag.

END OF TASK

INSTALLATION

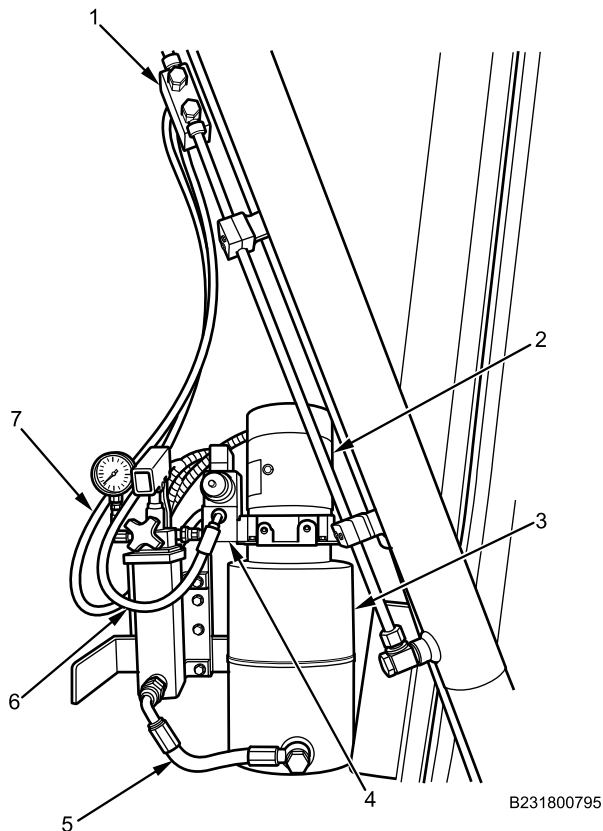
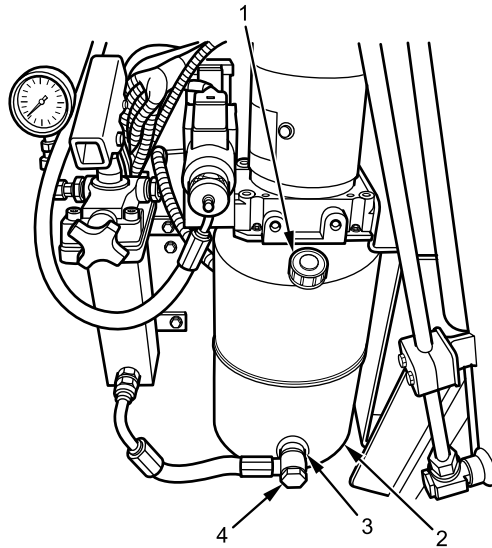

Figure 3. Three Hydraulic Hoses Installed.

1. Install one end of lower hydraulic hose (Figure 3, Item 5) on lower left side bracket fitting. Tighten fitting securely.
2. Install two upper hydraulic hoses (Figure 3, Item 6 and 7) on front and back sides of hydraulic pump upper bracket (Figure 3, Item 4), located behind hydraulic power unit (Figure 3, Item 2) and hydraulic fluid reservoir (Figure 3, Item 3). Tighten all hose connections securely.
3. Install two upper hydraulic hoses (Figure 3, Item 6 and 7) on upper hydraulic transfer block (Figure 3, Item 1). Tighten all hose connections securely.

REAR DOOR/RAMP HYDRAULIC HOSES REMOVAL AND INSTALLATION (PUSH-TYPE OPERATION) - (CONTINUED)

B231800794

Figure 4. Hydraulic Reservoir Refilled with Hydraulic Fluid.

4. Install lower hose fitting (Figure 4, Item 4) on valve opening (Figure 4, Item 3) at base of hydraulic fluid reservoir (Figure 4, Item 2). Tighten fitting securely.
5. Remove twist-off cap and dipstick (Figure 4, Item 1) from top of hydraulic fluid reservoir (Figure 4, Item 2).

CAUTION

Hydraulic reservoir must contain a minimum of 1.25 gal (4.73 L) of hydraulic fluid for safe and proper operation. Failure to comply may result in electric motor failure or damage to equipment.

6. Refill hydraulic fluid reservoir (Figure 4, Item 2) with hydraulic fluid.
7. Install twist-off cap and dipstick (Figure 4, Item 1) at top of hydraulic fluid reservoir (Figure 4, Item 2). Tighten cap securely.

REAR DOOR/RAMP HYDRAULIC HOSES REMOVAL AND INSTALLATION (PUSH-TYPE OPERATION) - (CONTINUED)

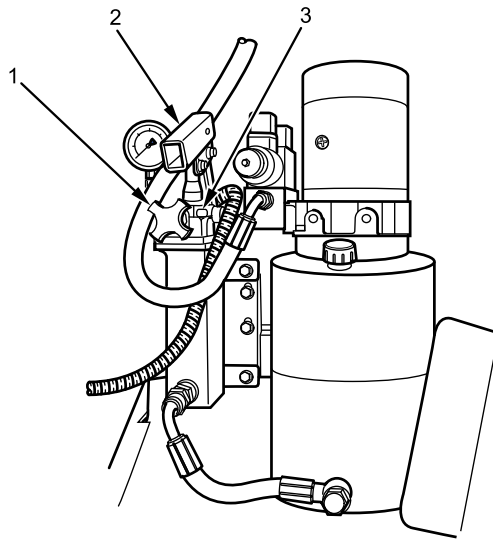

B231800784

Figure 5. Restoration of Hydraulic Pressure in Hydraulic Pump Assembly.

8. Turn BLACK knob (Figure 5, Item 1) located under manual jack (Figure 5, Item 2) clockwise until knob is tight.
9. Insert jack handle in manual jack (Figure 5, Item 2) and pump jack handle up and down until handle operation becomes stiff.
10. Turn BLACK knob (Figure 5, Item 1) counterclockwise until air begins venting out from air bleeder valve (Figure 5, Item 3) behind BLACK knob. Repeat as necessary until air is depleted from bleeder.
11. Remove drain pan from underneath hydraulic reservoir.
12. Clean up all spills, loose debris, and contaminants with rag.
13. Turn MAIN POWER switch on (TM 9-2355-106-10).
14. Verify proper rear door/ramp operation (TM 9-2355-106-10).

WARNING



Check for hydraulic leak location visually from at least an arm's length away and not within the path of the leak. If leak is suspected in a blind area, use scrap pieces of material such as cardboard or wood to check for location. Never use hand or other body parts. Failure to comply may result in serious injury, amputation, or death to personnel.

15. Check hoses and connections for leaks.
16. Turn MAIN POWER switch off (TM 9-2355-106-10).
17. Check hydraulic fluid level and top off as necessary.

END OF TASK

**REAR DOOR/RAMP HYDRAULIC HOSES REMOVAL AND INSTALLATION (PUSH-TYPE OPERATION) -
(CONTINUED)****FOLLOW-ON MAINTENANCE**

1. Install rear door/ramp hydraulic pump cover (WP 0690).
2. Remove wheel chocks (TM 9-2355-106-10).

END OF TASK**END OF WORK PACKAGE**

FIELD MAINTENANCE
REAR DOOR/RAMP HYDRAULIC HOSES REMOVAL AND INSTALLATION (PULL-TYPE OPERATION)

INITIAL SETUP:**Tools and Special Tools**

General Mechanic's Tool Kit (GMTK)
 (WP 0795, Item 37)
 Jackstand, (10-ton) (WP 0795, Item 62)
 Pan, drain, 5-gal. capacity (WP 0795, Item 75)

Materials/Parts

Gloves (WP 0794, Item 18)
 Goggles, industrial (WP 0794, Item 20)
 Hydraulic fluid (WP 0794, Item 25)
 Rag (WP 0794, Item 39)
 Wire tag - (8) (WP 0794, Item 65)
 O-ring - (8) (WP 0796, Item 100)
 Cable, lock strap - (4) (WP 0796, Item 124)

Personnel Required

Maintainer - (2)

References

TM 9-2355-106-10
 TM 9-2355-106-23P
 WP 0782

Equipment Condition

Parking brake set (TM 9-2355-106-10)
 Transmission set in NEUTRAL (N) (TM 9-2355-106-10)
 Engine off (TM 9-2355-106-10)
 MAIN POWER switch off (TM 9-2355-106-10)
 Wheels chocked (TM 9-2355-106-10)
 Rear door/ramp hydraulic pump cover removed
 (WP 0691)

REMOVAL
WARNING

Never touch any part of a hydraulic assembly before it is known that the system is depressurized. The rear door actuating system operates under high pressure. Pressurized hydraulic fluid can penetrate skin and body tissue. Contact with pressurized hydraulic fluid requires prompt medical attention, even if an injury is not evident. Failure to comply may result in serious injury, amputation, or death to personnel.

Ensure no one is behind vehicle when lowering rear door/ramp. Use extreme caution when using emergency rear door/ramp release, to ensure no one is struck by door as it falls open. Keep arms and legs clear of rear door/ramp when closing. Do not operate rear door/ramp when vehicle is in motion. Failure to comply may result in serious injury or death to personnel.

Use caution when using jackstands to support vehicle components during removal and installation procedures. Failure to comply may result in damage to equipment and serious injury or death to personnel.

Hydraulic fluid is flammable and harmful to skin and eyes. Wear work gloves and eye protection when handling fluids. Do not perform maintenance while smoking or near flame or sparks. If fluid contacts skin, wash affected area immediately. In case of eye contact, flush with water for 15 minutes and seek medical care immediately. Dispose of hydraulic fluid in accordance with standard operating procedures. Failure to comply may result in serious injury to personnel.

Dispose of used parts, rags, containers, and engine fluids in accordance with standard operating procedures. Failure to comply may result in serious injury personnel.

REAR DOOR/RAMP HYDRAULIC HOSES REMOVAL AND INSTALLATION (PULL-TYPE OPERATION) - (CONTINUED)

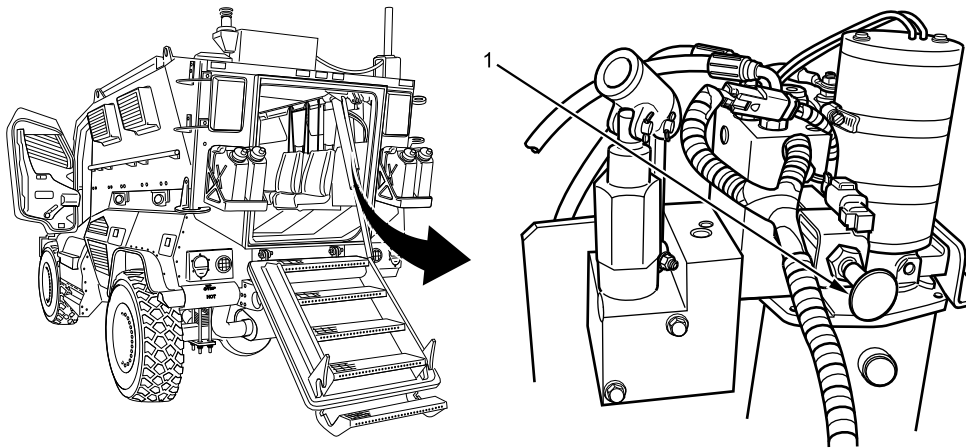

B231806020

Figure 1. Manual Override Directional Valve.

NOTE

Manual override directional valve knob has three positions:

- Middle is neutral.
- Pushed all the way in and turned clockwise is locked door/ramp up.
- Pulled all the way out and turned counterclockwise is locked door/ramp down.

The directional valve knob can be moved in and out freely from neutral to operate door/ramp up and down without locking in position.

Hydraulic pressure is relieved in steps 1 through 4.

1. If manual override directional valve is not already in neutral position, rotate valve knob (Figure 1, Item 1) as follows:
 - a. To place manual override directional valve in neutral from locked door/ramp up position, turn knob (Figure 1, Item 1) counterclockwise until it stops and springs outward slightly.
 - b. To place manual override directional valve in neutral from locked door/ramp down position, turn knob (Figure 1, Item 1) clockwise until it stops and springs inward slightly.
2. Push and pull manual override directional valve (Figure 1, Item 1) until rear door/ramp will not move up or down.

REAR DOOR/RAMP HYDRAULIC HOSES REMOVAL AND INSTALLATION (PULL-TYPE OPERATION) - (CONTINUED)

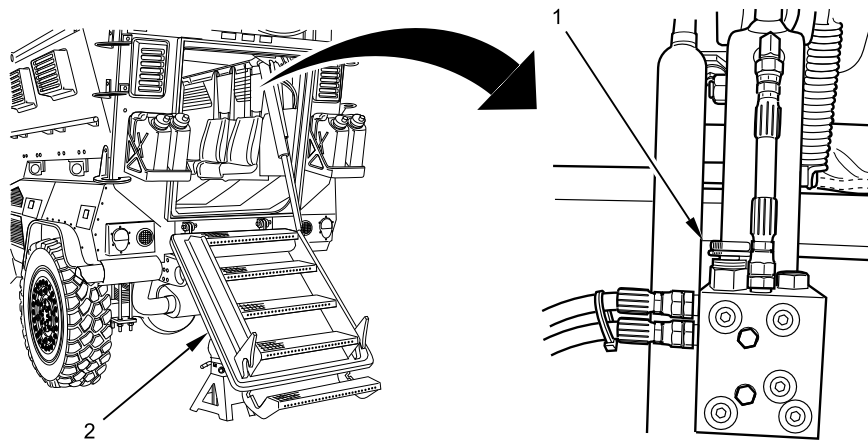

B231805699

Figure 2. Rear Door/Ramp Lowered and Supported with Jackstand.

3. With assistant, lower rear door/ramp (Figure 2, Item 2) assembly gently onto rated jackstand from current position by slowly turning the emergency lowering valve (Figure 2, Item 1) counterclockwise.
4. Close emergency lowering valve (Figure 2, Item 1) by turning clockwise.

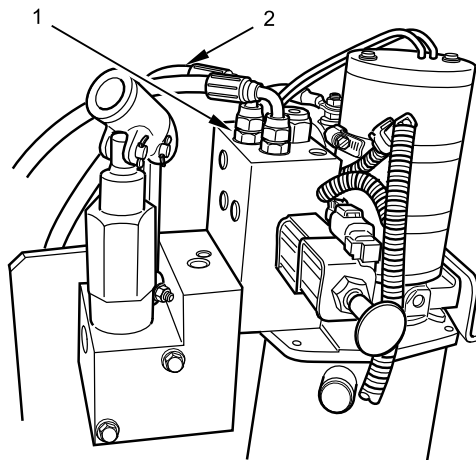

B231805731

Figure 3. Hydraulic Power Module-to-Hydraulic Cylinder Hose Removal.

NOTE

Label all hoses with wire tags prior to removal to ensure proper installation.

5. Place drain pan under hydraulic hose (Figure 3, Item 2).
6. Disconnect hydraulic hose (Figure 3, Item 2) from outer hydraulic power module fitting (Figure 3, Item 1). Remove and discard O-ring.

REAR DOOR/RAMP HYDRAULIC HOSES REMOVAL AND INSTALLATION (PULL-TYPE OPERATION) - (CONTINUED)

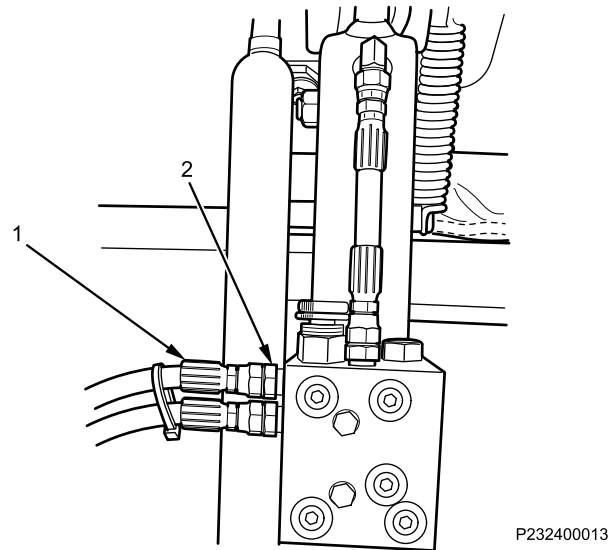

Figure 4. Hydraulic Power Module-to-Hydraulic Cylinder Hose Removal.

NOTE

Note location of cable lock straps prior to removal to aid in installation.

7. Remove cable lock straps as needed.
8. Place drain pan under hydraulic hose (Figure 4, Item 1).
9. Disconnect hydraulic hose (Figure 4, Item 1) from upper hydraulic cylinder fitting (Figure 4, Item 2). Remove and discard O-ring.
10. Remove hydraulic hose (Figure 4, Item 1).

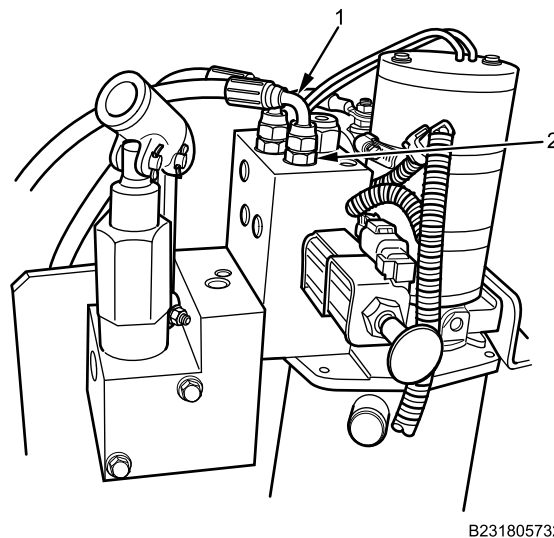

Figure 5. Hydraulic Power Module-to-Hydraulic Cylinder Hose Removal.

11. Place drain pan under hydraulic hose (Figure 5, Item 1).
12. Disconnect hydraulic hose (Figure 5, Item 1) from inner hydraulic power module fitting (Figure 5, Item 2). Remove and discard O-ring.

REAR DOOR/RAMP HYDRAULIC HOSES REMOVAL AND INSTALLATION (PULL-TYPE OPERATION) - (CONTINUED)

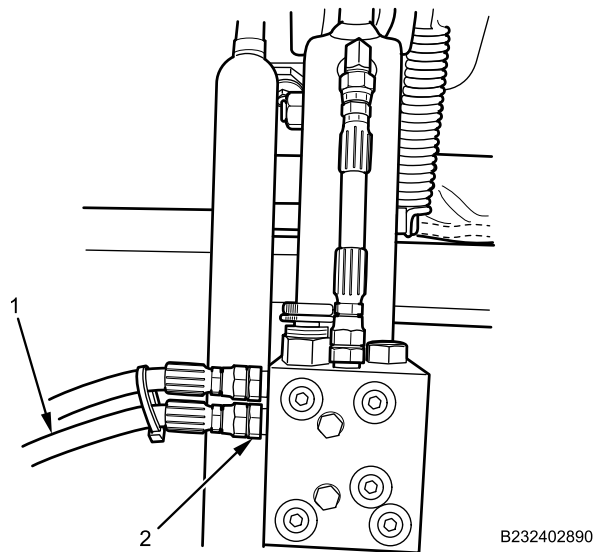

Figure 6. Hydraulic Power Module-to-Hydraulic Cylinder Hose Removal.

13. Place drain pan under hydraulic hose (Figure 6, Item 1).
14. Disconnect hydraulic hose (Figure 6, Item 1) from lower hydraulic cylinder fitting (Figure 6, Item 2). Remove and discard O-ring.
15. Remove lower hydraulic hose (Figure 6, Item 1).

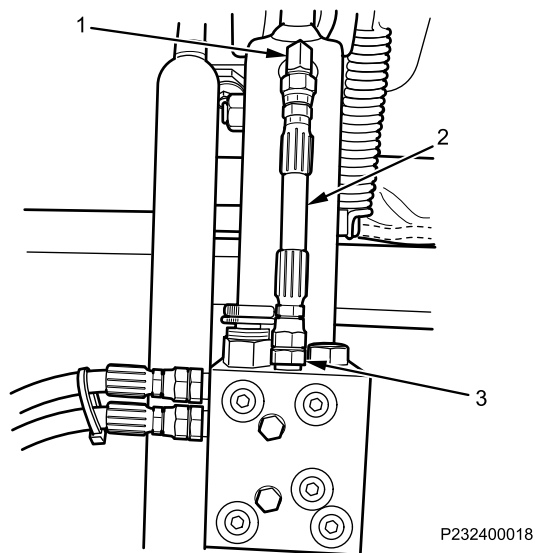
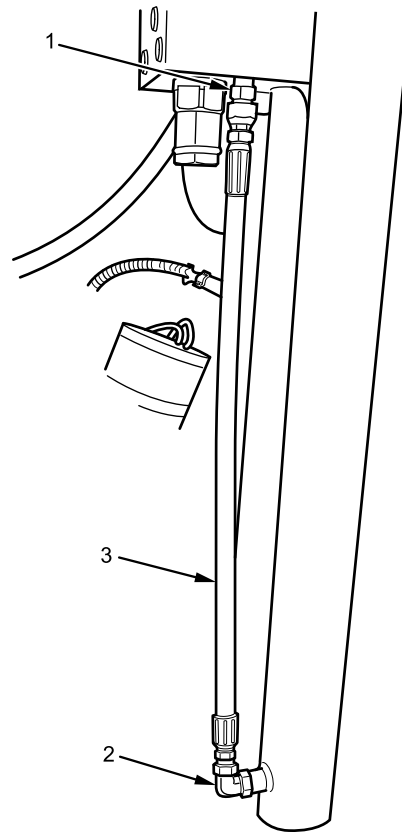

Figure 7. Hydraulic Cylinder Short Vertical Hose Removal.

16. Place drain pan under hydraulic hose (Figure 7, Item 2).
17. Disconnect hydraulic hose (Figure 7, Item 2) from lower hydraulic cylinder fitting (Figure 7, Item 3). Remove and discard O-ring.
18. Disconnect hydraulic hose (Figure 7, Item 2) from upper hydraulic cylinder fitting (Figure 7, Item 1). Remove and discard O-ring.
19. Remove hydraulic hose (Figure 7, Item 2).

**REAR DOOR/RAMP HYDRAULIC HOSES REMOVAL AND INSTALLATION (PULL-TYPE OPERATION) -
(CONTINUED)**

P232400011

Figure 8. Hydraulic Cylinder Long Vertical Hose Removal.

20. Place drain pan under hydraulic hose (Figure 8, Item 3).
21. Disconnect hydraulic hose (Figure 8, Item 3) from lower hydraulic cylinder fitting (Figure 8, Item 2). Remove and discard O-ring.
22. Disconnect hydraulic hose (Figure 8, Item 3) from upper hydraulic cylinder fitting (Figure 8, Item 1) and remove hydraulic hose (Figure 8, Item 3). Remove and discard O-ring.
23. Remove drain pan.
24. Clean up dirt, fluids, and contaminants with rag.

END OF TASK

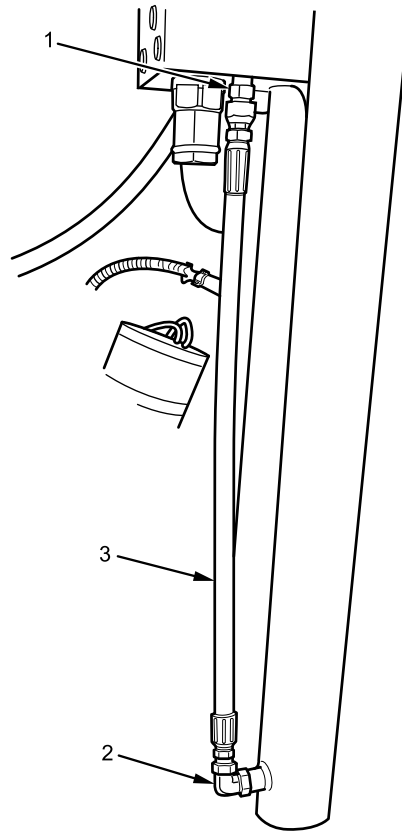
**REAR DOOR/RAMP HYDRAULIC HOSES REMOVAL AND INSTALLATION (PULL-TYPE OPERATION) -
(CONTINUED)****INSTALLATION**

P232400011

Figure 9. Hydraulic Cylinder Long Vertical Hose Installation.

1. Install new O-rings on fittings (Figure 9, Item 1 and 2).
2. Connect hydraulic hose (Figure 9, Item 3) on upper hydraulic cylinder fitting (Figure 9, Item 1).
3. Connect hydraulic hose (Figure 9, Item 3) on lower hydraulic cylinder fitting (Figure 9, Item 2).
4. Tighten and secure both hose ends.

REAR DOOR/RAMP HYDRAULIC HOSES REMOVAL AND INSTALLATION (PULL-TYPE OPERATION) - (CONTINUED)

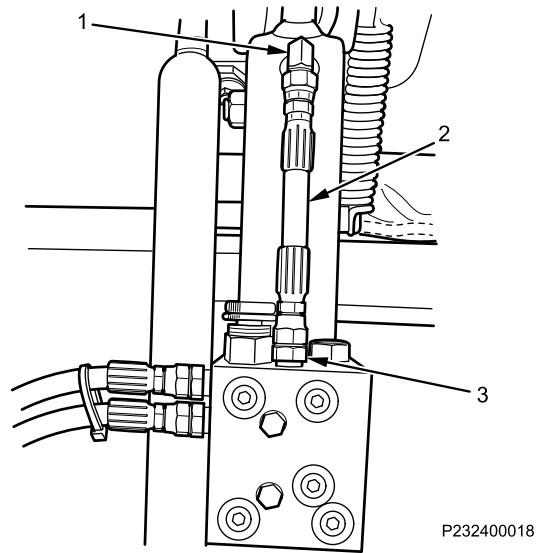

Figure 10. Hydraulic Cylinder Short Vertical Hose Installation.

5. Install new O-rings on fittings (Figure 10, Item 1 and 3).
6. Connect hydraulic hose (Figure 10, Item 2) on upper hydraulic cylinder fitting (Figure 10, Item 1).
7. Connect hydraulic hose (Figure 10, Item 2) on lower hydraulic cylinder fitting (Figure 10, Item 3).
8. Tighten and secure both hose ends.

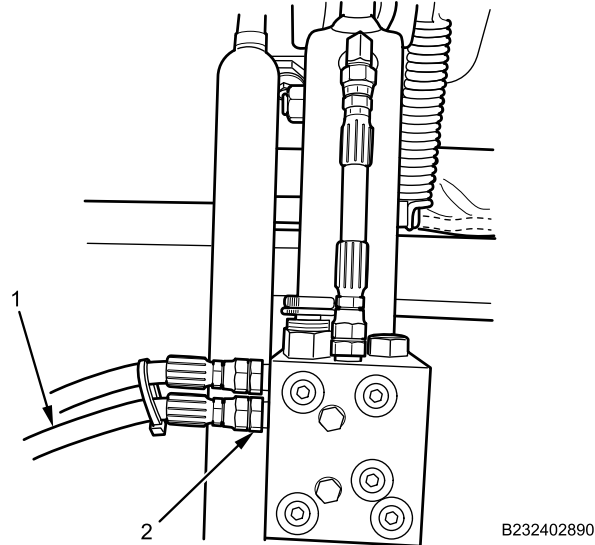
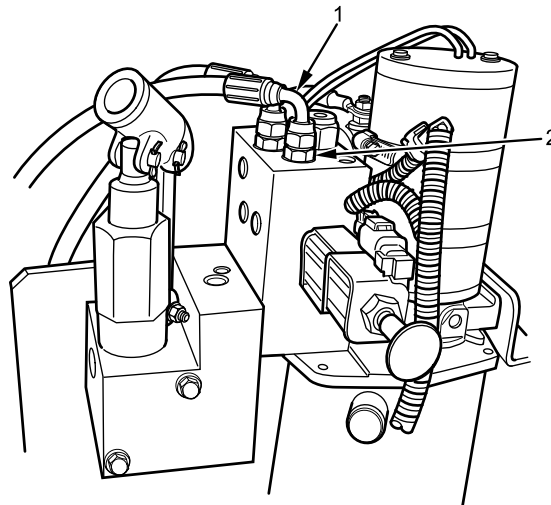

Figure 11. Hydraulic Power Module-to-Hydraulic Cylinder Hose Installation.

9. Install new O-ring on fitting (Figure 11, Item 2).
10. Connect hydraulic hose (Figure 11, Item 1) on lower hydraulic cylinder fitting (Figure 11, Item 2).

REAR DOOR/RAMP HYDRAULIC HOSES REMOVAL AND INSTALLATION (PULL-TYPE OPERATION) - (CONTINUED)



B231805732

Figure 12. Hydraulic Power Module-to-Hydraulic Cylinder Hose Installation.

11. Install new O-ring on fitting (Figure 12, Item 2).
12. Connect hydraulic hose (Figure 12, Item 1) on inner hydraulic power module fitting (Figure 12, Item 2).
13. Tighten and secure both hose ends.

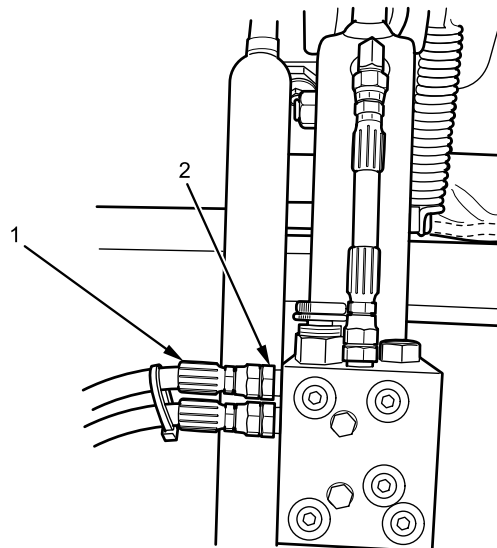

P232400013

Figure 13. Hydraulic Power Module-to-Hydraulic Cylinder Hose Installation.

14. Install new O-ring on fitting (Figure 13, Item 2).
15. Connect hydraulic hose (Figure 13, Item 1) on upper hydraulic cylinder fitting (Figure 13, Item 2).

REAR DOOR/RAMP HYDRAULIC HOSES REMOVAL AND INSTALLATION (PULL-TYPE OPERATION) - (CONTINUED)

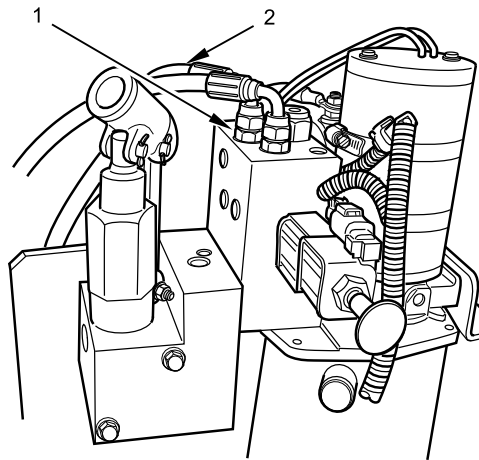

B231805731

Figure 14. Hydraulic Power Module-to-Hydraulic Cylinder Hose Installation.

16. Install new O-ring on fitting (Figure 14, Item 1).
17. Connect hydraulic hose (Figure 14, Item 2) on outer hydraulic power module fitting (Figure 14, Item 1).
18. Tighten and secure both hose ends.
19. Install cable lock straps as noted earlier.
20. Turn MAIN POWER switch on (TM 9-2355-106-10).

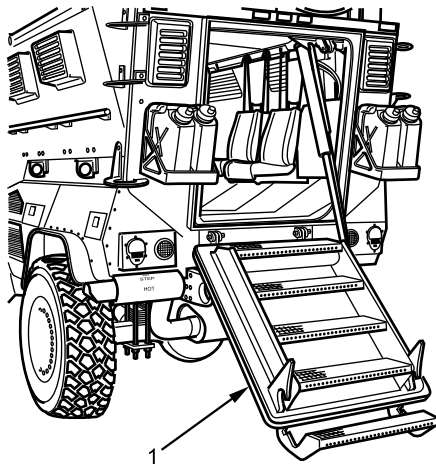

B231801603

Figure 15. Jackstand Removed from Rear Door/Ramp.

21. With assistant, raise rear door/ramp (Figure 15, Item 1) to closed position and remove jackstand.

REAR DOOR/RAMP HYDRAULIC HOSES REMOVAL AND INSTALLATION (PULL-TYPE OPERATION) - (CONTINUED)**WARNING**

Check for hydraulic leak location visually from at least an arm's length away and not within the path of the leak. If leak is suspected in a blind area, use scrap pieces of material such as cardboard or wood to check for location. Never use hand or other body parts. Failure to comply may result in serious injury, amputation, or death to personnel.

22. Open and close rear door/ramp (Figure 15, Item 1) to check for leaks and proper operation. Leave rear door/ramp in the closed position (TM 9-2355-106-10).
23. Turn MAIN POWER switch off (TM 9-2355-106-10).
24. Check rear door/ramp hydraulic fluid level (WP 0699).

END OF TASK**FOLLOW-ON MAINTENANCE**

1. Install rear door/ramp hydraulic pump cover (WP 0691).
2. Remove wheel chocks (TM 9-2355-106-10).

END OF TASK**END OF WORK PACKAGE**

FIELD MAINTENANCE
OUTSIDE GUNNER PROTECTION RISER REMOVAL AND INSTALLATION

INITIAL SETUP:**Tools and Special Tools**

General Mechanic's Tool Kit (GMTK)
(WP 0795, Item 37)
Lifting device (WP 0795, Item 67)
Lifting sling (WP 0795, Item 68)

TM 9-2355-106-23P
WP 0782

Equipment Condition

Parking brake set (TM 9-2355-106-10)
Transmission set in NEUTRAL (N) (TM
9-2355-106-10)
Engine off (TM 9-2355-106-10)
MAIN POWER switch off (TM 9-2355-106-10)
Wheels chocked (TM 9-2355-106-10)
Turret mounting plate removed (WP 0705)
Gun turret platform removed (WP 0704)
Outside gunner protection armor removed
(WP 0703)

Materials/Parts

Compound (WP 0794, Item 13)
Faceshield, industrial (WP 0794, Item 16)
Gloves (WP 0794, Item 18)
Gloves (WP 0794, Item 19)
Goggles, industrial (WP 0794, Item 20)

Personnel Required

Maintainer - (2)

References

TM 9-2355-106-10

WARNING

Armor parts are heavy. Use care when removing or installing. Do not attempt to lift without an assistant and lifting device. Wear gloves. Failure to comply may result in serious injury or death to personnel.

Prior to moving heavy components with lifting device, clear path of travel and clear personnel from area. Use proper lifting device for weight of item. Use extreme caution if lifting objects overhead or backing up. Stop and lower load as soon as possible. Failure to comply may result in damage to equipment and serious injury or death to personnel.

Use the appropriate lifting sling and chain hoist for the type of load. Clean lifting slings and chain hoists prior to use and inspect for damage such as wear, corrosion, elongation, tears, or punctures. Replace lifting slings and chain hoists that are damaged. Failure to comply may result in damage to equipment and injury or death to personnel.

OUTSIDE GUNNER PROTECTION RISER REMOVAL AND INSTALLATION - (CONTINUED)**REMOVAL**

1. Attach chain hoists (Figure 1, Item 4) to hole inside each corner of outside gunner protection riser (Figure 1, Item 1) and to lifting slings (Figure 1, Item 3).

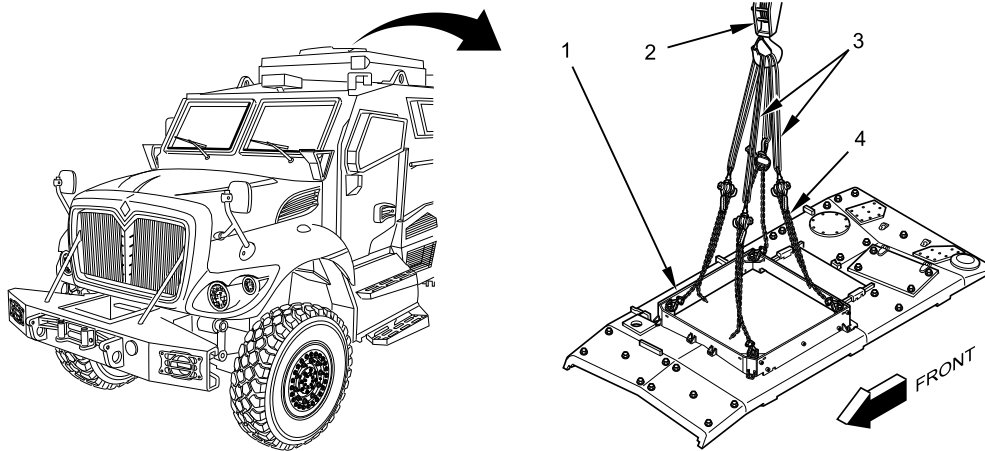

B231810659

Figure 1. Chain Hoists and Lifting Slings.

2. Secure lifting slings (Figure 1, Item 3) to lifting device (Figure 1, Item 2).
3. Tension chain hoists (Figure 1, Item 4) as required to remove slack.

OUTSIDE GUNNER PROTECTION RISER REMOVAL AND INSTALLATION - (CONTINUED)

4. Remove four bolts from each outside corner (Figure 2, Item 2) of outside gunner protection riser (Figure 2, Item 1).

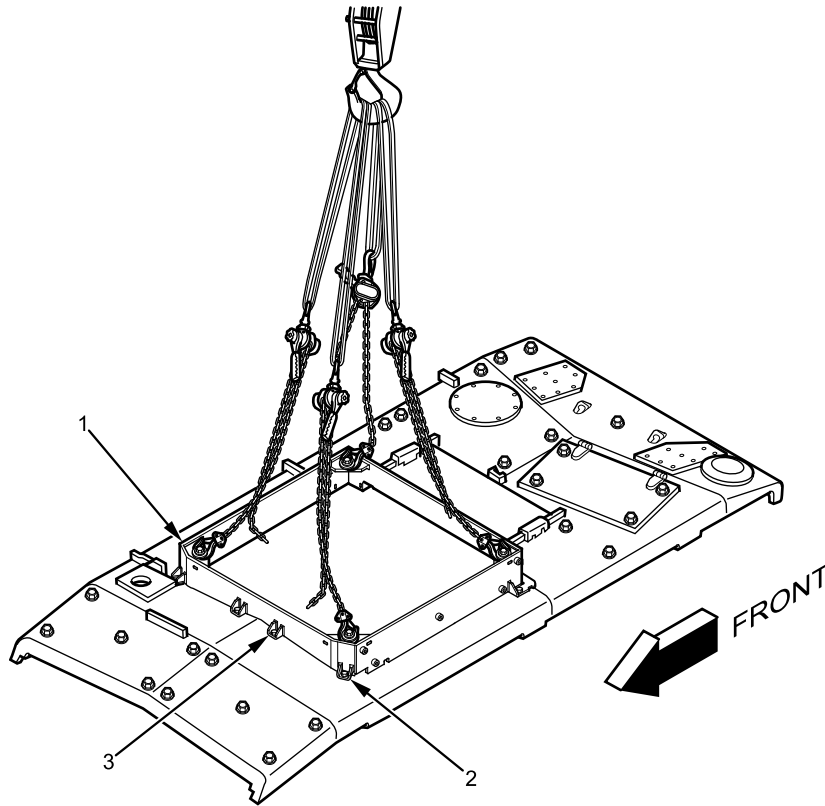

B231810658

Figure 2. Outside Gunner Protection Riser Removal.

5. Remove two bolts (Figure 2, Item 3) from front of outside gunner protection riser (Figure 2, Item 1).
6. With lifting device and assistant, remove outside gunner protection riser (Figure 2, Item 1) from roof and lower outside gunner protection riser (Figure 2, Item 1) to ground.
7. Remove chain hoists from outside gunner protection riser (Figure 2, Item 1).
8. Remove chain hoists and lifting slings from lifting device.

END OF TASK

OUTSIDE GUNNER PROTECTION RISER REMOVAL AND INSTALLATION - (CONTINUED)

INSTALLATION

WARNING



Corrosion preventive compound is toxic. Use only in well-ventilated area. Do not get in eyes; wear chemical safety goggles and full-face shield when using. Avoid contact with skin and wear rubber or plastic, solvent-resistant gloves. In case of contact, remove contaminated clothing and immediately wash area with soap and water. If compound contacts eyes, flush eyes with large amounts of water for at least 15 minutes and get immediate medical attention. If swallowed, do not induce vomiting; contact a physician immediately. Failure to comply may result in serious injury or death to personnel.

NOTE

Apply corrosion preventive compound to all outside gunner protection riser bolts before installation.

1. Attach chain hoists (Figure 3, Item 4) to hole inside each corner of outside gunner protection riser (Figure 3, Item 1).

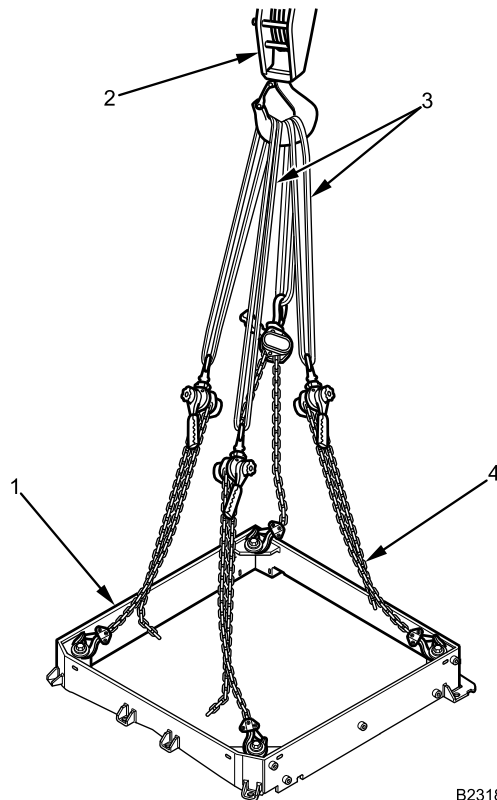

B231810660

Figure 3. Chain Hoists and Lifting Slings.

2. Secure lifting slings (Figure 3, Item 3) to lifting device (Figure 3, Item 2).
3. Tension chain hoists (Figure 3, Item 4) as required to remove chain slack.

OUTSIDE GUNNER PROTECTION RISER REMOVAL AND INSTALLATION - (CONTINUED)

4. With lifting device and assistant, raise outside gunner protection riser (Figure 4, Item 1) and lower on roof.

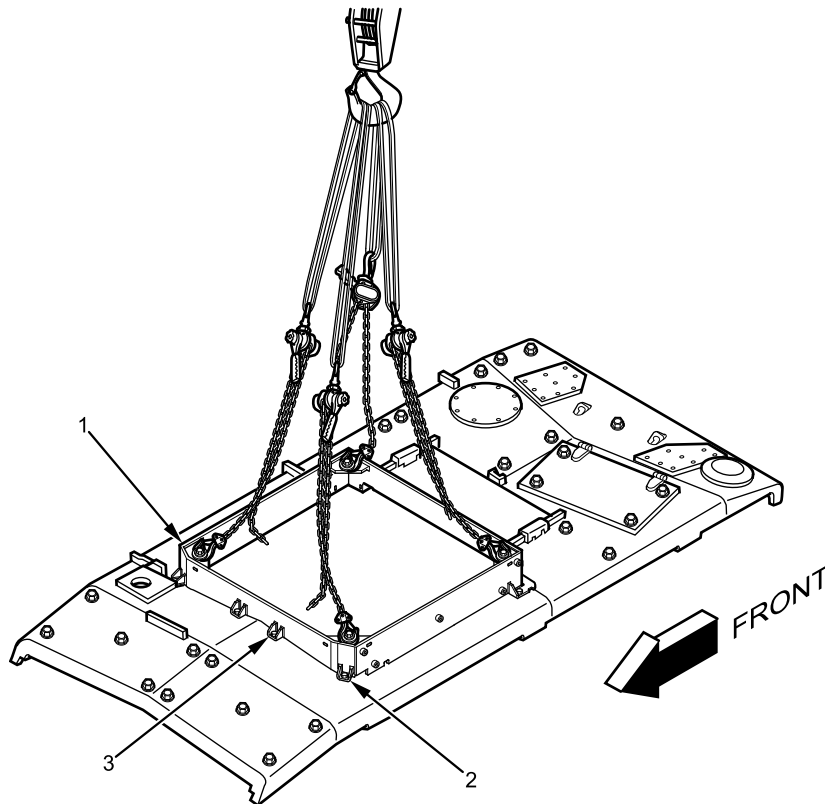

B231810658

Figure 4. Outside Gunner Riser Bolts Installation.

5. Install two bolts (Figure 4, Item 3) on front of outside gunner protection riser (Figure 4, Item 1).
6. Install four bolts on each outside corner (Figure 4, Item 2) of outside gunner protection riser (Figure 4, Item 1).
7. Tighten all outside gunner protection riser bolts securely.
8. Remove chain hoists from outside gunner protection riser.
9. Remove chain hoists and lifting slings from lifting device.

END OF TASK**FOLLOW-ON MAINTENANCE**

1. Install outside gunner protection armor (WP 0703).
2. Install gun turret platform (WP 0704).
3. Install turret mounting plate (WP 0705).
4. Remove wheel chocks (TM 9-2355-106-10).

END OF TASK**END OF WORK PACKAGE**

FIELD MAINTENANCE**OUTSIDE GUNNER PROTECTION ARMOR REMOVAL AND INSTALLATION**

INITIAL SETUP:**Tools and Special Tools**

General Mechanic's Tool Kit (GMTK)
(WP 0795, Item 37)

Materials/Parts

Compound (WP 0794, Item 13)
Faceshield, industrial (WP 0794, Item 16)
Gloves (WP 0794, Item 18)
Gloves (WP 0794, Item 19)
Goggles, industrial (WP 0794, Item 20)

Personnel Required

Maintainer - (2)

References

TM 9-2355-106-10
TM 9-2355-106-23P
WP 0782

Equipment Condition

Parking brake set (TM 9-2355-106-10)
Transmission set in NEUTRAL (N) (TM
9-2355-106-10)
Engine off (TM 9-2355-106-10)
MAIN POWER switch off (TM 9-2355-106-10)
Wheels chocked (TM 9-2355-106-10)

NOTE

This procedure is the same for right and left side gunner protection armor. Left side procedure shown.

OUTSIDE GUNNER PROTECTION ARMOR REMOVAL AND INSTALLATION - (CONTINUED)**REMOVAL****WARNING**

Secure armor before removal of final bolt to prevent armor from falling. Failure to comply may result in damage to equipment and serious injury or death to personnel.

1. With assistant, remove five bolts (Figure 1, Item 1) washers (Figure 1, Item 2), and outside gunner protection armor (Figure 1, Item 4) from riser.

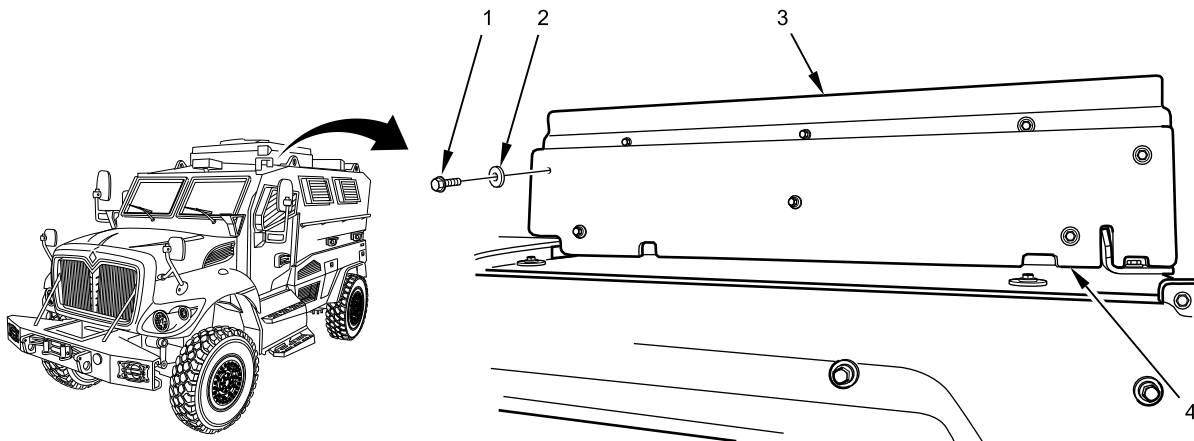

B233410715

Figure 1. Gunner Protection Armor.

END OF TASK

OUTSIDE GUNNER PROTECTION ARMOR REMOVAL AND INSTALLATION - (CONTINUED)

INSTALLATION

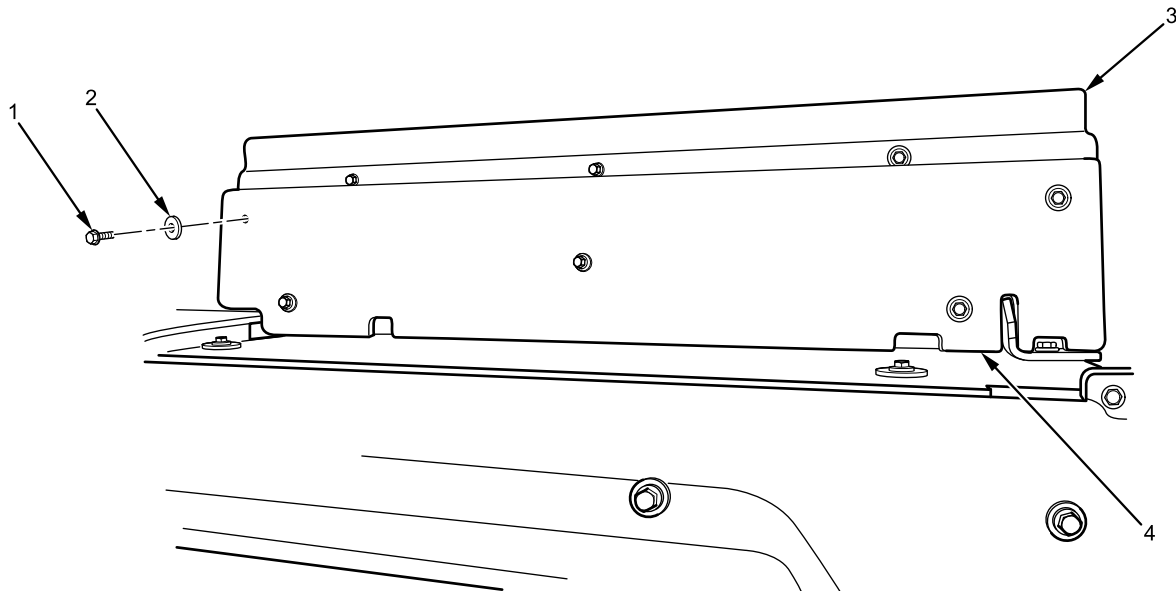

B233410716

Figure 2. Gunner Protection Armor.

WARNING



Corrosion preventive compound is toxic. Use only in well-ventilated area. Do not get in eyes; wear chemical safety goggles and full-face shield when using. Avoid contact with skin and wear rubber or plastic, solvent-resistant gloves. In case of contact, remove contaminated clothing and immediately wash area with soap and water. If compound contacts eyes, flush eyes with large amounts of water for at least 15 minutes and get immediate medical attention. If swallowed, do not induce vomiting; contact a physician immediately. Failure to comply may result in serious injury or death to personnel.

1. Apply corrosion preventive compound on five gunner protection armor mounting bolts (Figure 2, Item 2).
2. With assistant, install gunner protection armor (Figure 2, Item 4) on riser (Figure 2, Item 3) with five bolts (Figure 2, Item 1) and washers (Figure 2, Item 2). Tighten bolts (Figure 2, Item 1) securely.

END OF TASK

OUTSIDE GUNNER PROTECTION ARMOR REMOVAL AND INSTALLATION - (CONTINUED)**FOLLOW-ON MAINTENANCE**

1. Remove wheel chocks (TM 9-2355-106-10).

END OF TASK**END OF WORK PACKAGE**

FIELD MAINTENANCE**GUN TURRET PLATFORM REMOVAL AND INSTALLATION**

INITIAL SETUP:**Tools and Special Tools**

General Mechanic's Tool Kit (GMTK)
(WP 0795, Item 37)
Belly Armor Removal/Installer Kit (WP 0795, Item
16)
Lifting sling (WP 0795, Item 68)
Lifting device (WP 0795, Item 67)

Materials/Parts

Goggles, industrial (WP 0794, Item 20)
Faceshield, industrial (WP 0794, Item 16)
Compound (WP 0794, Item 13)
Gloves (WP 0794, Item 19)
Gloves (WP 0794, Item 18)

Personnel Required

Maintainer - (2)

References

TM 9-2355-106-10
TM 9-2355-106-23P
WP 0786
WP 0782

Equipment Condition

Parking brake set (TM 9-2355-106-10)
Transmission set in NEUTRAL (N) (TM
9-2355-106-10)
Engine off (TM 9-2355-106-10)
MAIN POWER switch off (TM 9-2355-106-10)
Wheels chocked (TM 9-2355-106-10)
Turret mounting plate removed (WP 0705)

WARNING

Armor parts are heavy. Use care when removing or installing. Do not attempt to lift without an assistant and lifting device. Wear gloves. Failure to comply may result in serious injury or death to personnel.

Prior to moving heavy components with lifting device, clear path of travel and clear personnel from area. Use proper lifting device for weight of item. Use extreme caution if lifting objects overhead or backing up. Stop and lower load as soon as possible. Failure to comply may result in damage to equipment and serious injury or death to personnel.

Use the appropriate lifting sling and chain hoist for the type of load. Clean lifting slings and chain hoists prior to use and inspect for damage such as wear, corrosion, elongation, tears, or punctures. Replace lifting slings and chain hoists that are damaged. Failure to comply may result in damage to equipment and injury or death to personnel.

GUN TURRET PLATFORM REMOVAL AND INSTALLATION - (CONTINUED)

REMOVAL

1. Attach chain hoists (Figure 1, Item 4) at each corner of gun turret platform (Figure 1, Item 1) and to lifting slings (Figure 1, Item 3).

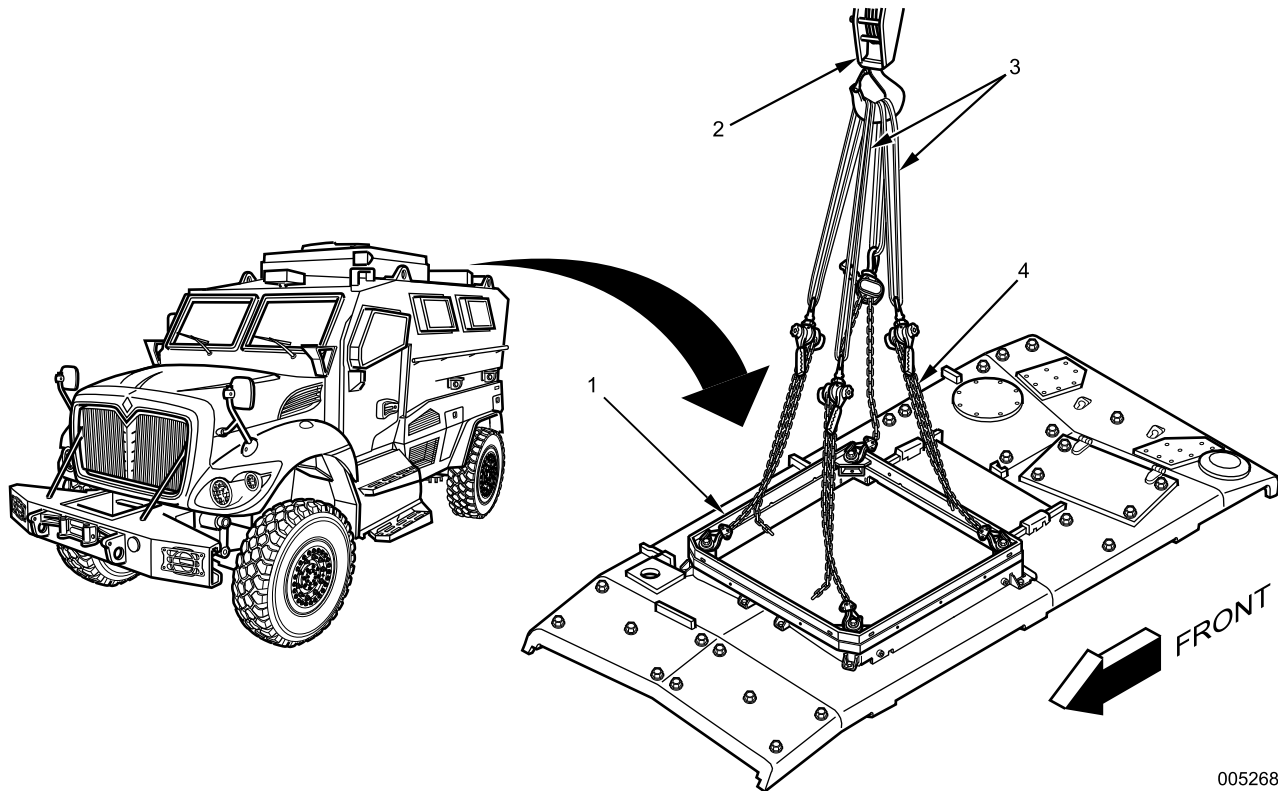

005268

Figure 1. Chain Hoists and Lifting Slings.

2. Secure lifting slings (Figure 1, Item 3) in lifting device (Figure 1, Item 2).
3. Apply tension to chain hoists (Figure 1, Item 4) as required to remove slack.

NOTE

Gun turret platform is attached to outside gunner protection riser at each inside corner.

4. Remove four nuts (Figure 2, Item 9), support mounting plates (Figure 2, Item 8 and 10), flat washers (Figure 2, Item 4), and bolts (Figure 2, Item 5) from gun turret platform (Figure 2, Item 1).

GUN TURRET PLATFORM REMOVAL AND INSTALLATION - (CONTINUED)

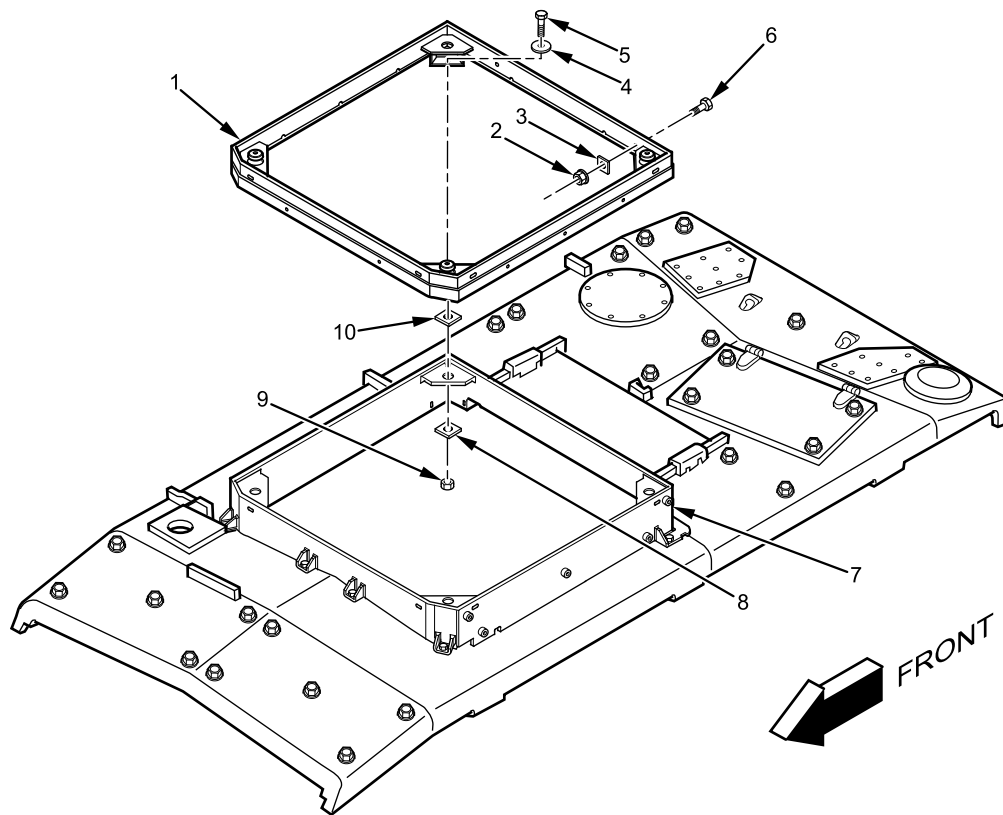

B231810653

Figure 2. Gun Turret Removal.

5. With assistant holding flange bolts (Figure 2, Item 6) on exterior side of gun turret platform (Figure 2, Item 1), remove 10 flange nuts (Figure 2, Item 2) and mounting plates (Figure 2, Item 3). Remove flange bolts.
6. With lifting device and assistant, lift gun turret platform (Figure 2, Item 1) from outside gunner protection riser (Figure 2, Item 7), and lower gun turret platform to ground.
7. Remove chain hoists from gun turret platform (Figure 2, Item 1).
8. Remove chain hoists and lifting slings from lifting device.

END OF TASK

GUN TURRET PLATFORM REMOVAL AND INSTALLATION - (CONTINUED)**INSTALLATION****WARNING**

Corrosion preventive compound is toxic. Use only in well-ventilated area. Do not get in eyes; wear chemical safety goggles and full-face shield when using. Avoid contact with skin and wear rubber or plastic, solvent-resistant gloves. In case of contact, remove contaminated clothing and immediately wash area with soap and water. If compound contacts eyes, flush eyes with large amounts of water for at least 15 minutes and get immediate medical attention. If swallowed, do not induce vomiting; contact a physician immediately. Failure to comply may result in serious injury or death to personnel.

NOTE

Apply corrosion preventive compound to all gun turret platform bolts before installation.

GUN TURRET PLATFORM REMOVAL AND INSTALLATION - (CONTINUED)

1. Attach chain hoists (Figure 3, Item 4) to each corner of gun turret platform (Figure 3, Item 1) and to lifting slings (Figure 3, Item 3).

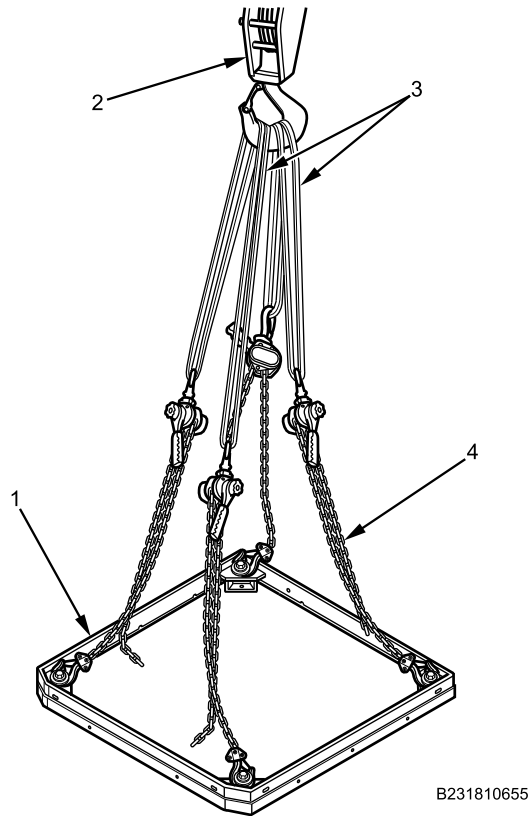
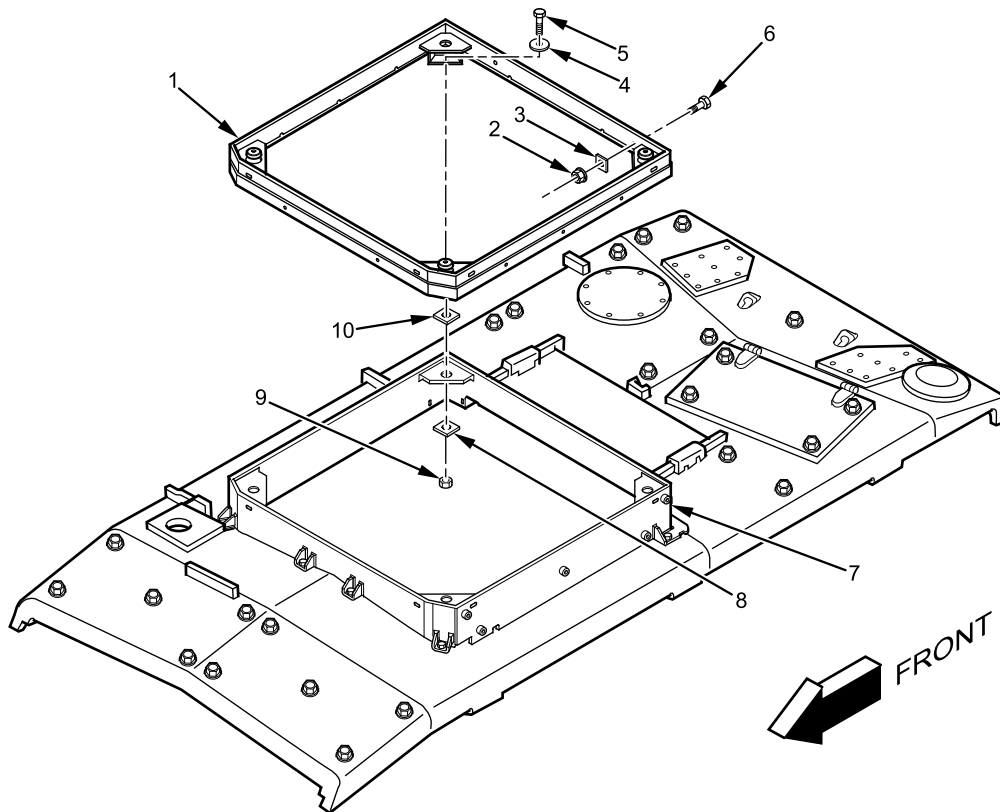

Figure 3. Chain Hoists and Lifting Slings.

2. Secure lifting slings (Figure 3, Item 3) in lifting device (Figure 3, Item 2).
3. Apply tension to chain hoists (Figure 3, Item 4) as required to remove slack.

GUN TURRET PLATFORM REMOVAL AND INSTALLATION - (CONTINUED)

4. With lifting device and assistant, position gun turret platform (Figure 4, Item 1) onto outside gunner protection riser (Figure 4, Item 7).



B231810653

Figure 4. Gun Turret Platform Installation.

5. Install 10 flange bolts (Figure 4, Item 6), mounting plates (Figure 4, Item 3), and flange nuts (Figure 4, Item 2) on gun turret platform (Figure 4, Item 1).
6. With assistant holding flange bolts (Figure 4, Item 6) on exterior side of gun turret platform (Figure 4, Item 1), tighten flange nuts (Figure 4, Item 2) securely.
7. Install four bolts (Figure 4, Item 5), flat washers (Figure 4, Item 4), support mounting plates (Figure 4, Item 8 and 10), and nuts (Figure 4, Item 9) on gun turret platform (Figure 4, Item 1). Tighten bolts securely.
8. Remove chain hoists from gun turret platform (Figure 4, Item 1).
9. Remove chain hoists and lifting slings from lifting device.

END OF TASK**FOLLOW-ON MAINTENANCE**

1. Install turret mounting plate (WP 0705).
2. Remove wheel chocks (TM 9-2355-106-10).

END OF TASK**END OF WORK PACKAGE**

FIELD MAINTENANCE**TURRET MOUNTING PLATE REMOVAL AND INSTALLATION**

INITIAL SETUP:**Tools and Special Tools**

General Mechanic's Tool Kit (GMTK)
(WP 0795, Item 37)
Lifting device (WP 0795, Item 67)
Lifting sling (WP 0795, Item 68)
Wrench, torque, 20-100 lb-ft, 3/8-inch drive
(WP 0795, Item 141)

Materials/Parts

Faceshield, industrial (WP 0794, Item 16)
Gloves (WP 0794, Item 18)
Gloves (WP 0794, Item 19)
Sealing compound (WP 0794, Item 45)

Personnel Required

Maintainer - (2)

References

TM 9-2355-106-10
TM 9-2355-106-23P
WP 0782

Equipment Condition

Parking brake set (TM 9-2355-106-10)
Transmission set in NEUTRAL (N) (TM
9-2355-106-10)
Engine off (TM 9-2355-106-10)
MAIN POWER switch off (TM 9-2355-106-10)
Wheels chocked (TM 9-2355-106-10)

WARNING

Armor parts are heavy. Use care when removing or installing. Do not attempt to lift without an assistant and lifting device. Wear gloves. Failure to comply may result in serious injury or death to personnel.

Prior to moving heavy components with lifting device, clear path of travel and clear personnel from area. Use proper lifting device for weight of item. Use extreme caution if lifting objects overhead or backing up. Stop and lower load as soon as possible. Failure to comply may result in damage to equipment and serious injury or death to personnel.

Use the appropriate lifting sling for the type of load. Always clean and inspect lifting slings prior to use. Inspect for damage such as wear, corrosion, elongation, tears, or punctures. Replace lifting slings that are damaged. Failure to comply may result in component damage and death or injury to personnel.

TURRET MOUNTING PLATE REMOVAL AND INSTALLATION - (CONTINUED)**REMOVAL****NOTE**

Turret mounting plate is installed on gun turret platform by four attachment points at each of the inside corners.

1. Remove four nuts (Figure 1, Item 9), washers (Figure 1, Item 10), isolator plates (Figure 1, Item 8), rubber mounts (Figure 1, Item 7), mounting spacers (Figure 1, Item 6), rubber mounts (Figure 1, Item 5), isolator plates (Figure 1, Item 4), flat washers (Figure 1, Item 3), and bolts (Figure 1, Item 2) from turret mounting plate (Figure 1, Item 1) on gun turret platform (Figure 1, Item 11).

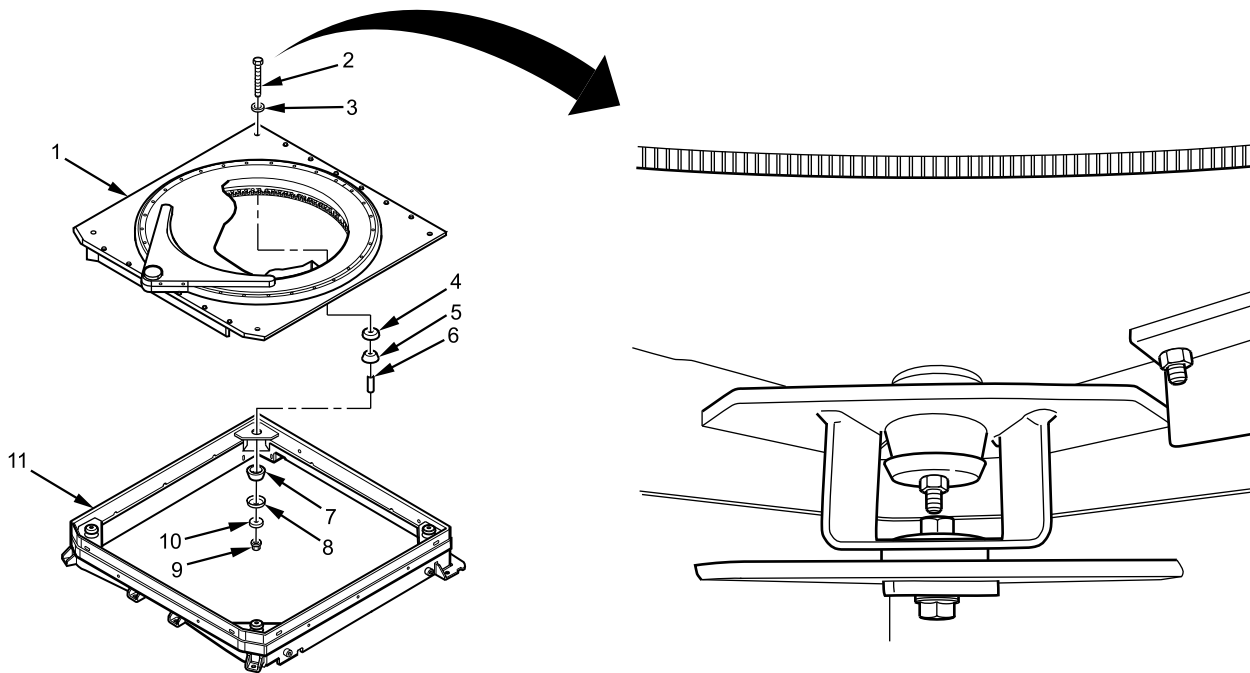

B233403371

Figure 1. Turret Mounting Plate Bolts Removal.

TURRET MOUNTING PLATE REMOVAL AND INSTALLATION - (CONTINUED)**WARNING**

Ensure turret ring is locked into a position that will properly balance the load when removing turret mounting plate. Failure to comply may result in damage to equipment and serious injury or death to personnel.

2. Secure lifting slings (Figure 2, Item 2) to turret mounting plate (Figure 2, Item 1) and attach lifting slings to lifting device.

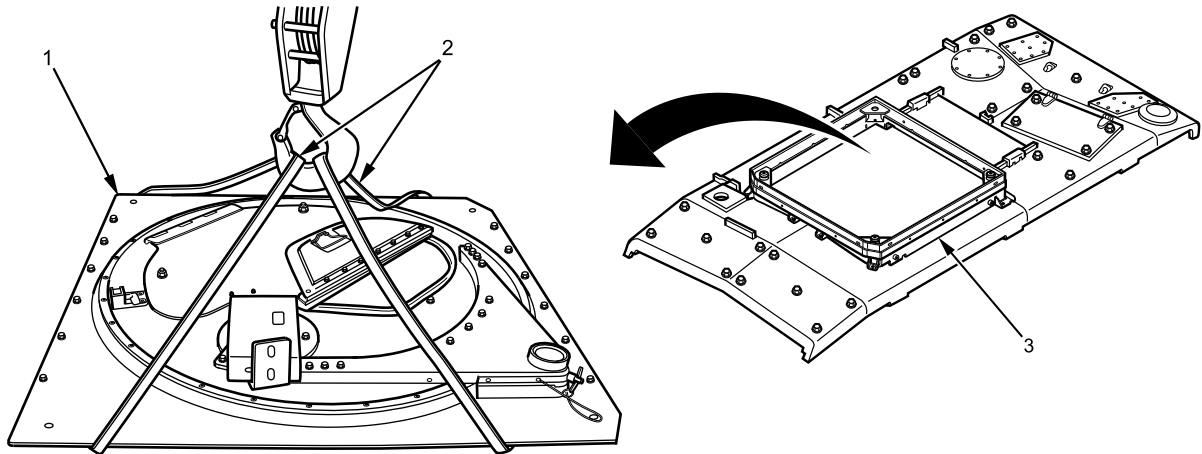

B233403372

Figure 2. Turret Mounting Plate Removal.

3. With assistant, remove turret mounting plate (Figure 2, Item 1) from gun turret platform (Figure 2, Item 3).

END OF TASK

TURRET MOUNTING PLATE REMOVAL AND INSTALLATION - (CONTINUED)

INSTALLATION

WARNING



Thread sealing compound is harmful to skin and eyes. If thread sealing compound contacts eyes, rinse thoroughly and contact physician if irritation persists. If skin is contacted, wash thoroughly with soap and water. Failure to comply may result in serious injury to personnel.

NOTE

Apply sealing compound to all turret mounting plate bolt threads.

1. Secure lifting slings (Figure 3, Item 2) to turret mounting plate (Figure 3, Item 1) and attach lifting slings to lifting device.

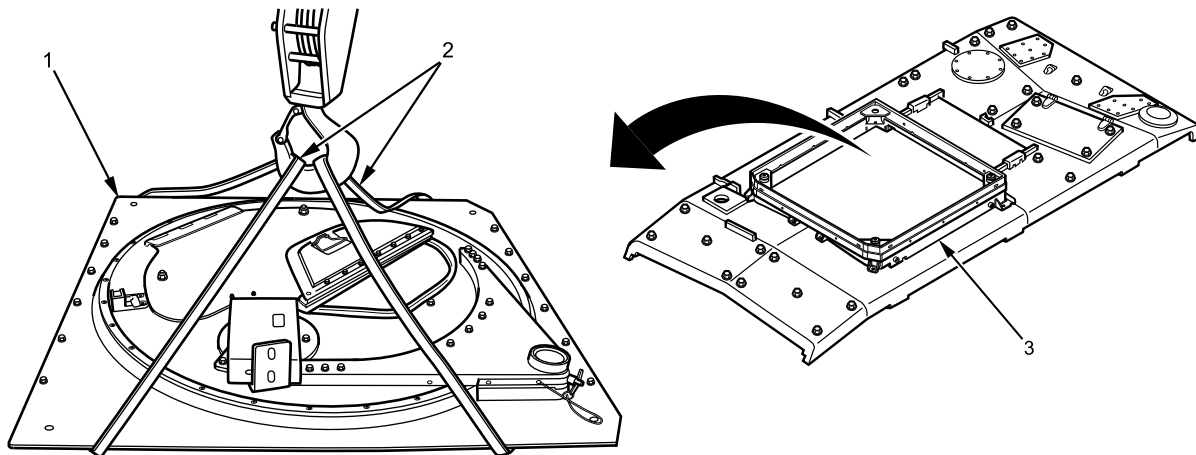

B233403372

Figure 3. Turret Mounting Plate Installation.

2. With assistant, install turret mounting plate (Figure 3, Item 1) on gun turret platform (Figure 3, Item 3).
3. Install four bolts (Figure 4, Item 2), flat washers (Figure 4, Item 3), isolator plates (Figure 4, Item 4), rubber mounts (Figure 4, Item 5), mounting spacers (Figure 4, Item 6), rubber mounts (Figure 4, Item 7), isolator plates (Figure 4, Item 8), washers (Figure 4, Item 10), and nuts (Figure 4, Item 9) to turret mounting plate (Figure 4, Item 1) on gun turret platform (Figure 4, Item 11). Torque bolts to 32 lb-ft (43 N•m).

TURRET MOUNTING PLATE REMOVAL AND INSTALLATION - (CONTINUED)

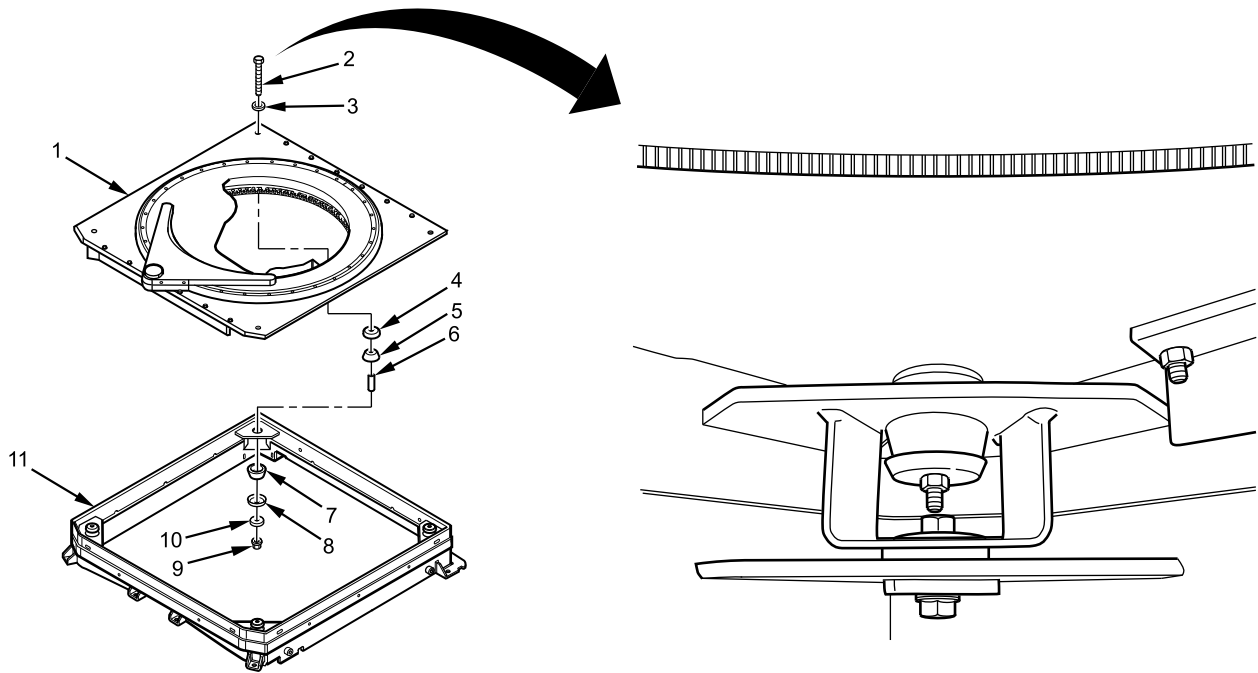

B233403371

Figure 4. Turret Mounting Plate Bolts Installation.

END OF TASK

FOLLOW-ON MAINTENANCE

1. Remove wheel chocks (TM 9-2355-106-10).

END OF TASK

END OF WORK PACKAGE

FIELD MAINTENANCE
RIFLE RACK REMOVAL AND INSTALLATION

INITIAL SETUP:**Tools and Special Tools**

General Mechanic's Tool Kit (GMTK)
(WP 0795, Item 37)

References

TM 9-2355-106-10
TM 9-2355-106-23P
WP 0782

Equipment Condition

Parking brake set (TM 9-2355-106-10)
Transmission set in NEUTRAL (N) (TM
9-2355-106-10)
Engine off (TM 9-2355-106-10)
MAIN POWER switch off (TM 9-2355-106-10)
Wheels chocked (TM 9-2355-106-10)

WARNING

Remove rifles from rifle racks being worked on. Ensure rifles are not loaded and store in safe manner. Failure to comply may result in serious injury or death to personnel.

RIFLE RACK REMOVAL AND INSTALLATION - (CONTINUED)**REMOVAL**

1. Remove three bolts (Figure 1, Item 2) securing rifle mount bracket (Figure 1, Item 1) to wall. Remove rifle mount bracket.

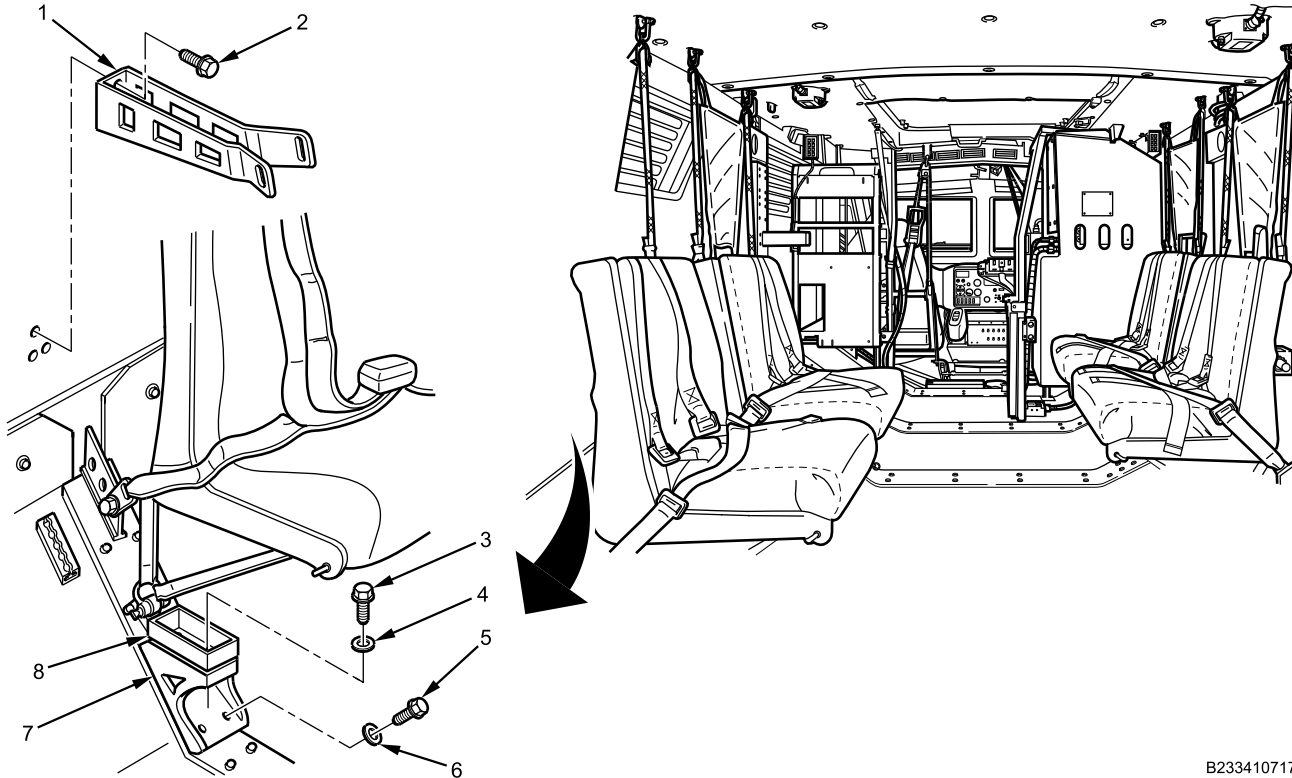

B233410717

Figure 1. Rifle Rack.

2. Remove two bolts (Figure 1, Item 3) and washers (Figure 1, Item 4) securing rifle base support (Figure 1, Item 8) to mount support (Figure 1, Item 7). Remove rifle base support.
3. Remove four bolts (Figure 1, Item 5) and washers (Figure 1, Item 6) securing rifle mount support (Figure 1, Item 7) to wall. Remove rifle mount support.

END OF TASK**INSTALLATION**

1. Install rifle mount bracket (Figure 2, Item 1) on wall with three bolts (Figure 2, Item 2). Tighten bolts securely.

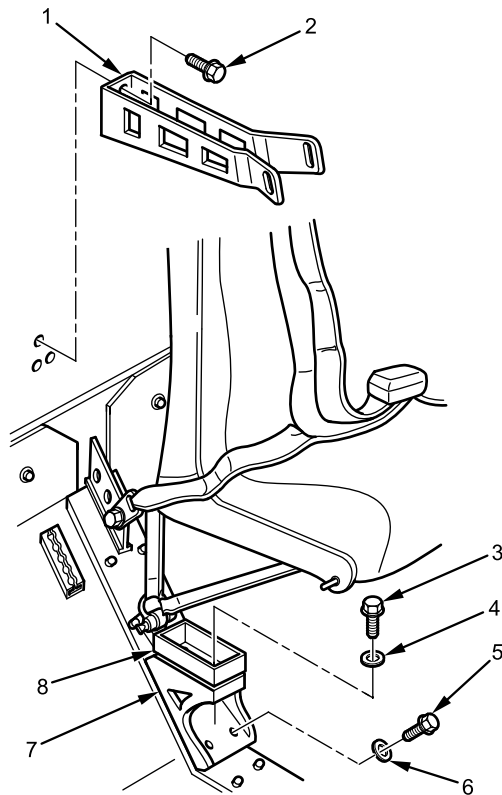
RIFLE RACK REMOVAL AND INSTALLATION - (CONTINUED)

B233410718

Figure 2. Rifle Rack.

2. Install rifle mount support (Figure 2, Item 7) on wall with four bolts (Figure 2, Item 5) and washers (Figure 2, Item 6). Tighten bolts securely.
3. Install rifle base support (Figure 2, Item 8) on mount support (Figure 2, Item 7) with two bolts (Figure 2, Item 3) and washers (Figure 2, Item 4). Tighten bolts securely.

END OF TASK**FOLLOW-ON MAINTENANCE**

1. Remove wheel chocks (TM 9-2355-106-10).

END OF TASK**END OF WORK PACKAGE**

FIELD MAINTENANCE**HEATING VENTILATING AND AIR CONDITIONING (HVAC) SERVICE/RECHARGE PROCEDURE**

INITIAL SETUP:**Tools and Special Tools**

Refrigeration Ordnance Service Tool Kit
(WP 0795, Item 85)
Refrigerant recovery station (WP 0795, Item 84)
Gloves, rubber (WP 0795, Item 38)

Materials/Parts

Faceshield, industrial (WP 0794, Item 16)
Goggles, industrial (WP 0794, Item 20)
Lubricating oil (WP 0794, Item 31)
Refrigerant (WP 0794, Item 54)

Personnel Required

Maintainer (HVAC certified) - (2)

References

TM 9-2355-106-10
TM 9-2355-106-23P
WP 0782

Equipment Condition

Parking brake set (TM 9-2355-106-10)
Transmission set in NEUTRAL (N) (TM
9-2355-106-10)
Engine off (TM 9-2355-106-10)
MAIN POWER switch off (TM 9-2355-106-10)
Wheels chocked (TM 9-2355-106-10)
Engine hood open and secured (TM 9-2355-106-10)

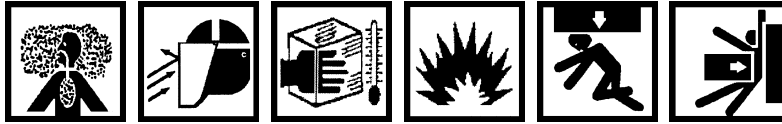
**HEATING VENTILATING AND AIR CONDITIONING (HVAC) SERVICE/RECHARGE PROCEDURE -
(CONTINUED)****WARNING**

Carbon monoxide is a colorless, odorless, and dangerous gas that deprives the body of oxygen and causes suffocation. Use the following precautions to avoid carbon monoxide poisoning. Failure to comply may result in permanent brain damage or death to personnel.

Do not idle engine for long periods of time.

If necessary to run engine in confined area during vehicle service, use proper equipment to vent exhaust gasses outside work area.

Do not operate personnel heater in enclosed area without adequate ventilation.

Turn auxiliary diesel heater switch off before filling any fuel tank on vehicle.

Do not sleep in vehicle with heater operating or engine idling.

Be alert at all times for exhaust odors and symptoms of exposure to carbon monoxide, such as headaches, dizziness, loss of muscular control, apparent drowsiness, and coma. If symptoms are evident, move affected personnel to fresh air, keep them warm, do not permit physical exercise, administer artificial respiration (if necessary), and seek immediate medical attention.

The temperature of liquid refrigerant is -20°F (-29°C). Wear full face shield, protective rubberized gloves, and protective clothing when working with refrigerant. If refrigerant contacts skin, remove all contaminated clothing. Treat skin as though it were frostbitten or frozen and seek immediate medical attention. If refrigerant contacts eyes, do not rub them. Flush eyes with cold water for at least 15 minutes to gradually increase temperature above freezing point. Seek immediate medical attention. Failure to comply may result in serious injury or death to personnel.

Do not expose refrigerant containers, empty or full, to open flames or temperatures above 125°F (52°C). Do not discard empty containers where they may be subject to heat from a trash burner; containers may explode. Failure to comply may result in damage to equipment and serious injury or death to personnel.

R-134a refrigerant must not be mixed with air and then pressurized. When mixed with large quantities of air and pressurized, R-134a becomes combustible. Failure to comply may result in damage to equipment and environment, and serious injury or death to personnel.

Federal and state laws require that refrigerant be recovered and recycled. Refrigerant must be recovered from system with authorized recommended equipment before any work can be performed on unit. Always use approved recycling equipment to prevent accidental discharge. Failure to comply may result in damage to equipment and environment, and serious injury or death to personnel.

Refrigerant evaporates very quickly and may displace oxygen surrounding work area, especially in a small or enclosed area. This can cause suffocation or brain damage. If leak occurs, avoid breathing refrigerant vapor and thoroughly ventilate area before continuing service. If personnel breathe refrigerant vapors, obtain immediate medical assistance. Failure to comply may result in serious injury or death to personnel.

HEATING VENTILATING AND AIR CONDITIONING (HVAC) SERVICE/RECHARGE PROCEDURE - (CONTINUED)

Do not install or remove air-conditioning testing or charging equipment while engine is running. Wait 30 seconds after engine shutdown to allow high side and low side pressures to equalize. Failure to comply may result in damage to equipment and environment, and serious injury or death to personnel.

Refrigerant becomes a poisonous gas in the presence of heat. Do not smoke or allow any type of flame in immediate area while servicing air conditioning system. Never weld, solder, steam clean, or use excessive heat on any part of the air conditioning system while charged/pressurized. Failure to comply may result in damage to equipment and serious injury or death to personnel.

Do not check compressor oil level when HVAC system is charged with refrigerant. Never open the high side hand valve of the manifold gauge set while HVAC system is operating. If hot, high pressure refrigerant is forced through gauge to refrigerant supply cylinder, which could rupture. Do not disconnect HVAC lines from compressor. Release of refrigerant may cause damage to equipment or environment and serious injury or death to personnel.

Do not use parts other than those specified for the system being serviced. Failure to comply may result in damage to equipment and serious injury or death to personnel.

Accidental or intentional introduction of liquid contaminants into the environment is a violation of state, federal, and military regulations. Store, install, and dispose of containers in accordance with standard operating procedures. Failure to comply may result in damage to environment and serious injury or death to personnel.

Engine hood is extremely heavy and requires two-person lift. Ensure that there is adequate space in front of the vehicle to open hood completely without pinning or pinching personnel between hood and any other structure. Use extreme care when working under hood and make sure it is properly supported. Failure to comply may result in serious injury or death to personnel.

Valve for electronic vacuum gauge must be closed until you are instructed to open it. If valve is open during system charging, excess pressure may damage electronic vacuum gauge.

HEATING VENTILATING AND AIR CONDITIONING (HVAC) SERVICE/RECHARGE PROCEDURE - (CONTINUED)

CAUTION

When charging air conditioning system, keep refrigerant tank upright. If tank is not in upright position, liquid refrigerant may enter system and cause compressor damage.

Overcharging system will result in excessively high head pressures during operation and may damage compressor.

RECOVERY PROCEDURE

NOTE

Vehicles are filled with Polyalkylene Glycol (PAG) oil that incorporates Ultra-Violet (UV) dye during the manufacturing process. UV light may be helpful in locating refrigerant leaks.

1. Check all A/C components and connections for leaks with refrigerant leak detector before recovering refrigerant from A/C system.
2. Prepare the recovery/recharging station according to the setup instructions described in the recovery/recharging station user's guide.
3. Remove protective cap and connect recovery/recharging station BLUE hose to low-side service port (Figure 1, Item 1) on low-side line (Figure 1, Item 2).

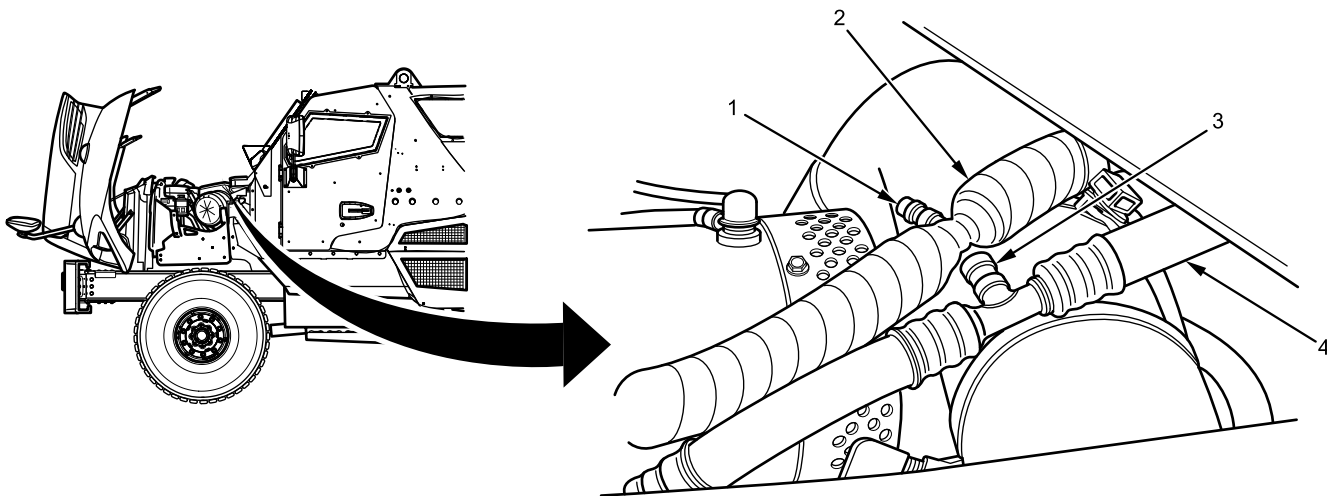

B235210597

Figure 1. HVAC Service Ports.

4. Remove protective cap and connect recovery/recharging station RED hose to high-side service port (Figure 1, Item 3) on high-side line (Figure 1, Item 4).

HEATING VENTILATING AND AIR CONDITIONING (HVAC) SERVICE/RECHARGE PROCEDURE - (CONTINUED)

- Open high- and low-side hose valves near service ports by turning knobs clockwise.

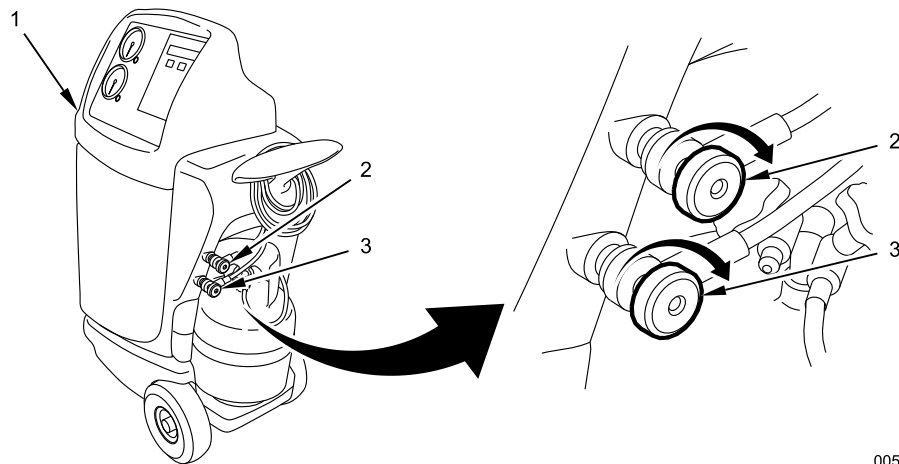

Figure 2. Recovery/Recharging Station.

- Open both valves on recovery/recharging tank.
- Open HIGH (Figure 2, Item 2) and LOW (Figure 2, Item 3) valves on recovery/recharging station (Figure 2, Item 1).

NOTE

It may be necessary to repeat the recovery procedure a second time to remove all of the refrigerant.

- Select RECOVER mode with mode selector on control panel of recovery/recharging station (Figure 2, Item 1) and press START/ENTER.
- When both gauges read zero, recovery is complete. Record amount of refrigerant and oil recovered.

NOTE

If more than 2 oz of PAG oil was recovered, this indicates that the system was overcharged with PAG oil.

- Press START/ENTER again to repeat the recovery cycle. This is necessary to remove all refrigerant from the system. Add together amounts recovered from each recovery cycle to get total refrigerant and total oil recovered.

NOTE

If refrigerant lines are being replaced, disconnect recovery/recharging station lines from vehicle service ports.

END OF TASK

HEATING VENTILATING AND AIR CONDITIONING (HVAC) SERVICE/RECHARGE PROCEDURE - (CONTINUED)

EVACUATION AND RECHARGE PROCEDURE

1. Before evacuating the A/C system, ensure the following actions have been performed when necessary:
 - All necessary repairs have been completed.
 - If compressor had internal damage or contamination was found anywhere in the system, ensure system has been properly flushed and filter/drier and receiver/drier have been replaced. Replacement of filter/drier and receiver/drier is necessary to remove all contaminants from the system.
 - Ensure PAG 46 oil is used on O-ring seals.
 - Ensure PAG 46 oil is used in A/C components when necessary.
 - Ensure all A/C fittings are tightened securely.
2. Connect recovery/recharging station BLUE hose to low-side service port (Figure 3, Item 1) on low side line (Figure 3, Item 2).

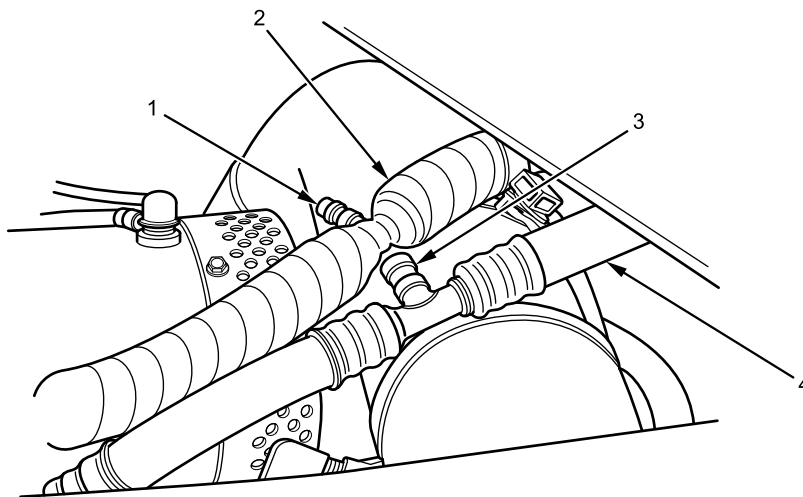

B235203225

Figure 3. HVAC Service Ports.

3. Connect recovery/recharging station RED hose to high-side service port (Figure 3, Item 3) on high side line (Figure 3, Item 4).
4. Open high- and low-side valves near service ports by turning knobs clockwise.
5. Open HIGH (Figure 4, Item 2) and LOW (Figure 4, Item 3) valves on recovery/recharging station (Figure 4, Item 1).

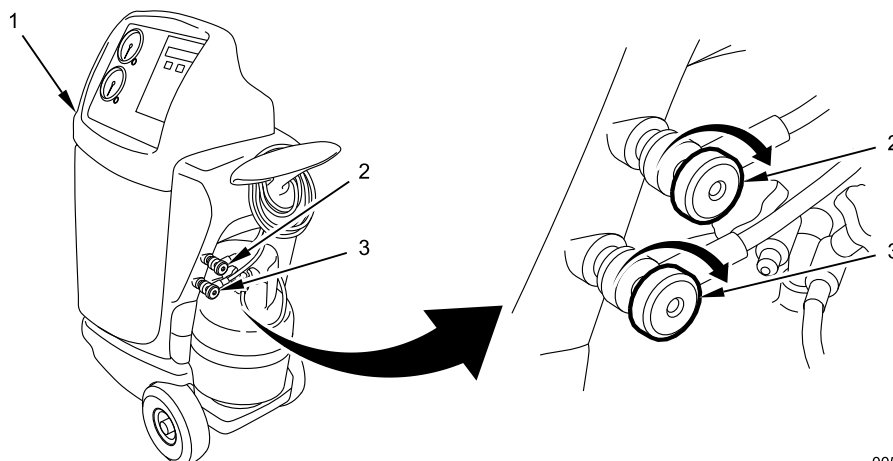

005316

Figure 4. Recovery/Recharging Station.

HEATING VENTILATING AND AIR CONDITIONING (HVAC) SERVICE/RECHARGE PROCEDURE - (CONTINUED)**NOTE**

Allow 30 minutes of vacuum time to remove all moisture from system. Longer vacuum times may be necessary depending on humidity and how long the A/C lines were open for maintenance.

6. Select VACUUM mode with mode selector on dash of recovery/recharging station (Figure 4, Item 1) and press START. Evacuation is complete when low-side pressure gauge reads -27 psi (-186 kPa) or lower for 30 minutes or longer.
7. Close HIGH (Figure 4, Item 2) and LOW (Figure 4, Item 3) valves on recovery/recharging station (Figure 4, Item 1) and turn off vacuum mode.

NOTE

If no leak is found, continue with this procedure. If a leak is found, refer to appropriate work package for repairs.

8. Let system stand for 10-15 minutes and observe low-side pressure gauge for loss of vacuum that could indicate a leak.
9. Refer to the recovery/recharging station user guide for instructions on injecting PAG oil into the system. Set recovery/recharging station (Figure 4, Item 1) to inject an amount of PAG oil equal to amount removed from HVAC system.

NOTE

If a complete recovery has not been performed, do not add 6.0 lbs 12 oz of R-134a refrigerant. Add refrigerant only as needed to achieve the operating pressures indicated by Table 1, R134a Refrigerant Temperature vs Pressure, or chart on the recovery/recharging station. Use Table 1 only when engine has been turned off for more than 30 minutes. Measure refrigerant temperature by positioning probe on A/C line next to service port used to obtain pressure reading. Ensure underhood temperature is accounted for. Underhood temperature can affect pressure reading.

10. Set recovery/recharging station (Figure 4, Item 1) to charge the system with 6.0 lbs, 12 oz of R-134a refrigerant.
11. Open valve on recovery/recharging tank.
12. Open LOW valve (Figure 4, Item 3) on recovery/recharging station (Figure 4, Item 1) to CLOSED.
13. Open HIGH valve (Figure 4, Item 2) on recovery/recharging station (Figure 4, Item 1) to OPEN.
14. Press CHARGE button on recovery/recharging station (Figure 4, Item 1) to start charging procedure.

NOTE

If the HVAC system will not accept all of the refrigerant through the high-side service fitting, perform the following procedure:

- a. Close HIGH valve (Figure 4, Item 2) and open LOW valve (Figure 4, Item 3) on recovery/recharging station (Figure 4, Item 1).
- b. Turn LSS switch on, with COOL mode selected and RA blower speed set to maximum speed.
- c. Start the engine.
- d. Press CHARGE button on recovery/recharging station (Figure 4, Item 1) to restart the charging procedure if necessary.

HEATING VENTILATING AND AIR CONDITIONING (HVAC) SERVICE/RECHARGE PROCEDURE - (CONTINUED)

15. When HVAC system is fully charged, close HIGH (Figure 5, Item 2) and LOW (Figure 5, Item 3) valves on recovery/recharging station (Figure 5, Item 1) and, if necessary, turn engine off.

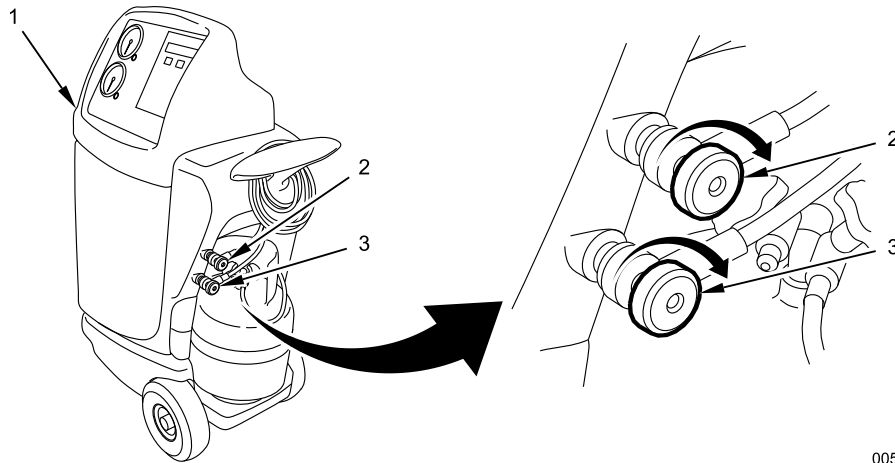

005316

Figure 5. Recovery/Recharging Station.

16. Perform HVAC system operating test procedures before disconnecting recovery/recharging station (Figure 5, Item 1) from A/C system.
 17. Turn engine off.
 18. Close high- and low-side valves located at service ports by turning knobs counterclockwise.

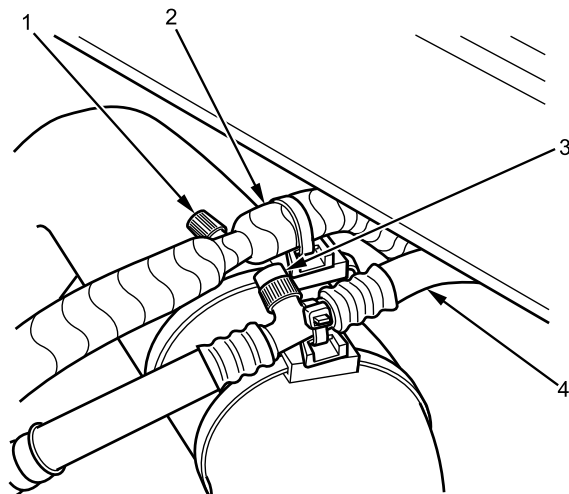

B235201427

Figure 6. HVAC Service Ports.

19. Disconnect BLUE quick-connect fitting from low-side service port on low side line (Figure 6, Item 2) and install protective cap (Figure 6, Item 1).
 20. Disconnect RED quick-connect fitting from high-side service port on high side line (Figure 6, Item 4) and install protective cap (Figure 6, Item 3).

NOTE

Vehicles are filled with PAG oil that incorporates Ultra-Violet (UV) dye during the manufacturing process. UV light may be helpful in locating refrigerant leaks.

HEATING VENTILATING AND AIR CONDITIONING (HVAC) SERVICE/RECHARGE PROCEDURE - (CONTINUED)

21. Check all A/C components and connections for leaks with refrigerant leak detector. Repair leaks as necessary. Refer to appropriate repair procedure.

Table 1. R134a Refrigerant Temperature vs Pressure.

R134a REFRIGERANT TEMPERATURE °F (°C)	R134a REFRIGERANT PRESSURE psi (kPa)
50°F (10°C)	45.5 psi (313.7 kPa)
60°F (15.5°C)	57.4 psi (395.7 kPa)
70°F (21.1°C)	71.1 psi (490.2 kPa)
80°F (26.6°C)	86.7 psi (597.7 kPa)
90°F (32.2°C)	104.3 psi (719.1 kPa)
100°F (37.7°C)	124.2 psi (856.3 kPa)
110°F (43.3°C)	146.4 psi (1,009.3 kPa)
120°F (48.8°C)	171.2 psi (1,180.3 kPa)
130°F (54.4°C)	198.7 psi (1,369.9 kPa)
140°F (60.0°C)	229.2 psi (1,580.2 kPa)
150°F (65.5°C)	262.9 psi (1,812.6 kPa)

END OF TASK

FOLLOW-ON MAINTENANCE

1. Close and secure engine hood (TM 9-2355-106-10).
2. Remove wheel chocks (TM 9-2355-106-10).

END OF TASK

END OF WORK PACKAGE

FIELD MAINTENANCE
HEATING VENTILATING AND AIR CONDITIONING (HVAC) COMPRESSOR REMOVAL AND INSTALLATION

INITIAL SETUP:**Tools and Special Tools**

General Mechanic's Tool Kit (GMTK)
 (WP 0795, Item 37)
 Wrench, torque, click, ratcheting, 15-75 lb-ft, 3/8-inch
 drive (WP 0795, Item 145)
 Measure, liquid, 2 qt (WP 0795, Item 71)
 Cap and Plug Set (WP 0795, Item 23)
 Gloves (WP 0795, Item 38)

TM 9-2355-106-23P

WP 0786

WP 0782

Equipment Condition

Parking brake set (TM 9-2355-106-10)
 Transmission set in NEUTRAL (N) (TM
 9-2355-106-10)
 Engine off (TM 9-2355-106-10)
 MAIN POWER switch OFF (TM 9-2355-106-10)
 Wheels chocked (TM 9-2355-106-10)
 Engine hood open and secured (TM 9-2355-106-10)
 Heating Ventilating and Air Conditioning (HVAC)
 system evacuated and discharged (WP 0707)
 Air conditioning (A/C) belt removed (WP 0244)

Materials/Parts

Faceshield, industrial ((WP 0794, Item 16))
 Lubricating oil (WP 0794, Item 31)
 O-ring (WP 0796, Item 34)
 O-ring (WP 0796, Item 37)
 Tubing (WP 0794, Item 56)

References

TM 9-2355-106-10

HEATING VENTILATING AND AIR CONDITIONING (HVAC) COMPRESSOR REMOVAL AND INSTALLATION - (CONTINUED)

WARNING

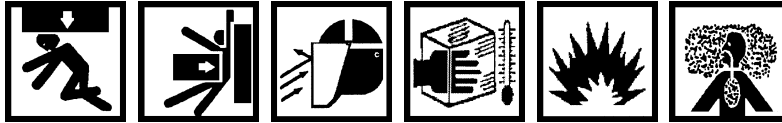

Engine hood is extremely heavy and requires two-person lift. Ensure that there is adequate space in front of the vehicle to open hood completely without pinning or pinching personnel between hood and any other structure. Use extreme care when working under hood and make sure it is properly supported. Failure to comply may result in serious injury or death to personnel.

The temperature of liquid refrigerant is -20°F (-29°C). Wear full face shield, protective rubberized gloves, and protective clothing when working with refrigerant. If refrigerant contacts skin, remove all contaminated clothing. Treat skin as though it were frostbitten or frozen and seek immediate medical attention. If refrigerant contacts eyes, do not rub them. Flush eyes with cold water for at least 15 minutes to gradually increase temperature above freezing point. Seek immediate medical attention. Failure to comply may result in serious injury or death to personnel.

Do not expose refrigerant containers, empty or full, to open flames or temperatures above 125°F (52°C). Do not discard empty containers where they may be subject to heat from a trash burner; containers may explode. Failure to comply may result in damage to equipment and serious injury or death to personnel.

R-134a refrigerant must not be mixed with air and then pressurized. When mixed with large quantities of air and pressurized, R-134a becomes combustible. Failure to comply may result in damage to equipment and environment, and serious injury or death to personnel.

Federal and state laws require that refrigerant be recovered and recycled. Refrigerant must be recovered from system with authorized recommended equipment before any work can be performed on unit. Always use approved recycling equipment to prevent accidental discharge. Failure to comply may result in damage to equipment and environment, and serious injury or death to personnel.

Refrigerant evaporates very quickly and may displace oxygen in surrounding work area, especially in a small or enclosed area. This can cause suffocation or brain damage. If leak occurs, avoid breathing refrigerant vapor and thoroughly ventilate area before continuing service. If personnel breathe refrigerant vapors, obtain immediate medical assistance. Failure to comply may result in serious injury or death to personnel.

Do not install or remove air-conditioning testing or charging equipment while engine is running. Wait 30 seconds after engine shutdown to allow high side and low side pressures to equalize. Failure to comply may result in damage to equipment and environment, and serious injury or death to personnel.

Refrigerant becomes a poisonous gas in the presence of heat. Do not smoke or allow any type of flame in immediate area while servicing air conditioning system. Never weld, solder, steam clean, or use excessive heat on any part of the air conditioning system while charged/pressurized. Failure to comply may result in damage to equipment and serious injury or death to personnel.

HEATING VENTILATING AND AIR CONDITIONING (HVAC) COMPRESSOR REMOVAL AND INSTALLATION - (CONTINUED)

Do not check compressor oil level when HVAC system is charged with refrigerant. Never open the high side hand valve of the manifold gauge set while HVAC system is operating. If hot, high pressure refrigerant is forced through gauge to refrigerant supply cylinder, which could rupture. Do not disconnect HVAC lines from compressor. Release of refrigerant may cause damage to equipment or environment and serious injury or death to personnel.

Do not use parts other than those specified for the system being serviced. Failure to comply may result in damage to equipment and serious injury or death to personnel.

Accidental or intentional introduction of liquid contaminants into the environment is a violation of state, federal, and military regulations. Store, install, and dispose of containers in accordance with standard operating procedures. Refer to Army Petroleum, Oil, and Lubricants (POL) (para. 1-8) for information concerning storage, use, and disposal of liquid contaminants. Failure to comply may result in damage to environment and serious injury or death to personnel.

CAUTION

If valve for electronic vacuum gauge is open during system charging, excess pressure may damage electronic vacuum gauge.

When charging air-conditioning system, keep refrigerant tank upright. If tank is not in upright position, liquid refrigerant may enter system and cause compressor damage.

Overcharging system will result in excessively high head pressures during operation and may damage compressor.

REMOVAL

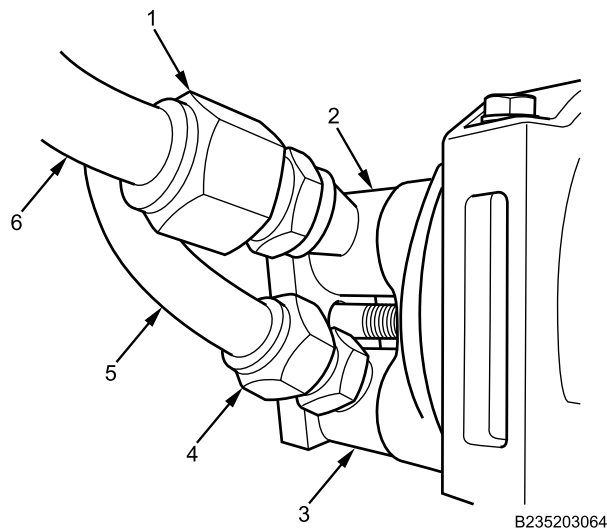

Figure 1. HVAC Hoses At Compressor.

1. Remove heatshrink tubing from both HVAC hose ends (Figure 1, Item 5 and 6).
2. Loosen nuts (Figure 1, Item 1 and 4) and remove both HVAC hoses (Figure 1, Item 5 and 6) from HVAC hose adapters (Figure 1, Item 2 and 3).
3. Remove and discard two O-rings from end of HVAC hoses (Figure 1, Item 5 and 6).
4. Cap and plug ends of HVAC hoses (Figure 1, Item 1 and 4) to prevent contamination.

HEATING VENTILATING AND AIR CONDITIONING (HVAC) COMPRESSOR REMOVAL AND INSTALLATION - (CONTINUED)

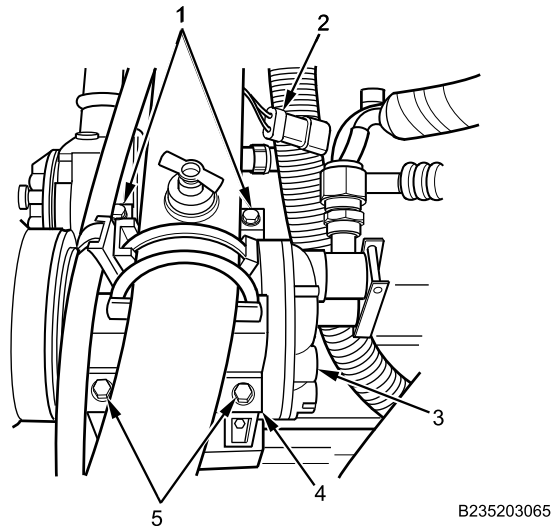

Figure 2. HVAC Compressor.

5. Disconnect compressor clutch wiring connector (Figure 2, Item 2).
6. Remove two bolts (Figure 2, Item 1) from HVAC compressor (Figure 2, Item 3).

CAUTION

Do not drop or turn HVAC compressor upside down for longer than 30 seconds. Failure to comply may result in damage to HVAC compressor.

7. Remove two bolts (Figure 2, Item 5), bracket (Figure 2, Item 4), and HVAC compressor (Figure 2, Item 3) from engine.
8. If replacing HVAC compressor (Figure 2, Item 3), drain oil from old HVAC compressor into small container.

END OF TASK

INSTALLATION

CAUTION

Debris must be removed from HVAC system. If debris cannot be removed, contaminated components must be replaced. Failure to comply may cause damage to equipment.

1. If replacing HVAC compressor, drain oil from new HVAC compressor. Add clean PAG oil equal to amount drained from old HVAC compressor plus 1 ounce to new HVAC compressor.
2. Position HVAC compressor (Figure 3, Item 3) on engine and surrounding brackets (Figure 3, Item 4).

HEATING VENTILATING AND AIR CONDITIONING (HVAC) COMPRESSOR REMOVAL AND INSTALLATION - (CONTINUED)

Figure 3. HVAC Compressor.

3. Install bracket (Figure 3, Item 4) and HVAC compressor (Figure 3, Item 3) on engine with two bolts (Figure 3, Item 5) and finger-tighten.
4. Install two bolts (Figure 3, Item 1) on HVAC compressor (Figure 3, Item 3) and finger-tighten.
5. Torque four bolts (Figure 3, Item 1 and 5) to 16-24 lb-ft (22-33 N•m).
6. Connect HVAC compressor clutch wiring (Figure 3, Item 2).

HEATING VENTILATING AND AIR CONDITIONING (HVAC) COMPRESSOR REMOVAL AND INSTALLATION - (CONTINUED)

7. Remove cap and plug from ends of two HVAC hoses (Figure 4, Item 5 and 6).

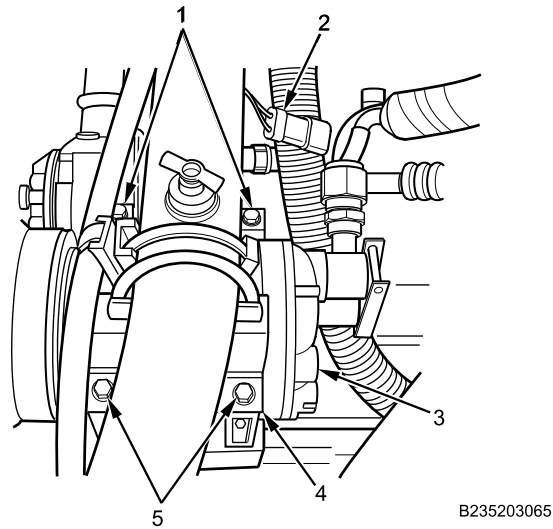
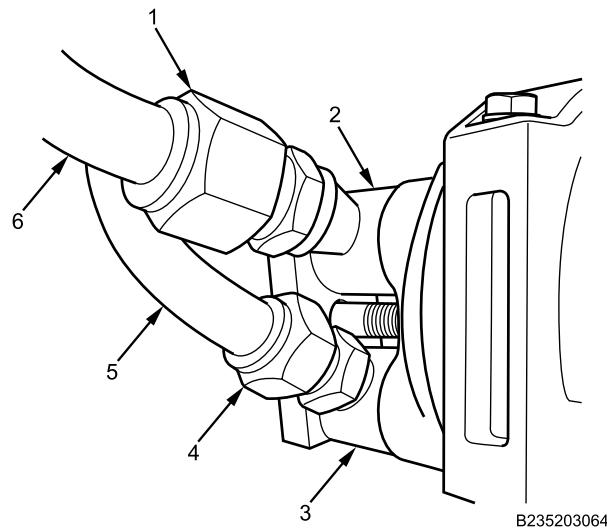

Figure 4. HVAC Hoses At Compressor.

8. Apply PAG oil to two new O-rings and install O-rings on HVAC hose ends (Figure 4, Item 5 and 6).
 9. Slide heatshrink tubing over two HVAC hose ends (Figure 4, Item 5 and 6) and position away from fittings.
 10. Install two HVAC hoses (Figure 4, Item 5 and 6) on HVAC hose adapters (Figure 4, Item 2 and 3).
 11. Tighten nuts (Figure 4, Item 1 and 4) securely.

WARNING



Never use open flame to apply heat to heatshrink tubing. Allow heatshrink tubing to cool before handling. Failure to comply may result in serious injury to personnel.

12. Position heatshrink tubing around HVAC hoses (Figure 4, Item 5 and 6) and fittings and apply heat to heatshrink tubing until secure over hoses and fittings.

END OF TASK

HEATING VENTILATING AND AIR CONDITIONING (HVAC) COMPRESSOR REMOVAL AND INSTALLATION - (CONTINUED)**FOLLOW-ON MAINTENANCE**

1. Install A/C belt (WP 0244).
2. Evacuate and recharge HVAC system (WP 0707).
3. Turn MAIN POWER switch on (TM 9-2355-106-10).
4. Start engine (TM 9-2355-106-10).
5. Verify correct HVAC system operation (TM 9-2355-106-10).
6. Turn engine off (TM 9-2355-106-10).
7. Inspect for HVAC system leaks (TM 9-2355-106-10).
8. Turn MAIN POWER switch off (TM 9-2355-106-10).
9. Close and secure engine hood (TM 9-2355-106-10).
10. Remove wheel chocks (TM 9-2355-106-10).

END OF TASK**END OF WORK PACKAGE**

FIELD MAINTENANCE**HEATING VENTILATING AND AIR CONDITIONING (HVAC) EVAPORATOR INLET HOSE REMOVAL AND INSTALLATION**

INITIAL SETUP:**Tools and Special Tools**

General Mechanic's Tool Kit (GMTK)
(WP 0795, Item 37)
Refrigeration Ordnance Service Tool Kit
(WP 0795, Item 85)
Measure, liquid, 2 qt (WP 0795, Item 71)
Gun, air (WP 0795, Item 43)

TM 9-2355-106-23P

WP 0786

WP 0782

Materials/Parts

Lubricating oil (WP 0794, Item 31)
Tape (WP 0794, Item 51)
Tubing (WP 0794, Item 56)
O-ring - (2) (WP 0796, Item 34)
Cable lock strap - (4) (WP 0796, Item 134)

Equipment Condition

Parking brake set (TM 9-2355-106-10)
Transmission set in NEUTRAL (N) (TM
9-2355-106-10)
Engine off (TM 9-2355-106-10)
MAIN POWER switch off (TM 9-2355-106-10)
Wheels chocked (TM 9-2355-106-10)
Engine hood open and secured (TM 9-2355-106-10)
HVAC system evacuated and discharged (WP 0707)

ReferencesTM 9-2355-106-10

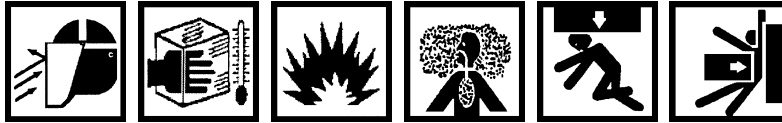
HEATING VENTILATING AND AIR CONDITIONING (HVAC) EVAPORATOR INLET HOSE REMOVAL AND INSTALLATION - (CONTINUED)**WARNING**

The temperature of liquid refrigerant is -20°F (-29°C). Wear full face shield, protective rubberized gloves, and protective clothing when working with refrigerant. If refrigerant contacts skin, remove all contaminated clothing. Treat skin as though it were frostbitten or frozen and seek immediate medical attention. If refrigerant contacts eyes, do not rub them. Flush eyes with cold water for at least 15 minutes to gradually increase temperature above freezing point. Seek immediate medical attention. Failure to comply may result in serious injury or death to personnel.

Do not expose refrigerant containers, empty or full, to open flames or temperatures above 125°F (52°C). Do not discard empty containers where they may be subject to heat from a trash burner; containers may explode. Failure to comply may result in damage to equipment and serious injury or death to personnel.

R-134a refrigerant must not be mixed with air and then pressurized. When mixed with large quantities of air and pressurized, R-134a becomes combustible. Failure to comply may result in damage to equipment and environment, and serious injury or death to personnel.

Federal and state laws require that refrigerant be recovered and recycled. Refrigerant must be recovered from system with authorized recommended equipment before any work can be performed on unit. Always use approved recycling equipment to prevent accidental discharge. Failure to comply may result in damage to equipment and environment, and serious injury or death to personnel.

Refrigerant evaporates very quickly and may displace oxygen in surrounding work area, especially in a small or enclosed area. This can cause suffocation or brain damage. If leak occurs, avoid breathing refrigerant vapor and thoroughly ventilate area before continuing service. If personnel breathe refrigerant vapors, obtain immediate medical assistance. Failure to comply may result in serious injury or death to personnel.

Do not install or remove air-conditioning testing or charging equipment while engine is running. Wait 30 seconds after engine shutdown to allow high side and low side pressures to equalize. Failure to comply may result in damage to equipment and environment, and serious injury or death to personnel.

Refrigerant becomes a poisonous gas in the presence of heat. Do not smoke or allow any type of flame in immediate area while servicing air conditioning system. Never weld, solder, steam clean, or use excessive heat on any part of the air conditioning system while charged/pressurized. Failure to comply may result in damage to equipment and serious injury or death to personnel.

Do not check compressor oil level when HVAC system is charged with refrigerant. Never open the high side hand valve of the manifold gauge set while HVAC system is operating. If hot, high pressure refrigerant is forced through gauge to refrigerant supply cylinder, which could rupture. Do not disconnect HVAC lines from compressor. Release of refrigerant may cause damage to equipment or environment and serious injury or death to personnel.

Do not use parts other than those specified for the system being serviced. Failure to comply may result in damage to equipment and serious injury or death to personnel.

HEATING VENTILATING AND AIR CONDITIONING (HVAC) EVAPORATOR INLET HOSE REMOVAL AND INSTALLATION - (CONTINUED)

Accidental or intentional introduction of liquid contaminants into the environment is a violation of state, federal, and military regulations. Store, install, and dispose of containers in accordance with standard operating procedures. Refer to Army Petroleum, Oil, and Lubricants (POL) (para. 1-8) for information concerning storage, use, and disposal of liquid contaminants. Failure to comply may result in damage to environment and serious injury or death to personnel.

Engine hood is extremely heavy and requires two-person lift. Ensure that there is adequate space in front of the vehicle to open hood completely without pinning or pinching personnel between hood and any other structure. Use extreme care when working under hood and make sure it is properly supported. Failure to comply may result in serious injury or death to personnel.

REMOVAL

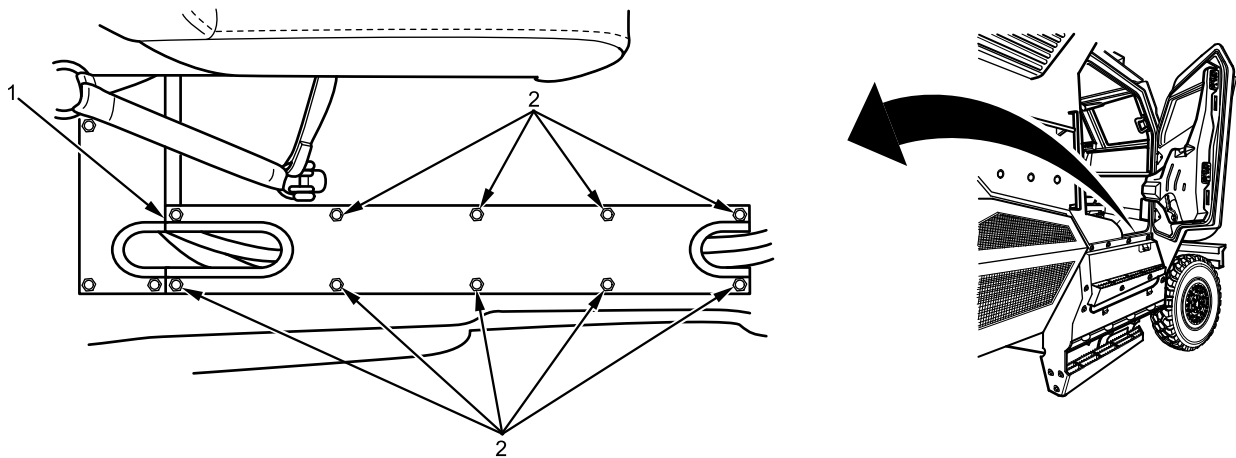

B235210596

Figure 1. Right Main Duct Cover.

1. Remove 10 bolts (Figure 1, Item 2) from right main duct cover (Figure 1, Item 1).
2. Remove right main duct cover (Figure 1, Item 1).

HEATING VENTILATING AND AIR CONDITIONING (HVAC) EVAPORATOR INLET HOSE REMOVAL AND INSTALLATION - (CONTINUED)

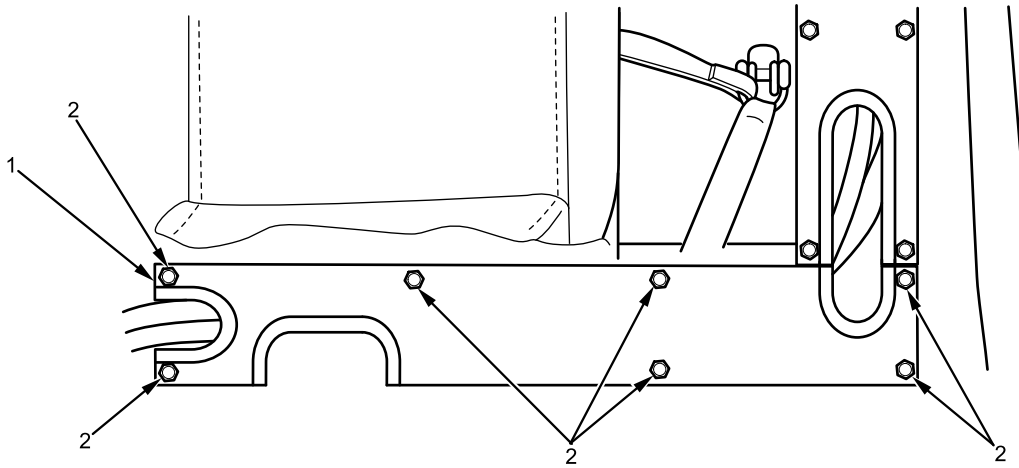

B235201542

Figure 2. Rear Electricity Duct.

3. Remove seven bolts (Figure 2, Item 2) from rear electricity duct cover (Figure 2, Item 1).
4. Remove rear electricity duct cover (Figure 2, Item 1).

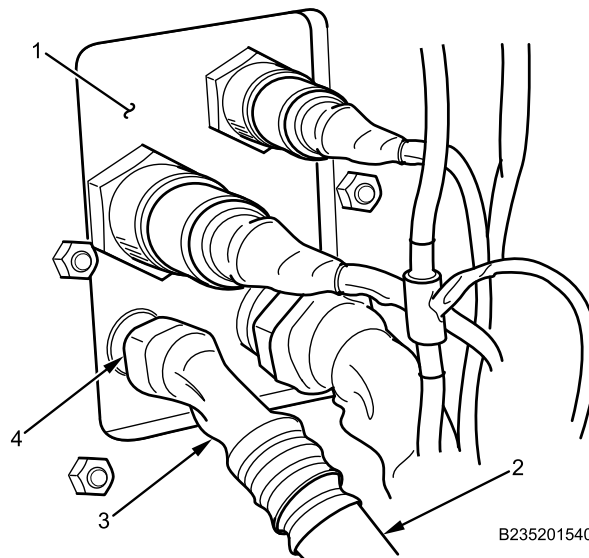

B235201540

Figure 3. Evaporator Inlet Hose at Penetration Dust Plate.

5. Remove heatshrink tubing (Figure 3, Item 3) from evaporator inlet hose (Figure 3, Item 2) at penetration dust plate (Figure 3, Item 1).
6. Disconnect evaporator inlet hose fitting (Figure 3, Item 4) from penetration dust plate (Figure 3, Item 1).

HEATING VENTILATING AND AIR CONDITIONING (HVAC) EVAPORATOR INLET HOSE REMOVAL AND INSTALLATION - (CONTINUED)

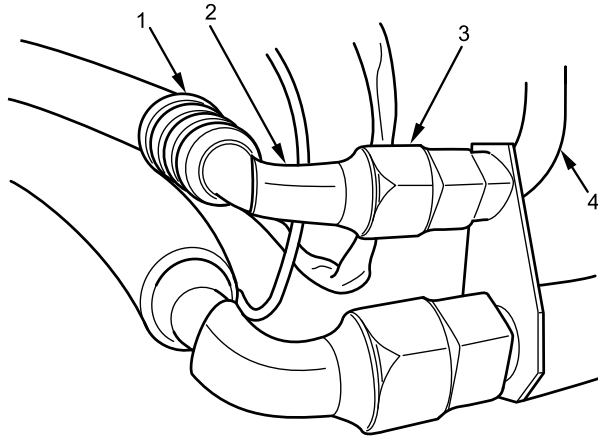

B235201539

Figure 4. Evaporator Inlet Hose at Evaporator.

7. Remove heatshrink tubing (Figure 4, Item 2) from evaporator inlet hose (Figure 4, Item 1) at evaporator inlet (Figure 4, Item 4).
8. Disconnect evaporator inlet hose fitting (Figure 4, Item 3), and remove evaporator inlet hose (Figure 4, Item 1) from evaporator inlet (Figure 4, Item 4).
9. Remove evaporator inlet hose (Figure 4, Item 1).
10. Remove and discard cable ties as necessary.
11. Drain Polyalkylene Glycol (PAG) oil from hose into measure cup.

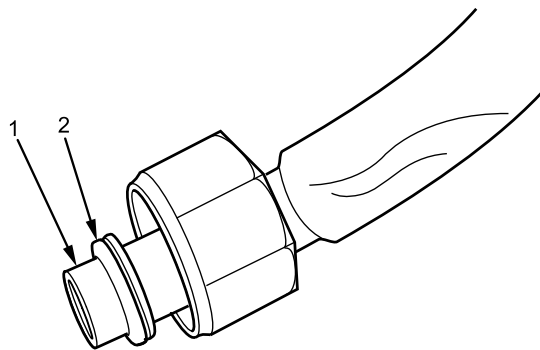

B235203067

Figure 5. HVAC Hose End with O-Ring Installed.

12. Remove O-ring (Figure 5, Item 2) from each end of evaporator inlet hose (Figure 5, Item 1). Discard O-rings.

END OF TASK

HEATING VENTILATING AND AIR CONDITIONING (HVAC) EVAPORATOR INLET HOSE REMOVAL AND INSTALLATION - (CONTINUED)

INSTALLATION

1. Position 3-inch length of 1.5-inch diameter heatshrink tubing on each end of evaporator inlet hose.

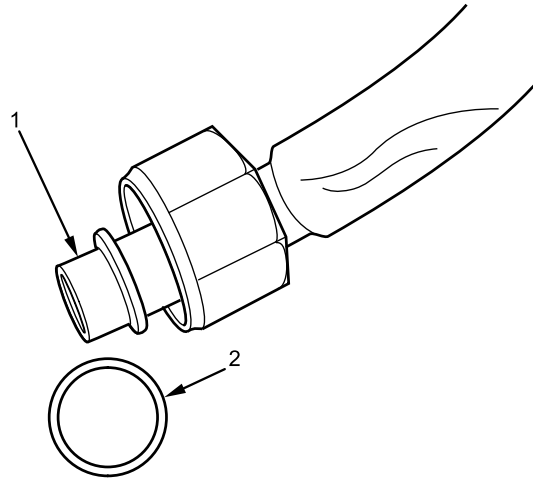

B235203066

Figure 6. HVAC Hose End with O-Ring.

2. Coat new O-rings (Figure 6, Item 2) with PAG oil and install one O-ring on each end of evaporator inlet hose (Figure 6, Item 1).

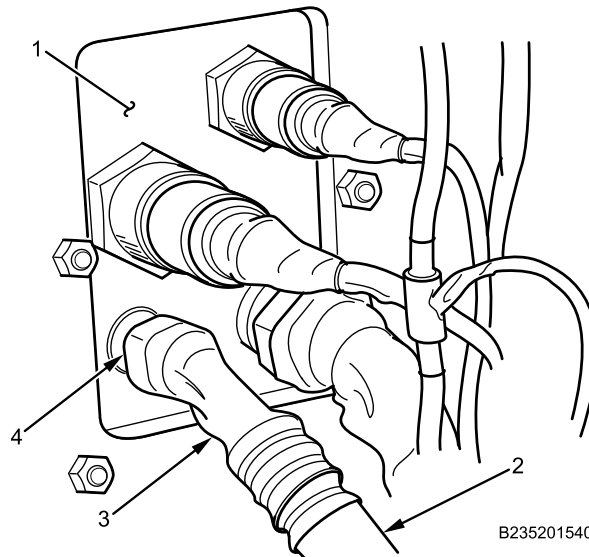

B235201540

Figure 7. Evaporator Inlet Hose at Penetration Dust Plate.

NOTE

End of hose with 45-degree bend is installed at penetration dust plate. End of hose with 90-degree bend is installed at evaporator.

3. Connect evaporator inlet hose (Figure 7, Item 2) to penetration dust plate (Figure 7, Item 1) with fitting (Figure 7, Item 4) and finger-tighten.
4. Add clean PAG oil, equal to amount of oil drained from hose, to other end of hose.

HEATING VENTILATING AND AIR CONDITIONING (HVAC) EVAPORATOR INLET HOSE REMOVAL AND INSTALLATION - (CONTINUED)

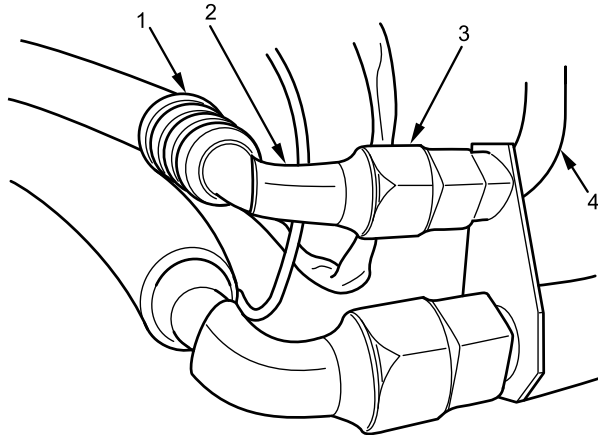

B235201539

Figure 8. Evaporator Inlet Hose at Evaporator.

5. Connect evaporator inlet hose (Figure 8, Item 1) to evaporator inlet (Figure 8, Item 4) with fitting (Figure 8, Item 3) and finger-tighten.
6. Tighten fitting on each end of evaporator inlet hose securely.

WARNING



Never use open flame to apply heat to heatshrink tubing. Allow heatshrink tubing to cool before handling. Failure to comply may result in serious injury to personnel.

7. Apply heat to heatshrink tubing (Figure 8, Item 2)(Figure 7, Item 3) until secure over each fitting.
8. Install new cable ties where removed.

HEATING VENTILATING AND AIR CONDITIONING (HVAC) EVAPORATOR INLET HOSE REMOVAL AND INSTALLATION - (CONTINUED)

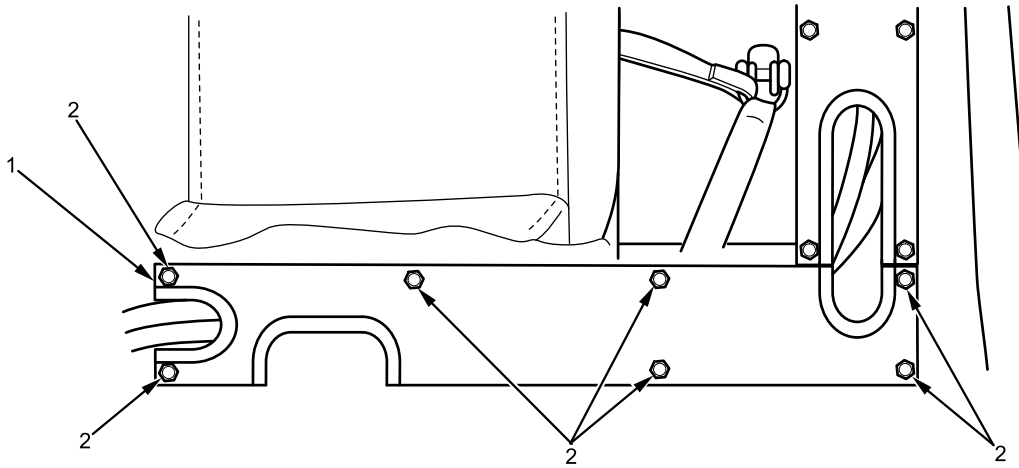

B235201542

Figure 9. Rear Electricity Duct.

9. Install rear electricity duct cover (Figure 9, Item 1) with seven bolts (Figure 9, Item 2) and tighten securely.

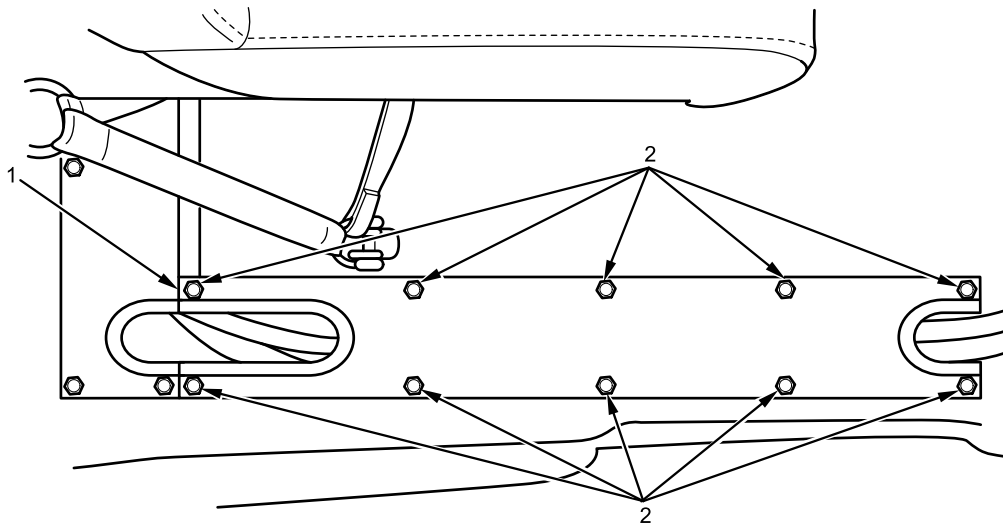

B235201541

Figure 10. Right Main Duct Cover.

10. Install right main duct cover (Figure 10, Item 1) with 10 bolts (Figure 10, Item 2) and tighten securely.

END OF TASK

FOLLOW-ON MAINTENANCE

1. Evacuate and recharge HVAC system (WP 0707).
2. Close and secure engine hood (TM 9-2355-106-10).
3. Remove wheel chocks (TM 9-2355-106-10).

END OF TASK

END OF WORK PACKAGE

FIELD MAINTENANCE**HEATING VENTILATING AND AIR CONDITIONING (HVAC) EVAPORATOR OUTLET HOSE REMOVAL AND INSTALLATION**

INITIAL SETUP:**Tools and Special Tools**

General Mechanic's Tool Kit (GMTK)
(WP 0795, Item 37)
Refrigeration Ordnance Service Tool Kit
(WP 0795, Item 85)
Pan, drain (WP 0795, Item 75)
Gun, air (WP 0795, Item 43)

TM 9-2355-106-23P

WP 0786

WP 0782

Materials/Parts

Tubing (WP 0794, Item 56)
Lubricating oil (WP 0794, Item 31)
O-ring - (4) (WP 0796, Item 37)
Cable lock strap - (4) (WP 0796, Item 134)

Equipment Condition

Parking brake set (TM 9-2355-106-10)
Transmission set in NEUTRAL (N) (TM
9-2355-106-10)
Engine off (TM 9-2355-106-10)
MAIN POWER switch off (TM 9-2355-106-10)
Wheels chocked (TM 9-2355-106-10)
Engine hood open and secured (TM 9-2355-106-10)
HVAC system evacuated and discharged (WP 0707)
HVAC evaporator inlet hose removed (WP 0709)

ReferencesTM 9-2355-106-10

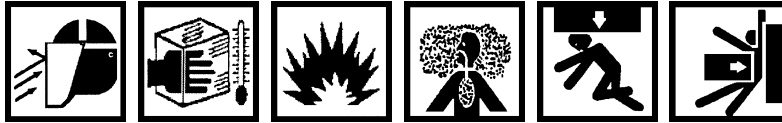
HEATING VENTILATING AND AIR CONDITIONING (HVAC) EVAPORATOR OUTLET HOSE REMOVAL AND INSTALLATION - (CONTINUED)**WARNING**

The temperature of liquid refrigerant is -20°F (-29°C). Wear full face shield, protective rubberized gloves, and protective clothing when working with refrigerant. If refrigerant contacts skin, remove all contaminated clothing. Treat skin as though it were frostbitten or frozen and seek immediate medical attention. If refrigerant contacts eyes, do not rub them. Flush eyes with cold water for at least 15 minutes to gradually increase temperature above freezing point. Seek immediate medical attention. Failure to comply may result in serious injury or death to personnel.

Do not expose refrigerant containers, empty or full, to open flames or temperatures above 125°F (52°C). Do not discard empty containers where they may be subject to heat from a trash burner; containers may explode. Failure to comply may result in damage to equipment and serious injury or death to personnel.

Do not check compressor oil level when HVAC system is charged with refrigerant. Never open the high side hand valve of the manifold gauge set while HVAC system is operating. If hot, high pressure refrigerant is forced through gauge to refrigerant supply cylinder, which could rupture. Do not disconnect HVAC lines from compressor. Release of refrigerant may cause damage to equipment or environment and serious injury or death to personnel.

Do not use parts other than those specified for the system being serviced. Failure to comply may result in damage to equipment and serious injury or death to personnel.

Accidental or intentional introduction of liquid contaminants into the environment is a violation of state, federal, and military regulations. Store, install, and dispose of containers in accordance with standard operating procedures. Refer to Army Petroleum, Oil, and Lubricants (POL) (para. 1-8) for information concerning storage, use, and disposal of liquid contaminants. Failure to comply may result in damage to environment and serious injury or death to personnel.

Engine hood is extremely heavy and requires two-person lift. Ensure that there is adequate space in front of the vehicle to open hood completely without pinning or pinching personnel between hood and any other structure. Use extreme care when working under hood and make sure it is properly supported. Failure to comply may result in serious injury or death to personnel.

R-134a refrigerant must not be mixed with air and then pressurized. When mixed with large quantities of air and pressurized, R-134a becomes combustible. Failure to comply may result in damage to equipment and environment, and serious injury or death to personnel.

Federal and state laws require that refrigerant be recovered and recycled. Refrigerant must be recovered from system with authorized recommended equipment before any work can be performed on unit. Always use approved recycling equipment to prevent accidental discharge. Failure to comply may result in damage to equipment and environment, and serious injury or death to personnel.

Refrigerant evaporates very quickly and may displace oxygen in surrounding work area, especially in a small or enclosed area. This can cause suffocation or brain damage. If leak occurs, avoid breathing refrigerant vapor and thoroughly ventilate area before continuing service. If personnel breathe refrigerant vapors, obtain immediate medical assistance. Failure to comply may result in serious injury or death to personnel.

HEATING VENTILATING AND AIR CONDITIONING (HVAC) EVAPORATOR OUTLET HOSE REMOVAL AND INSTALLATION - (CONTINUED)

Do not install or remove air-conditioning testing or charging equipment while engine is running. Wait 30 seconds after engine shutdown to allow high side and low side pressures to equalize. Failure to comply may result in damage to equipment and environment, and serious injury or death to personnel.

Refrigerant becomes a poisonous gas in the presence of heat. Do not smoke or allow any type of flame in immediate area while servicing air conditioning system. Never weld, solder, steam clean, or use excessive heat on any part of the air conditioning system while charged/pressurized. Failure to comply may result in damage to equipment and serious injury or death to personnel.

REMOVAL

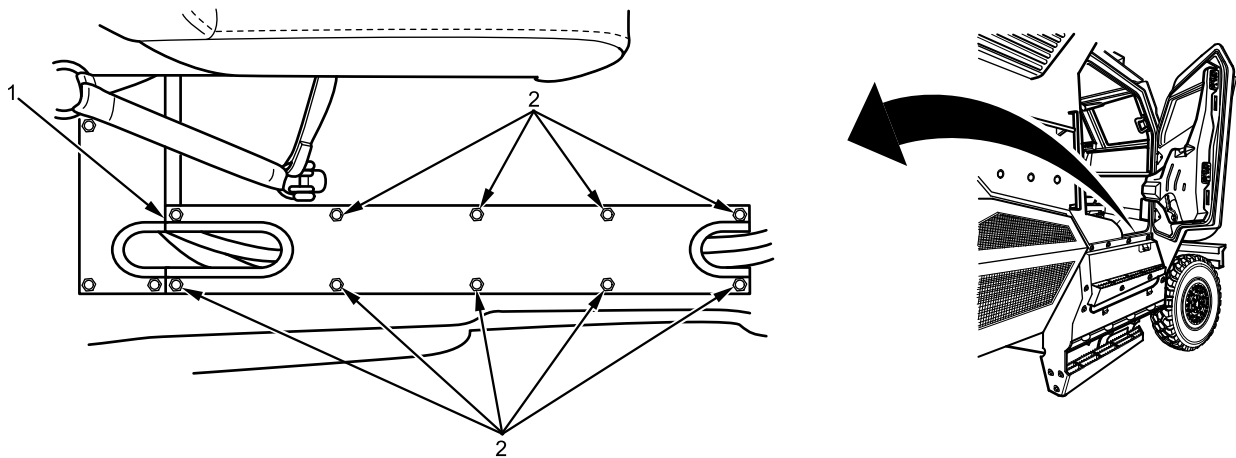

B235210596

Figure 1. Right Main Duct Cover.

1. Remove 10 bolts (Figure 1, Item 2) from right main duct cover (Figure 1, Item 1).
2. Remove right main duct cover (Figure 1, Item 1).

HEATING VENTILATING AND AIR CONDITIONING (HVAC) EVAPORATOR OUTLET HOSE REMOVAL AND INSTALLATION - (CONTINUED)

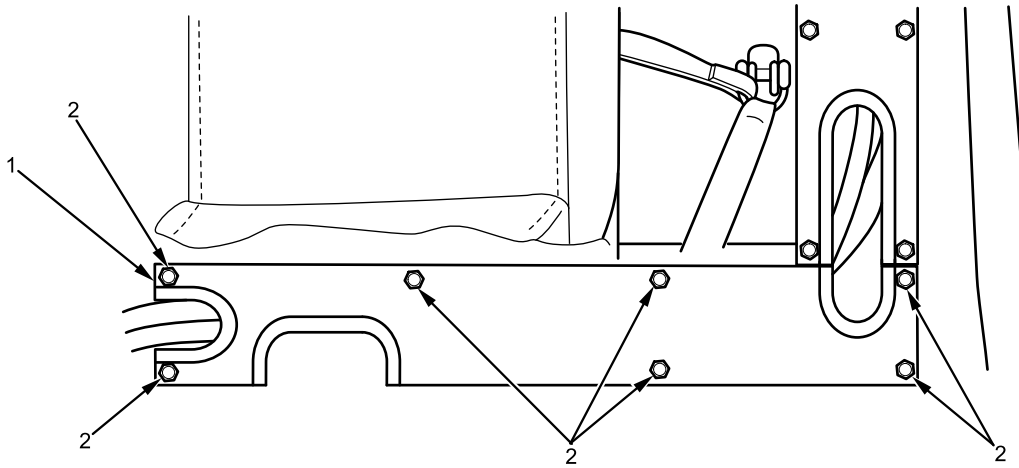

B235201542

Figure 2. Rear Electricity Duct.

3. Remove seven bolts (Figure 2, Item 2) from rear electricity duct cover (Figure 2, Item 1).
4. Remove rear electricity duct cover (Figure 2, Item 1).

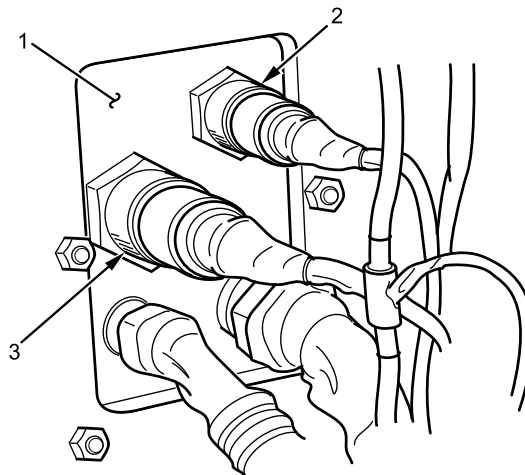

B235201618

Figure 3. Penetration Dust Plate.

5. Remove two harness connectors (Figure 3, Item 2 and 3) from penetration dust plate (Figure 3, Item 1) and position harnesses aside.

HEATING VENTILATING AND AIR CONDITIONING (HVAC) EVAPORATOR OUTLET HOSE REMOVAL AND INSTALLATION - (CONTINUED)

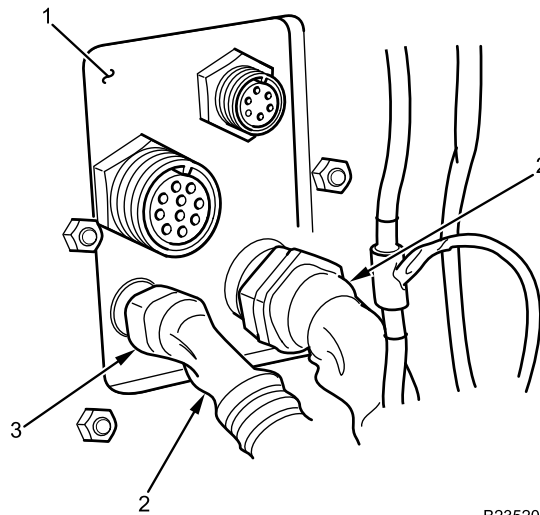

Figure 4. Penetration Dust Plate.

6. Remove heatshrink tubing from evaporator inlet and outlet hoses (Figure 4, Item 2) at penetration dust plate (Figure 4, Item 1).
7. Disconnect evaporator inlet hose fitting (Figure 4, Item 3) from penetration dust plate (Figure 4, Item 1) and position fitting aside.

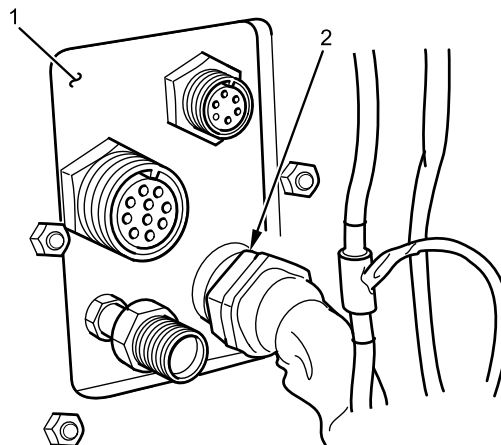
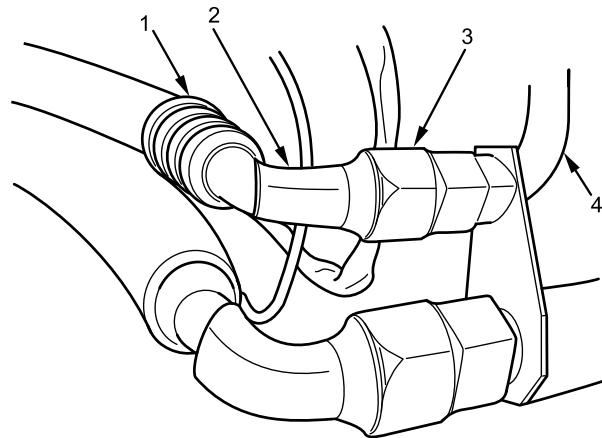

Figure 5. Penetration Dust Plate.

8. Disconnect evaporator outlet hose fitting (Figure 5, Item 2) from penetration dust plate (Figure 5, Item 1).

HEATING VENTILATING AND AIR CONDITIONING (HVAC) EVAPORATOR OUTLET HOSE REMOVAL AND INSTALLATION - (CONTINUED)



B235201539

Figure 6. Evaporator Inlet Hose at Evaporator.

9. Remove heatshrink tubing (Figure 6, Item 2) from evaporator inlet hose (Figure 6, Item 1) at evaporator inlet (Figure 6, Item 4).
10. Disconnect evaporator inlet hose fitting (Figure 6, Item 3) and remove evaporator inlet hose (Figure 6, Item 1) from evaporator inlet (Figure 6, Item 4). Position fitting aside.

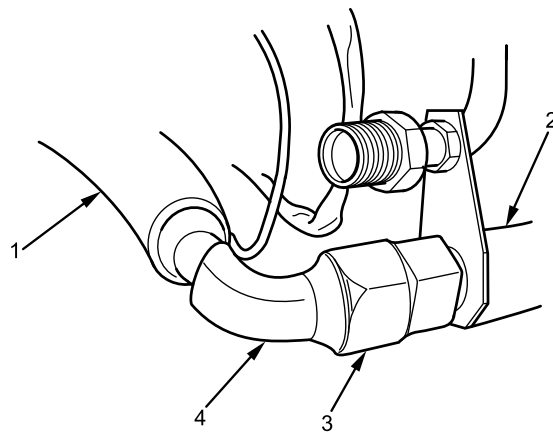

B235203078

Figure 7. Evaporator Outlet Hose at Evaporator.

11. Remove heatshrink tubing (Figure 7, Item 4) from evaporator outlet hose (Figure 7, Item 1) at evaporator outlet (Figure 7, Item 2).
12. Disconnect evaporator outlet hose fitting (Figure 7, Item 3) from evaporator outlet (Figure 7, Item 2).
13. Remove evaporator outlet hose (Figure 7, Item 1) assembly from main duct.
14. Remove and discard cable lock straps as necessary.
15. Drain Polyalkylene Glycol (PAG) oil from hose (Figure 7, Item 1) into drain pan.

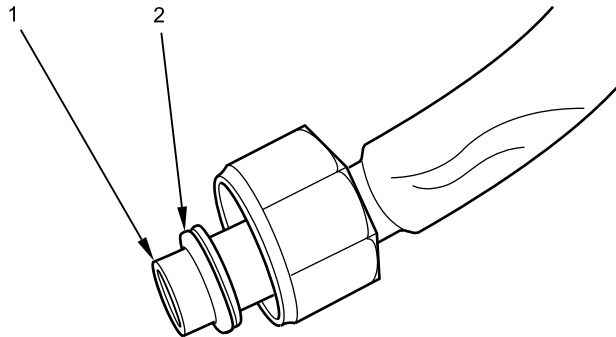
HEATING VENTILATING AND AIR CONDITIONING (HVAC) EVAPORATOR OUTLET HOSE REMOVAL AND INSTALLATION - (CONTINUED)

B235203067

Figure 8. HVAC Hose End with O-Ring Installed.

16. Remove O-ring (Figure 8, Item 2) from each end of evaporator inlet and outlet hoses (Figure 8, Item 1). Discard O-rings.

END OF TASK**INSTALLATION**

1. Position 3-inch length of 1.5-inch diameter heatshrink tubing on each end of evaporator inlet and outlet hoses.
2. Coat new O-rings (Figure 9, Item 2) with PAG oil and install one O-ring on each end of evaporator inlet and outlet hoses (Figure 9, Item 1).

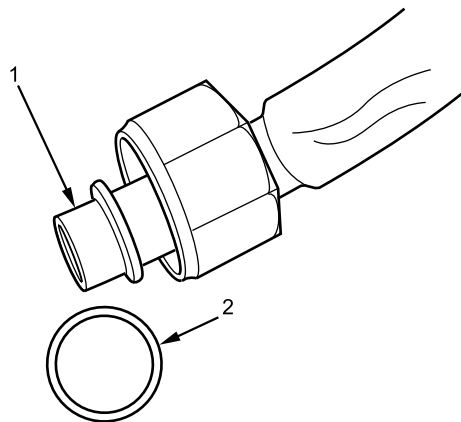

B235203066

Figure 9. HVAC Hose End with O-Ring.

HEATING VENTILATING AND AIR CONDITIONING (HVAC) EVAPORATOR OUTLET HOSE REMOVAL AND INSTALLATION - (CONTINUED)

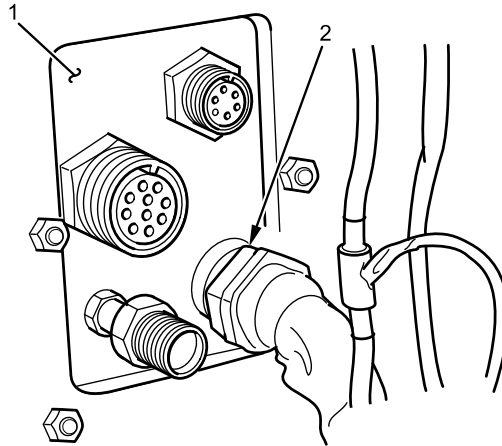

B235203079

Figure 10. Evaporator Outlet Hose at Penetration Dust Plate.

NOTE

End of hose with 45-degree bend is installed at penetration dust plate. End of hose with 90-degree bend is installed at evaporator.

3. Connect evaporator outlet hose fitting (Figure 10, Item 2) to penetration dust plate (Figure 10, Item 1) and finger tighten.
4. Add clean PAG oil, equal to amount of oil drained from evaporator outlet hose, to other end of hose.

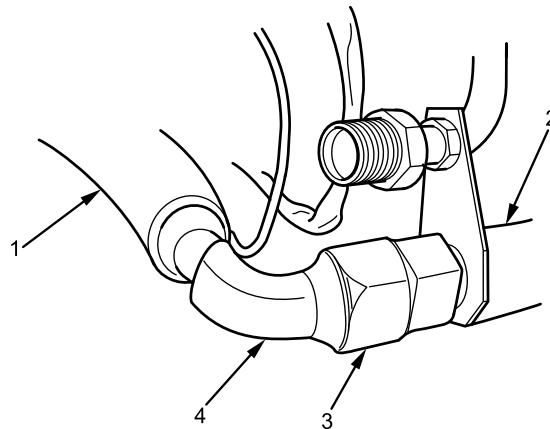

B235203078

Figure 11. Evaporator Outlet Hose at Evaporator.

5. Connect evaporator outlet hose (Figure 11, Item 1) to evaporator outlet (Figure 11, Item 2) and finger tighten.
6. Tighten evaporator outlet hose fittings (Figure 11, Item 2)(Figure 11, Item 3) securely.

HEATING VENTILATING AND AIR CONDITIONING (HVAC) EVAPORATOR OUTLET HOSE REMOVAL AND INSTALLATION - (CONTINUED)

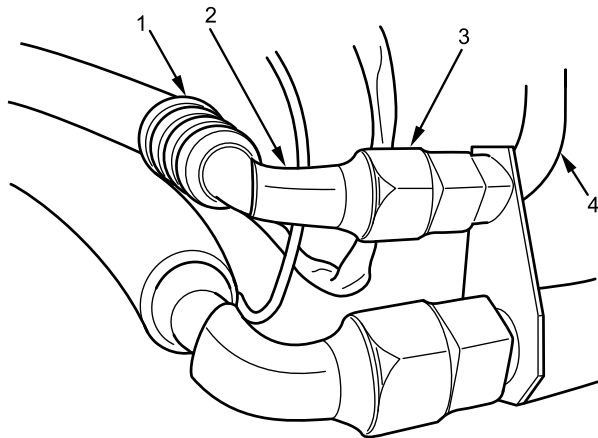

B235201539

Figure 12. Evaporator Inlet Hose at Evaporator.

7. Connect evaporator inlet hose (Figure 12, Item 1) to evaporator inlet (Figure 12, Item 4) with fitting (Figure 12, Item 3) and finger tighten.

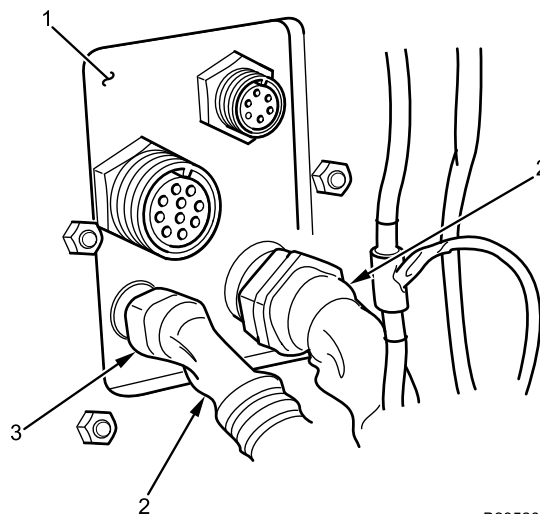

B235203080

Figure 13. Penetration Dust Plate.

8. Connect evaporator inlet hose fitting (Figure 13, Item 3) to penetration dust plate (Figure 13, Item 1).
9. Tighten evaporator inlet hose fittings (Figure 13, Item 3)(Figure 12, Item 3) securely.

HEATING VENTILATING AND AIR CONDITIONING (HVAC) EVAPORATOR OUTLET HOSE REMOVAL AND INSTALLATION - (CONTINUED)

WARNING



Never use open flame to apply heat to heatshrink tubing. Allow heatshrink tubing to cool before handling. Failure to comply may result in serious injury to personnel.

10. Apply heat to heatshrink tubing (Figure 11, Item 4)(Figure 12, Item 2)(Figure 13, Item 2) until secure over each fitting.

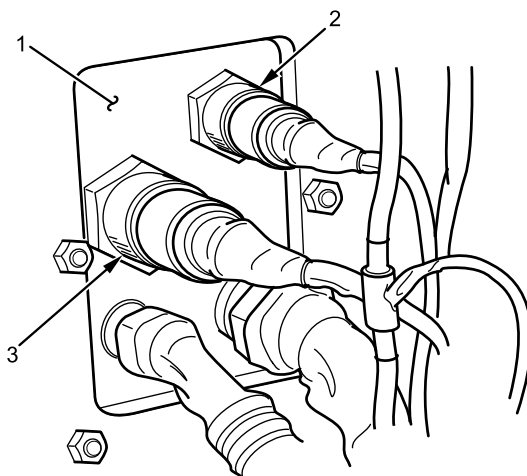

B235201618

Figure 14. Penetration Dust Plate.

11. Connect two harness connectors (Figure 14, Item 2 and 3) to penetration dust plate (Figure 14, Item 1) and tighten securely.
12. Install new cable lock straps where removed.

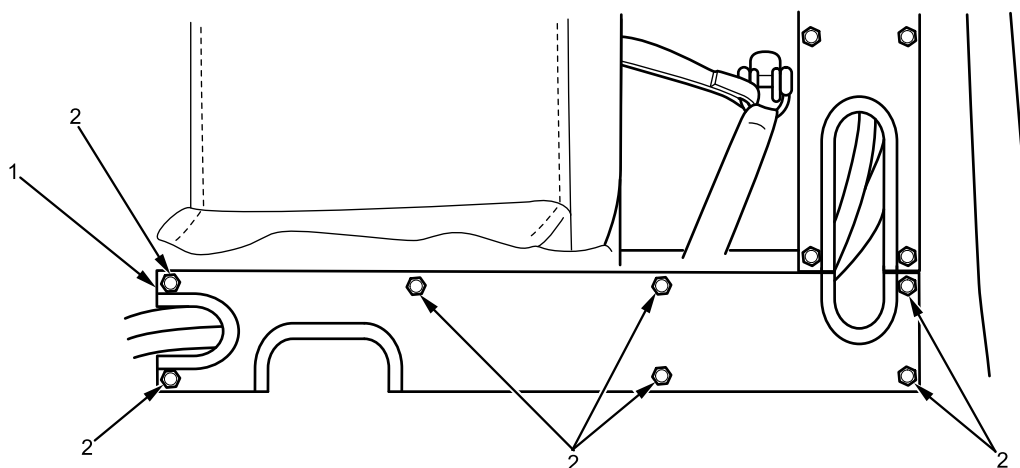

B235201542

Figure 15. Rear HVAC Channel Cover.

13. Install rear channel cover (Figure 15, Item 1) with seven bolts (Figure 15, Item 2) and tighten securely.

HEATING VENTILATING AND AIR CONDITIONING (HVAC) EVAPORATOR OUTLET HOSE REMOVAL AND INSTALLATION - (CONTINUED)

Figure 16. Right HVAC Channel Cover.

14. Install right channel cover (Figure 16, Item 1) with 10 bolts (Figure 16, Item 2) and tighten securely.

END OF TASK**FOLLOW-ON MAINTENANCE**

1. Evacuate and recharge HVAC system (WP 0707).
2. Close and secure engine hood (TM 9-2355-106-10).
3. Remove wheel chocks (TM 9-2355-106-10).

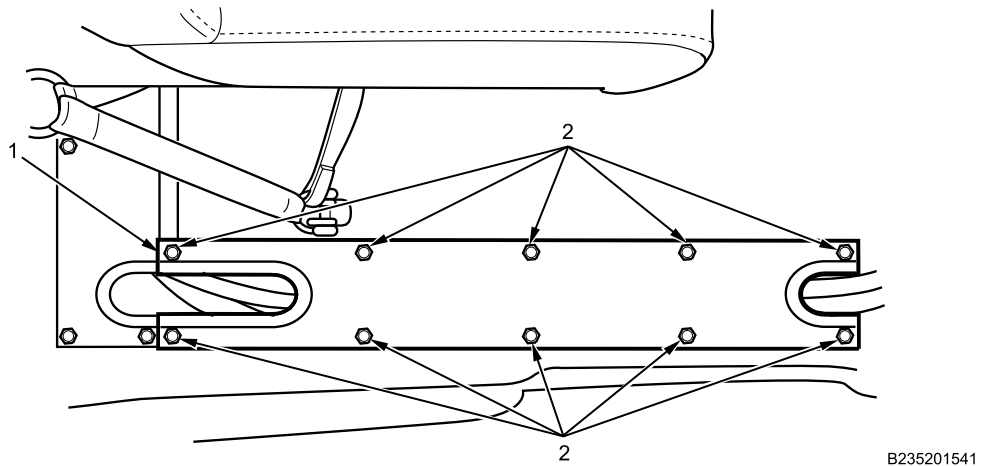
END OF TASK**END OF WORK PACKAGE**

FIELD MAINTENANCE**HEATING VENTILATING AND AIR CONDITIONING (HVAC) FILTER OUTLET HOSE REMOVAL AND INSTALLATION**

INITIAL SETUP:**Tools and Special Tools**

General Mechanic's Tool Kit (GMTK)
(WP 0795, Item 37)
Measure, liquid, 2 qt (WP 0795, Item 71)

TM 9-2355-106-23P
WP 0782

Materials/Parts

Faceshield, industrial (WP 0794, Item 16)
Gloves (WP 0794, Item 19)
Lubricating oil (WP 0794, Item 31)
O-ring - (2) (WP 0796, Item 35)

Equipment Condition

Parking brake set (TM 9-2355-106-10)
Transmission set in NEUTRAL (N) (TM 9-2355-106-10)
Engine off (TM 9-2355-106-10)
MAIN POWER switch off (TM 9-2355-106-10)
Wheels chocked (TM 9-2355-106-10)
Engine hood open and secured (TM 9-2355-106-10)
HVAC system refrigerant recovered (WP 0707)

References

TM 9-2355-106-10

HEATING VENTILATING AND AIR CONDITIONING (HVAC) FILTER OUTLET HOSE REMOVAL AND INSTALLATION - (CONTINUED)

WARNING

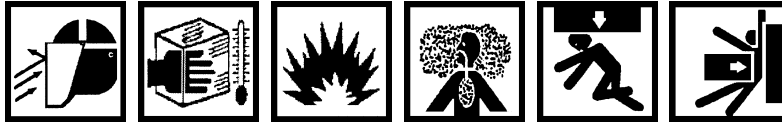

Federal and state laws require that refrigerant be recovered and recycled. Refrigerant must be recovered from system with authorized recommended equipment before any work can be performed on unit. Always use approved recycling equipment to prevent accidental discharge. Failure to comply may result in damage to equipment and environment, and serious injury or death to personnel.

Accidental or intentional introduction of liquid contaminants into the environment is a violation of state, federal, and military regulations. Store, install, and dispose of containers in accordance with standard operating procedures. Refer to Army POL (para. 1-8) for information concerning storage, use, and disposal of liquid contaminants. Failure to comply may result in damage to environment and serious injury or death to personnel.

The temperature of liquid refrigerant is -20°F (-29°C). Wear full face shield, protective rubberized gloves, and protective clothing when working with refrigerant. If refrigerant contacts skin, remove all contaminated clothing. Treat skin as though it were frostbitten or frozen and seek immediate medical attention. If refrigerant contacts eyes, do not rub them. Flush eyes with cold water for at least 15 minutes to gradually increase temperature above freezing point. Seek immediate medical attention. Failure to comply may result in serious injury or death to personnel.

R-134a refrigerant must not be mixed with air and then pressurized. When mixed with large quantities of air and pressurized, R-134a becomes combustible. Failure to comply may result in damage to equipment and environment, and serious injury or death to personnel.

Refrigerant evaporates very quickly and may displace oxygen in surrounding work area, especially in a small or enclosed area. This can cause suffocation or brain damage. If leak occurs, avoid breathing refrigerant vapor and thoroughly ventilate area before continuing service. If personnel breathe refrigerant vapors, obtain immediate medical assistance. Failure to comply may result in serious injury or death to personnel.

Do not install or remove air-conditioning testing or charging equipment while engine is running. Wait 30 seconds after engine shutdown to allow high side and low side pressures to equalize. Failure to comply may result in damage to equipment and environment, and serious injury or death to personnel.

Refrigerant becomes a poisonous gas in the presence of heat. Do not smoke or allow any type of flame in immediate area while servicing air conditioning system. Never weld, solder, steam clean, or use excessive heat on any part of the air conditioning system while charged/pressurized. Failure to comply may result in damage to equipment and serious injury or death to personnel.

Do not check compressor oil level when HVAC system is charged with refrigerant. Never open the high side hand valve of the manifold gauge set while HVAC system is operating. If hot, high pressure refrigerant is forced through gauge to refrigerant supply cylinder, which could rupture. Do not disconnect HVAC lines from compressor. Release of refrigerant may cause damage to equipment or environment and serious injury or death to personnel.

HEATING VENTILATING AND AIR CONDITIONING (HVAC) FILTER OUTLET HOSE REMOVAL AND INSTALLATION - (CONTINUED)

Do not use parts other than those specified for the system being serviced. Failure to comply may result in damage to equipment and serious injury or death to personnel.

Engine hood is extremely heavy and requires two-person lift. Ensure that there is adequate space in front of the vehicle to open hood completely without pinning or pinching personnel between hood and any other structure. Use extreme care when working under hood and make sure it is properly supported. Failure to comply may result in serious injury or death to personnel.

REMOVAL

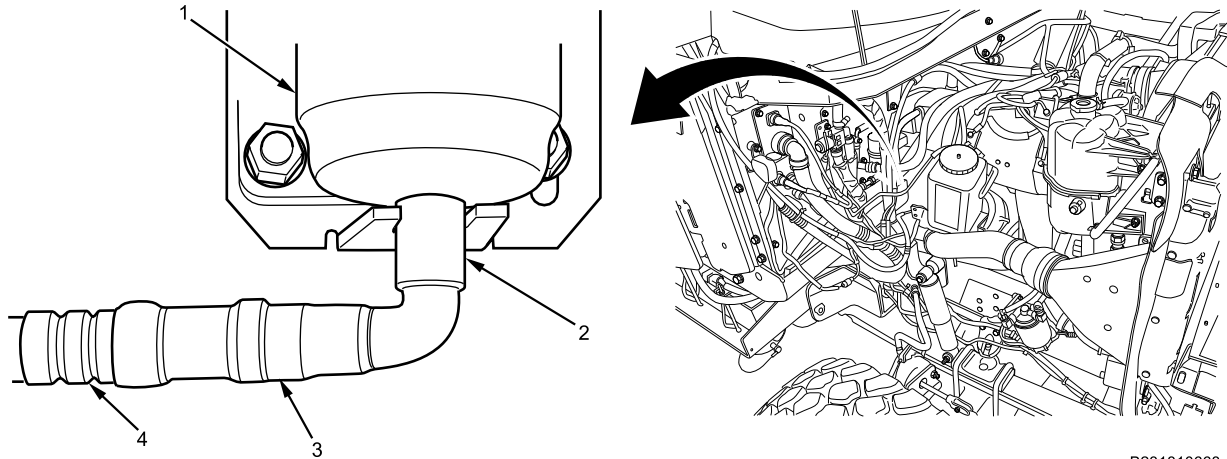

B231810668

Figure 1. HVAC Filter Outlet.

1. Remove shrink tubing (Figure 1, Item 3) from HVAC filter outlet hose (Figure 1, Item 4) at HVAC filter (Figure 1, Item 1).
2. Disconnect HVAC filter outlet hose (Figure 1, Item 4) from HVAC filter outlet (Figure 1, Item 2).

HEATING VENTILATING AND AIR CONDITIONING (HVAC) FILTER OUTLET HOSE REMOVAL AND INSTALLATION - (CONTINUED)

3. Remove shrink tubing (Figure 2, Item 1) from HVAC filter outlet hose (Figure 2, Item 3) at penetration dust plate (Figure 2, Item 2).

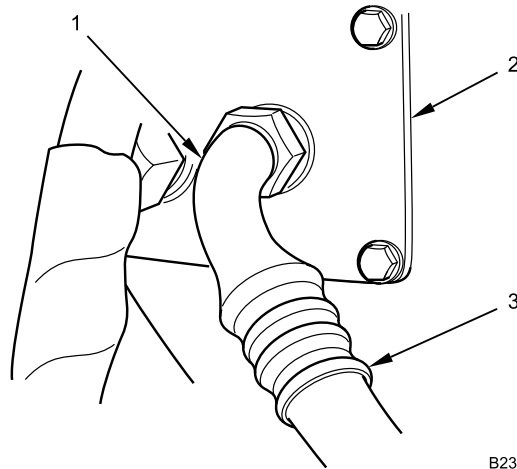

B235201536

Figure 2. HVAC Filter Outlet Hose at Penetration Dust Plate.

4. Disconnect HVAC filter outlet hose (Figure 2, Item 3) from penetration dust plate (Figure 2, Item 2).
5. Remove HVAC filter outlet hose (Figure 2, Item 3).
6. Drain PAG oil from hose (Figure 2, Item 3) into liquid measure.
7. Remove and discard O-rings (Figure 3, Item 2) from both ends of HVAC filter outlet hose (Figure 3, Item 1).

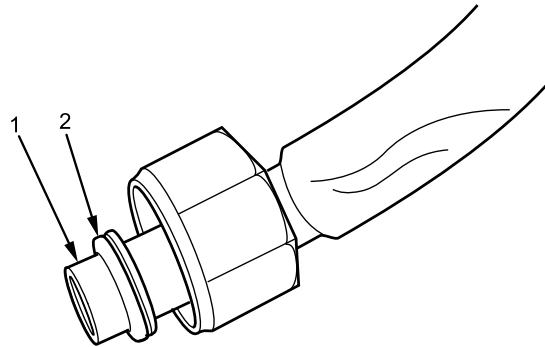

B235203067

Figure 3. HVAC Filter Outlet Hose O-Ring.

END OF TASK

HEATING VENTILATING AND AIR CONDITIONING (HVAC) FILTER OUTLET HOSE REMOVAL AND INSTALLATION - (CONTINUED)

INSTALLATION

1. Coat new O-rings (Figure 4, Item 2) with PAG oil and install one O-ring on each end of HVAC filter outlet hose (Figure 4, Item 1).

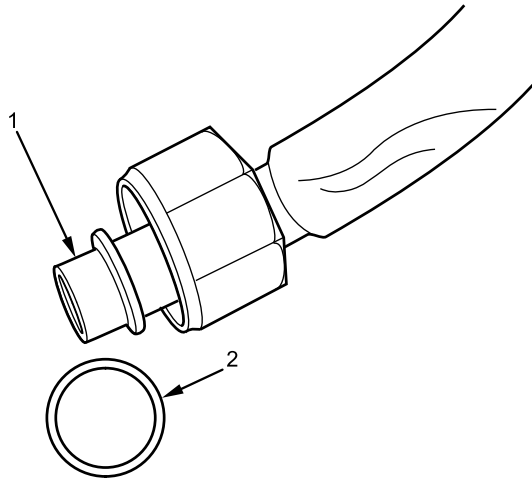

B235203066

Figure 4. HVAC Filter Outlet Hose O-Ring.

2. Connect end of HVAC filter outlet hose (Figure 5, Item 3) to HVAC filter (Figure 5, Item 1) at HVAC filter outlet (Figure 5, Item 2) and finger-tighten.

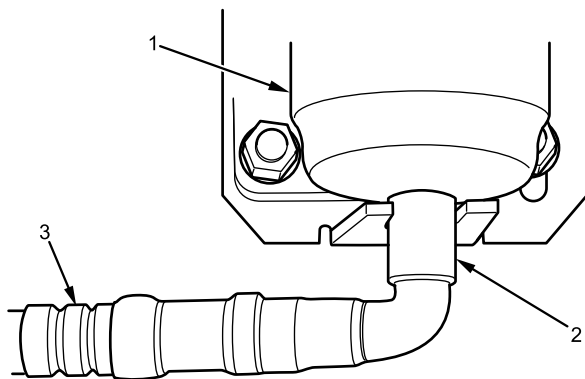

B232210697

Figure 5. HVAC Filter Outlet.

3. Add clean PAG oil, equal to amount of oil drained from hose, to other end of hose.

HEATING VENTILATING AND AIR CONDITIONING (HVAC) FILTER OUTLET HOSE REMOVAL AND INSTALLATION - (CONTINUED)

4. Connect HVAC filter outlet hose (Figure 6, Item 2) on penetration dust plate (Figure 6, Item 1) and finger-tighten.

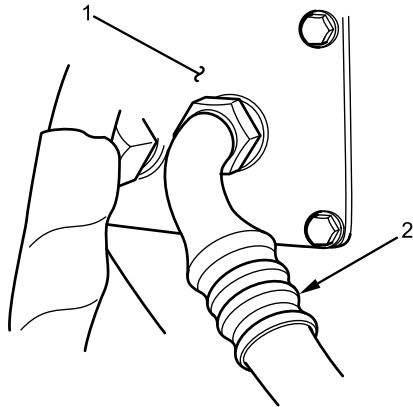

B232210698

Figure 6. HVAC Filter Outlet Hose at Penetration Dust Plate.

5. Tighten fitting on each end of HVAC filter outlet hose (Figure 6, Item 2) securely.

END OF TASK**FOLLOW-ON MAINTENANCE**

1. Evacuate and recharge HVAC system (WP 0707).
2. Close and secure engine hood (TM 9-2355-106-10).
3. Remove wheel chocks (TM 9-2355-106-10).

END OF TASK**END OF WORK PACKAGE**

FIELD MAINTENANCE**HEATING VENTILATING AND AIR CONDITIONING (HVAC) COMPRESSOR SUCTION HOSE REMOVAL
AND INSTALLATION**

INITIAL SETUP:**Tools and Special Tools**

General Mechanic's Tool Kit (GMTK)
(WP 0795, Item 37)
Gloves, rubber (WP 0795, Item 38)
Measure, liquid, 2 qt (WP 0795, Item 71)

Materials/Parts

Faceshield, industrial (WP 0794, Item 16)
Cap and plug set (WP 0794, Item 23)
Lubricating oil (WP 0794, Item 31)
O-ring - (2) (WP 0796, Item 37)
Cable lock strap - (6) (WP 0796, Item 134)

References

TM 9-2355-106-10

TM 9-2355-106-23P

WP 0782

Equipment Condition

Parking brake set (TM 9-2355-106-10)
Transmission set in NEUTRAL (N) (TM
9-2355-106-10)
Engine off (TM 9-2355-106-10)
MAIN POWER switch off (TM 9-2355-106-10)
Wheels chocked (TM 9-2355-106-10)
Engine hood open and secured (TM 9-2355-106-10)
Right side engine armor plate removed (WP 0599)
HVAC low pressure switch removed (WP 0771)

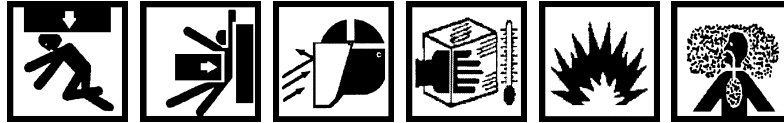
HEATING VENTILATING AND AIR CONDITIONING (HVAC) COMPRESSOR SUCTION HOSE REMOVAL AND INSTALLATION - (CONTINUED)**WARNING**

Federal and state laws require that refrigerant be recovered and recycled. Refrigerant must be recovered from system with authorized recommended equipment before any work can be performed on unit. Always use approved recycling equipment to prevent accidental discharge. Failure to comply may result in damage to equipment and environment, and serious injury or death to personnel.

Do not install or remove air-conditioning testing or charging equipment while engine is running. Wait 30 seconds after engine shutdown to allow high side and low side pressures to equalize. Failure to comply may result in damage to equipment and environment, and serious injury or death to personnel.

Do not use parts other than those specified for the system being serviced. Failure to comply may result in damage to equipment and serious injury or death to personnel.

Engine hood is extremely heavy and requires two-person lift. Ensure that there is adequate space in front of the vehicle to open hood completely without pinning or pinching personnel between hood and any other structure. Use extreme care when working under hood and make sure it is properly supported. Failure to comply may result in serious injury or death to personnel.

The temperature of liquid refrigerant is -20°F (-29°C). Wear full faceshield, protective rubberized gloves, and protective clothing when working with refrigerant. If refrigerant contacts skin, remove all contaminated clothing. Treat skin as though it were frostbitten or frozen and seek immediate medical attention. If refrigerant contacts eyes, do not rub them. Flush eyes with cold water for at least 15 minutes to gradually increase temperature above freezing point. Seek immediate medical attention. Failure to comply may result in serious injury or death to personnel.

HEATING VENTILATING AND AIR CONDITIONING (HVAC) COMPRESSOR SUCTION HOSE REMOVAL AND INSTALLATION - (CONTINUED)

Do not expose refrigerant containers, empty or full, to open flames or temperatures above 125°F (52°C). Do not discard empty containers where they may be subject to heat from a trash burner; containers may explode. Failure to comply may result in damage to equipment and serious injury or death to personnel.

Refrigerant evaporates very quickly and may displace oxygen in surrounding work area, especially in a small or enclosed area. This can cause suffocation or brain damage. If leak occurs, avoid breathing refrigerant vapor and thoroughly ventilate area before continuing service. If personnel breathe refrigerant vapors, obtain immediate medical assistance. Failure to comply may result in serious injury or death to personnel.

Accidental or intentional introduction of liquid contaminants into the environment is a violation of state, federal, and military regulations. Store, install, and dispose of containers in accordance with standard operating procedures. Refer to Army POL (para. 1-8) for information concerning storage, use, and disposal of liquid contaminants. Failure to comply may result in damage to environment and serious injury or death to personnel.

Do not check compressor oil level when HVAC system is charged with refrigerant. Never open the high side hand valve of the manifold gauge set while HVAC system is operating. If hot, high pressure refrigerant is forced through gauge to refrigerant supply cylinder, which could rupture. Do not disconnect HVAC lines from compressor. Release of refrigerant may cause damage to equipment or environment and serious injury or death to personnel.

R-134a refrigerant must not be mixed with air and then pressurized. When mixed with large quantities of air and pressurized, R-134a becomes combustible. Failure to comply may result in damage to equipment and environment, and serious injury or death to personnel.

Refrigerant becomes a poisonous gas in the presence of heat. Do not smoke or allow any type of flame in immediate area while servicing air conditioning system. Never weld, solder, steam clean, or use excessive heat on any part of the air conditioning system while charged/pressurized. Failure to comply may result in damage to equipment and serious injury or death to personnel.

HEATING VENTILATING AND AIR CONDITIONING (HVAC) COMPRESSOR SUCTION HOSE REMOVAL AND INSTALLATION - (CONTINUED)

REMOVAL

CAUTION

Do not allow dirt to contaminate HVAC compressor or suction hose. Failure to comply may result in damage to HVAC components and equipment.

NOTE

Record location of cable lock straps on HVAC compressor suction hose to aid in installation.

Avoid spilling PAG oil from HVAC compressor suction hose to aid in accurate content measurement.

1. Remove heatshrink tubing (Figure 1, Item 1) from HVAC compressor suction hose (Figure 1, Item 2).

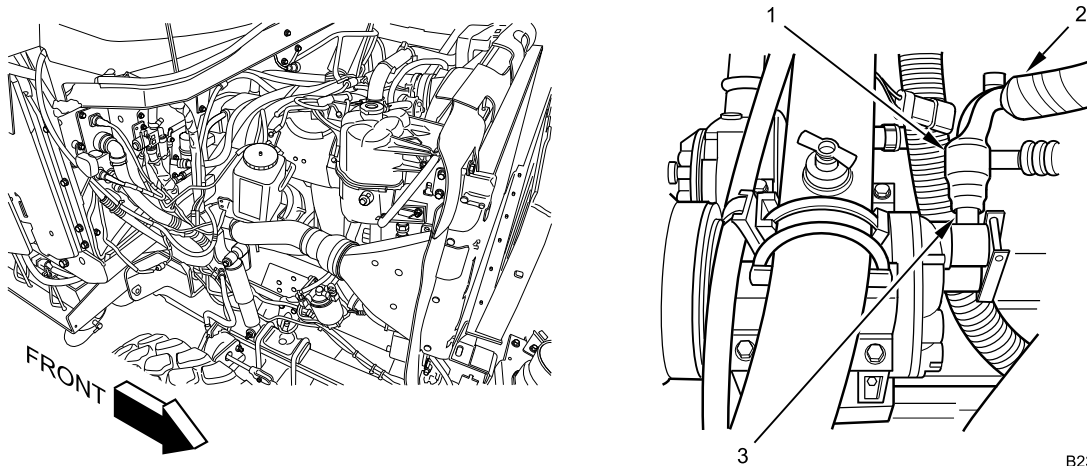

B232210689

Figure 1. HVAC Compressor Suction Hose at Compressor Inlet.

2. Remove and discard cable lock straps from HVAC compressor suction hose (Figure 1, Item 2).
3. Disconnect HVAC compressor suction hose (Figure 1, Item 2) from compressor inlet (Figure 1, Item 3).
4. Cap and plug end of HVAC compressor suction hose (Figure 1, Item 2).

HEATING VENTILATING AND AIR CONDITIONING (HVAC) COMPRESSOR SUCTION HOSE REMOVAL AND INSTALLATION - (CONTINUED)

5. Remove heatshrink tubing (Figure 2, Item 1) from HVAC compressor suction hose (Figure 2, Item 2).

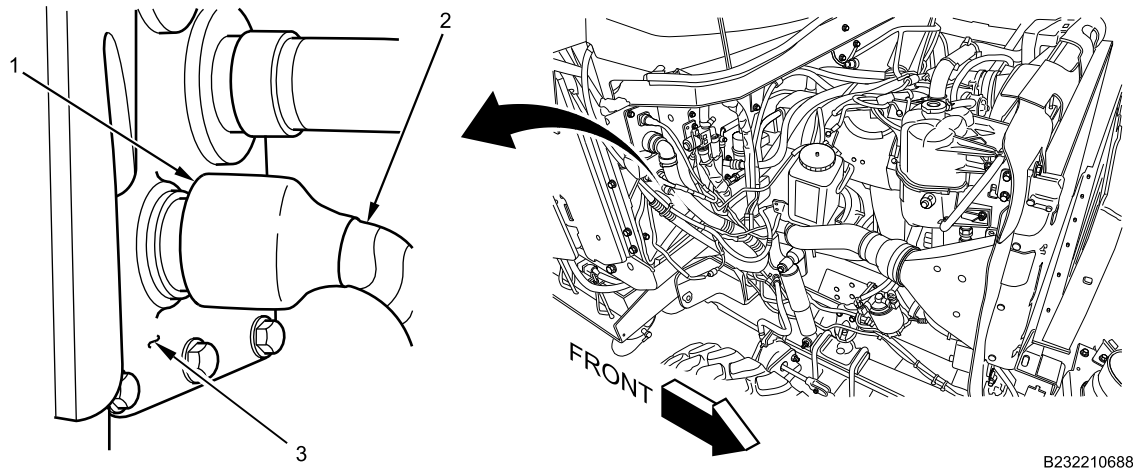

B232210688

Figure 2. HVAC Compressor Suction Hose at Penetration Dust Plate.

6. Disconnect HVAC compressor suction hose from penetration dust plate (Figure 2, Item 3).
7. Remove HVAC compressor suction hose (Figure 2, Item 2).
8. Drain PAG oil from HVAC compressor suction hose (Figure 2, Item 2) into liquid measure.
9. Record amount of PAG oil drained from HVAC compressor suction hose (Figure 2, Item 2) and discard PAG oil.
10. Remove cap and plug from compressor end of HVAC compressor suction hose (Figure 2, Item 2).
11. Remove and discard O-rings (Figure 3, Item 2) from each end of HVAC compressor suction hose (Figure 3, Item 1).

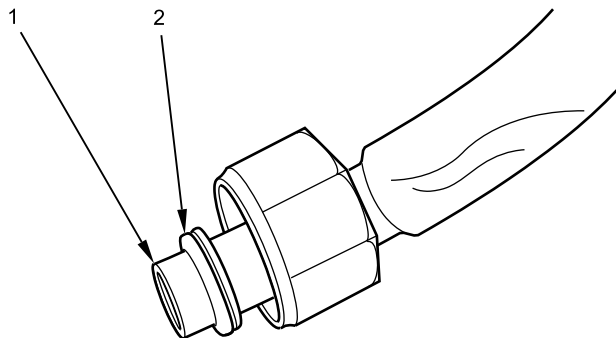

B235203067

Figure 3. O-Rings

END OF TASK

HEATING VENTILATING AND AIR CONDITIONING (HVAC) COMPRESSOR SUCTION HOSE REMOVAL AND INSTALLATION - (CONTINUED)**INSTALLATION**

1. Coat new O-rings (Figure 4, Item 2) with PAG oil and install one O-ring on each end of HVAC compressor suction hose (Figure 4, Item 1).

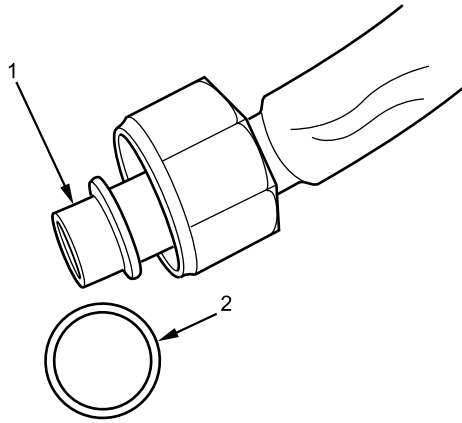

B235203066

Figure 4. O-Ring Installation.

2. Install HVAC compressor suction hose (Figure 5, Item 1) and finger-tighten.

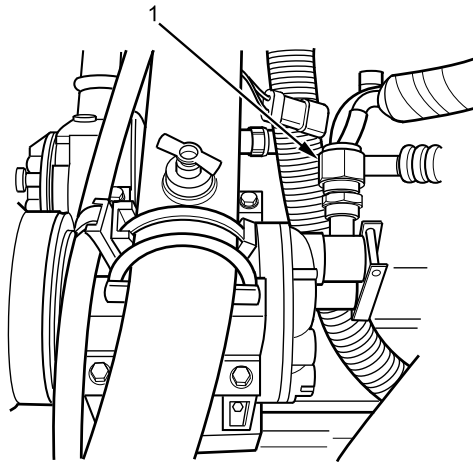

B235201621

Figure 5. Compressor Inlet.

3. Add clean PAG oil, equal to amount drained from hose, to end of HVAC compressor suction hose at penetration dust plate.

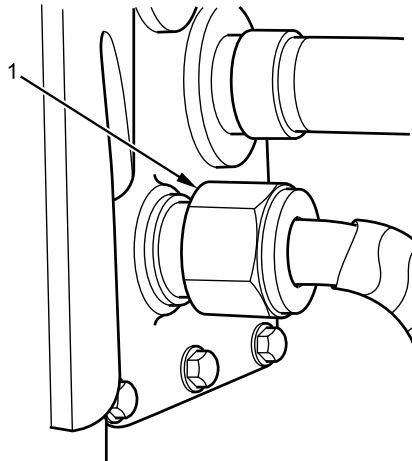
HEATING VENTILATING AND AIR CONDITIONING (HVAC) COMPRESSOR SUCTION HOSE REMOVAL AND INSTALLATION - (CONTINUED)

B235201620

Figure 6. HVAC Compressor Suction Hose at Penetration Dust Plate.

4. Connect HVAC compressor suction hose fitting (Figure 6, Item 1) to penetration dust plate and finger-tighten.
5. Tighten both HVAC compressor suction hose fittings securely.
6. Install new cable lock straps on compressor suction hose as noted in removal.

END OF TASK**FOLLOW-ON MAINTENANCE**

1. Install HVAC low pressure switch (WP 0771).
2. Install right side engine armor plate (WP 0599).
3. Close and secure engine hood (TM 9-2355-106-10).
4. Remove wheel chocks (TM 9-2355-106-10).

END OF TASK**END OF WORK PACKAGE**

FIELD MAINTENANCE
HEATING VENTILATING AND AIR CONDITIONING (HVAC) LEFT-SIDE CONDENSER INLET HOSE REMOVAL AND INSTALLATION

INITIAL SETUP:**Tools and Special Tools**

General Mechanic's Tool Kit (GMTK)
 (WP 0795, Item 37)
 Cap and plug set (WP 0795, Item 23)
 Measure, liquid, 2 qt (WP 0795, Item 71)
 Gloves, rubber (WP 0795, Item 38)

Materials/Parts

Faceshield, industrial (WP 0794, Item 16)
 Lubricating oil (WP 0794, Item 31)
 Tape (WP 0794, Item 51)
 Wire (WP 0794, Item 57)
 O-ring - (2) (WP 0796, Item 35)
 Cable lock strap - (6) (WP 0796, Item 134)

References

TM 9-2355-106-10

TM 9-2355-106-23P

WP 0782

Equipment Condition

Parking brake set (TM 9-2355-106-10)
 Transmission set in NEUTRAL (N) (TM 9-2355-106-10)
 Engine off (TM 9-2355-106-10)
 MAIN POWER switch off (TM 9-2355-106-10)
 Wheels chocked (TM 9-2355-106-10)
 Engine hood open and secured (TM 9-2355-106-10)
 Exterior fuel tank armor door removed (WP 0605)
 Air conditioning (A/C) condenser panel removed (WP 0672)
 Air cleaner housing removed (WP 0257)
 HVAC system refrigerant recovered (WP 0707)
 3-Way valve removed (WP 0727)

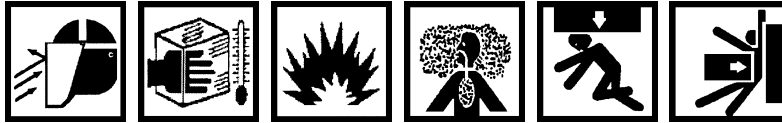
HEATING VENTILATING AND AIR CONDITIONING (HVAC) LEFT-SIDE CONDENSER INLET HOSE REMOVAL AND INSTALLATION - (CONTINUED)**WARNING**

Federal and state laws require that refrigerant be recovered and recycled. Refrigerant must be recovered from system with authorized recommended equipment before any work can be performed on unit. Always use approved recycling equipment to prevent accidental discharge. Failure to comply may result in damage to equipment and environment, and serious injury or death to personnel.

Do not install or remove air-conditioning testing or charging equipment while engine is running. Wait 30 seconds after engine shutdown to allow high side and low side pressures to equalize. Failure to comply may result in damage to equipment and environment, and serious injury or death to personnel.

The temperature of liquid refrigerant is -20°F (-29°C). Wear full faceshield, protective rubberized gloves, and protective clothing when working with refrigerant. If refrigerant contacts skin, remove all contaminated clothing. Treat skin as though it were frostbitten or frozen and seek immediate medical attention. If refrigerant contacts eyes, do not rub them. Flush eyes with cold water for at least 15 minutes to gradually increase temperature above freezing point. Seek immediate medical attention. Failure to comply may result in serious injury or death to personnel.

Do not expose refrigerant containers, empty or full, to open flames or temperatures above 125°F (52°C). Do not discard empty containers where they may be subject to heat from a trash burner; containers may explode. Failure to comply may result in damage to equipment and serious injury or death to personnel.

Engine hood is extremely heavy and requires two-person lift. Ensure that there is adequate space in front of the vehicle to open hood completely without pinning or pinching personnel between hood and any other structure. Use extreme care when working under hood and make sure it is properly supported. Failure to comply may result in serious injury or death to personnel.

HEATING VENTILATING AND AIR CONDITIONING (HVAC) LEFT-SIDE CONDENSER INLET HOSE REMOVAL AND INSTALLATION - (CONTINUED)

R-134a refrigerant must not be mixed with air and then pressurized. When mixed with large quantities of air and pressurized, R-134a becomes combustible. Failure to comply may result in damage to equipment and environment, and serious injury or death to personnel.

Refrigerant evaporates very quickly and may displace oxygen in surrounding work area, especially in a small or enclosed area. This can cause suffocation or brain damage. If leak occurs, avoid breathing refrigerant vapor and thoroughly ventilate area before continuing service. If personnel breathe refrigerant vapors, obtain immediate medical assistance. Failure to comply may result in serious injury or death to personnel.

Refrigerant becomes a poisonous gas in the presence of heat. Do not smoke or allow any type of flame in immediate area while servicing air conditioning system. Never weld, solder, steam clean, or use excessive heat on any part of the air conditioning system while charged/pressurized. Failure to comply may result in damage to equipment and serious injury or death to personnel.

Do not use parts other than those specified for the system being serviced. Failure to comply may result in damage to equipment and serious injury or death to personnel.

Do not check compressor oil level when HVAC system is charged with refrigerant. Never open the high side hand valve of the manifold gauge set while HVAC system is operating. If hot, high pressure refrigerant is forced through gauge to refrigerant supply cylinder, which could rupture. Do not disconnect HVAC lines from compressor. Release of refrigerant may cause damage to equipment or environment and serious injury or death to personnel.

Accidental or intentional introduction of liquid contaminants into the environment is a violation of state, federal, and military regulations. Store, install, and dispose of containers in accordance with standard operating procedures. Refer to Army POL (para. 1-8) for information concerning storage, use, and disposal of liquid contaminants. Failure to comply may result in damage to environment and serious injury or death to personnel.

HEATING VENTILATING AND AIR CONDITIONING (HVAC) LEFT-SIDE CONDENSER INLET HOSE REMOVAL AND INSTALLATION - (CONTINUED)

REMOVAL

NOTE

Record location of cable lock straps before removing condenser inlet hose to aid in installation.

1. Remove heatshrink tubing (Figure 1, Item 2) from condenser inlet hose (Figure 1, Item 3) at tee (Figure 1, Item 1).

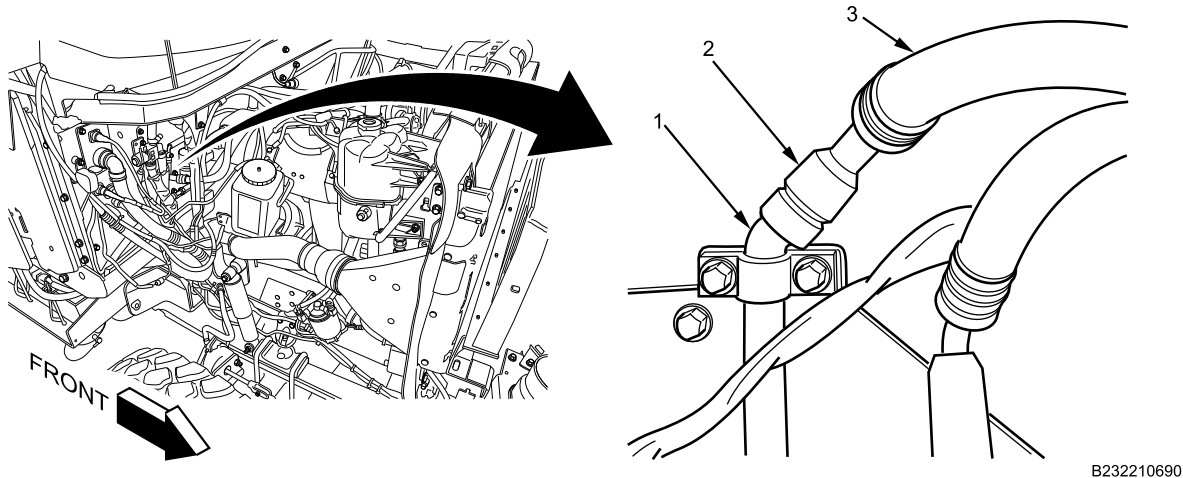

Figure 1. Left HVAC Condenser Hose at Tee.

2. Remove and discard cable lock straps from condenser inlet hose (Figure 1, Item 3).

NOTE

Avoid spilling PAG oil when disconnecting condenser inlet hose

3. Disconnect condenser inlet hose (Figure 1, Item 3) from tee (Figure 1, Item 1).

CAUTION

Ensure cap is securely taped on tee end of condenser inlet hose to avoid contaminating condenser line. Failure to comply may result in damage to HVAC components and equipment.

4. Using tape, securely attach cap (Figure 2, Item 1) to tee end of condenser inlet hose (Figure 2, Item 2).

HEATING VENTILATING AND AIR CONDITIONING (HVAC) LEFT-SIDE CONDENSER INLET HOSE REMOVAL AND INSTALLATION - (CONTINUED)

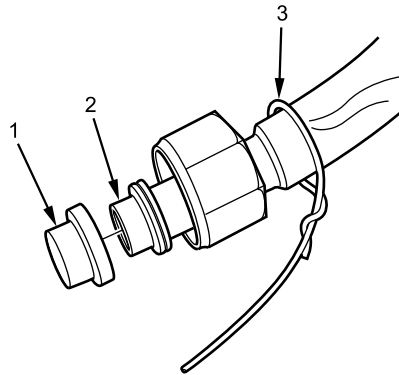

B232210691

Figure 2. Condenser Hose.

5. Securely attach wire (Figure 2, Item 3) to end of condenser inlet hose.
6. Position tee end of condenser inlet hose (Figure 3, Item 1) near left front cab double-floor compartment opening (Figure 3, Item 2).

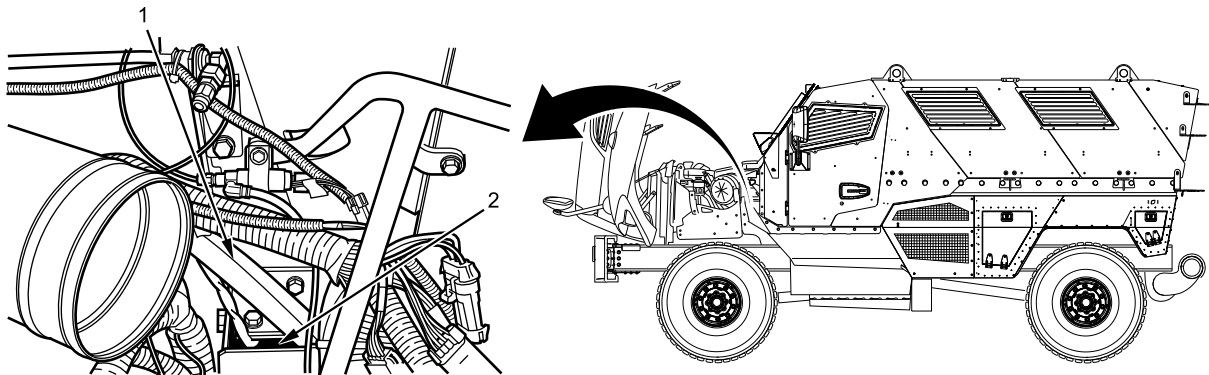

B232210694

Figure 3. Left Front Opening to Cab Double-Floor.

7. Remove heatshrink tubing (Figure 4, Item 2) from condenser inlet hose (Figure 4, Item 1) at condenser (Figure 4, Item 3).

HEATING VENTILATING AND AIR CONDITIONING (HVAC) LEFT-SIDE CONDENSER INLET HOSE REMOVAL AND INSTALLATION - (CONTINUED)

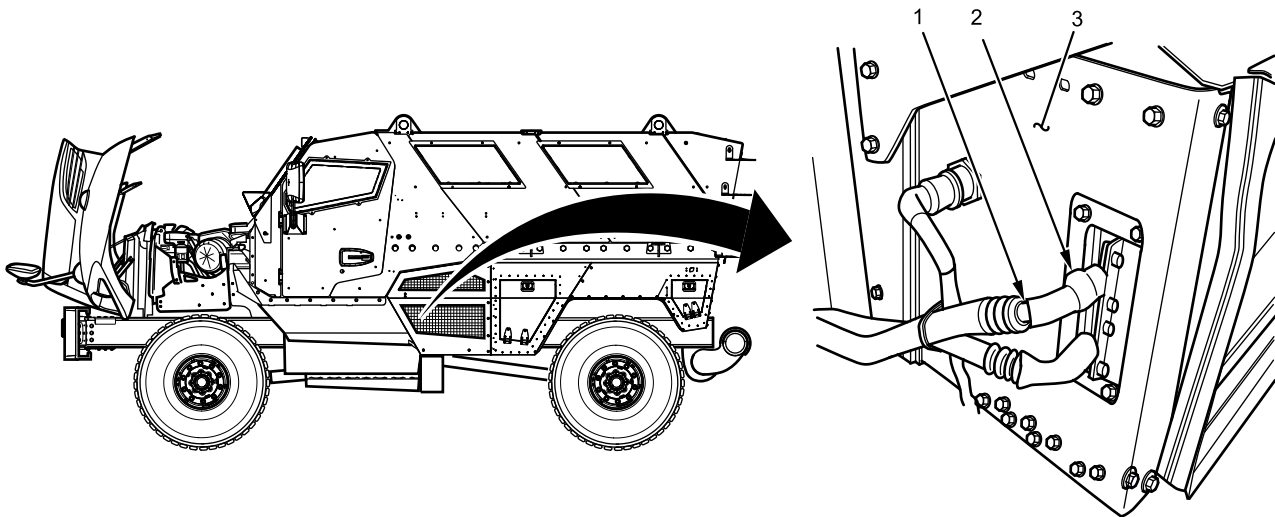

B232210692

Figure 4. Left Condenser Hose Fitting.

NOTE

Avoid spilling PAG oil when removing condenser inlet hose.

8. Disconnect condenser inlet hose (Figure 4, Item 1) from condenser (Figure 4, Item 3) and tape end of condenser inlet hose (Figure 4, Item 1).

NOTE

Do not remove wire from or pull wire completely through cab double-floor compartment. Wire must remain in vehicle to aid in installation of condenser inlet hose.

9. Pull condenser inlet hose (Figure 4, Item 1) towards condenser (Figure 4, Item 3) and under floor (Figure 5, Item 1) until condenser inlet hose is removed from vehicle.

HEATING VENTILATING AND AIR CONDITIONING (HVAC) LEFT-SIDE CONDENSER INLET HOSE REMOVAL AND INSTALLATION - (CONTINUED)

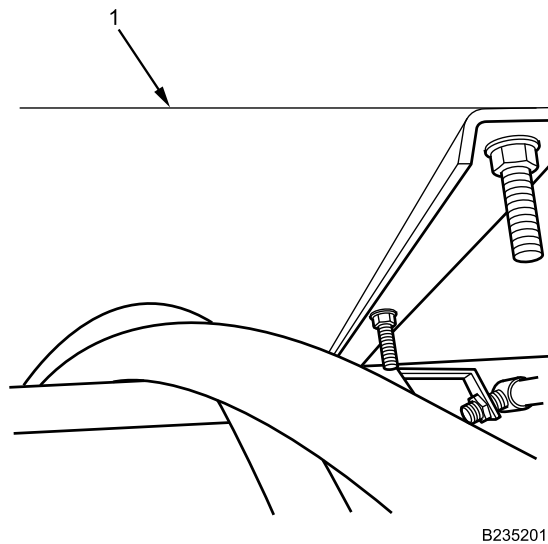

Figure 5. Left Rear Opening to Cab Double-Floor.

10. Disconnect wire (Figure 6, Item 3) from tee end of condenser inlet hose (Figure 6, Item 2).

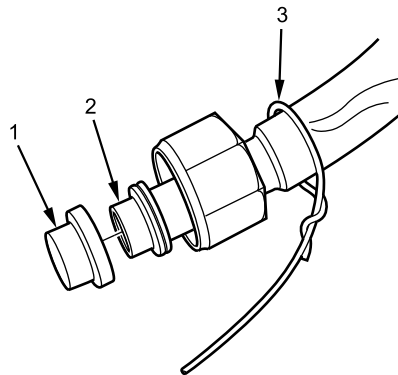

Figure 6. Condenser Hose.

11. Remove tape and cap (Figure 6, Item 1) from tee end of condenser inlet hose (Figure 6, Item 2).
12. Remove tape from condenser end of condenser inlet hose (Figure 6, Item 2).
13. Drain PAG oil from condenser inlet hose (Figure 6, Item 2) into liquid measure.
14. Record amount of PAG oil drained from condenser inlet hose and discard PAG oil.

END OF TASK

HEATING VENTILATING AND AIR CONDITIONING (HVAC) LEFT-SIDE CONDENSER INLET HOSE REMOVAL AND INSTALLATION - (CONTINUED)**INSTALLATION**

1. Remove O-ring from condenser end of condenser inlet hose (Figure 7, Item 1). Discard O-ring.

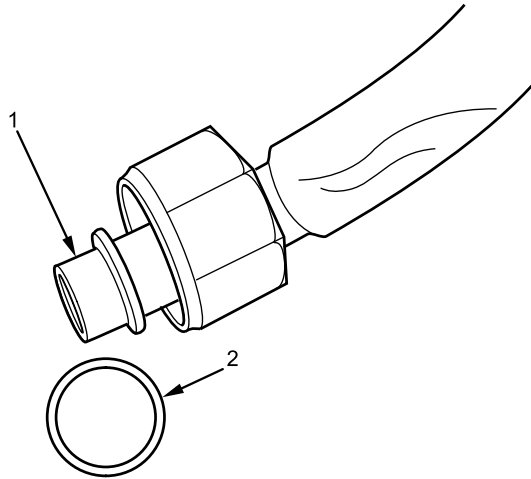

B235203066

Figure 7. Condenser Hose.

2. Coat new O-ring (Figure 7, Item 2) with PAG oil and install on condenser end of condenser inlet hose (Figure 7, Item 1).
3. Install condenser inlet hose (Figure 8, Item 1) on condenser (Figure 8, Item 3) and finger-tighten condenser inlet hose fitting (Figure 8, Item 2).

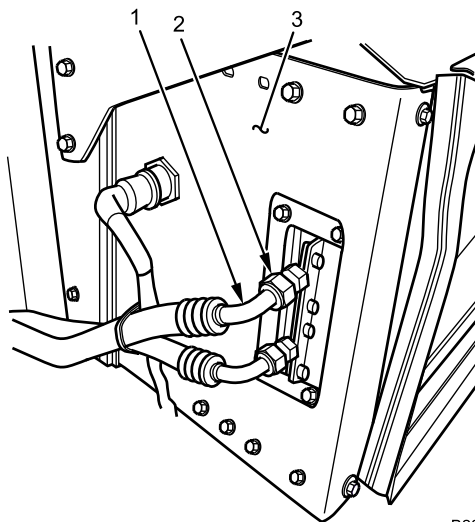

B232210693

Figure 8. Condenser Hose.

HEATING VENTILATING AND AIR CONDITIONING (HVAC) LEFT-SIDE CONDENSER INLET HOSE REMOVAL AND INSTALLATION - (CONTINUED)

CAUTION

Ensure cap is securely taped on tee end of condenser inlet hose to avoid contaminating condenser lines. Failure to comply may result in damage to HVAC components and equipment.

- Using tape, securely attach cap (Figure 9, Item 1) to tee end of condenser inlet hose (Figure 9, Item 2).

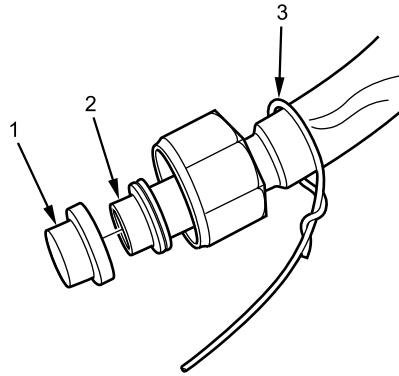

B232210691

Figure 9. Condenser Hose.

- Securely attach wire (Figure 9, Item 3) to end of condenser inlet hose.
- From engine compartment, pull wire attached to condenser inlet hose (Figure 10, Item 1) through cab double-floor rear opening (Figure 10, Item 2) until slack in condenser inlet hose (Figure 10, Item 1) is removed.

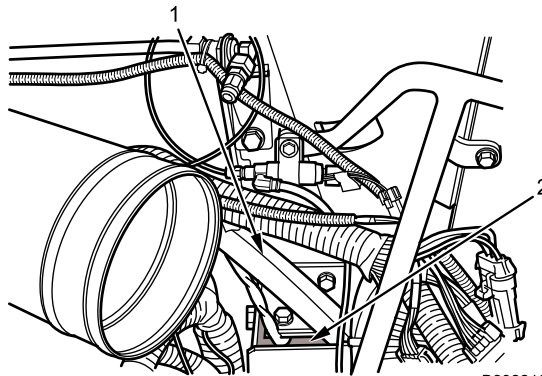

B232210695

Figure 10. Condenser Hoses.

HEATING VENTILATING AND AIR CONDITIONING (HVAC) LEFT-SIDE CONDENSER INLET HOSE REMOVAL AND INSTALLATION - (CONTINUED)

7. Remove tape and cap (Figure 11, Item 1) from end of condenser inlet hose (Figure 11, Item 2).

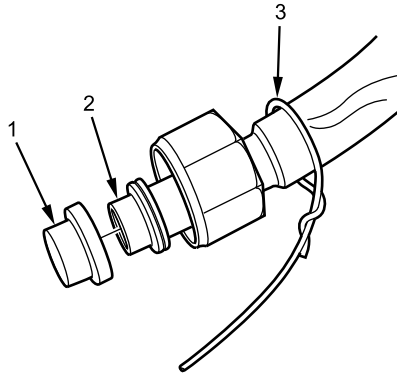

B232210691

Figure 11. Condenser Hose.

8. Disconnect wire (Figure 11, Item 3) and position end of condenser inlet hose (Figure 11, Item 3) near tee fitting.
 9. Remove and discard old O-ring from tee end of condenser inlet hose (Figure 12, Item 1).

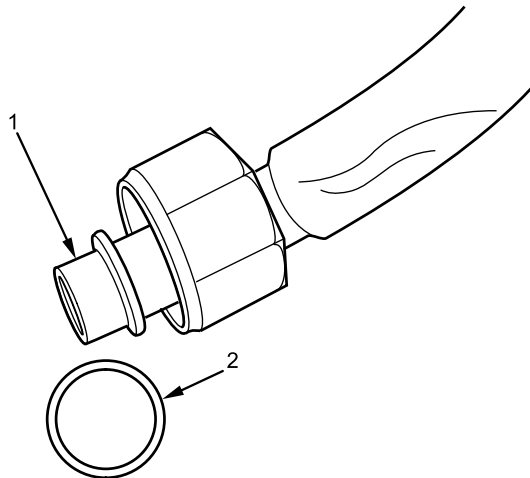

B235203066

Figure 12. Condenser Hose.

10. Add clean PAG oil, equal to amount drained, to end of condenser inlet hose (Figure 12, Item 1).
 11. Coat new O-ring (Figure 12, Item 2) with PAG oil and install on tee end of condenser inlet hose (Figure 12, Item 1).

HEATING VENTILATING AND AIR CONDITIONING (HVAC) LEFT-SIDE CONDENSER INLET HOSE REMOVAL AND INSTALLATION - (CONTINUED)

12. Connect condenser inlet hose (Figure 13, Item 3) to tee (Figure 13, Item 1) and finger-tighten.

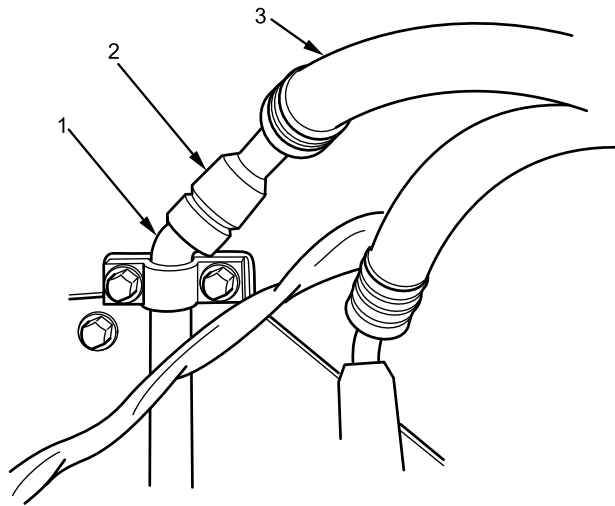

B235201555

Figure 13. Left HVAC Condenser Hose at Tee.

13. Tighten both condenser inlet hose fittings securely.
14. Install new cable lock straps where removed.

END OF TASK**FOLLOW-ON MAINTENANCE**

1. Install 3-way valve (WP 0727).
2. Evacuate and recharge HVAC system (WP 0707).
3. Install air cleaner housing (WP 0257).
4. Install air conditioning (A/C) condenser panel (WP 0672).
5. Install exterior fuel tank armor door (WP 0605).
6. Close and secure engine hood (TM 9-2355-106-10).
7. Remove wheel chocks (TM 9-2355-106-10).

END OF TASK**END OF WORK PACKAGE**

FIELD MAINTENANCE
**HEATING VENTILATING AND AIR CONDITIONING (HVAC) RIGHT-SIDE CONDENSER INLET HOSE
REMOVAL AND INSTALLATION**

INITIAL SETUP:**Tools and Special Tools**

General Mechanic's Tool Kit (GMTK)
(WP 0795, Item 37)
Cap and plug set (WP 0795, Item 23)
Measure, liquid, 2 qt (WP 0795, Item 71)
Gloves, rubber (WP 0795, Item 38)

TM 9-2355-106-23P

WP 0782

Materials/Parts

Faceshield, industrial (WP 0794, Item 16)
Tape (WP 0794, Item 51)
Wire (WP 0794, Item 57)
Lubricating oil (WP 0794, Item 31)
Cable lock strap - (6) (WP 0796, Item 134)
O-ring - (2) (WP 0796, Item 35)

Equipment Condition

Parking brake set (TM 9-2355-106-10)
Transmission set in NEUTRAL (N) (TM
9-2355-106-10)
Engine off (TM 9-2355-106-10)
MAIN POWER switch off (TM 9-2355-106-10)
Wheels chocked (TM 9-2355-106-10)
Engine hood open and secured (TM 9-2355-106-10)
HVAC system refrigerant recovered (WP 0707)
Air conditioning A/C condenser panel removed
(WP 0672)
Exterior battery box armor door removed (WP 0604)
3-Way valve removed (if required) (WP 0727)

References

TM 9-2355-106-10

HEATING VENTILATING AND AIR CONDITIONING (HVAC) RIGHT-SIDE CONDENSER INLET HOSE REMOVAL AND INSTALLATION - (CONTINUED)

WARNING

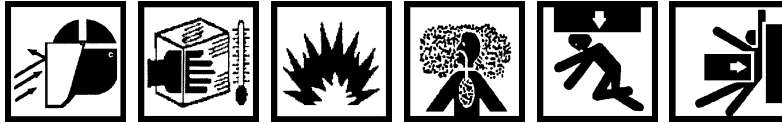

The temperature of liquid refrigerant is -20°F (-29°C). Wear full face shield, protective rubberized gloves, and protective clothing when working with refrigerant. If refrigerant contacts skin, remove all contaminated clothing. Treat skin as though it were frostbitten or frozen and seek immediate medical attention. If refrigerant contacts eyes, do not rub them. Flush eyes with cold water for at least 15 minutes to gradually increase temperature above freezing point. Seek immediate medical attention. Failure to comply may result in serious injury or death to personnel.

Do not expose refrigerant containers, empty or full, to open flames or temperatures above 125°F (52°C). Do not discard empty containers where they may be subject to heat from a trash burner; containers may explode. Failure to comply may result in damage to equipment and serious injury or death to personnel.

R-134a refrigerant must not be mixed with air and then pressurized. When mixed with large quantities of air and pressurized, R-134a becomes combustible. Failure to comply may result in damage to equipment and environment, and serious injury or death to personnel.

Federal and state laws require that refrigerant be recovered and recycled. Refrigerant must be recovered from system with authorized recommended equipment before any work can be performed on unit. Always use approved recycling equipment to prevent accidental discharge. Failure to comply may result in damage to equipment and environment, and serious injury or death to personnel.

Refrigerant evaporates very quickly and may displace oxygen in surrounding work area, especially in a small or enclosed area. This can cause suffocation or brain damage. If leak occurs, avoid breathing refrigerant vapor and thoroughly ventilate area before continuing service. If personnel breathe refrigerant vapors, obtain immediate medical assistance. Failure to comply may result in serious injury or death to personnel.

Do not install or remove air-conditioning testing or charging equipment while engine is running. Wait 30 seconds after engine shutdown to allow high side and low side pressures to equalize. Failure to comply may result in damage to equipment and environment, and serious injury or death to personnel.

Refrigerant becomes a poisonous gas in the presence of heat. Do not smoke or allow any type of flame in immediate area while servicing air conditioning system. Never weld, solder, steam clean, or use excessive heat on any part of the air conditioning system while charged/pressurized. Failure to comply may result in damage to equipment and serious injury or death to personnel.

Do not check compressor oil level when HVAC system is charged with refrigerant. Never open the high side hand valve of the manifold gauge set while HVAC system is operating. If hot, high pressure refrigerant is forced through gauge to refrigerant supply cylinder, which could rupture. Do not disconnect HVAC lines from compressor. Release of refrigerant may cause damage to equipment or environment and serious injury or death to personnel.

Do not use parts other than those specified for the system being serviced. Failure to comply may result in damage to equipment and serious injury or death to personnel.

HEATING VENTILATING AND AIR CONDITIONING (HVAC) RIGHT-SIDE CONDENSER INLET HOSE REMOVAL AND INSTALLATION - (CONTINUED)

Accidental or intentional introduction of liquid contaminants into the environment is a violation of state, federal, and military regulations. Store, install, and dispose of containers in accordance with standard operating procedures. Refer to Army POL (para. 1-8) for information concerning storage, use, and disposal of liquid contaminants. Failure to comply may result in damage to environment and serious injury or death to personnel.

Engine hood is extremely heavy and requires two-person lift. Ensure that there is adequate space in front of the vehicle to open hood completely without pinning or pinching personnel between hood and any other structure. Use extreme care when working under hood and make sure it is properly supported. Failure to comply may result in serious injury or death to personnel.

REMOVAL

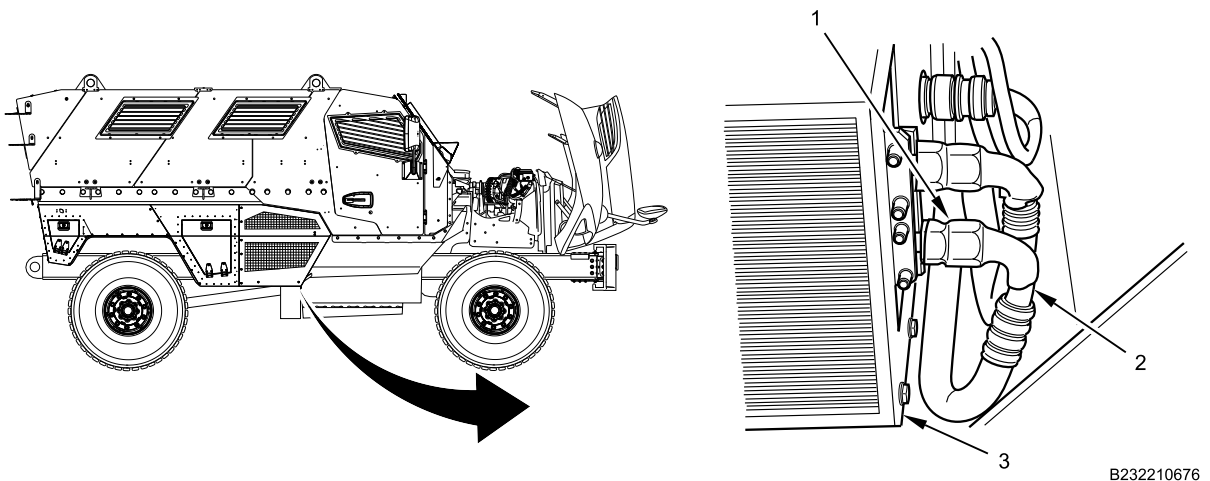

B232210676

Figure 1. Condenser Inlet Hose Fittings.

NOTE

Record location of cable lock straps before removing condenser inlet hose to aid in installation.

1. Remove heatshrink tubing (Figure 1, Item 1) from condenser inlet hose (Figure 1, Item 2) at right-side condenser (Figure 1, Item 3). Remove and discard cable lock straps as necessary.
2. Disconnect condenser inlet hose (Figure 1, Item 2) from right-side condenser (Figure 1, Item 3).
3. Drain PAG oil from right-side condenser end of condenser inlet hose (Figure 1, Item 2) into liquid measure.
4. Record amount of PAG oil drained from condenser inlet hose and discard PAG oil.

HEATING VENTILATING AND AIR CONDITIONING (HVAC) RIGHT-SIDE CONDENSER INLET HOSE REMOVAL AND INSTALLATION - (CONTINUED)

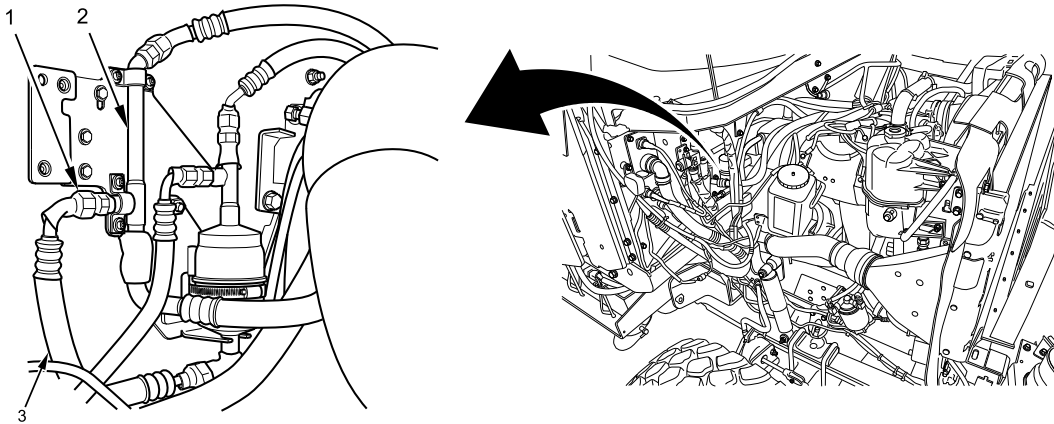

B232210674

Figure 2. Condenser Inlet Hose at Tee.

5. Remove heatshrink tubing (Figure 2, Item 1) from condenser inlet hose (Figure 2, Item 3) at tee (Figure 2, Item 2).
6. Disconnect condenser inlet hose (Figure 2, Item 3) from tee (Figure 2, Item 2).

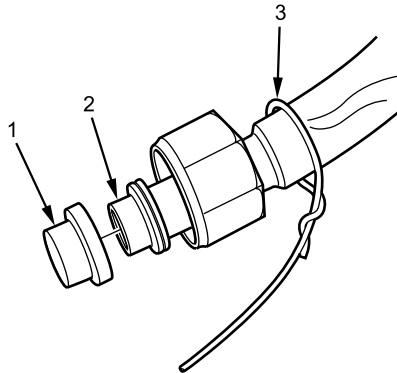

B232210691

Figure 3. Condenser Inlet Hose.

7. Using tape, securely attach cap (Figure 3, Item 1) to tee end of condenser inlet hose (Figure 3, Item 2).

CAUTION

Ensure caps are securely taped onto ends of condenser inlet hose. Failure to comply may allow condenser inlet hose to become contaminated and result in damage to HVAC components and equipment.

8. Securely attach end of wire to tee end of condenser inlet hose (Figure 3, Item 3) at engine compartment.

HEATING VENTILATING AND AIR CONDITIONING (HVAC) RIGHT-SIDE CONDENSER INLET HOSE REMOVAL AND INSTALLATION - (CONTINUED)

Figure 4. Cab Right-Side Double-Floor Front Opening.

9. From right-side condenser, pull condenser inlet hose with wire attached into cab right-side double-floor front opening (Figure 4, Item 1) at engine compartment.

NOTE

Do not remove wire from or pull wire completely through cab right-side double-floor compartment. Wire must remain in vehicle to aid in installation of condenser inlet hose.

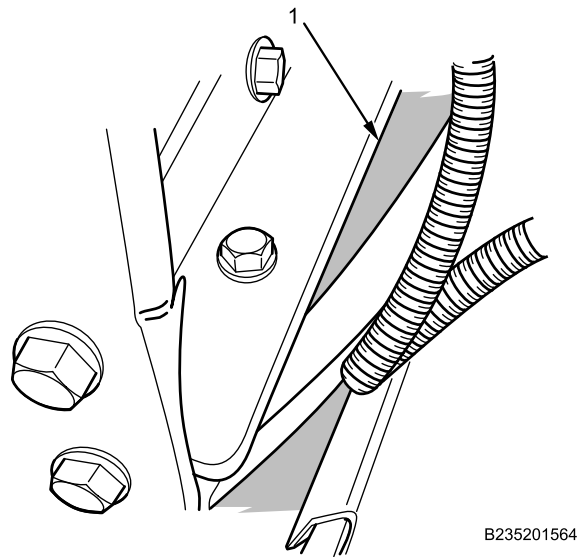
10. Pull condenser inlet hose towards right-side condenser and from rear opening until condenser inlet hose is removed from vehicle.
11. Disconnect wire from tee end of condenser inlet hose.
12. Remove tape and caps from ends of condenser inlet hose.

END OF TASK

HEATING VENTILATING AND AIR CONDITIONING (HVAC) RIGHT-SIDE CONDENSER INLET HOSE REMOVAL AND INSTALLATION - (CONTINUED)

INSTALLATION

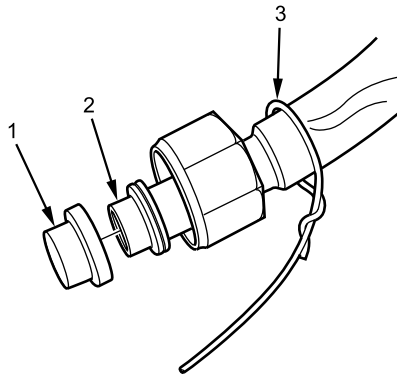

B232210691

Figure 5. Condenser Inlet Hose.

CAUTION

Ensure caps are securely taped onto ends of condenser inlet hose. Failure to comply may allow condenser inlet hose to become contaminated and result in damage to equipment.

1. Using tape, securely attach cap (Figure 5, Item 1) to tee end of condenser inlet hose (Figure 5, Item 2).
2. Securely attach end of wire at right-side condenser to tee end of condenser inlet hose (Figure 5, Item 3).

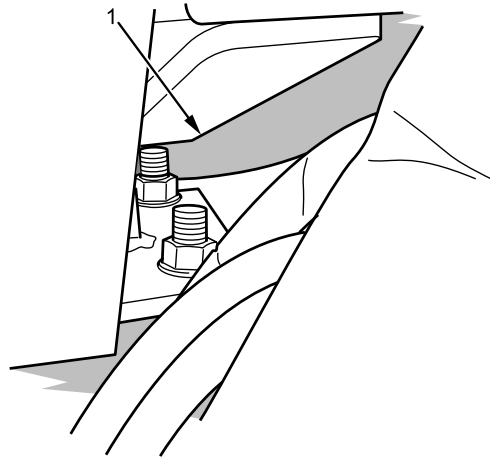

B235201563

Figure 6. Cab Right-Side Double-Floor Rear Opening.

3. From engine compartment, pull wire attached to condenser inlet hose into cab right-side double-floor rear opening (Figure 6, Item 1).
4. Pull wire attached to condenser inlet hose into cab double-floor right-side opening at engine compartment.

HEATING VENTILATING AND AIR CONDITIONING (HVAC) RIGHT-SIDE CONDENSER INLET HOSE REMOVAL AND INSTALLATION - (CONTINUED)

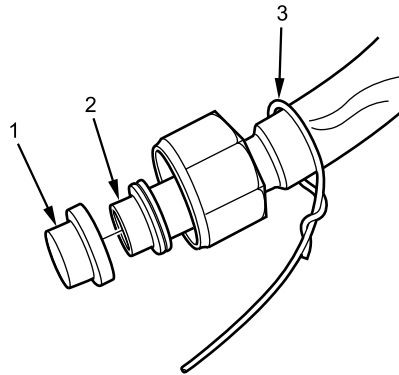

B232210691

Figure 7. Condenser Inlet Hose.

5. Disconnect wire (Figure 7, Item 3) from tee end of condenser inlet hose (Figure 7, Item 2).
6. Remove tape and caps (Figure 7, Item 1) from condenser inlet hose.

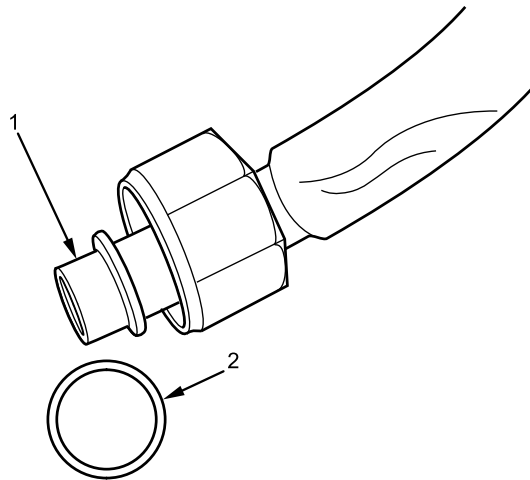

B235203066

Figure 8. O-Rings.

7. Remove O-rings from ends of condenser inlet hose (Figure 8, Item 1). Discard O-rings.
8. Coat new O-rings (Figure 8, Item 2) with PAG oil and install one O-ring on each end of condenser inlet hose (Figure 8, Item 1).

HEATING VENTILATING AND AIR CONDITIONING (HVAC) RIGHT-SIDE CONDENSER INLET HOSE REMOVAL AND INSTALLATION - (CONTINUED)

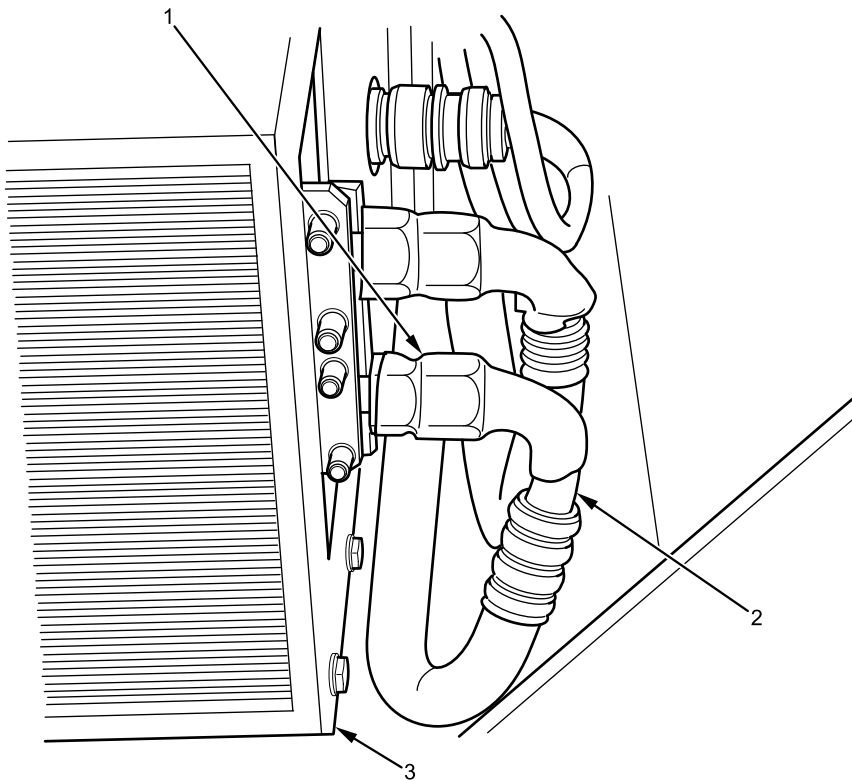

B232210675

Figure 9. Condenser Inlet Hose Fittings.

9. Connect condenser inlet hose (Figure 9, Item 2) to right-side condenser (Figure 9, Item 3) and finger-tighten condenser inlet hose fitting (Figure 9, Item 1).
10. Add clean PAG oil, equal to amount drained, to tee end of condenser inlet hose.

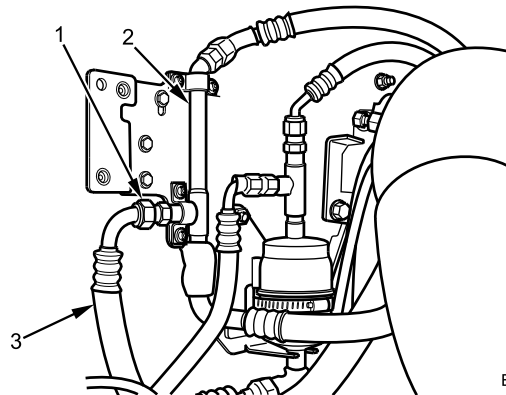

B232212038

Figure 10. Condenser Inlet Hose at Tee.

11. Connect condenser inlet hose (Figure 10, Item 3) to tee (Figure 10, Item 2) and finger-tighten condenser inlet hose fitting (Figure 10, Item 1).
12. Tighten both ends of condenser inlet hose fittings securely.
13. Install new cable lock straps where removed.

END OF TASK

**HEATING VENTILATING AND AIR CONDITIONING (HVAC) RIGHT-SIDE CONDENSER INLET HOSE
REMOVAL AND INSTALLATION - (CONTINUED)****FOLLOW-ON MAINTENANCE**

1. Install 3-way valve (if required) (WP 0727).
2. Install exterior battery box armor door (WP 0604).
3. Install Air Conditioning A/C condenser panel (WP 0672).
4. Evacuate and recharge HVAC system (WP 0707).
5. Close and secure engine hood (TM 9-2355-106-10).
6. Remove wheel chocks (TM 9-2355-106-10).

END OF TASK**END OF WORK PACKAGE**

FIELD MAINTENANCE
**HEATING VENTILATING AND AIR CONDITIONING (HVAC) LEFT-SIDE CONDENSER OUTLET HOSE
REMOVAL AND INSTALLATION**

INITIAL SETUP:**Tools and Special Tools**

General Mechanic's Tool Kit (GMTK)
(WP 0795, Item 37)
Cap and plug set (WP 0795, Item 23)
Measure, liquid, 2 qt (WP 0795, Item 71)
Gloves, rubber (WP 0795, Item 38)

Materials/Parts

Faceshield, industrial (WP 0794, Item 16)
Cable lock strap - (6) (WP 0796, Item 134)
Tape (WP 0794, Item 51)
Wire (WP 0794, Item 57)
Lubricating oil (WP 0794, Item 31)
O-ring - (2) (WP 0796, Item 34)

References

TM 9-2355-106-10

TM 9-2355-106-23P

WP 0782

Equipment Condition

Parking brake set (TM 9-2355-106-10)
Transmission set in NEUTRAL (N) (TM
9-2355-106-10)
Engine off (TM 9-2355-106-10)
MAIN POWER switch off (TM 9-2355-106-10)
Wheels chocked (TM 9-2355-106-10)
Engine hood open and secured (TM 9-2355-106-10)
Exterior fuel tank armor door removed (WP 0605)
Air conditioning A/C condenser panel removed
(WP 0672)
Air cleaner housing removed (WP 0257)
HVAC system evacuated and discharged (WP 0707)
3-Way valve removed (if required) (WP 0727)

HEATING VENTILATING AND AIR CONDITIONING (HVAC) LEFT-SIDE CONDENSER OUTLET HOSE REMOVAL AND INSTALLATION - (CONTINUED)

WARNING

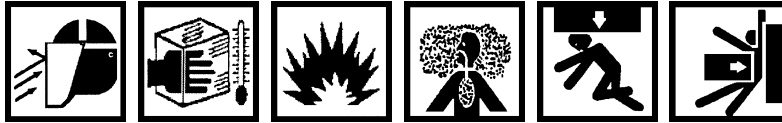

Federal and state laws require that refrigerant be recovered and recycled. Refrigerant must be recovered from system with authorized recommended equipment before any work can be performed on unit. Always use approved recycling equipment to prevent accidental discharge. Failure to comply may result in damage to equipment and environment, and serious injury or death to personnel.

Do not install or remove air-conditioning testing or charging equipment while engine is running. Wait 30 seconds after engine shutdown to allow high side and low side pressures to equalize. Failure to comply may result in damage to equipment and environment, and serious injury or death to personnel.

The temperature of liquid refrigerant is -20°F (-29°C). Wear full face shield, protective rubberized gloves, and protective clothing when working with refrigerant. If refrigerant contacts skin, remove all contaminated clothing. Treat skin as though it were frostbitten or frozen and seek immediate medical attention. If refrigerant contacts eyes, do not rub them. Flush eyes with cold water for at least 15 minutes to gradually increase temperature above freezing point. Seek immediate medical attention. Failure to comply may result in serious injury or death to personnel.

Do not expose refrigerant containers, empty or full, to open flames or temperatures above 125°F (52°C). Do not discard empty containers where they may be subject to heat from a trash burner; containers may explode. Failure to comply may result in damage to equipment and serious injury or death to personnel.

Engine hood is extremely heavy and requires two-person lift. Ensure that there is adequate space in front of the vehicle to open hood completely without pinning or pinching personnel between hood and any other structure. Use extreme care when working under hood and make sure it is properly supported. Failure to comply may result in serious injury or death to personnel.

R-134a refrigerant must not be mixed with air and then pressurized. When mixed with large quantities of air and pressurized, R-134a becomes combustible. Failure to comply may result in damage to equipment and environment, and serious injury or death to personnel.

Refrigerant evaporates very quickly and may displace oxygen in surrounding work area, especially in a small or enclosed area. This can cause suffocation or brain damage. If leak occurs, avoid breathing refrigerant vapor and thoroughly ventilate area before continuing service. If personnel breathe refrigerant vapors, obtain immediate medical assistance. Failure to comply may result in serious injury or death to personnel.

Refrigerant becomes a poisonous gas in the presence of heat. Do not smoke or allow any type of flame in immediate area while servicing air conditioning system. Never weld, solder, steam clean, or use excessive heat on any part of the air conditioning system while charged/pressurized. Failure to comply may result in damage to equipment and serious injury or death to personnel.

HEATING VENTILATING AND AIR CONDITIONING (HVAC) LEFT-SIDE CONDENSER OUTLET HOSE REMOVAL AND INSTALLATION - (CONTINUED)

Do not check compressor oil level when HVAC system is charged with refrigerant. Never open the high side hand valve of the manifold gauge set while HVAC system is operating. If hot, high pressure refrigerant is forced through gauge to refrigerant supply cylinder, which could rupture. Do not disconnect HVAC lines from compressor. Release of refrigerant may cause damage to equipment or environment and serious injury or death to personnel.

Do not use parts other than those specified for the system being serviced. Failure to comply may result in damage to equipment and serious injury or death to personnel.

Accidental or intentional introduction of liquid contaminants into the environment is a violation of state, federal, and military regulations. Store, install, and dispose of containers in accordance with standard operating procedures. Refer to Army POL (para. 1-8) for information concerning storage, use, and disposal of liquid contaminants. Failure to comply may result in damage to environment and serious injury or death to personnel.

REMOVAL

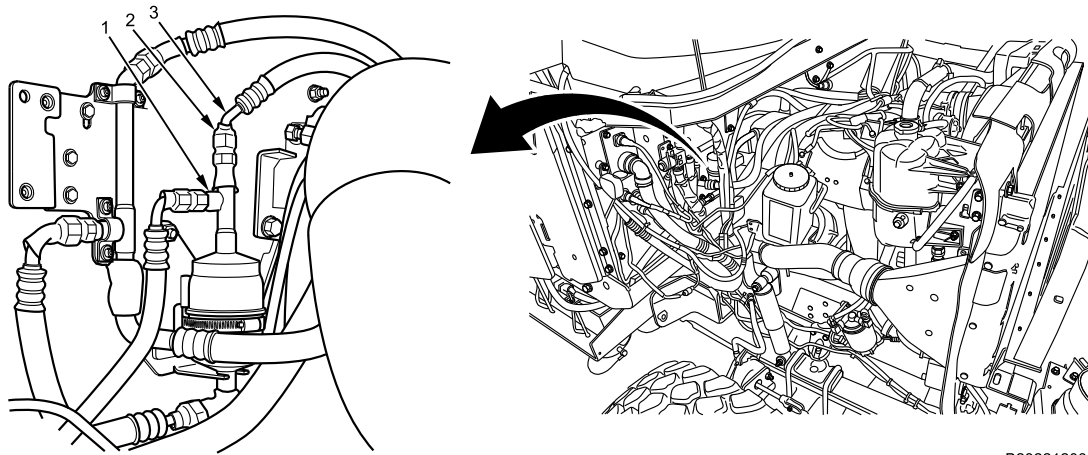

B232212032

Figure 1. Left Condenser Outlet Hose Fitting at HVAC Filter.

1. Remove heatshrink tubing (Figure 1, Item 2) from condenser outlet hose (Figure 1, Item 3) at HVAC filter tee (Figure 1, Item 1).
2. Remove and discard cable lock straps from condenser outlet hose (Figure 1, Item 3).

NOTE

Avoid spilling PAG oil when disconnecting condenser outlet hose.

3. Disconnect condenser outlet hose (Figure 1, Item 3) from HVAC filter tee (Figure 1, Item 1).

HEATING VENTILATING AND AIR CONDITIONING (HVAC) LEFT-SIDE CONDENSER OUTLET HOSE REMOVAL AND INSTALLATION - (CONTINUED)

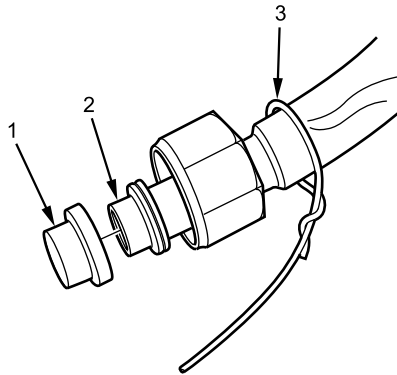

B232210691

Figure 2. Condenser Outlet Hose.

CAUTION

Ensure cap is securely taped on tee end of condenser outlet hose to avoid contaminating condenser line. Failure to comply may result in damage to HVAC components and equipment.

4. Using tape, securely attach cap (Figure 2, Item 1) to HVAC filter tee end of condenser outlet hose (Figure 2, Item 2).
5. Securely attach wire (Figure 2, Item 3) to end of condenser outlet hose.

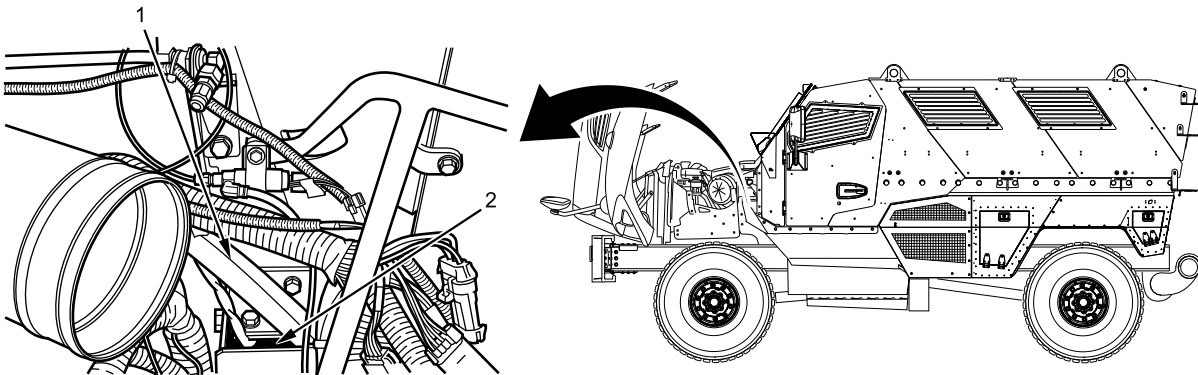

B232210694

Figure 3. Left Front Opening to Cab Double-Floor.

6. Position HVAC filter tee end of condenser outlet hose (Figure 3, Item 1) near left front cab double-floor compartment opening (Figure 3, Item 2).

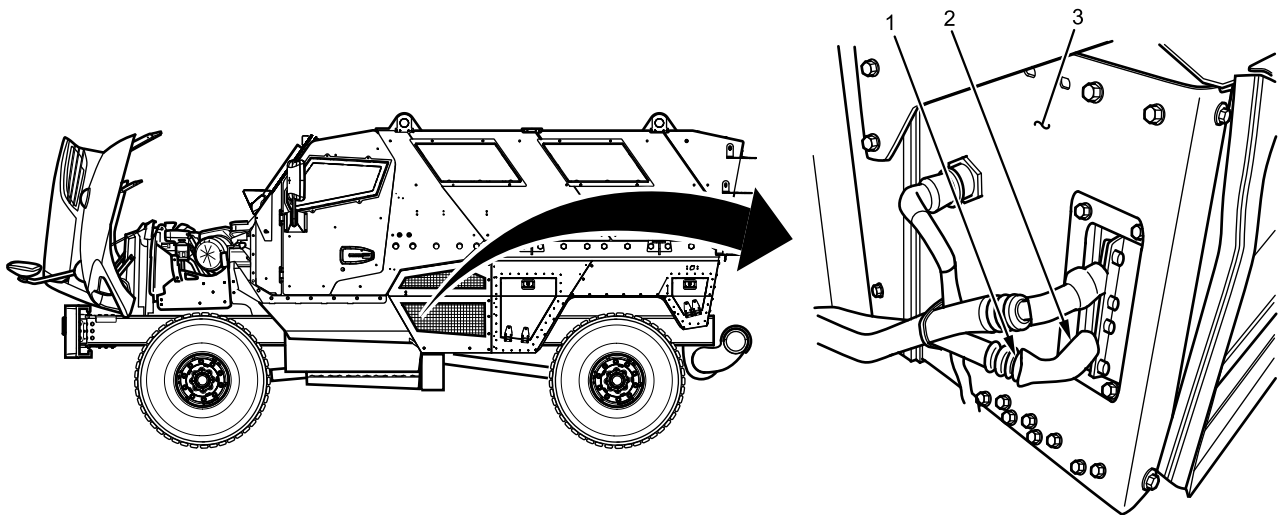
HEATING VENTILATING AND AIR CONDITIONING (HVAC) LEFT-SIDE CONDENSER OUTLET HOSE REMOVAL AND INSTALLATION - (CONTINUED)

B232212033

Figure 4. Left Condenser Outlet Hose Fitting.

7. Remove heatshrink tubing (Figure 4, Item 2) from condenser outlet hose (Figure 4, Item 1) at condenser (Figure 4, Item 3).

NOTE

Avoid spilling PAG oil when removing condenser outlet hose.

8. Disconnect condenser outlet hose (Figure 4, Item 1) from condenser (Figure 4, Item 3) and tape end of condenser outlet hose.

HEATING VENTILATING AND AIR CONDITIONING (HVAC) LEFT-SIDE CONDENSER OUTLET HOSE REMOVAL AND INSTALLATION - (CONTINUED)

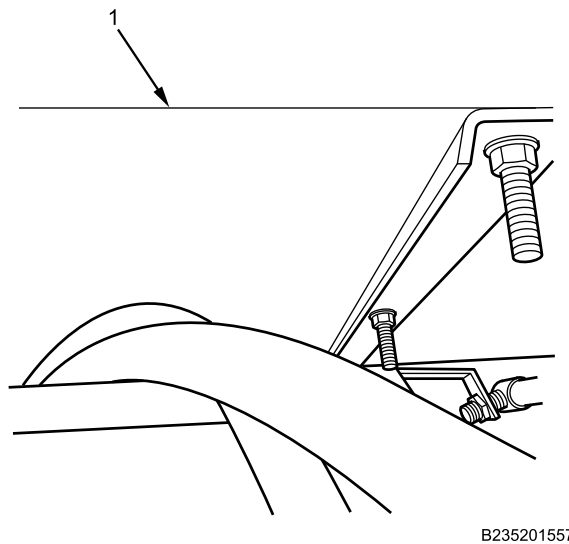
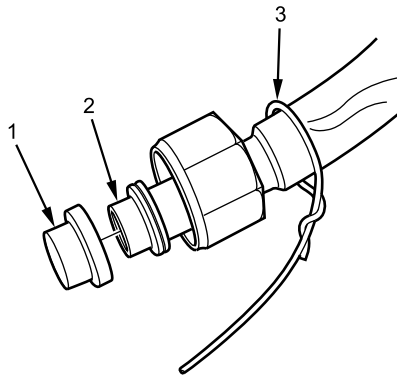

Figure 5. Left Rear Opening to Cab Double-Floor.

NOTE

Do not remove wire from or pull wire completely through cab double-floor compartment. Wire must remain in vehicle to aid in installation of condenser outlet hose.

9. Pull condenser outlet hose (Figure 4, Item 1) towards condenser (Figure 4, Item 3) and from under floor (Figure 5, Item 1) until condenser outlet hose is removed from vehicle.



B232210691

Figure 6. Condenser Outlet Hose.

10. Disconnect wire (Figure 6, Item 3) from HVAC filter tee end of condenser outlet hose (Figure 6, Item 2).
11. Remove tape and cap (Figure 6, Item 1) from HVAC filter tee end of condenser outlet hose (Figure 6, Item 2).
12. Remove tape from condenser end of condenser outlet hose (Figure 6, Item 2).
13. Drain PAG oil from condenser outlet hose (Figure 6, Item 2) into liquid measure.
14. Record amount of PAG oil drained from condenser outlet hose and discard PAG oil.

END OF TASK

HEATING VENTILATING AND AIR CONDITIONING (HVAC) LEFT-SIDE CONDENSER OUTLET HOSE REMOVAL AND INSTALLATION - (CONTINUED)

INSTALLATION

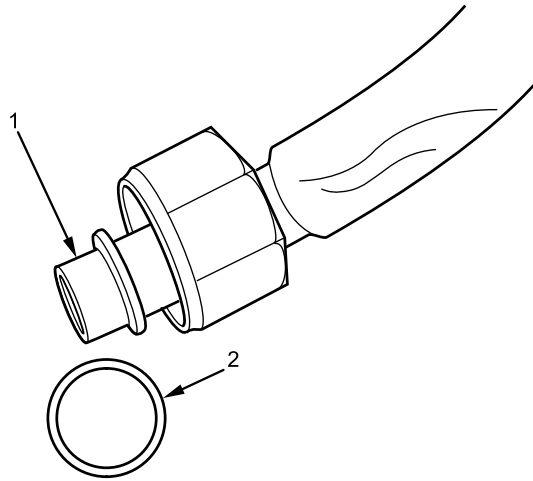

B235203066

Figure 7. Condenser Hose.

1. Remove O-ring (Figure 7, Item 2) from condenser end of condenser outlet hose (Figure 7, Item 1). Discard O-ring.
2. Coat new O-ring (Figure 7, Item 2) with PAG oil and install on condenser end of condenser outlet hose (Figure 7, Item 1).

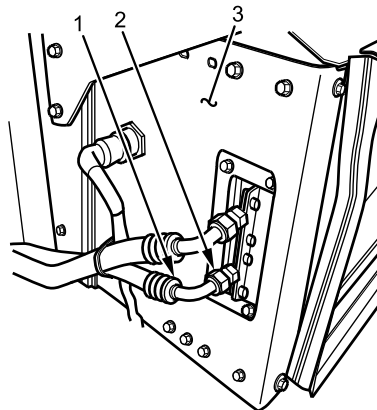

B232212034

Figure 8. Condenser Hose.

3. Install condenser outlet hose (Figure 8, Item 1) on condenser (Figure 8, Item 3) and finger-tighten condenser outlet hose fitting (Figure 8, Item 2).

HEATING VENTILATING AND AIR CONDITIONING (HVAC) LEFT-SIDE CONDENSER OUTLET HOSE REMOVAL AND INSTALLATION - (CONTINUED)

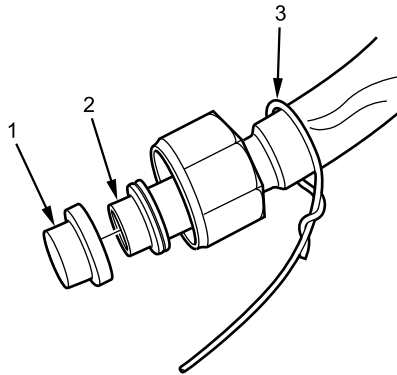

B232210691

Figure 9. Condenser Hose.

CAUTION

Ensure cap is securely taped on tee end of condenser outlet hose to avoid contaminating condenser lines. Failure to comply may result in damage to HVAC components and equipment.

4. Using tape, securely attach cap (Figure 9, Item 1) to HVAC filter tee end of condenser outlet hose (Figure 9, Item 2).
5. Securely attach wire (Figure 9, Item 3) to end of condenser outlet hose.

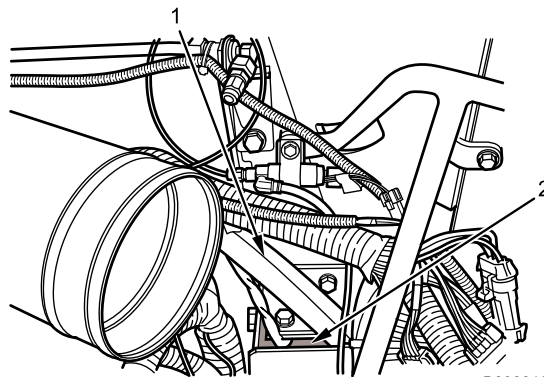

B232210695

Figure 10. Condenser Hose.

6. From engine compartment, pull wire attached to condenser outlet hose (Figure 10, Item 1) through cab double-floor rear opening (Figure 10, Item 2) until slack in condenser outlet hose is removed.

HEATING VENTILATING AND AIR CONDITIONING (HVAC) LEFT-SIDE CONDENSER OUTLET HOSE REMOVAL AND INSTALLATION - (CONTINUED)

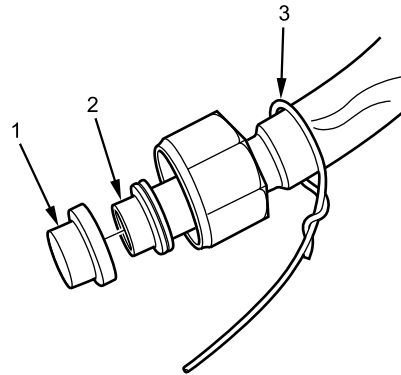

B232210691

Figure 11. Condenser Hose.

7. Remove tape and cap (Figure 11, Item 1) from HVAC filter end of condenser outlet hose (Figure 11, Item 2).
8. Disconnect wire (Figure 11, Item 3) and position end of condenser outlet hose (Figure 11, Item 3) near HVAC filter tee fitting.

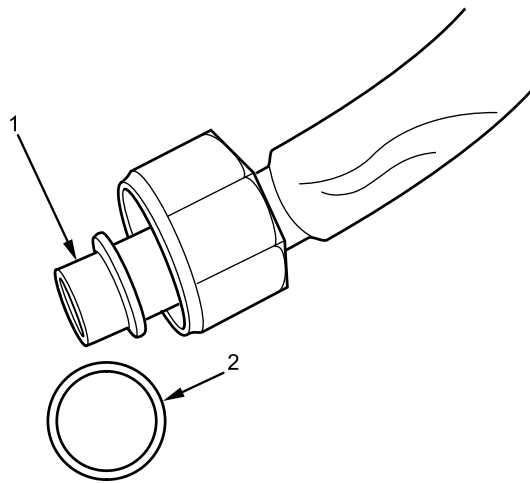

B235203066

Figure 12. Condenser Hose.

9. Remove and discard O-ring from HVAC filter tee end of condenser outlet hose (Figure 12, Item 1).
10. Add clean PAG oil, equal to amount drained, to HVAC filter tee end of condenser outlet hose (Figure 12, Item 1).
11. Coat new O-ring (Figure 12, Item 2) with PAG oil and install on HVAC filter tee end of condenser outlet hose (Figure 12, Item 1).

HEATING VENTILATING AND AIR CONDITIONING (HVAC) LEFT-SIDE CONDENSER OUTLET HOSE REMOVAL AND INSTALLATION - (CONTINUED)

Figure 13. Left HVAC Condenser Hose at Tee.

12. Connect condenser outlet hose (Figure 13, Item 3) to HVAC filter tee (Figure 13, Item 1) and finger-tighten condenser outlet hose fitting (Figure 13, Item 2).
13. Tighten both condenser inlet hose fittings securely.
14. Install new cable lock straps where removed.

END OF TASK**FOLLOW-ON MAINTENANCE**

1. Install 3-way valve (if required) (WP 0727).
2. Evacuate and recharge HVAC system (WP 0707).
3. Install air cleaner housing (WP 0257).
4. Install air conditioning A/C condenser panel (WP 0672).
5. Install exterior fuel tank armor door (WP 0605).
6. Close and secure engine hood (TM 9-2355-106-10).
7. Remove wheel chocks (TM 9-2355-106-10).

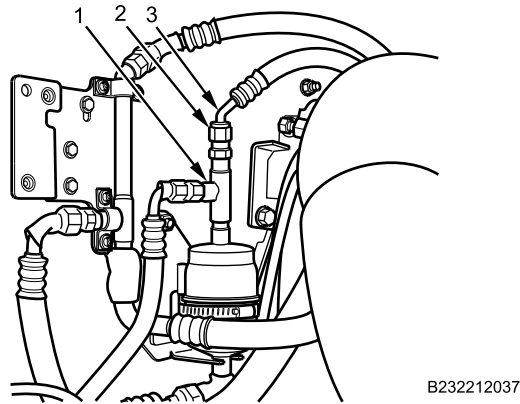
END OF TASK**END OF WORK PACKAGE**

FIELD MAINTENANCE
**HEATING VENTILATING AND AIR CONDITIONING (HVAC) RIGHT-SIDE CONDENSER OUTLET HOSE
REMOVAL AND INSTALLATION**

INITIAL SETUP:**Tools and Special Tools**

General Mechanic's Tool Kit (GMTK)
(WP 0795, Item 37)
Measure, liquid, 2 qt (WP 0795, Item 71)
Gloves, rubber (WP 0795, Item 38)
Cap and plug set (WP 0795, Item 23)

TM 9-2355-106-23P

WP 0782

Materials/Parts

Faceshield, industrial (WP 0794, Item 16)
Lubricating oil (WP 0794, Item 31)
Tape (WP 0794, Item 51)
Wire (WP 0794, Item 57)
O-ring - (2) (WP 0796, Item 37)
Cable lock strap - (3) (WP 0796, Item 124)

Equipment Condition

Parking brake set (TM 9-2355-106-10)
Transmission set in NEUTRAL (N) (TM
9-2355-106-10)
Engine off (TM 9-2355-106-10)
MAIN POWER switch off (TM 9-2355-106-10)
Wheels chocked (TM 9-2355-106-10)
Engine hood open and secured (TM 9-2355-106-10)
HVAC system evacuated and discharged (WP 0707)
Air Conditioning A/C condenser panel removed
(WP 0672)
Right side engine armor panel removed (WP 0599)
Exterior battery box armor door removed (WP 0604)

References

TM 9-2355-106-10

HEATING VENTILATING AND AIR CONDITIONING (HVAC) RIGHT-SIDE CONDENSER OUTLET HOSE REMOVAL AND INSTALLATION - (CONTINUED)

WARNING

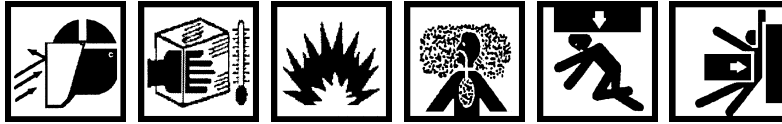

The temperature of liquid refrigerant is -20°F (-29°C). Wear full faceshield, protective rubberized gloves, and protective clothing when working with refrigerant. If refrigerant contacts skin, remove all contaminated clothing. Treat skin as though it were frostbitten or frozen and seek immediate medical attention. If refrigerant contacts eyes, do not rub them. Flush eyes with cold water for at least 15 minutes to gradually increase temperature above freezing point. Seek immediate medical attention. Failure to comply may result in serious injury or death to personnel.

Do not expose refrigerant containers, empty or full, to open flames or temperatures above 125°F (52°C). Do not discard empty containers where they may be subject to heat from a trash burner; containers may explode. Failure to comply may result in damage to equipment and serious injury or death to personnel.

R-134a refrigerant must not be mixed with air and then pressurized. When mixed with large quantities of air and pressurized, R-134a becomes combustible. Failure to comply may result in damage to equipment and environment, and serious injury or death to personnel.

Federal and state laws require that refrigerant be recovered and recycled. Refrigerant must be recovered from system with authorized recommended equipment before any work can be performed on unit. Always use approved recycling equipment to prevent accidental discharge. Failure to comply may result in damage to equipment and environment, and serious injury or death to personnel.

Refrigerant evaporates very quickly and may displace oxygen in surrounding work area, especially in a small or enclosed area. This can cause suffocation or brain damage. If leak occurs, avoid breathing refrigerant vapor and thoroughly ventilate area before continuing service. If personnel breathe refrigerant vapors, obtain immediate medical assistance. Failure to comply may result in serious injury or death to personnel.

Do not install or remove air-conditioning testing or charging equipment while engine is running. Wait 30 seconds after engine shutdown to allow high side and low side pressures to equalize. Failure to comply may result in damage to equipment and environment, and serious injury or death to personnel.

Refrigerant becomes a poisonous gas in the presence of heat. Do not smoke or allow any type of flame in immediate area while servicing air conditioning system. Never weld, solder, steam clean, or use excessive heat on any part of the air conditioning system while charged/pressurized. Failure to comply may result in damage to equipment and serious injury or death to personnel.

Do not check compressor oil level when HVAC system is charged with refrigerant. Never open the high side hand valve of the manifold gauge set while HVAC system is operating. If hot, high pressure refrigerant is forced through gauge to refrigerant supply cylinder, which could rupture. Do not disconnect HVAC lines from compressor. Release of refrigerant may cause damage to equipment or environment and serious injury or death to personnel.

Do not use parts other than those specified for the system being serviced. Failure to comply may result in damage to equipment and serious injury or death to personnel.

HEATING VENTILATING AND AIR CONDITIONING (HVAC) RIGHT-SIDE CONDENSER OUTLET HOSE REMOVAL AND INSTALLATION - (CONTINUED)

Accidental or intentional introduction of liquid contaminants into the environment is a violation of state, federal, and military regulations. Store, install, and dispose of containers in accordance with standard operating procedures. Refer to Army POL (para. 1-8) for information concerning storage, use, and disposal of liquid contaminants. Failure to comply may result in damage to environment and serious injury or death to personnel.

Engine hood is extremely heavy and requires two-person lift. Ensure that there is adequate space in front of the vehicle to open hood completely without pinning or pinching personnel between hood and any other structure. Use extreme care when working under hood and make sure it is properly supported. Failure to comply may result in serious injury or death to personnel.

REMOVAL

NOTE

Record location of cable lock straps before removing condenser outlet hose to aid in installation.

1. Remove heatshrink tubing (Figure 1, Item 2) from condenser outlet hose (Figure 1, Item 1) at condenser (Figure 1, Item 3). Remove and discard cable lock straps as necessary.

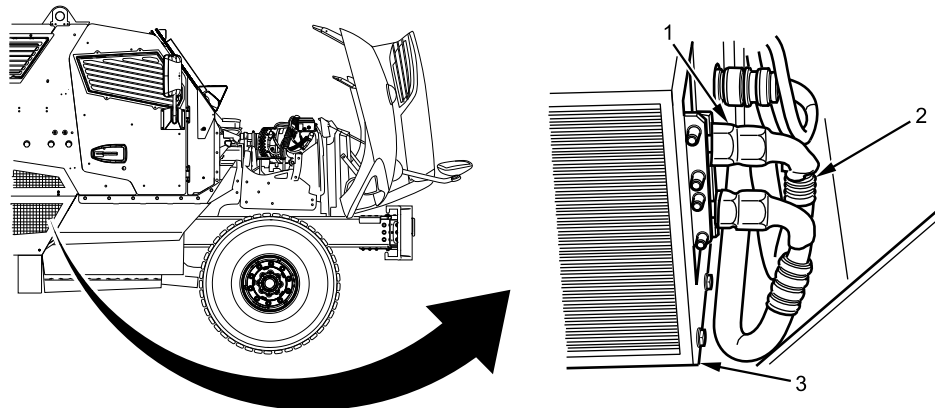

B232210685

Figure 1. Right HVAC Condenser Hose Fittings.

2. Disconnect condenser outlet hose (Figure 1, Item 1) from condenser.
3. Drain PAG oil from condenser outlet hose (Figure 1, Item 1) into liquid measure.

HEATING VENTILATING AND AIR CONDITIONING (HVAC) RIGHT-SIDE CONDENSER OUTLET HOSE REMOVAL AND INSTALLATION - (CONTINUED)

4. Remove heatshrink tubing (Figure 2, Item 1) from condenser outlet hose (Figure 2, Item 3) at tee (Figure 2, Item 2).

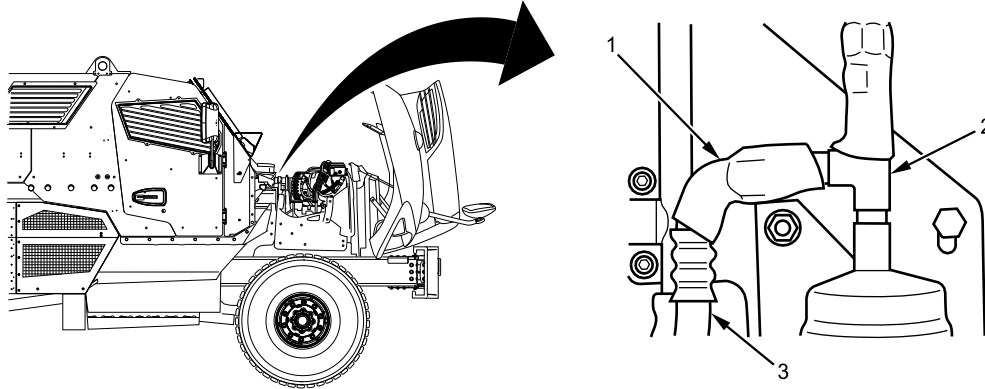

B231810501

Figure 2. Right HVAC Condenser Hose at Filter.

5. Disconnect condenser outlet hose (Figure 2, Item 3) from tee (Figure 2, Item 2).
6. Remove and discard two O-rings from condenser outlet hose.
7. Cap and plug both ends of condenser outlet hose.

CAUTION

Ensure caps are taped onto ends of condenser outlet hose securely. Failure to comply may allow condenser outlet hose to become contaminated and result in damage to equipment.

8. Securely connect end of mechanics wire at condenser to front end of condenser outlet hose (Figure 2, Item 3) at engine compartment.
9. From end of condenser outlet hose at condenser, pull condenser outlet hose and wire into cab double-floor engine compartment opening (Figure 3, Item 1) and out rear opening (Figure 4, Item 1) toward condenser.

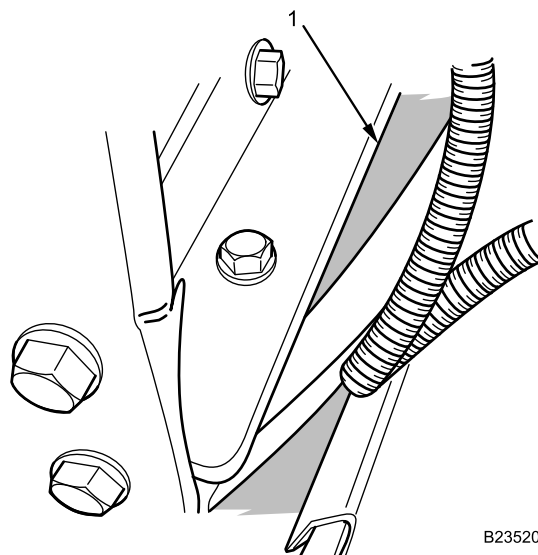

B235201564

Figure 3. Right Front Opening to Cab Double-Floor.

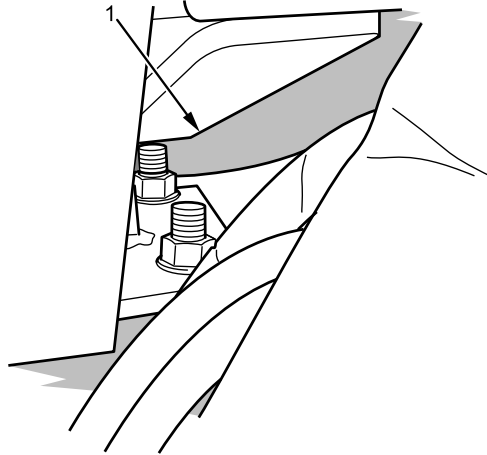
**HEATING VENTILATING AND AIR CONDITIONING (HVAC) RIGHT-SIDE CONDENSER OUTLET HOSE
REMOVAL AND INSTALLATION - (CONTINUED)**

B235201563

Figure 4. Right Rear Opening to Cab Double-Floor.

10. Disconnect mechanic's wire from condenser outlet hose.
11. Drain remaining oil from condenser outlet hose into measured container.

END OF TASK

HEATING VENTILATING AND AIR CONDITIONING (HVAC) RIGHT-SIDE CONDENSER OUTLET HOSE REMOVAL AND INSTALLATION - (CONTINUED)

INSTALLATION

CAUTION

Ensure caps are taped onto ends of condenser outlet hose securely. Failure to comply may allow condenser outlet hose to become contaminated and result in damage to equipment.

1. Securely connect end of mechanic's wire at condenser to front end of condenser outlet hose.
2. From engine compartment, pull wire and condenser outlet hose into cab double-floor rear opening (Figure 5, Item 1) and out of engine compartment opening (Figure 6, Item 1).

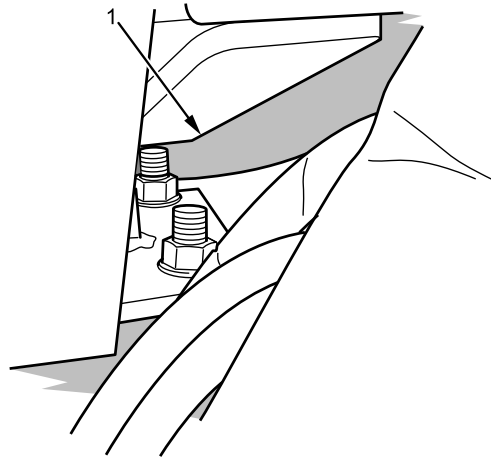

B235201563

Figure 5. Right Rear Opening to Cab Double-Floor.

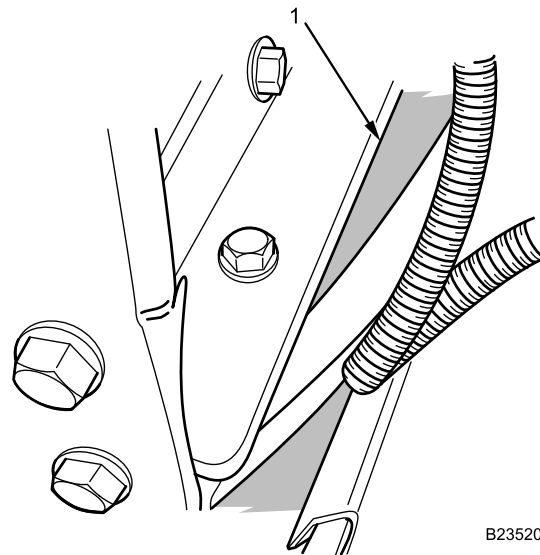

B235201564

Figure 6. Left Front Opening to Cab Double-Floor.

3. Disconnect mechanic's wire from condenser outlet hose.
4. Remove cap and plug from both ends of condenser outlet hose.
5. Coat new O-rings with PAG oil and install one O-ring on each end of condenser outlet hose.

HEATING VENTILATING AND AIR CONDITIONING (HVAC) RIGHT-SIDE CONDENSER OUTLET HOSE REMOVAL AND INSTALLATION - (CONTINUED)

6. Connect condenser outlet hose (Figure 7, Item 2) to condenser (Figure 7, Item 3) and finger-tighten (Figure 7, Item 1).

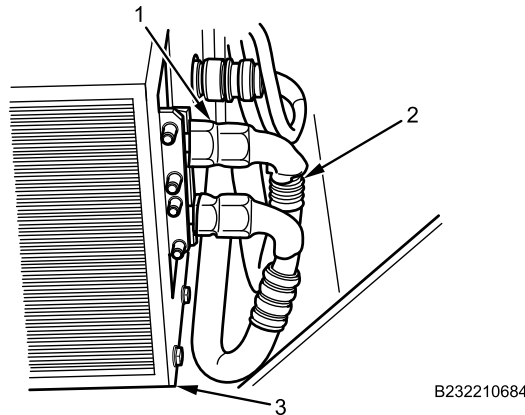

Figure 7. Right HVAC Condenser Hose Fittings.

7. Add clean PAG oil, equal to amount drained from condenser outlet hose (Figure 7, Item 2), to other end of condenser outlet hose.
8. Connect condenser outlet hose (Figure 8, Item 3) to tee (Figure 8, Item 2) and finger tighten nut (Figure 8, Item 1).

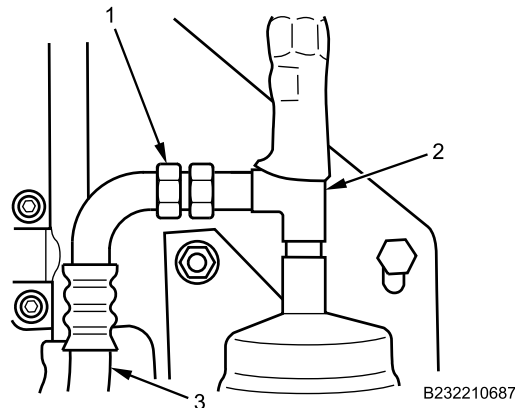

Figure 8. Right HVAC Condenser Hose at Tee.

9. Tighten condenser outlet hose fittings securely.
10. Install new cable lock straps where removed.

END OF TASK

**HEATING VENTILATING AND AIR CONDITIONING (HVAC) RIGHT-SIDE CONDENSER OUTLET HOSE
REMOVAL AND INSTALLATION - (CONTINUED)****FOLLOW-ON MAINTENANCE**

1. Evacuate and recharge HVAC system (WP 0707).
2. Install Air Conditioning A/C condenser panel (WP 0672).
3. Install right side engine armor panel (WP 0599).
4. Install battery box armor door (WP 0604).
5. Close and secure engine hood (TM 9-2355-106-10).
6. Remove wheel chocks (TM 9-2355-106-10).

END OF TASK**END OF WORK PACKAGE**

FIELD MAINTENANCE**HEATING VENTILATING AND AIR CONDITIONING (HVAC) COMPRESSOR DISCHARGE HOSE REMOVAL AND INSTALLATION**

INITIAL SETUP:**Tools and Special Tools**

General Mechanic's Tool Kit (GMTK)
(WP 0795, Item 37)
Gloves, rubber (WP 0795, Item 38)
Measure, liquid, 2 qt (WP 0795, Item 71)

Materials/Parts

Faceshield, industrial (WP 0794, Item 16)
Lubricating oil (WP 0794, Item 31)
Tubing (WP 0794, Item 56)
O-ring - (2) (WP 0796, Item 36)
Cable lock strap - (6) (WP 0796, Item 134)

Personnel Required

Maintainer - (2)

References

TM 9-2355-106-10
TM 9-2355-106-23P
WP 0786
WP 0782

Equipment Condition

Parking brake set (TM 9-2355-106-10)
Transmission set in NEUTRAL (N) (TM 9-2355-106-10)
Engine off (TM 9-2355-106-10)
MAIN POWER switch off (TM 9-2355-106-10)
Wheels chocked (TM 9-2355-106-10)
Engine hood open and secured (TM 9-2355-106-10)
HVAC system evacuated and discharged (WP 0707)

HEATING VENTILATING AND AIR CONDITIONING (HVAC) COMPRESSOR DISCHARGE HOSE REMOVAL AND INSTALLATION - (CONTINUED)

WARNING

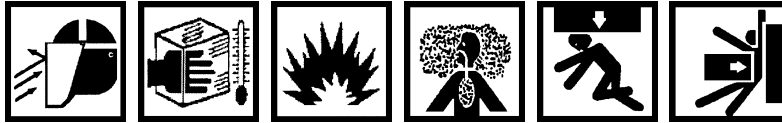

The temperature of liquid refrigerant is -20°F (-29°C). Wear full faceshield, protective rubberized gloves, and protective clothing when working with refrigerant. If refrigerant contacts skin, remove all contaminated clothing. Treat skin as though it were frostbitten or frozen and seek immediate medical attention. If refrigerant contacts eyes, do not rub them. Flush eyes with cold water for at least 15 minutes to gradually increase temperature above freezing point. Seek immediate medical attention. Failure to comply may result in serious injury or death to personnel.

Do not expose refrigerant containers, empty or full, to open flames or temperatures above 125°F (52°C). Do not discard empty containers where they may be subject to heat from a trash burner; containers may explode. Failure to comply may result in damage to equipment and serious injury or death to personnel.

R-134a refrigerant must not be mixed with air and then pressurized. When mixed with large quantities of air and pressurized, R-134a becomes combustible. Failure to comply may result in damage to equipment and environment, and serious injury or death to personnel.

Federal and state laws require that refrigerant be recovered and recycled. Refrigerant must be recovered from system with authorized recommended equipment before any work can be performed on unit. Always use approved recycling equipment to prevent accidental discharge. Failure to comply may result in damage to equipment and environment, and serious injury or death to personnel.

Refrigerant evaporates very quickly and may displace oxygen in surrounding work area, especially in a small or enclosed area. This can cause suffocation or brain damage. If leak occurs, avoid breathing refrigerant vapor and thoroughly ventilate area before continuing service. If personnel breathe refrigerant vapors, obtain immediate medical assistance. Failure to comply may result in serious injury or death to personnel.

Do not install or remove air-conditioning testing or charging equipment while engine is running. Wait 30 seconds after engine shutdown to allow high side and low side pressures to equalize. Failure to comply may result in damage to equipment and environment, and serious injury or death to personnel.

Refrigerant becomes a poisonous gas in the presence of heat. Do not smoke or allow any type of flame in immediate area while servicing air conditioning system. Never weld, solder, steam clean, or use excessive heat on any part of the air conditioning system while charged/pressurized. Failure to comply may result in damage to equipment and serious injury or death to personnel.

Do not check compressor oil level when HVAC system is charged with refrigerant. Never open the high side hand valve of the manifold gauge set while HVAC system is operating. If hot, high pressure refrigerant is forced through gauge to refrigerant supply cylinder, which could rupture. Do not disconnect HVAC lines from compressor. Release of refrigerant may cause damage to equipment or environment and serious injury or death to personnel.

Do not use parts other than those specified for the system being serviced. Failure to comply may result in damage to equipment and serious injury or death to personnel.

HEATING VENTILATING AND AIR CONDITIONING (HVAC) COMPRESSOR DISCHARGE HOSE REMOVAL AND INSTALLATION - (CONTINUED)

Accidental or intentional introduction of liquid contaminants into the environment is a violation of state, federal, and military regulations. Store, install, and dispose of containers in accordance with standard operating procedures. Refer to Army Petroleum, Oil, and Lubricants (POL) (para. 1-8) for information concerning storage, use, and disposal of liquid contaminants. Failure to comply may result in damage to environment and serious injury or death to personnel.

Engine hood is extremely heavy and requires two-person lift. Ensure that there is adequate space in front of the vehicle to open hood completely without pinning or pinching personnel between hood and any other structure. Use extreme care when working under hood and make sure it is properly supported. Failure to comply may result in serious injury or death to personnel.

NOTE

Remove cable lock straps as necessary to perform procedure. Note position and size of cable lock straps to aid installation.

REMOVAL

1. Remove two screws and flat washers (Figure 1, Item 1) and position 3-way valve (Figure 1, Item 2) aside.

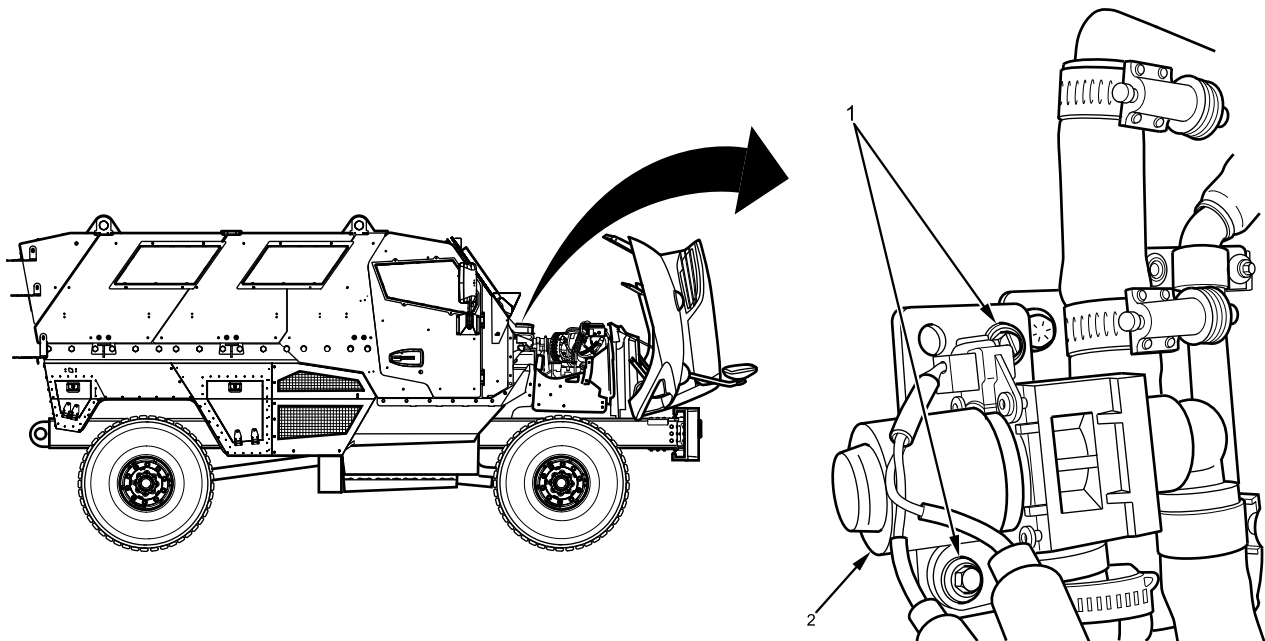

B235210595

Figure 1. 3-Way Valve.

HEATING VENTILATING AND AIR CONDITIONING (HVAC) COMPRESSOR DISCHARGE HOSE REMOVAL AND INSTALLATION - (CONTINUED)

Figure 2. Compressor Discharge Hose Heat Shrink Tubing.

2. Remove heat shrink tubing (Figure 2, Item 2) from compressor discharge hose (Figure 2, Item 1) and outlet.

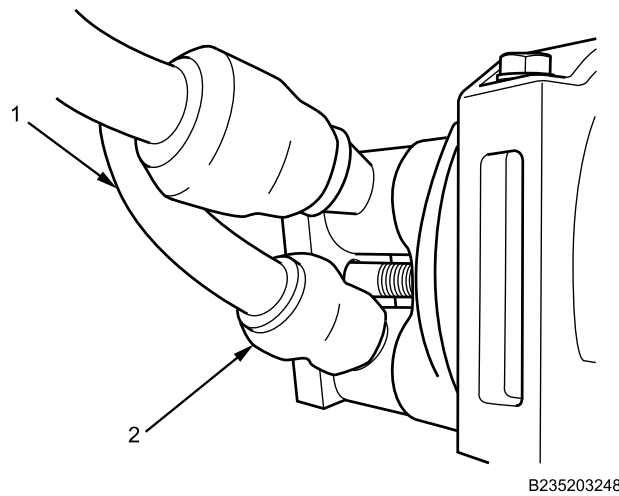
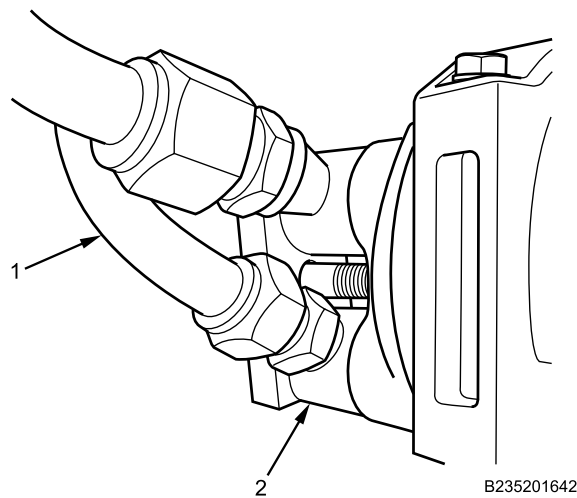
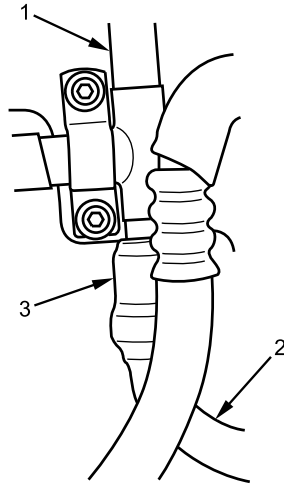

Figure 3. HVAC Compressor Discharge Hose at Compressor.

3. Disconnect HVAC compressor discharge hose (Figure 3, Item 1) from HVAC compressor outlet (Figure 3, Item 2).

HEATING VENTILATING AND AIR CONDITIONING (HVAC) COMPRESSOR DISCHARGE HOSE REMOVAL AND INSTALLATION - (CONTINUED)

4. Remove heatshrink tubing (Figure 4, Item 3) from compressor discharge hose (Figure 4, Item 2) at t-fitting (Figure 4, Item 1).



B235201643

Figure 4. HVAC Compressor Discharge Hose at T-fitting.

5. Remove HVAC compressor discharge hose (Figure 4, Item 2). Avoid spilling PAG oil. Remove and discard cable lock straps as needed.
6. Drain PAG oil from compressor discharge hose (Figure 4, Item 2) into liquid measure.
7. Remove O-rings from HVAC compressor discharge hose (Figure 4, Item 2). Discard O-rings.

END OF TASK

HEATING VENTILATING AND AIR CONDITIONING (HVAC) COMPRESSOR DISCHARGE HOSE REMOVAL AND INSTALLATION - (CONTINUED)

INSTALLATION

1. Install heat shrink tubing on each end of compressor discharge hose.
2. Coat new O-rings with PAG oil and install one O-ring on each end of HVAC compressor discharge hose.

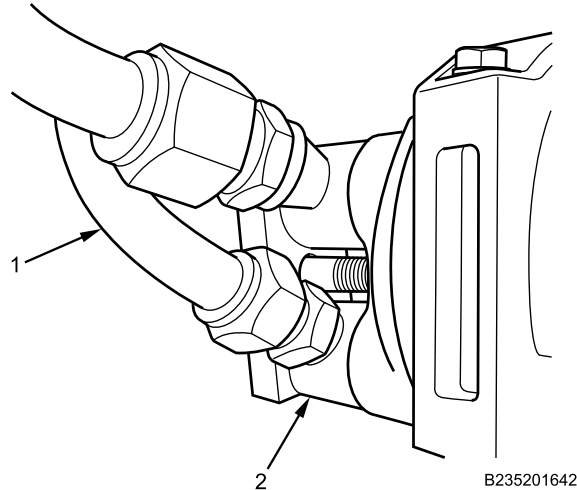
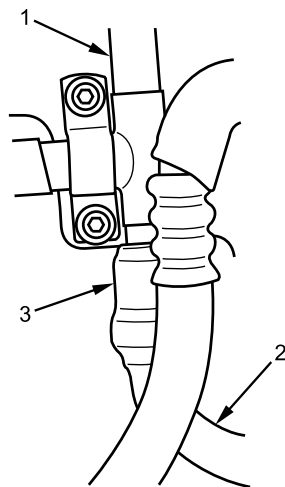

Figure 5. HVAC Compressor Discharge Hose at Compressor.

3. Connect HVAC compressor discharge hose (Figure 5, Item 1) to HVAC compressor outlet (Figure 5, Item 2) and finger-tighten.
4. Add clean PAG oil, equal to amount drained from compressor discharge hose, to end of compressor discharge hose at tee.



B235201643

Figure 6. HVAC Compressor Discharge Hose at T-fitting.

5. Connect HVAC compressor discharge hose (Figure 6, Item 2) to t-fitting (Figure 6, Item 1) and finger-tighten.
6. Tighten HVAC compressor discharge hose fittings securely.

HEATING VENTILATING AND AIR CONDITIONING (HVAC) COMPRESSOR DISCHARGE HOSE REMOVAL AND INSTALLATION - (CONTINUED)

WARNING



Never use open flame to apply heat to heatshrink tubing. Allow heatshrink tubing to cool before handling. Failure to comply may result in serious injury to personnel.

7. Apply heat to heat shrink tubing (Figure 7, Item 2) at compressor discharge outlet until secure over hose (Figure 7, Item 1) and fitting.

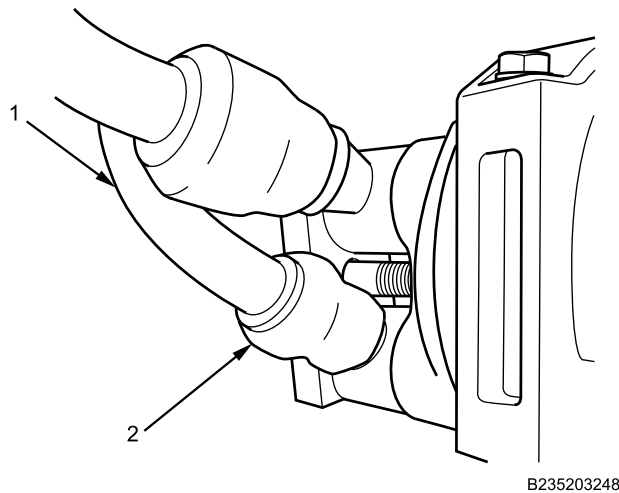

Figure 7. Compressor Discharge Outlet Heat Shrink Tubing

8. Apply heat to heat shrink tubing (Figure 8, Item 3) at tee until secure over hose (Figure 8, Item 2) and fitting.

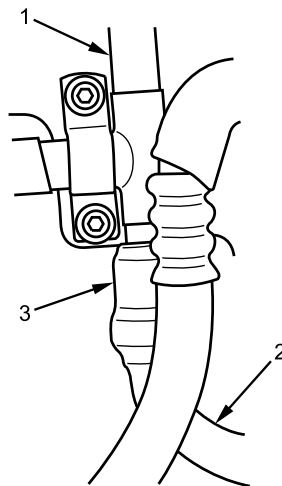
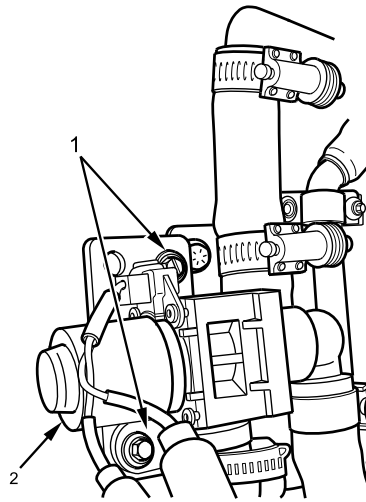

Figure 8. HVAC Compressor Discharge Hose at Tee.

9. Install new cable lock straps where removed.

HEATING VENTILATING AND AIR CONDITIONING (HVAC) COMPRESSOR DISCHARGE HOSE REMOVAL AND INSTALLATION - (CONTINUED)

10. Install 3-way valve (Figure 9, Item 2) with two screws and flat washers (Figure 9, Item 1) and tighten securely.



B235202896

Figure 9. 3-Way Valve.

11. Install all cable lock straps and tighten securely.

END OF TASK**FOLLOW-ON MAINTENANCE**

1. Evacuate and recharge HVAC system (WP 0707).
2. Close and secure engine hood (TM 9-2355-106-10).
3. Remove wheel chocks (TM 9-2355-106-10).

END OF TASK**END OF WORK PACKAGE**

FIELD MAINTENANCE**HEATING VENTILATING AND AIR CONDITIONING (HVAC) SERVICE PORT/SCHRADER VALVE REMOVAL
AND INSTALLATION**

INITIAL SETUP:**Tools and Special Tools**

Refrigeration Ordnance Service Tool Kit
(WP 0795, Item 85)
Gloves, rubber (WP 0795, Item 38)

WP 0782

Materials/Parts

Faceshield, industrial (WP 0794, Item 16)
Lubricating oil (WP 0794, Item 31)

Equipment Condition

Parking brake set (TM 9-2355-106-10)
Transmission set in NEUTRAL (N) (TM
9-2355-106-10)
Engine off (TM 9-2355-106-10)
MAIN POWER switch off (TM 9-2355-106-10)
Wheels chocked (TM 9-2355-106-10)
Engine hood open and secured (TM 9-2355-106-10)
HVAC system refrigerant recovered (WP 0707)

References

TM 9-2355-106-10
TM 9-2355-106-23P

HEATING VENTILATING AND AIR CONDITIONING (HVAC) SERVICE PORT/SCHRADER VALVE REMOVAL AND INSTALLATION - (CONTINUED)

WARNING

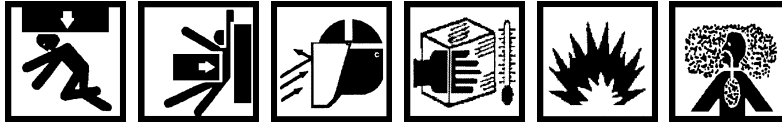

Federal and state laws require that refrigerant be recovered and recycled. Refrigerant must be recovered from system with authorized recommended equipment before any work can be performed on unit. Always use approved recycling equipment to prevent accidental discharge. Failure to comply may result in damage to equipment and environment, and serious injury or death to personnel.

Accidental or intentional introduction of liquid contaminants into the environment is a violation of state, federal, and military regulations. Store, install, and dispose of containers in accordance with standard operating procedures. Refer to Army POL (para. 1-8) for information concerning storage, use, and disposal of liquid contaminants. Failure to comply may result in damage to environment and serious injury or death to personnel.

Engine hood is extremely heavy and requires two-person lift. Ensure that there is adequate space in front of the vehicle to open hood completely without pinning or pinching personnel between hood and any other structure. Use extreme care when working under hood and make sure it is properly supported. Failure to comply may result in serious injury or death to personnel.

The temperature of liquid refrigerant is -20°F (-29°C). Wear full face shield, protective rubberized gloves, and protective clothing when working with refrigerant. If refrigerant contacts skin, remove all contaminated clothing. Treat skin as though it were frostbitten or frozen and seek immediate medical attention. If refrigerant contacts eyes, do not rub them. Flush eyes with cold water for at least 15 minutes to gradually increase temperature above freezing point. Seek immediate medical attention. Failure to comply may result in serious injury or death to personnel.

Do not expose refrigerant containers, empty or full, to open flames or temperatures above 125°F (52°C). Do not discard empty containers where they may be subject to heat from a trash burner; containers may explode. Failure to comply may result in damage to equipment and serious injury or death to personnel.

Do not install or remove air-conditioning testing or charging equipment while engine is running. Wait 30 seconds after engine shutdown to allow high side and low side pressures to equalize. Failure to comply may result in damage to equipment and environment, and serious injury or death to personnel.

R-134a refrigerant must not be mixed with air and then pressurized. When mixed with large quantities of air and pressurized, R-134a becomes combustible. Failure to comply may result in damage to equipment and environment, and serious injury or death to personnel.

Refrigerant evaporates very quickly and may displace oxygen in surrounding work area, especially in a small or enclosed area. This can cause suffocation or brain damage. If leak occurs, avoid breathing refrigerant vapor and thoroughly ventilate area before continuing service. If personnel breathe refrigerant vapors, obtain immediate medical assistance. Failure to comply may result in serious injury or death to personnel.

HEATING VENTILATING AND AIR CONDITIONING (HVAC) SERVICE PORT/SCHRADER VALVE REMOVAL AND INSTALLATION - (CONTINUED)

Refrigerant becomes a poisonous gas in the presence of heat. Do not smoke or allow any type of flame in immediate area while servicing air conditioning system. Never weld, solder, steam clean, or use excessive heat on any part of the air conditioning system while charged/pressurized. Failure to comply may result in damage to equipment and serious injury or death to personnel.

Do not check compressor oil level when HVAC system is charged with refrigerant. Never open the high side hand valve of the manifold gauge set while HVAC system is operating. If hot, high pressure refrigerant is forced through gauge to refrigerant supply cylinder, which could rupture. Do not disconnect HVAC lines from compressor. Release of refrigerant may cause damage to equipment or environment and serious injury or death to personnel.

Do not use parts other than those specified for the system being serviced. Failure to comply may result in damage to equipment and serious injury or death to personnel.

Accidental or intentional introduction of liquid contaminants into the environment is a violation of state, federal, and military regulations. Store, install, and dispose of containers in accordance with standard operating procedures. Refer to Army POL (para. 1-8) for information concerning storage, use, and disposal of liquid contaminants. Failure to comply may result in damage to environment and serious injury or death to personnel.

REMOVAL

WARNING

Do not remove Schrader valve if HVAC system is charged with refrigerant. Removing Schrader valve in charged HVAC systems will cause a sudden release of high pressure refrigerant. Failure to comply may result in damage to equipment and serious injury or death to personnel.

NOTE

This procedure applies to either high-side or low-side service ports.

1. Remove protective cap (Figure 1, Item 3) from service port (Figure 1, Item 1).

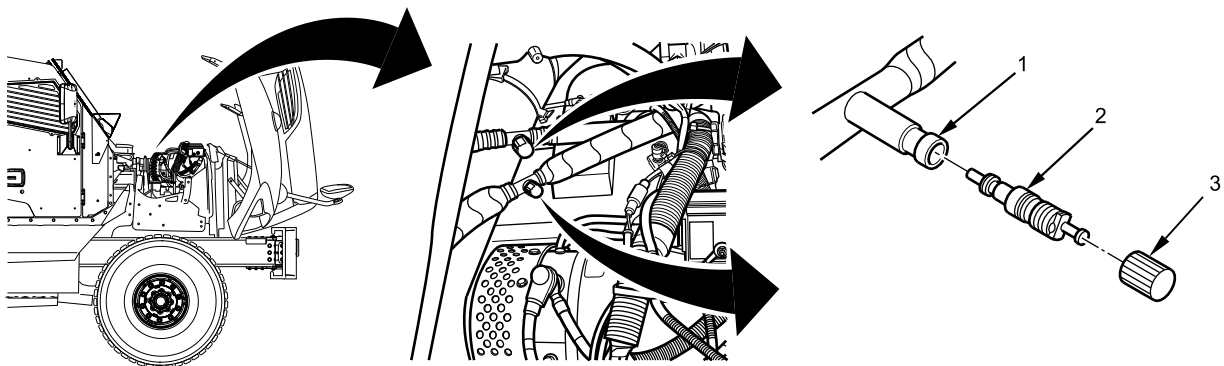

B232212040

Figure 1. HVAC Service Port.

HEATING VENTILATING AND AIR CONDITIONING (HVAC) SERVICE PORT/SCHRADER VALVE REMOVAL AND INSTALLATION - (CONTINUED)

2. Using core removal tool, turn Schrader valve core (Figure 1, Item 2) counterclockwise and remove from service port (Figure 1, Item 1).

END OF TASK

HEATING VENTILATING AND AIR CONDITIONING (HVAC) SERVICE PORT/SCHRADER VALVE REMOVAL AND INSTALLATION - (CONTINUED)

INSTALLATION

CAUTION

Do not drop or allow Schrader valve to come in contact with dirt or sand. Failure to comply may contaminate HVAC system and result in damage to HVAC components.

NOTE

This procedure applies to either high-side or low-side service ports.

1. Coat Schrader valve core (Figure 2, Item 2) with PAG oil.

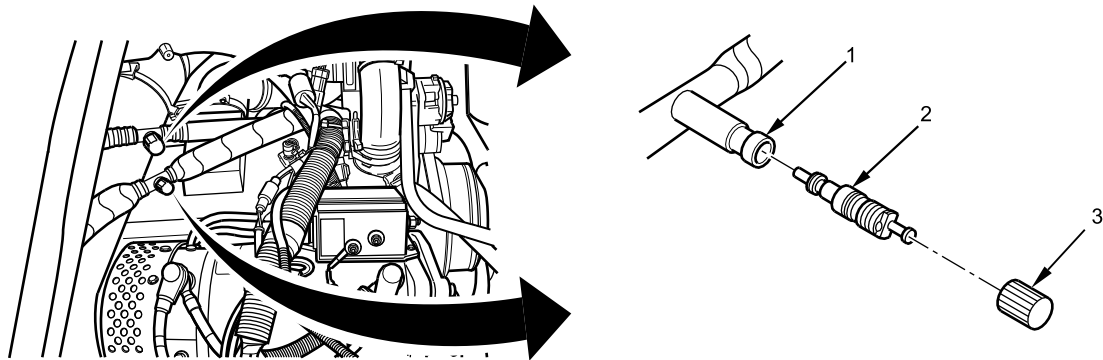

B232212039

Figure 2. HVAC Service Port.

2. Insert Schrader valve core (Figure 2, Item 2) in service port (Figure 2, Item 1).
3. Using core removal tool, turn Schrader valve core clockwise and tighten securely.
4. Install and tighten protective cap (Figure 2, Item 3) on service port (Figure 2, Item 1).

END OF TASK

FOLLOW-ON MAINTENANCE

1. Evacuate and recharge HVAC system (WP 0707).
2. Engine hood closed and secured (TM 9-2355-106-10).
3. Remove wheel chocks (TM 9-2355-106-10).

END OF TASK

END OF WORK PACKAGE

FIELD MAINTENANCE

HEATING VENTILATING AND AIR CONDITIONING (HVAC) WATER DRAINAGE HOSE REMOVAL AND INSTALLATION

INITIAL SETUP:

Tools and Special Tools

General Mechanic's Tool Kit (GMTK)
(WP 0795, Item 37)

WP 0786

WP 0782

Materials/Parts

Clamp - (2) (WP 0796, Item 44)

Equipment Condition

Parking brake set (TM 9-2355-106-10)

Transmission set in NEUTRAL (N) (TM 9-2355-106-10)

Engine off (TM 9-2355-106-10)

MAIN POWER switch off (TM 9-2355-106-10)

Wheels chocked (TM 9-2355-106-10)

References

TM 9-2355-106-10

TM 9-2355-106-23P

REMOVAL

1. Loosen clamp (Figure 1, Item 1) and remove hose (Figure 1, Item 3) from drain fitting (Figure 1, Item 2).

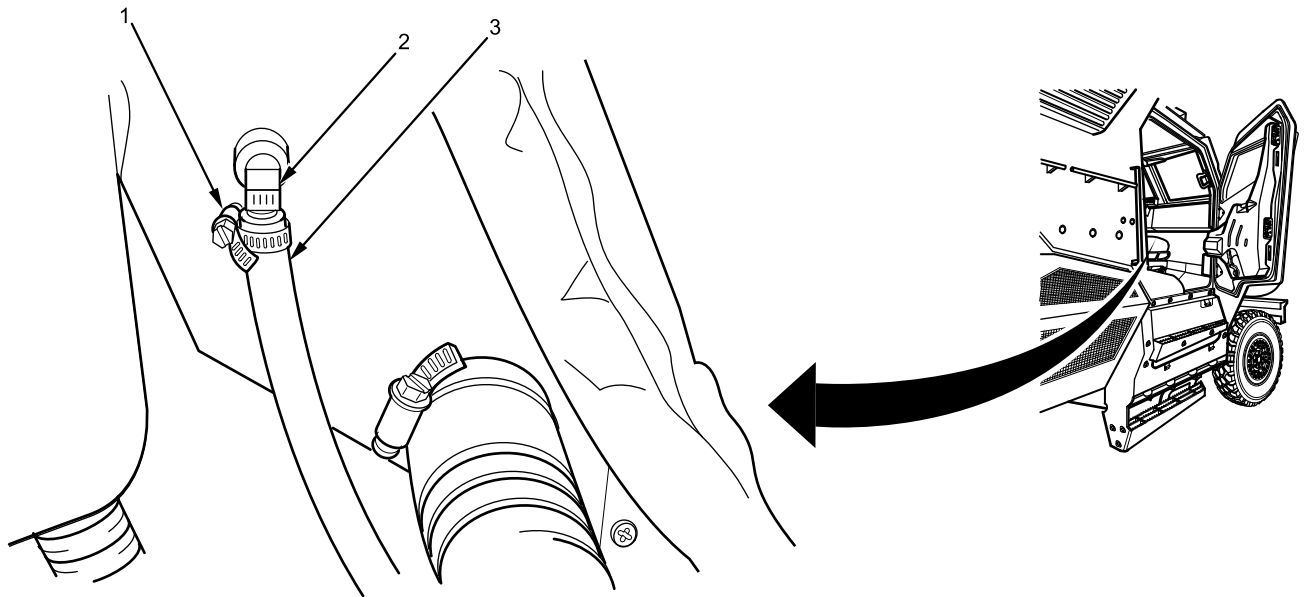

B235210594

Figure 1. HVAC Water Drainage Hose Upper End.

2. Loosen clamp (Figure 2, Item 2) and remove hose (Figure 2, Item 1) from drain fitting (Figure 2, Item 3).

HEATING VENTILATING AND AIR CONDITIONING (HVAC) WATER DRAINAGE HOSE REMOVAL AND INSTALLATION - (CONTINUED)

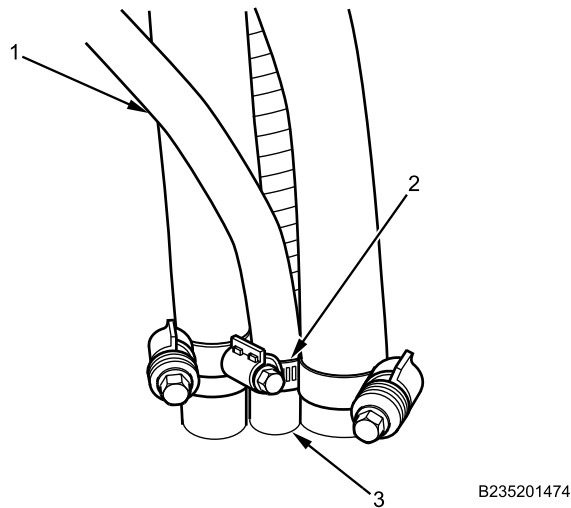

Figure 2. HVAC Water Drainage Hose Lower End.

3. Discard clamps (Figure 2, Item 1) and (Figure 2, Item 2).

END OF TASK

INSTALLATION

1. Position new clamp (Figure 3, Item 1) on hose (Figure 3, Item 3).

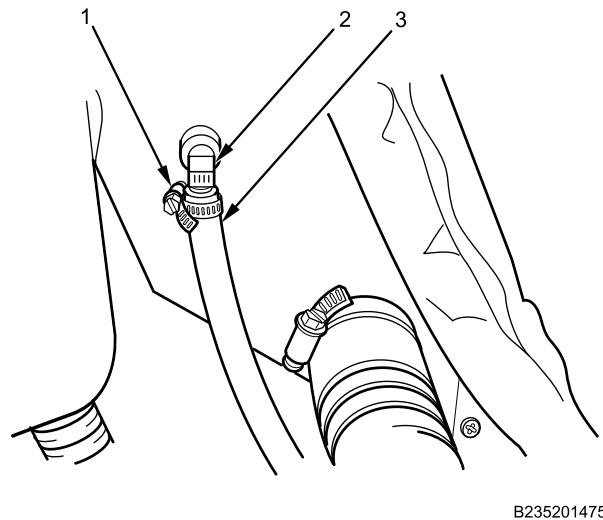

Figure 3. HVAC Water Drainage Hose Upper End.

2. Install hose (Figure 3, Item 3) on drain fitting (Figure 3, Item 2) and tighten clamp (Figure 3, Item 1) securely.
3. Position new clamp (Figure 4, Item 2) on hose (Figure 4, Item 1).

HEATING VENTILATING AND AIR CONDITIONING (HVAC) WATER DRAINAGE HOSE REMOVAL AND INSTALLATION - (CONTINUED)

Figure 4. HVAC Water Drainage Hose Lower End.

4. Install hose (Figure 4, Item 1) on drain fitting (Figure 4, Item 3) and tighten clamp (Figure 4, Item 2) securely.

END OF TASK**FOLLOW-ON MAINTENANCE**

1. Turn MAIN POWER switch on (TM 9-2355-106-10).
2. Start engine (TM 9-2355-106-10).
3. Check for leaks.
4. Turn engine off (TM 9-2355-106-10).
5. Turn MAIN POWER switch off (TM 9-2355-106-10).
6. Remove wheel chocks (TM 9-2355-106-10).

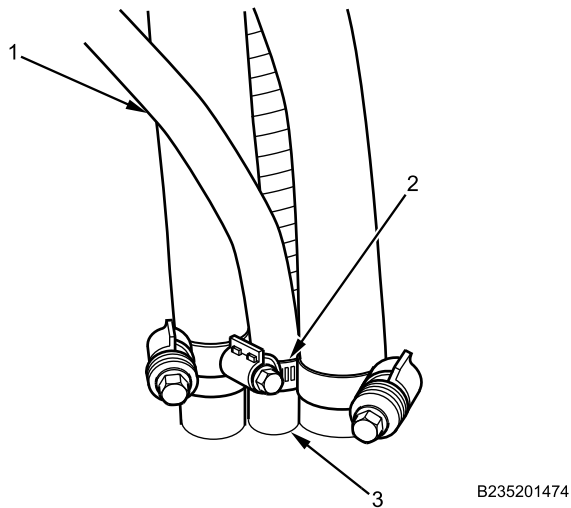
END OF TASK**END OF WORK PACKAGE**

FIELD MAINTENANCE**HEATING VENTILATING AND AIR CONDITIONING (HVAC) FRESH AIR INLET TUBE REMOVAL AND INSTALLATION****INITIAL SETUP:****Tools and Special Tools**

General Mechanic's Tool Kit (GMTK)
(WP 0795, Item 37)

References

TM 9-2355-106-10
TM 9-2355-106-23P
WP 0786
WP 0782

Equipment Condition

Parking brake set (TM 9-2355-106-10)
Transmission set in NEUTRAL (N) (TM
9-2355-106-10)
Engine off (TM 9-2355-106-10)
MAIN POWER switch off (TM 9-2355-106-10)
Wheels chocked (TM 9-2355-106-10)

REMOVAL

1. Loosen two hose clamps (Figure 1, Item 3) on fresh air inlet tube (Figure 1, Item 1).

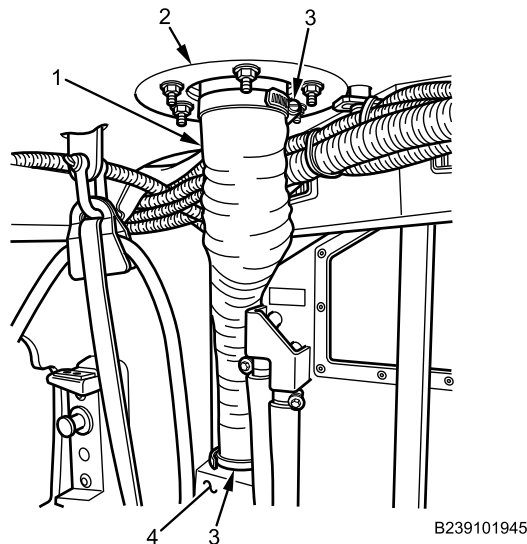

Figure 1. Fresh Air Inlet Tube.

2. Remove fresh air inlet tube (Figure 1, Item 1) from fresh air inlet flange (Figure 1, Item 2) and HVAC/Life Support System (LSS) box (Figure 1, Item 4).
3. Remove two hose clamps (Figure 1, Item 3) from fresh air inlet tube (Figure 1, Item 1).

END OF TASK

HEATING VENTILATING AND AIR CONDITIONING (HVAC) FRESH AIR INLET TUBE REMOVAL AND INSTALLATION - (CONTINUED)**INSTALLATION**

1. Install hose clamps (Figure 2, Item 3) on fresh air inlet tube (Figure 2, Item 1). Do not tighten.

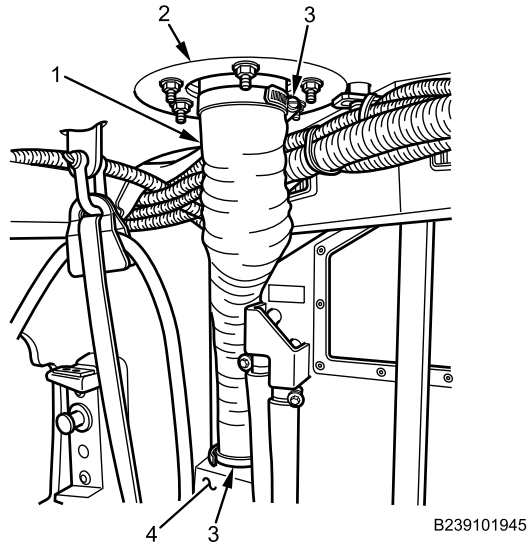

Figure 2. Fresh Air Inlet Tube.

2. Position fresh air inlet tube (Figure 2, Item 1) on fresh air inlet flange (Figure 2, Item 2). Do not tighten.
3. Position air inlet tube (Figure 2, Item 1) on HVAC/LSS box (Figure 2, Item 4).
4. Tighten two hose clamps (Figure 2, Item 3) securely.

END OF TASK**FOLLOW-ON MAINTENANCE**

1. Remove wheel chocks (TM 9-2355-106-10).

END OF TASK**END OF WORK PACKAGE**

FIELD MAINTENANCE**NUCLEAR, BIOLOGICAL, AND CHEMICAL (NBC) DUST TUBE REMOVAL AND INSTALLATION**

INITIAL SETUP:**Tools and Special Tools**

General Mechanic's Tool Kit (GMTK)
(WP 0795, Item 37)

Personnel Required

Maintainer - (2)

References

TM 9-2355-106-10
TM 9-2355-106-23P
WP 0786

WP 0782

Equipment Condition

Parking brake set (TM 9-2355-106-10)
Transmission set in NEUTRAL (N) (TM
9-2355-106-10)
Engine off (TM 9-2355-106-10)
MAIN POWER switch off (TM 9-2355-106-10)
Wheels chocked (TM 9-2355-106-10)
Life Support System (LSS) control switch off (TM
9-2355-106-10)

WARNING

NBC system maintenance procedures require at least two personnel due to risk of medical emergency from possible exposure to NBC agents. Maintenance must be performed by properly trained, authorized personnel with proper safety equipment and protective clothing. Make sure batteries are disconnected and area is well ventilated. Do not smoke or allow open flame near vehicle. Never operate system with cover or panel removed. Failure to comply may result in serious injury or death to personnel.

NUCLEAR, BIOLOGICAL, AND CHEMICAL (NBC) DUST TUBE REMOVAL AND INSTALLATION - (CONTINUED)

REMOVAL

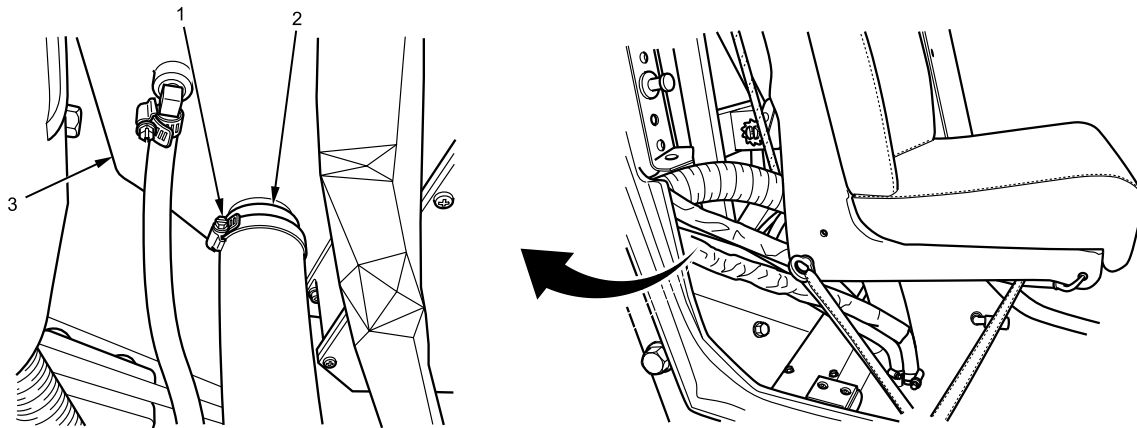

B239103402

Figure 1. External Dust Tube at Forward Side of Heating Ventilating and Air Conditioning (HVAC)/Life Support System (LSS) Box.

NOTE

Dust tubes are routed from forward side of HVAC box, behind and under right front passenger seat.

1. Loosen hose clamp (Figure 1, Item 1) from external dust tube (Figure 1, Item 2) at HVAC box (Figure 1, Item 3).
2. Pull external dust tube (Figure 1, Item 2) away from connection on HVAC/LSS box (Figure 1, Item 3).

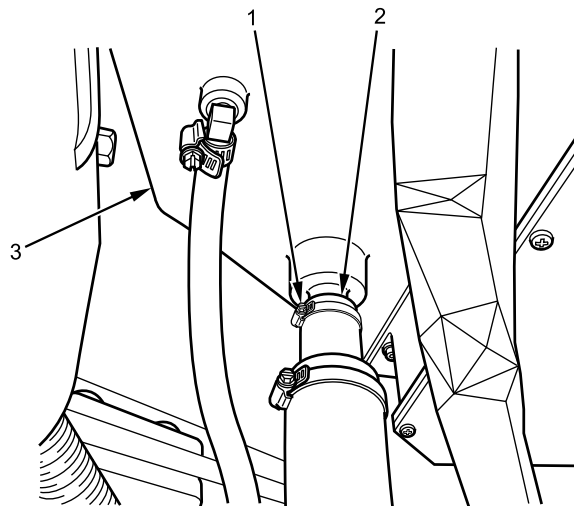

B239102036

Figure 2. Dust Tube at Forward Side of HVAC/LSS Box.

3. Loosen hose clamp (Figure 2, Item 1) from dust tube (Figure 2, Item 2).
4. Remove dust tube (Figure 2, Item 2) from connection on HVAC/LSS box (Figure 2, Item 3).

NUCLEAR, BIOLOGICAL, AND CHEMICAL (NBC) DUST TUBE REMOVAL AND INSTALLATION - (CONTINUED)

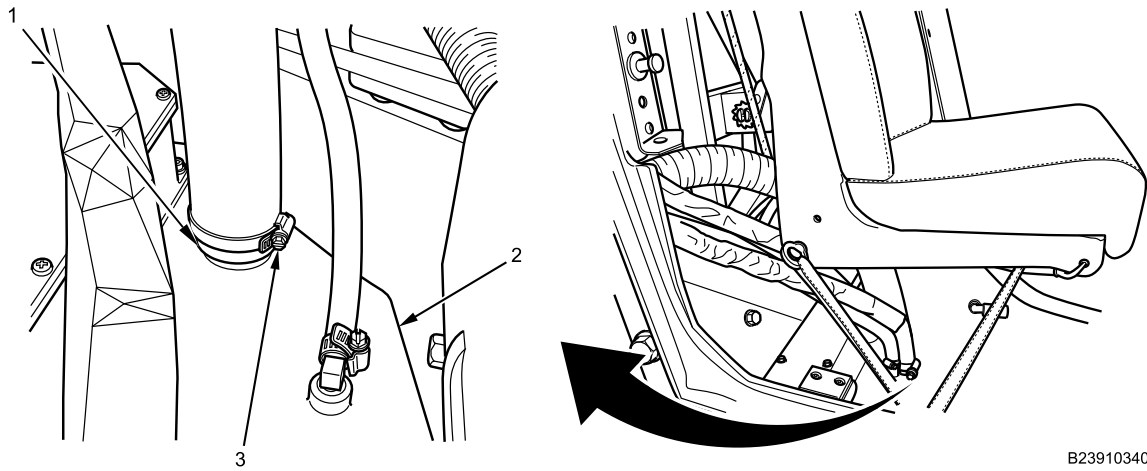

B239103403

Figure 3. External Dust Tube at Floor Under Right Front Seat.

5. Loosen hose clamp (Figure 3, Item 3) from external dust tube (Figure 3, Item 2).
6. Pull external dust tube (Figure 3, Item 2) from connection on floor (Figure 3, Item 1).

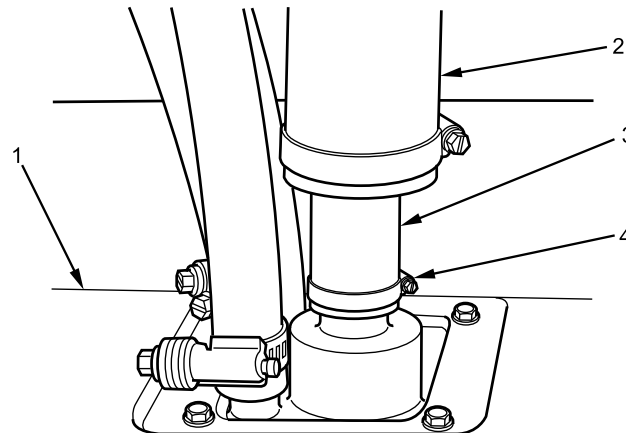

B239102038

Figure 4. Dust Tube at Floor Under Right Front Seat.

7. Remove external dust tube (Figure 4, Item 2) from dust tube (Figure 4, Item 3).
8. Loosen hose clamp (Figure 4, Item 4) from dust tube (Figure 4, Item 3).
9. Remove dust tube (Figure 4, Item 3) from connection on floor (Figure 4, Item 1).

END OF TASK

NUCLEAR, BIOLOGICAL, AND CHEMICAL (NBC) DUST TUBE REMOVAL AND INSTALLATION - (CONTINUED)

INSTALLATION

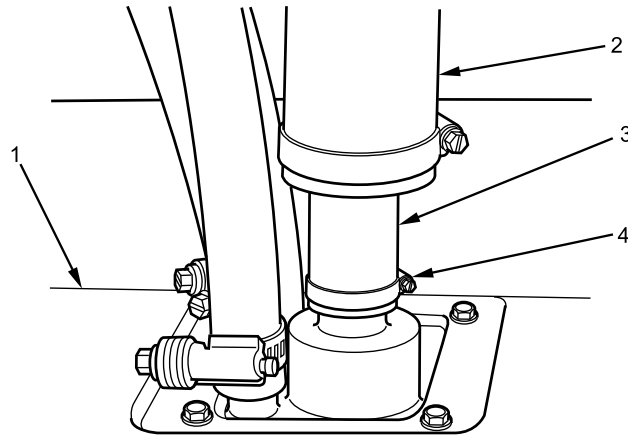

B239102038

Figure 5. Dust Tube at Floor Under Right Front Seat.

NOTE

Dust tubes are routed from forward side of HVAC box, behind and under right front passenger seat.

1. Install dust tube (Figure 5, Item 3) on connection at floor (Figure 5, Item 1) with hose clamp (Figure 5, Item 4) and tighten securely.
2. Slide external dust tube (Figure 5, Item 2) over dust tube (Figure 5, Item 3).

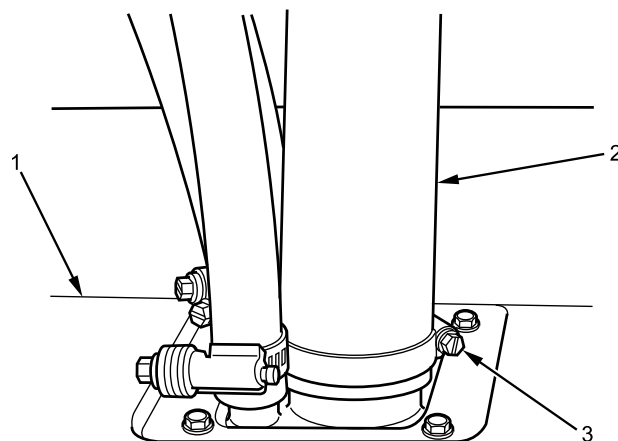

B239102037

Figure 6. External Dust Tube at Floor Under Right Front Seat.

3. Install external dust tube (Figure 6, Item 2) on connection at floor (Figure 6, Item 1) with hose clamp (Figure 6, Item 3) and tighten securely.

**NUCLEAR, BIOLOGICAL, AND CHEMICAL (NBC) DUST TUBE REMOVAL AND INSTALLATION -
(CONTINUED)**

Figure 7. Dust Tube at Forward Side of HVAC/LSS Box.

4. Install dust tube (Figure 7, Item 2) on connection at HVAC/LSS box (Figure 7, Item 3) with hose clamp (Figure 7, Item 1) and tighten securely.

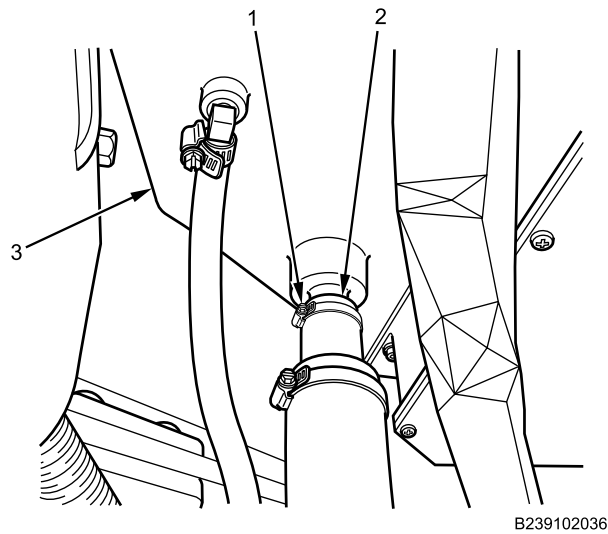
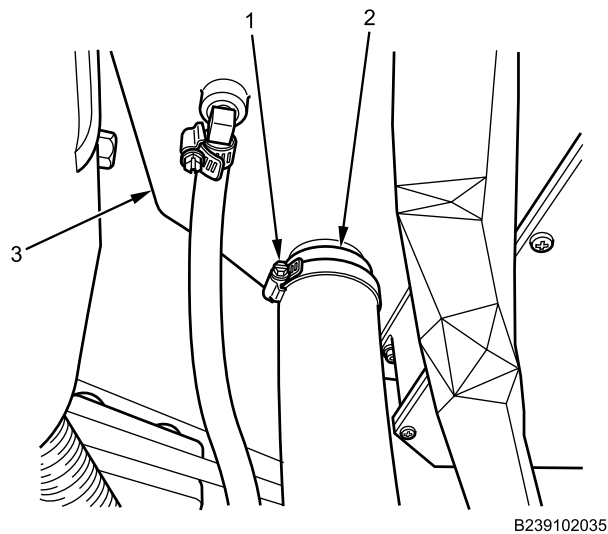

Figure 8. External Dust Tube at Forward Side of HVAC/LSS Box.

5. Install external dust tube (Figure 8, Item 2) on connection at HVAC/LSS box (Figure 8, Item 3) with hose clamp (Figure 8, Item 1) and tighten securely.

END OF TASK

**NUCLEAR, BIOLOGICAL, AND CHEMICAL (NBC) DUST TUBE REMOVAL AND INSTALLATION -
(CONTINUED)****FOLLOW-ON MAINTENANCE**

1. Turn MAIN POWER switch on (TM 9-2355-106-10).
2. Start engine (TM 9-2355-106-10).
3. Turn on HVAC/LSS (TM 9-2355-106-10).
4. Check dust tube for air leaks.
5. Turn off HVAC/LSS (TM 9-2355-106-10).
6. Turn engine off (TM 9-2355-106-10).
7. Turn MAIN POWER switch off (TM 9-2355-106-10).
8. Remove wheel chocks (TM 9-2355-106-10).

END OF TASK**END OF WORK PACKAGE**

FIELD MAINTENANCE
HEATING VENTILATING AND AIR CONDITIONING (HVAC) REFRIGERANT FILTER REMOVAL AND INSTALLATION

INITIAL SETUP:**Tools and Special Tools**

General Mechanic's Tool Kit (GMTK)
 (WP 0795, Item 37)
 Gloves, rubber (WP 0795, Item 38)
 Cap and Plug Set (WP 0795, Item 23)

TM 9-2355-106-23P

WP 0786

WP 0782

Materials/Parts

Lubricating oil (WP 0794, Item 31)
 Faceshield, industrial (WP 0794, Item 16)
 O-ring (WP 0796, Item 35)
 O-ring - (2) (WP 0796, Item 34)

Equipment Condition

Parking brake set (TM 9-2355-106-10)

Transmission set in NEUTRAL (N) (TM 9-2355-106-10)

Engine off (TM 9-2355-106-10)

MAIN POWER switch off (TM 9-2355-106-10)

Wheels chocked (TM 9-2355-106-10)

Engine hood open and secured (TM 9-2355-106-10)

Right side engine armor plate removed (WP 0599)

HVAC system refrigerant recovered (WP 0707)

References

TM 9-2355-106-10

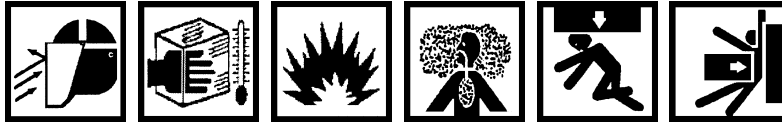
HEATING VENTILATING AND AIR CONDITIONING (HVAC) REFRIGERANT FILTER REMOVAL AND INSTALLATION - (CONTINUED)**WARNING**

Federal and state laws require that refrigerant be recovered and recycled. Refrigerant must be recovered from system with authorized recommended equipment before any work can be performed on unit. Always use approved recycling equipment to prevent accidental discharge. Failure to comply may result in damage to equipment and environment, and serious injury or death to personnel.

Do not install or remove air-conditioning testing or charging equipment while engine is running. Wait 30 seconds after engine shutdown to allow high side and low side pressures to equalize. Failure to comply may result in damage to equipment and environment, and serious injury or death to personnel.

The temperature of liquid refrigerant is -20°F (-29°C). Wear full face shield, protective rubberized gloves, and protective clothing when working with refrigerant. If refrigerant contacts skin, remove all contaminated clothing. Treat skin as though it were frostbitten or frozen and seek immediate medical attention. If refrigerant contacts eyes, do not rub them. Flush eyes with cold water for at least 15 minutes to gradually increase temperature above freezing point. Seek immediate medical attention. Failure to comply may result in serious injury or death to personnel.

Do not expose refrigerant containers, empty or full, to open flames or temperatures above 125°F (52°C). Do not discard empty containers where they may be subject to heat from a trash burner; containers may explode. Failure to comply may result in damage to equipment and serious injury or death to personnel.

Engine hood is extremely heavy and requires two-person lift. Ensure that there is adequate space in front of the vehicle to open hood completely without pinning or pinching personnel between hood and any other structure. Use extreme care when working under hood and make sure it is properly supported. Failure to comply may result in serious injury or death to personnel.

R-134a refrigerant must not be mixed with air and then pressurized. When mixed with large quantities of air and pressurized, R-134a becomes combustible. Failure to comply may result in damage to equipment and environment, and serious injury or death to personnel.

Refrigerant evaporates very quickly and may displace oxygen in surrounding work area, especially in a small or enclosed area. This can cause suffocation or brain damage. If leak occurs, avoid breathing refrigerant vapor and thoroughly ventilate area before continuing service. If personnel breathe refrigerant vapors, obtain immediate medical assistance. Failure to comply may result in serious injury or death to personnel.

Refrigerant becomes a poisonous gas in the presence of heat. Do not smoke or allow any type of flame in immediate area while servicing air conditioning system. Never weld, solder, steam clean, or use excessive heat on any part of the air conditioning system while charged/pressurized. Failure to comply may result in damage to equipment and serious injury or death to personnel.

HEATING VENTILATING AND AIR CONDITIONING (HVAC) REFRIGERANT FILTER REMOVAL AND INSTALLATION - (CONTINUED)

Do not check compressor oil level when HVAC system is charged with refrigerant. Never open the high side hand valve of the manifold gauge set while HVAC system is operating. If hot, high pressure refrigerant is forced through gauge to refrigerant supply cylinder, which could rupture. Do not disconnect HVAC lines from compressor. Release of refrigerant may cause damage to equipment or environment and serious injury or death to personnel.

Do not use parts other than those specified for the system being serviced. Failure to comply may result in damage to equipment and serious injury or death to personnel.

Accidental or intentional introduction of liquid contaminants into the environment is a violation of state, federal, and military regulations. Store, install, and dispose of containers in accordance with standard operating procedures. Refer to Army POL (para. 1-8) for information concerning storage, use, and disposal of liquid contaminants. Failure to comply may result in damage to environment and serious injury or death to personnel.

REMOVAL

CAUTION

Do not allow dirt to contaminate HVAC lines or HVAC filter. Failure to comply may result in damage to HVAC components and equipment.

1. Remove and discard heatshrink tubing from three HVAC lines (Figure 1, Item 1).

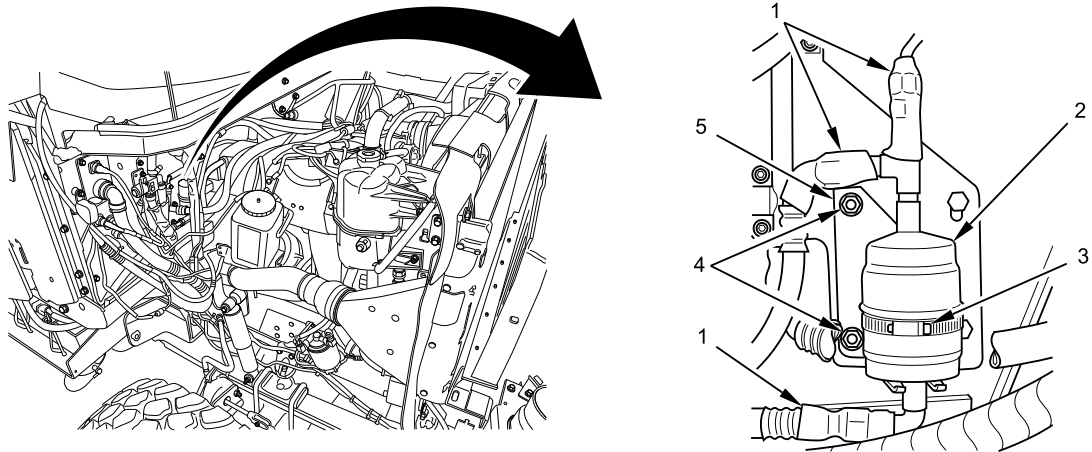

B231810672

Figure 1. HVAC Filter.

2. Disconnect HVAC lines (Figure 1, Item 1) from HVAC filter (Figure 1, Item 2).
3. Cap and plug HVAC lines (Figure 1, Item 1).
4. Loosen filter clamp (Figure 1, Item 3) and remove HVAC filter (Figure 1, Item 2) from bracket (Figure 1, Item 5).
5. Remove two bracket nuts (Figure 1, Item 4) and bracket (Figure 1, Item 5).

HEATING VENTILATING AND AIR CONDITIONING (HVAC) REFRIGERANT FILTER REMOVAL AND INSTALLATION - (CONTINUED)

6. Remove O-rings (Figure 2, Item 2) from ends of HVAC lines (Figure 2, Item 1). Discard O-rings.

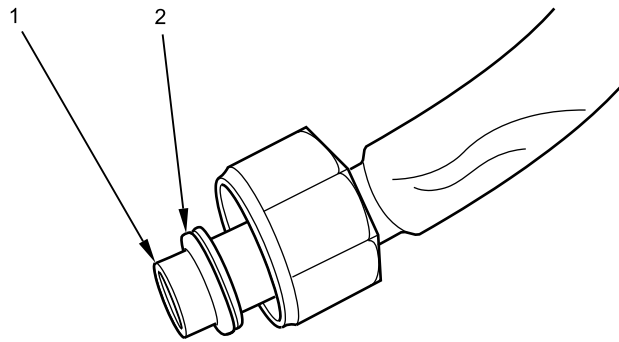

B235203067

Figure 2. O-Ring Removal.

END OF TASK**INSTALLATION**

1. Coat new O-rings (Figure 3, Item 2) with PAG oil.

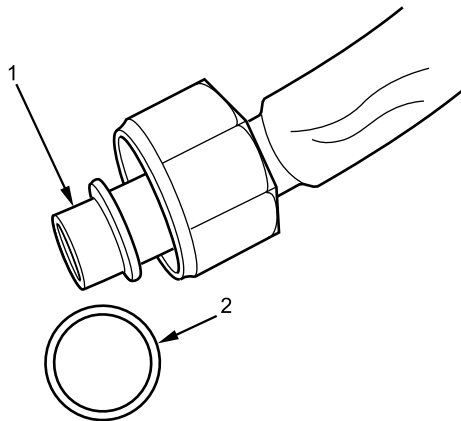

B235203066

Figure 3. O-Ring Installation.

2. Remove cap and plug from ends HVAC lines(Figure 3, Item 1) and install new O-rings(Figure 3, Item 2).

HEATING VENTILATING AND AIR CONDITIONING (HVAC) REFRIGERANT FILTER REMOVAL AND INSTALLATION - (CONTINUED)

3. Install HVAC filter (Figure 4, Item 2) on bracket (Figure 4, Item 5) with filter clamp (Figure 4, Item 3). Tighten filter clamp.

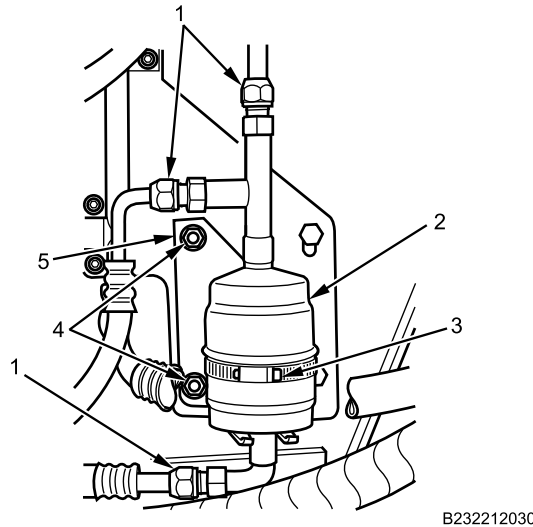

Figure 4. HVAC Filter.

4. Install bracket (Figure 4, Item 5) with two nuts (Figure 4, Item 4). Tighten bracket nuts.
5. Install HVAC lines (Figure 4, Item 1) on HVAC filter and tighten securely.

END OF TASK

FOLLOW-ON MAINTENANCE

1. Evacuate and recharge HVAC system (WP 0707).
2. Install right side engine armor plate (WP 0599).
3. Close and secure engine hood (TM 9-2355-106-10).
4. Remove wheel chocks (TM 9-2355-106-10).

END OF TASK

END OF WORK PACKAGE

FIELD MAINTENANCE**HEATING VENTILATING AND AIR CONDITIONING (HVAC) CONDENSER REMOVAL AND INSTALLATION**

INITIAL SETUP:**Tools and Special Tools**

General Mechanic's Tool Kit (GMTK)
(WP 0795, Item 37)
Gloves, rubber (WP 0795, Item 38)
Cap and Plug Set (WP 0795, Item 23)

TM 9-2355-106-23P

WP 0786

WP 0782

Materials/Parts

Faceshield, industrial (WP 0794, Item 16)
Lubricating oil (WP 0794, Item 31)
Tags (WP 0794, Item 49)
Locknuts - (4) (WP 0796, Item 135)
O-ring - (2) (WP 0796, Item 34)

Equipment Condition

Parking brake set (TM 9-2355-106-10)
Transmission set in NEUTRAL (N) (TM
9-2355-106-10)
Engine off (TM 9-2355-106-10)
MAIN POWER switch off (TM 9-2355-106-10)
Wheels chocked (TM 9-2355-106-10)
Engine hood open and secured (TM 9-2355-106-10)
Air conditioning (A/C) condenser panel removed
(WP 0672)
HVAC system discharged (WP 0707)

Personnel Required

Maintainer (HVAC Certified) - (1)
Maintainer - (1)

ReferencesTM 9-2355-106-10

HEATING VENTILATING AND AIR CONDITIONING (HVAC) CONDENSER REMOVAL AND INSTALLATION - (CONTINUED)

WARNING

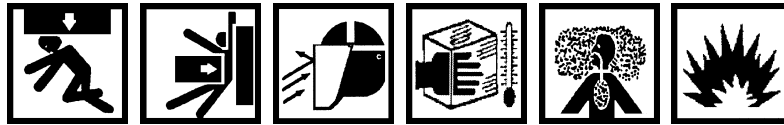

Engine hood is extremely heavy and requires two-person lift. Ensure that there is adequate space in front of the vehicle to open hood completely without pinning or pinching personnel between hood and any other structure. Use extreme care when working under hood and make sure it is properly supported. Failure to comply may result in serious injury or death to personnel.

Do not install or remove air-conditioning testing or charging equipment while engine is running. Wait 30 seconds after engine shutdown to allow high side and low side pressures to equalize. Failure to comply may result in damage to equipment and environment, and serious injury or death to personnel.

Never open the high side hand valve of the manifold gauge set while HVAC system is operating. If hot, high pressure refrigerant is forced through gauge to refrigerant supply cylinder, which could rupture. Failure to comply may result in damage to equipment and environment, and serious injury or death to personnel.

The temperature of liquid refrigerant is -20°F (-29°C). Wear full face shield, protective rubberized gloves, and protective clothing when working with refrigerant. If refrigerant contacts skin, remove all contaminated clothing. Treat skin as though it were frostbitten or frozen and seek immediate medical attention. If refrigerant contacts eyes, do not rub them. Flush eyes with cold water for at least 15 minutes to gradually increase temperature above freezing point. Seek immediate medical attention. Failure to comply may result in serious injury or death to personnel.

Do not expose refrigerant containers, empty or full, to open flames or temperatures above 125°F (52°C). Do not discard empty containers where they may be subject to heat from a trash burner; containers may explode. Failure to comply may result in damage to equipment and serious injury or death to personnel.

Never open the high side hand valve of the manifold gauge set while HVAC system is operating. If hot, high pressure refrigerant is forced through gauge to refrigerant supply cylinder, which could rupture. Failure to comply may result in damage to equipment and environment, and serious injury or death to personnel.

The temperature of liquid refrigerant is -20°F (-29°C). Wear full face shield, protective rubberized gloves, and protective clothing when working with refrigerant. If refrigerant contacts skin, remove all contaminated clothing. Treat skin as though it were frostbitten or frozen and seek immediate medical attention. If refrigerant contacts eyes, do not rub them. Flush eyes with cold water for at least 15 minutes to gradually increase temperature above freezing point. Seek immediate medical attention. Failure to comply may result in serious injury or death to personnel.

Do not expose refrigerant containers, empty or full, to open flames or temperatures above 125°F (52°C). Do not discard empty containers where they may be subject to heat from a trash burner; containers may explode. Failure to comply may result in damage to equipment and serious injury or death to personnel.

HEATING VENTILATING AND AIR CONDITIONING (HVAC) CONDENSER REMOVAL AND INSTALLATION - (CONTINUED)

Refrigerant becomes a poisonous gas in the presence of heat. Do not smoke or allow any type of flame in immediate area while servicing air conditioning system. Never weld, solder, steam clean, or use excessive heat on any part of the air conditioning system while charged/pressurized. Failure to comply may result in damage to equipment and serious injury or death to personnel.

R-134a refrigerant must not be mixed with air and then pressurized. When mixed with large quantities of air and pressurized, R-134a becomes combustible. Failure to comply may result in damage to equipment and environment, and serious injury or death to personnel.

Refrigerant evaporates very quickly and may displace oxygen in surrounding work area, especially in a small or enclosed area. This can cause suffocation or brain damage. If leak occurs, avoid breathing refrigerant vapor and thoroughly ventilate area before continuing service. If personnel breathe refrigerant vapors, obtain immediate medical assistance. Failure to comply may result in serious injury or death to personnel.

Federal and state laws require that refrigerant be recovered and recycled. Refrigerant must be recovered from system with authorized recommended equipment before any work can be performed on unit. Always use approved recycling equipment to prevent accidental discharge. Failure to comply may result in damage to equipment and environment, and serious injury or death to personnel.

Do not check compressor oil level when HVAC system is charged with refrigerant. Never open the high side hand valve of the manifold gauge set while HVAC system is operating. If hot, high pressure refrigerant is forced through gauge to refrigerant supply cylinder, which could rupture. Do not disconnect HVAC lines from compressor. Release of refrigerant may cause damage to equipment or environment and serious injury or death to personnel.

Do not use parts other than those specified for the system being serviced. Failure to comply may result in damage to equipment and serious injury or death to personnel.

Accidental or intentional introduction of liquid contaminants into the environment is a violation of state, federal, and military regulations. Store, install, and dispose of containers in accordance with standard operating procedures. Refer to Army Petroleum, Oil, and Lubricants (POL) (para. 1-8) for information concerning storage, use, and disposal of liquid contaminants. Failure to comply may result in damage to environment and serious injury or death to personnel.

CAUTION

To prevent damage to test equipment, make sure test equipment is clear of all moving parts in the engine compartment. Failure to comply may result in damage to equipment.

NOTE

Left side shown, right side similar.

HEATING VENTILATING AND AIR CONDITIONING (HVAC) CONDENSER REMOVAL AND INSTALLATION - (CONTINUED)

REMOVAL

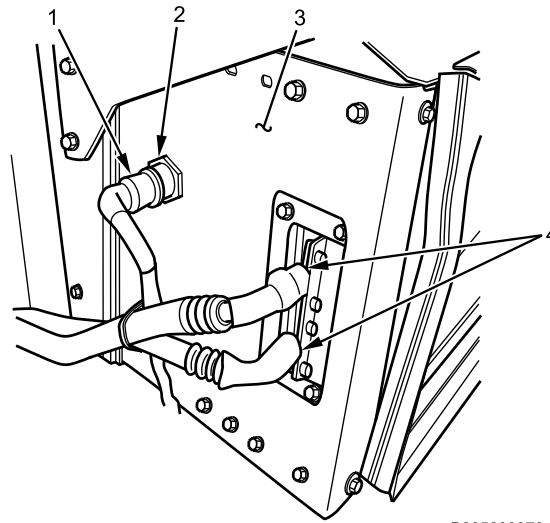

B235203379

Figure 1. HVAC Condenser Lines.

1. Disconnect fan electrical connector (Figure 1, Item 1) from condenser housing (Figure 1, Item 3).
2. Remove fan harness connector retaining nut (Figure 1, Item 2) from condenser housing (Figure 1, Item 3).
3. Remove heatshrink tubing from HVAC lines (Figure 1, Item 4).

NOTE

Ensure to tag HVAC lines prior to removal to aid in installation.

4. Disconnect HVAC lines (Figure 1, Item 4) from HVAC condenser housing (Figure 1, Item 3). Remove and discard O-rings.
5. Cap and plug HVAC lines (Figure 1, Item 4).

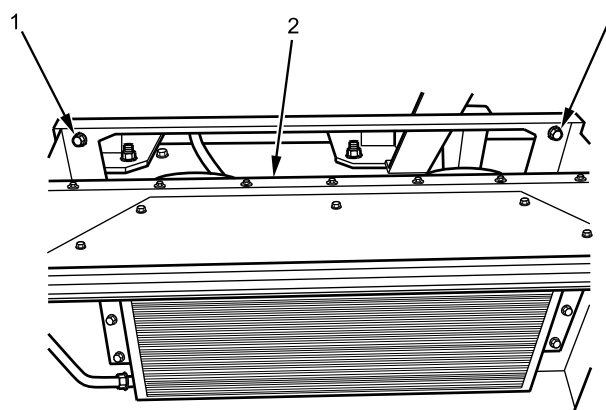

B235201514

Figure 2. HVAC Condenser Unit.

6. Support HVAC condenser unit (Figure 2, Item 2) with straps or stands.

HEATING VENTILATING AND AIR CONDITIONING (HVAC) CONDENSER REMOVAL AND INSTALLATION - (CONTINUED)

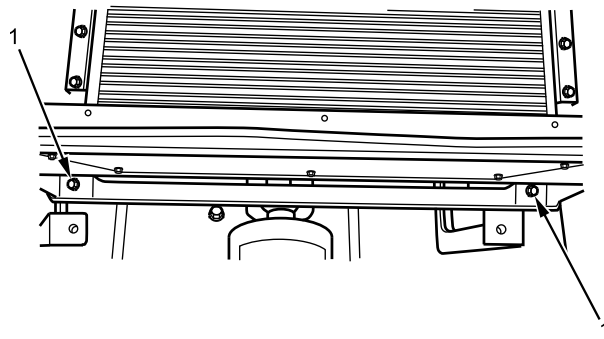

B235201515

Figure 3. HVAC Condenser Unit.

7. Remove four bolts (Figure 2, Item 1)(Figure 3, Item 1), washers, and locknuts attaching HVAC condenser unit (Figure 2, Item 2) to vehicle. Discard locknuts.
8. With assistant, remove HVAC condenser unit (Figure 2, Item 2) and place on flat surface with condenser facing down.

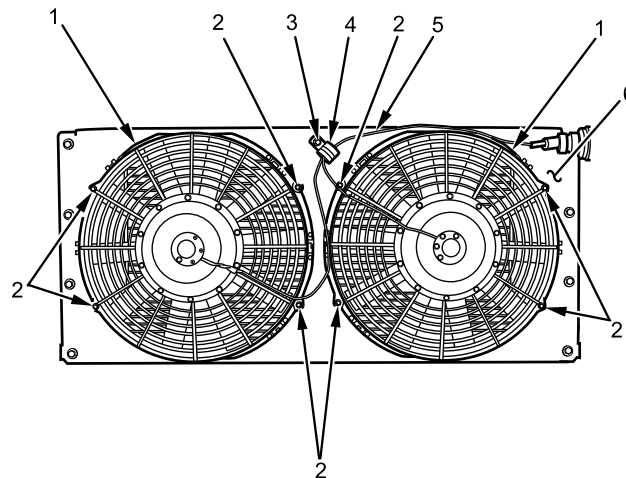

B235203380

Figure 4. HVAC Condenser Fan Assembly.

9. Remove screw (Figure 4, Item 3), lockwasher, washer, and wiring harness clip (Figure 4, Item 4) from condenser unit (Figure 4, Item 6). Discard lockwasher.
10. Remove eight bolts (Figure 4, Item 2), lockwashers, and washers attaching HVAC fans (Figure 4, Item 1) to A/C condenser unit (Figure 4, Item 6). Discard lockwashers.
11. Remove HVAC fans (Figure 4, Item 1) and wiring harness (Figure 4, Item 5) from condenser unit (Figure 4, Item 6).

END OF TASK

HEATING VENTILATING AND AIR CONDITIONING (HVAC) CONDENSER REMOVAL AND INSTALLATION - (CONTINUED)

INSTALLATION

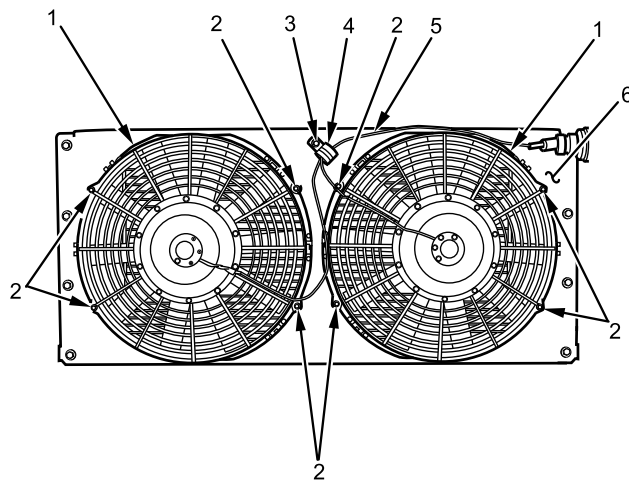

B235203380

Figure 5. HVAC Condenser Fan Assembly.

1. With HVAC condenser unit (Figure 5, Item 6) laying on flat surface, position HVAC fans (Figure 5, Item 1) on HVAC condenser unit.
2. Install HVAC fans (Figure 5, Item 1) on HVAC condenser unit (Figure 5, Item 6) with eight bolts (Figure 5, Item 2), new lockwashers, and washers and tighten bolts securely.
3. Position wiring harness (Figure 5, Item 5) on HVAC condenser unit (Figure 5, Item 6).
4. Install wiring harness clip (Figure 5, Item 4) on condenser unit (Figure 5, Item 6) with screw (Figure 5, Item 3) and tighten securely.

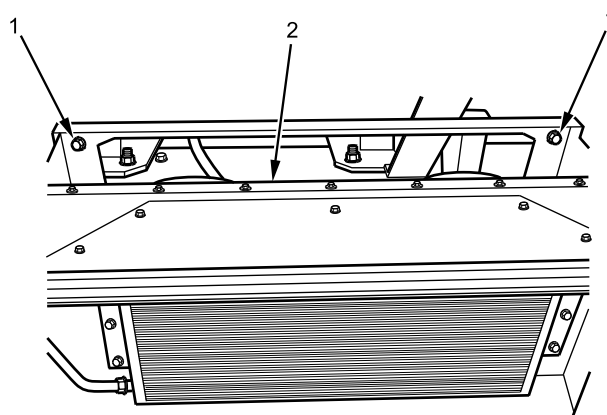

B235201514

Figure 6. HVAC Condenser Unit.

5. With assistant, position HVAC condenser unit (Figure 6, Item 2) on vehicle and support with straps or stands.

HEATING VENTILATING AND AIR CONDITIONING (HVAC) CONDENSER REMOVAL AND INSTALLATION - (CONTINUED)

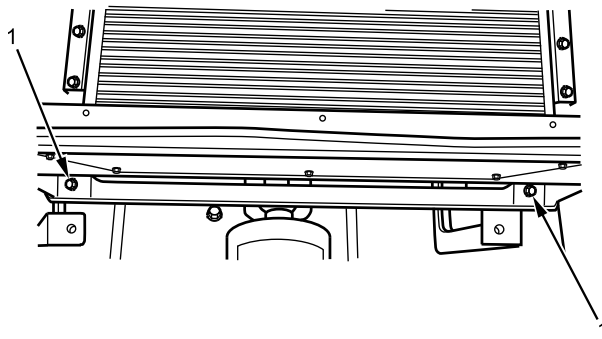

B235201515

Figure 7. HVAC Condenser Unit.

6. Install HVAC condenser unit (Figure 6, Item 2) on vehicle with four bolts (Figure 6, Item 1) and (Figure 7, Item 1), washers, and new locknuts. Tighten bolts securely.

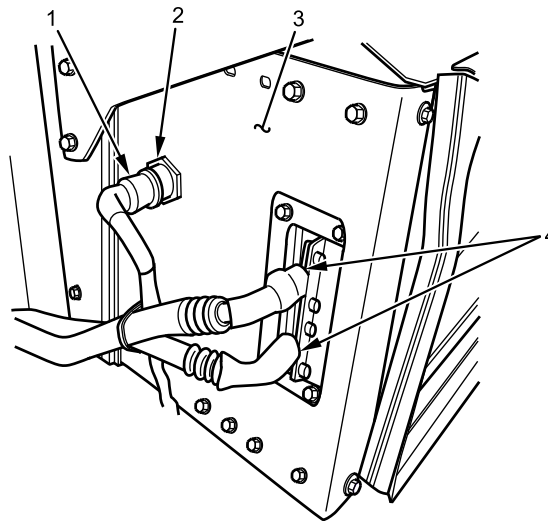

B235203379

Figure 8. HVAC Condenser Lines.

7. Remove cap and plug from ends of HVAC lines (Figure 8, Item 4).
8. Lubricate new O-rings with PAG oil and install on HVAC lines (Figure 8, Item 4).
9. Install HVAC lines (Figure 8, Item 4) on condenser unit (Figure 8, Item 3) and tighten securely.

NOTE

Fan harness connector has alignment pin that goes into condenser housing unit.

10. Install fan harness connector retaining nut (Figure 8, Item 2) on condenser housing unit (Figure 8, Item 3) and tighten securely.
11. Connect fan electrical connector (Figure 8, Item 1).

END OF TASK

HEATING VENTILATING AND AIR CONDITIONING (HVAC) CONDENSER REMOVAL AND INSTALLATION - (CONTINUED)**FOLLOW-ON MAINTENANCE**

1. Charge HVAC system (WP 0707).
2. Check for leaks (TM 9-2355-106-10).
3. Turn MAIN POWER switch on (TM 9-2355-106-10).
4. Start engine (TM 9-2355-106-10).
5. Verify HVAC system operation (TM 9-2355-106-10).
6. Turn engine off (TM 9-2355-106-10).
7. Turn MAIN POWER switch off (TM 9-2355-106-10).
8. Install A/C condenser panel (WP 0672).
9. Remove wheel chocks (TM 9-2355-106-10).

END OF TASK**END OF WORK PACKAGE**

FIELD MAINTENANCE
AIR CONDITIONER CONDENSER FAN ASSEMBLY REMOVAL AND INSTALLATION

INITIAL SETUP:**Tools and Special Tools**

General Mechanic's Tool Kit (GMTK)
(WP 0795, Item 37)

TM 9-2355-106-23P

WP 0786

WP 0782

Materials/Parts

Lockwasher - (9) (WP 0796, Item 168)
Grease (WP 0794, Item 22)
Gloves (WP 0794, Item 18)
Goggles, industrial (WP 0794, Item 20)
Faceshield, industrial (WP 0794, Item 16)

Equipment Condition

Parking brake set (TM 9-2355-106-10)
Transmission set in NEUTRAL (N) (TM 9-2355-106-10)
Engine off (TM 9-2355-106-10)
MAIN POWER switch off (TM 9-2355-106-10)
Wheels chocked (TM 9-2355-106-10)
Air Conditioning (A/C) condenser panel removed (WP 0672)

References

TM 9-2355-106-10

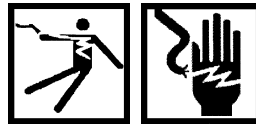
WARNING

Use extreme caution when testing or working on or around electrical circuits. Always assume that electrical circuits are live. Electrical shock can occur upon contact with voltage high enough to cause current flow through muscles or nerves. On Direct Current (DC) systems, generally 1 milliamp of current can be felt, 5 milliamps can cause severe pain, 15 milliamps can cause loss of muscle control, and 70 milliamps can be fatal. Wear protective clothing; ensure skin, clothing, and surrounding areas are dry; do not wear jewelry; and touch only the insulated, nonmetallic parts of electrical components and testing equipment. To prevent electrical arcing, avoid shorting electrical test probes and jumper wires. Electrical arcing can cause bright flashes of light, capable of causing temporary blindness. If electrical injury occurs, immediately shut off power supply and seek medical assistance. Failure to comply may result in serious injury or death to personnel.

Do not use parts other than those specified for the system being serviced. Failure to comply may result in damage to equipment and serious injury or death to personnel.

AIR CONDITIONER CONDENSER FAN ASSEMBLY REMOVAL AND INSTALLATION - (CONTINUED)**REMOVAL****NOTE**

Left side shown; right side similar.

1. Disconnect condenser control harness connector (Figure 1, Item 1) from condenser fan assembly harness connector (Figure 1, Item 3).

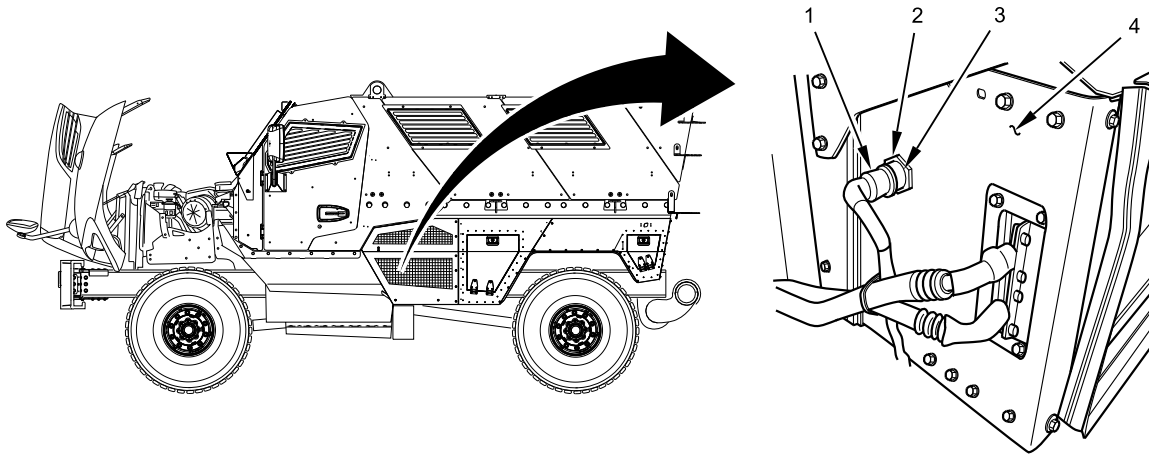
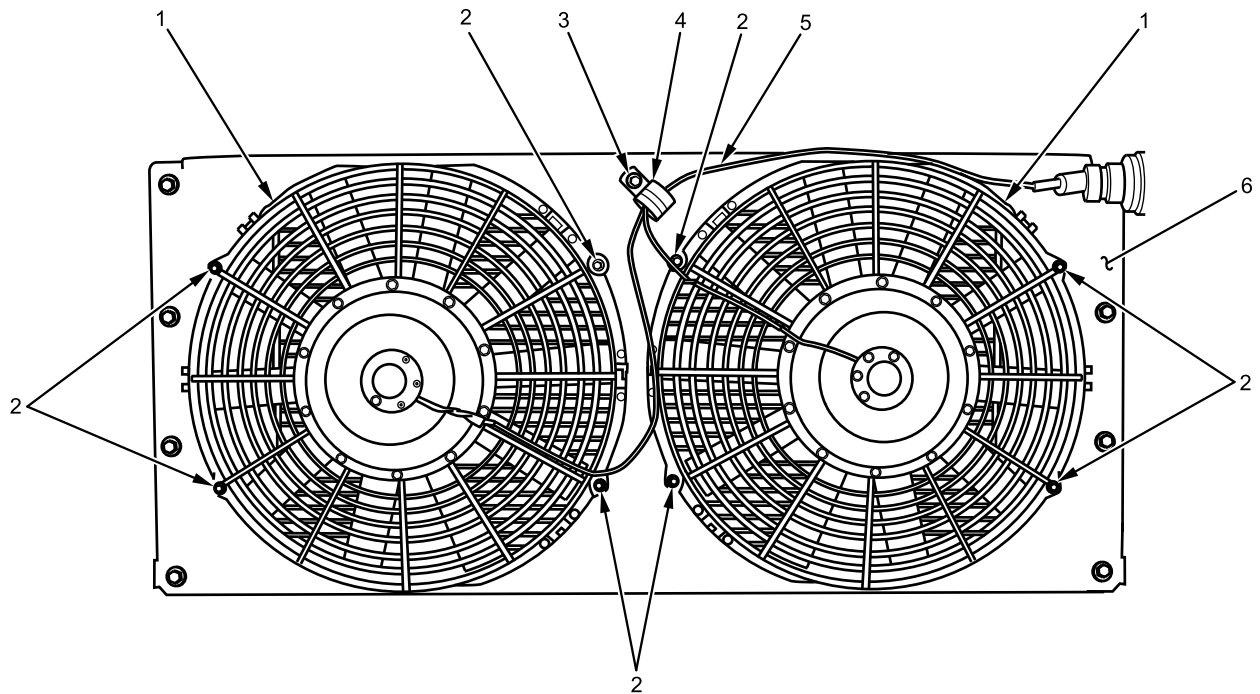

Figure 1. Condenser Fan Assembly Harness Connection.

2. Remove condenser fan assembly harness connector retaining nut (Figure 1, Item 2) from condenser fan assembly harness connector (Figure 1, Item 3).
3. Remove condenser fan assembly harness connector (Figure 1, Item 3) from condenser housing (Figure 1, Item 4)

AIR CONDITIONER CONDENSER FAN ASSEMBLY REMOVAL AND INSTALLATION - (CONTINUED)



B230003761

Figure 2. Condenser Fan Assembly.

NOTE

Condenser fan assembly is mounted to back side of condenser housing.

Left side shown; right side similar.

4. Remove retaining bolt, lockwasher, flat washer (Figure 2, Item 3), and harness clip (Figure 2, Item 4) from condenser fan assembly harness (Figure 2, Item 5).
5. Remove eight bolts, lockwashers, flat washers (Figure 2, Item 2), and condenser fan assembly (Figure 2, Item 1) from condenser housing (Figure 2, Item 6).
6. Discard lockwashers.

END OF TASK

AIR CONDITIONER CONDENSER FAN ASSEMBLY REMOVAL AND INSTALLATION - (CONTINUED)

INSTALLATION

WARNING



Dielectric grease is harmful to skin and eyes. If grease contacts eyes, rinse thoroughly and contact physician if irritation persists. If skin is contacted, wash thoroughly with soap and water. Failure to comply may result in serious injury to personnel.

Corrosion preventive compound is toxic. Use only in well-ventilated area. Do not get in eyes; wear chemical safety goggles and full-face shield when using. Avoid contact with skin and wear rubber or plastic, solvent-resistant gloves. In case of contact, remove contaminated clothing and immediately wash area with soap and water. If compound contacts eyes, flush eyes with large amounts of water for at least 15 minutes and get immediate medical attention. If swallowed, do not induce vomiting; contact a physician immediately. Failure to comply may result in serious injury or death to personnel.

NOTE

Apply dielectric grease to air conditioner condenser fan assembly harness connection.

Apply corrosion preventive compound to all bolt threads.

Left side shown; right side similar

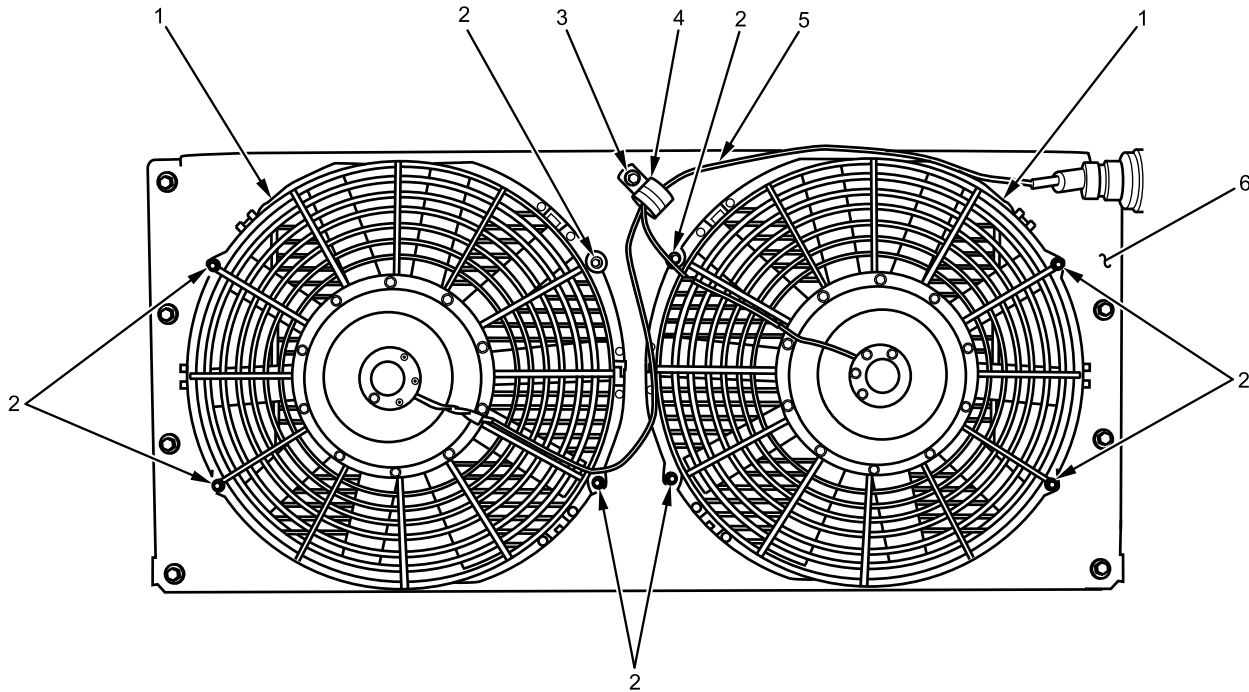

Figure 3. Condenser Fan Assembly.

B230003761

AIR CONDITIONER CONDENSER FAN ASSEMBLY REMOVAL AND INSTALLATION - (CONTINUED)

1. Install condenser fan assembly (Figure 3, Item 1) on condenser housing (Figure 3, Item 6) with eight flat washers, new lockwashers, and bolts (Figure 3, Item 2). Tighten bolts securely.
2. Install condenser fan assembly harness (Figure 3, Item 5) with harness clip (Figure 3, Item 4), flat washer, new lockwasher, and bolt (Figure 3, Item 3). Tighten bolt securely.

NOTE

Left side shown; right side similar

3. Position condenser fan assembly harness connector (Figure 4, Item 3) in condenser housing (Figure 4, Item 4).

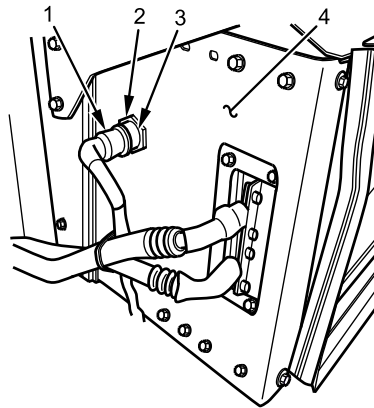

B232212043

Figure 4. Condenser Fan Assembly Harness Connection.

4. Install condenser fan assembly harness connector retaining nut (Figure 4, Item 2) on condenser fan assembly harness connector (Figure 4, Item 3) and tighten securely.
5. Connect condenser control harness connector (Figure 4, Item 1) to condenser fan assembly harness connector (Figure 4, Item 3).

END OF TASK**FOLLOW-ON MAINTENANCE**

1. Install air conditioning A/C condenser panel (WP 0672).
2. Remove wheel chocks (TM 9-2355-106-10).

END OF TASK**END OF WORK PACKAGE**

FIELD MAINTENANCE**ENGINE WATER OUTLET PIPE AND ELBOW REMOVAL AND INSTALLATION**

INITIAL SETUP:**Tools and Special Tools**

General Mechanic's Tool Kit (GMTK)
(WP 0795, Item 37)
Pan, drain, 5-gal. capacity (WP 0795, Item 75)

TM 9-2355-106-23P

WP 0786

WP 0782

Materials/Parts

Antifreeze (WP 0794, Item 5)
Gloves (WP 0794, Item 18)
Faceshield, industrial (WP 0794, Item 16)
Goggles, industrial (WP 0794, Item 20)
Rag (WP 0794, Item 39)
Dispenser, sealant (WP 0794, Item 14)
Sealing compound (WP 0794, Item 44)

Equipment Condition

Parking brake set (TM 9-2355-106-10)
Transmission set in NEUTRAL (N) (TM
9-2355-106-10)
Engine off (TM 9-2355-106-10)
MAIN POWER switch off (TM 9-2355-106-10)
Wheels chocked (TM 9-2355-106-10)
Engine hood open and secured (TM 9-2355-106-10)
Cooling system drained (WP 0277)
Alternator removed (WP 0289)
Alternator bracket removed (WP 0290)

References

TM 9-2355-106-10

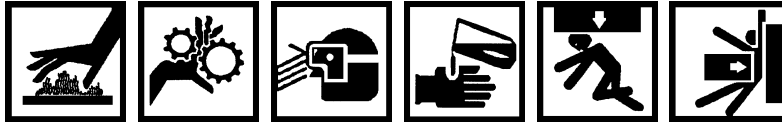
ENGINE WATER OUTLET PIPE AND ELBOW REMOVAL AND INSTALLATION - (CONTINUED)**WARNING**

Wear safety goggles and work gloves while servicing cooling system. Label all connections and reference areas before removing parts. Failure to comply may result in damage to equipment and serious injury or death to personnel.

Engine components become extremely hot during normal operation. Allow engine to cool completely prior to performing maintenance. Use extreme care when working in close quarters in engine compartment. Stay clear of rotating parts. Wear safety goggles, work gloves, and long sleeves or shop coat. Failure to comply may result in serious injury or death to personnel.

Cooling system components become pressurized and extremely hot during normal operation. To prevent serious injury from hot coolant or scalding steam, use the following safety procedure when removing radiator cap, surge tank cap, or deaeration cap:

- Allow engine to cool for 15 minutes.
- Wrap a thick cloth around cap to be removed.
- Loosen cap slowly one-quarter to one-half turn counterclockwise, and pause to allow pressure to release.
- Continue to turn cap counterclockwise to remove.
- Ensure all personnel stay clear of radiator while engine is running. Air in radiator will be released, which may cause hot coolant to spray out. Failure to comply may result in serious injury to personnel.

Engine hood is extremely heavy and requires two-person lift. Ensure that there is adequate space in front of the vehicle to open hood completely without pinning or pinching personnel between hood and any other structure. Use extreme care when working under hood and make sure it is properly supported. Failure to comply may result in serious injury or death to personnel.

ENGINE WATER OUTLET PIPE AND ELBOW REMOVAL AND INSTALLATION - (CONTINUED)**REMOVAL**

1. Position clean drain pan under engine water outlet pipe assembly (Figure 1, Item 10).

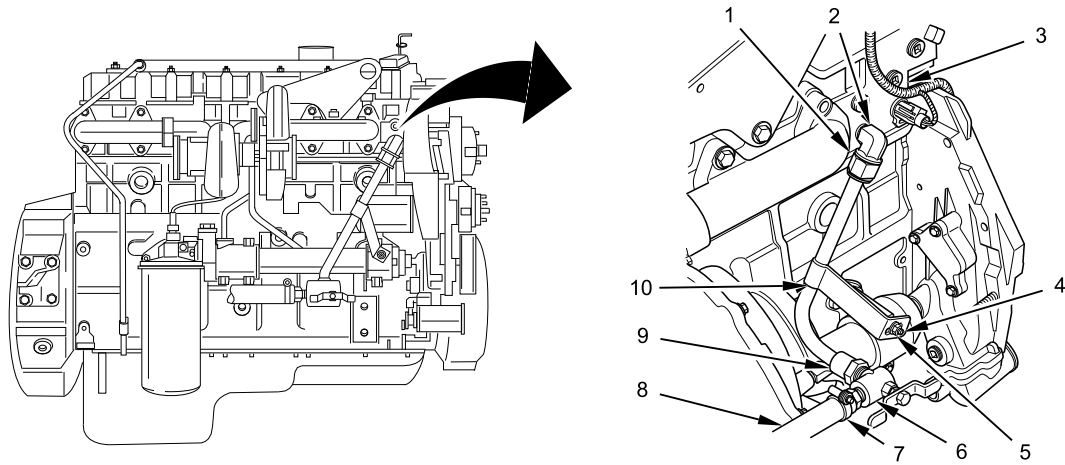

B235204202

Figure 1. Engine Water Outlet Pipe Assembly.

2. Loosen hose clamp (Figure 1, Item 7) and remove shutoff valve (Figure 1, Item 6) from rubber heater hose (Figure 1, Item 8).
3. Remove shutoff valve (Figure 1, Item 6) from fixed connector (Figure 1, Item 9). Clean threads of any loose sealing compound.
4. Remove connector (Figure 1, Item 1) from elbow (Figure 1, Item 2).
5. Remove nut (Figure 1, Item 5) from stud (Figure 1, Item 4).
6. Remove engine water outlet pipe assembly (Figure 1, Item 10).
7. Mark orientation of elbow (Figure 1, Item 2) on cylinder head (Figure 1, Item 3).
8. Remove elbow (Figure 1, Item 2) from cylinder head (Figure 1, Item 3). Clean threads of any loose sealing compound.

END OF TASK

ENGINE WATER OUTLET PIPE AND ELBOW REMOVAL AND INSTALLATION - (CONTINUED)

INSTALLATION

WARNING



Sealing compound is toxic. Use only in well-ventilated area. Do not get in eyes; wear chemical safety goggles and full faceshield when using. Avoid contact with skin and wear rubber or plastic, solvent-resistant gloves. In case of contact, remove contaminated clothing and immediately wash area with soap and water. If compound contacts eyes, flush eyes with large amounts of water for at least 15 minutes and get immediate medical attention. If swallowed, do not induce vomiting; contact a physician immediately. Failure to comply may result in serious injury or death to personnel.

1. Apply sealing compound to threads of elbow (Figure 2, Item 2) and install elbow into cylinder head (Figure 2, Item 1) by hand until snug.

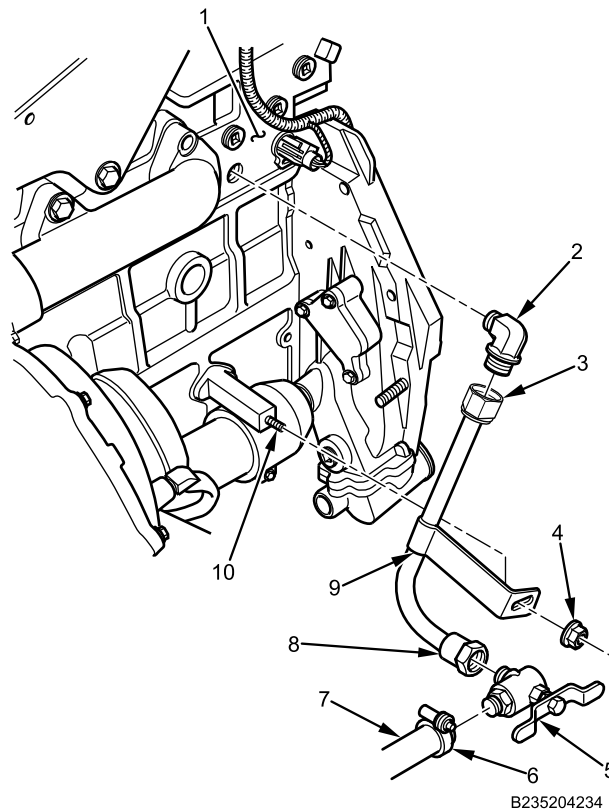

Figure 2. Engine Water Outlet Pipe Assembly.

ENGINE WATER OUTLET PIPE AND ELBOW REMOVAL AND INSTALLATION - (CONTINUED)

2. Tighten elbow (Figure 2, Item 2) until approximately 1/8 turn short of orientation mark on cylinder head (Figure 2, Item 1).
3. Place connector (Figure 2, Item 3) on elbow (Figure 2, Item 2) and hand tighten.
4. Tighten elbow (Figure 2, Item 2) until engine water outlet pipe assembly (Figure 2, Item 9) aligns with stud (Figure 2, Item 10).
5. Install and tighten nut (Figure 2, Item 4) securely.
6. Tighten connector (Figure 2, Item 3) securely.
7. Apply sealing compound to threads of shutoff valve (Figure 2, Item 5) and install into connector (Figure 2, Item 8). Tighten valve until other end of valve aligns with rubber heater hose (Figure 2, Item 7).
8. Install shutoff valve (Figure 2, Item 5) into rubber heater hose (Figure 2, Item 7) and tighten hose clamp (Figure 2, Item 6) securely.
9. Remove drain pan and recycle contents back into cooling system prior to topping off.

END OF TASK**FOLLOW-ON MAINTENANCE**

1. Install alternator bracket (WP 0290).
2. Install alternator (WP 0289).
3. Fill cooling system (WP 0277).
4. Close engine hood (TM 9-2355-106-10).
5. Remove wheel chocks (TM 9-2355-106-10).

END OF TASK**END OF WORK PACKAGE**

FIELD MAINTENANCE
**HEATING VENTILATING AND AIR CONDITIONING (HVAC) 3-WAY VALVE COOLANT OUTLET HOSE
REMOVAL AND INSTALLATION**

INITIAL SETUP:**Tools and Special Tools**

General Mechanic's Tool Kit (GMTK)
(WP 0795, Item 37)
Pan, drain, 5-gal. capacity (WP 0795, Item 75)

WP 0786

WP 0782

Equipment Condition

Parking brake set (TM 9-2355-106-10)
Transmission set in NEUTRAL (N) (TM
9-2355-106-10)
Engine off (TM 9-2355-106-10)
MAIN POWER switch off (TM 9-2355-106-10)
Wheels chocked (TM 9-2355-106-10)
Engine hood open and secured (TM 9-2355-106-10)
Engine coolant drained (WP 0277)
Belly armor removed (WP 0606)
Right air conditioning (A/C) condenser panel
removed (WP 0672)

Materials/Parts

Goggles, industrial (WP 0794, Item 20)
Gloves (WP 0794, Item 19)
Wire (WP 0794, Item 57)
Cable lock strap - (6) (WP 0796, Item 134)
Clamp - (2) (WP 0796, Item 140)

References

TM 9-2355-106-10
TM 9-2355-106-23P

WARNING

Cooling system components become pressurized and extremely hot during normal operation. To prevent serious injury from hot coolant or scalding steam, use the following safety procedure when removing radiator cap, surge tank cap, or deaeration cap:

- Allow engine to cool for 15 minutes.
- Wrap a thick cloth around cap to be removed.
- Loosen cap slowly one-quarter to one-half turn counterclockwise, and pause to allow pressure to release.
- Continue to turn cap counterclockwise to remove.
- Ensure all personnel stay clear of radiator while engine is running. Air in radiator will be released, which may cause hot coolant to spray out. Failure to comply may result in serious injury to personnel.

Wear safety goggles and work gloves while servicing cooling system. Label all connections and reference areas before removing parts. Failure to comply may result in damage to equipment and serious injury or death to personnel.

HEATING VENTILATING AND AIR CONDITIONING (HVAC) 3-WAY VALVE COOLANT OUTLET HOSE REMOVAL AND INSTALLATION - (CONTINUED)

NOTE

Remove cable lock straps as necessary to perform procedure. Note position and size of cable lock straps to aid installation.

REMOVAL

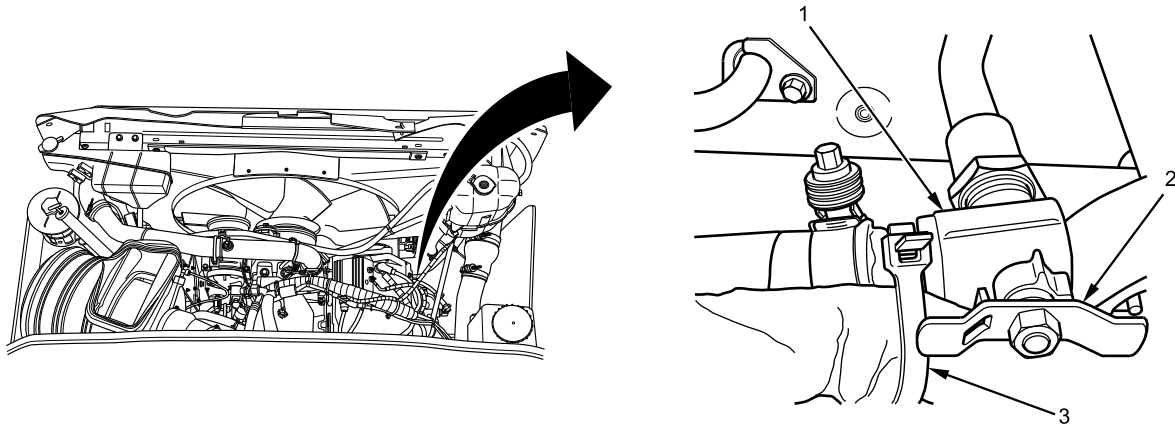

B235203109

Figure 1. Heater Coolant Engine Outlet Valve.

1. Close outlet valve (Figure 1, Item 1) by turning handle (Figure 1, Item 2) clockwise. Remove and discard cable lock strap (Figure 1, Item 3) if necessary.

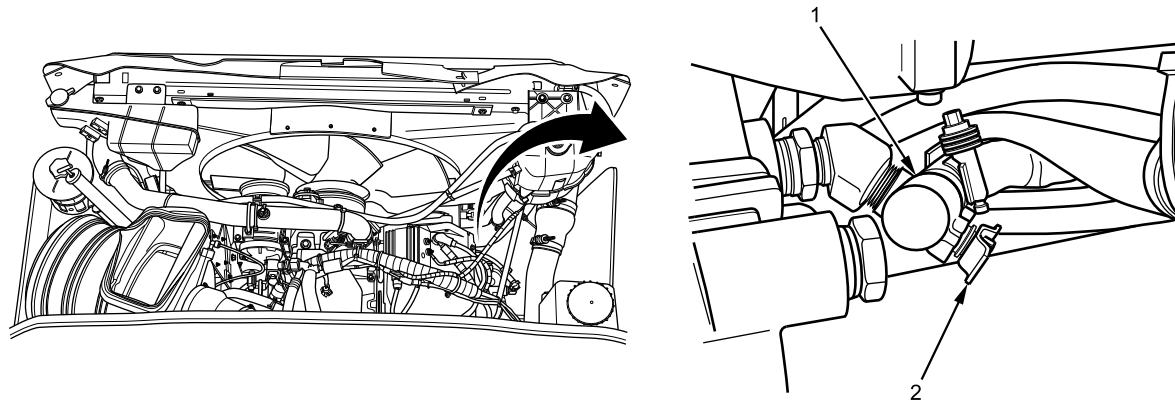

B235203108

Figure 2. Heater Coolant Engine Inlet Valve.

2. Close inlet valve (Figure 2, Item 1) by turning handle (Figure 2, Item 2) clockwise.

HEATING VENTILATING AND AIR CONDITIONING (HVAC) 3-WAY VALVE COOLANT OUTLET HOSE REMOVAL AND INSTALLATION - (CONTINUED)

Figure 3. Outlet Hose at 3-Way Valve.

3. Loosen clamp (Figure 3, Item 2) and disconnect hose (Figure 3, Item 3) and heat shielding (Figure 3, Item 4) from 3-way valve (Figure 3, Item 1). Remove clamp from hose. Discard clamp.

NOTE

Placing cap on hose will prevent coolant from draining out of hose until hose is lowered to drain pan.

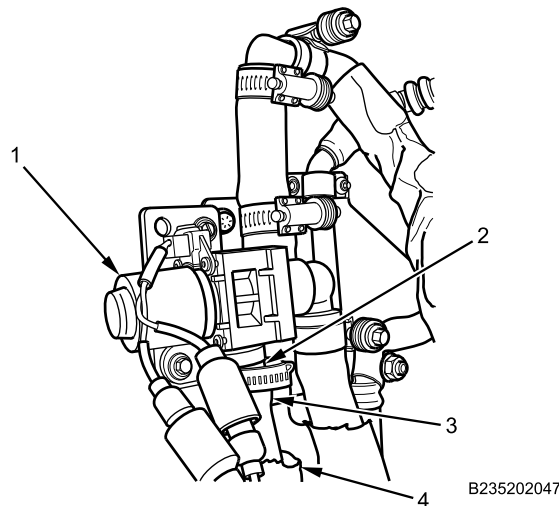
4. Place cap on end of end of hose (Figure 3, Item 3).
5. Securely connect mechanic's wire to end of hose (Figure 3, Item 3).

HEATING VENTILATING AND AIR CONDITIONING (HVAC) 3-WAY VALVE COOLANT OUTLET HOSE REMOVAL AND INSTALLATION - (CONTINUED)

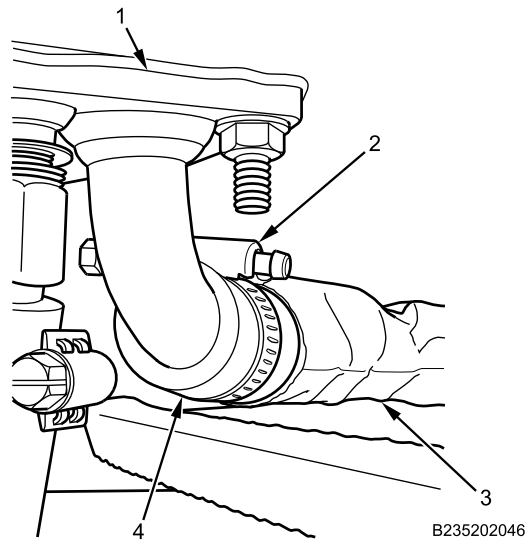

Figure 4. Outlet Hose at Dust Plate.

NOTE

Dust plate is located under cabin floor, below right front seat.

6. Pull hose (Figure 4, Item 4), heat shielding (Figure 4, Item 3), and mechanic's wire towards dust plate (Figure 4, Item 1), guiding hose next to transmission for draining into pan.
7. Position drain pan under hose (Figure 4, Item 4), remove cap from hose, and allow all coolant to drain into pan.
8. Loosen clamp (Figure 4, Item 2) and disconnect hose (Figure 4, Item 4) and heat shielding (Figure 4, Item 3) from dust plate (Figure 4, Item 1). Remove clamp from hose. Discard clamp.
9. Remove hose (Figure 4, Item 4) and heat shielding (Figure 4, Item 3) from vehicle. Disconnect mechanic's wire. Remove heat shielding (Figure 4, Item 3) from hose (Figure 4, Item 4).

END OF TASK

INSTALLATION

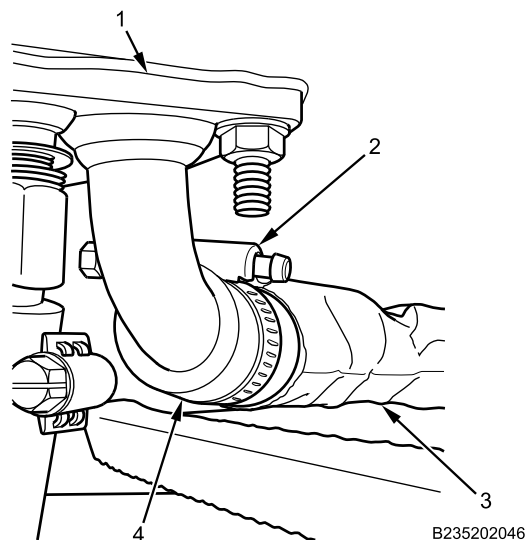

Figure 5. Outlet Hose at Dust Plate.

HEATING VENTILATING AND AIR CONDITIONING (HVAC) 3-WAY VALVE COOLANT OUTLET HOSE REMOVAL AND INSTALLATION - (CONTINUED)

1. Install heat shielding (Figure 5, Item 3) on hose (Figure 5, Item 4).
2. Securely connect mechanic's wire to end of hose (Figure 5, Item 4) at dust plate location.

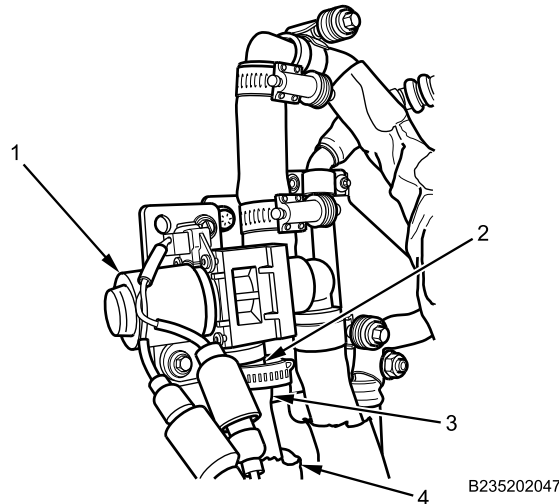

Figure 6. Outlet Hose at 3-Way Valve.

3. From 3-way valve (Figure 6, Item 1), pull mechanic's wire, hose (Figure 6, Item 3), and heat shielding (Figure 6, Item 4) to 3-way valve (Figure 6, Item 1). Disconnect mechanic's wire.
4. Position new clamp (Figure 6, Item 2) on hose (Figure 6, Item 3).
5. Connect hose (Figure 6, Item 3) and heat shielding (Figure 6, Item 4) to 3-way valve (Figure 6, Item 1) with clamp (Figure 6, Item 2) and tighten securely.
6. Position new clamp (Figure 5, Item 2) on hose (Figure 5, Item 4).
7. Connect hose (Figure 5, Item 4) and heat shielding (Figure 5, Item 3) to dust plate (Figure 5, Item 1) with clamp (Figure 5, Item 2) and tighten securely.

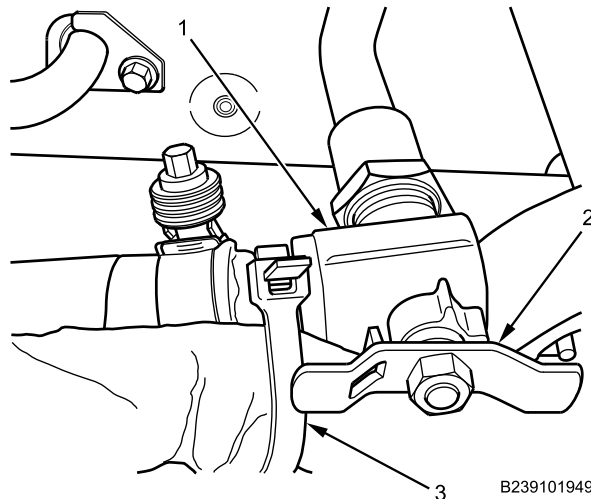

Figure 7. Heater Coolant Engine Outlet Valve.

8. Open valve (Figure 7, Item 1) by turning handle (Figure 7, Item 2) counterclockwise. Install new cable lock strap (Figure 7, Item 3) if removed.

HEATING VENTILATING AND AIR CONDITIONING (HVAC) 3-WAY VALVE COOLANT OUTLET HOSE REMOVAL AND INSTALLATION - (CONTINUED)

9. Install all cable lock straps and tighten securely.

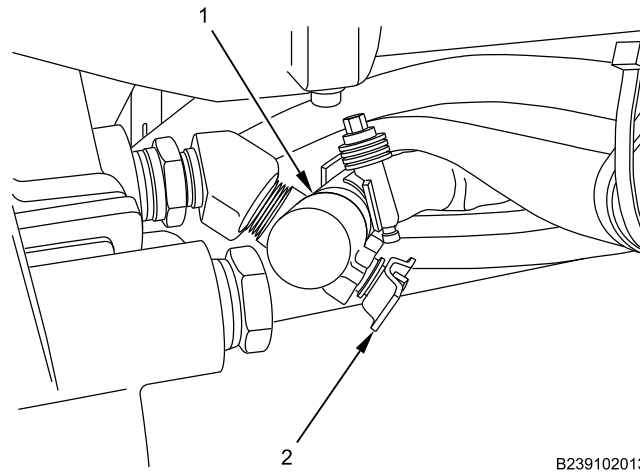

Figure 8. Heater Coolant Engine Inlet Valve.

10. Open valve (Figure 8, Item 1) by turning handle (Figure 8, Item 2) counterclockwise.
11. Remove drain pan.

END OF TASK**FOLLOW-ON MAINTENANCE**

1. Fill cooling system (WP 0277).
2. Turn MAIN POWER switch on (TM 9-2355-106-10).
3. Turn engine on (TM 9-2355-106-10).
4. Start vehicle, run up to operating temperature, check for coolant leaks (TM 9-2355-106-10).
5. Turn engine off (TM 9-2355-106-10).
6. Turn MAIN POWER switch off (TM 9-2355-106-10).
7. Install right A/C condenser panel (WP 0672).
8. Install belly armor (WP 0606).
9. Close and secure engine hood (TM 9-2355-106-10).
10. Remove wheel chocks (TM 9-2355-106-10).

END OF TASK**END OF WORK PACKAGE**

FIELD MAINTENANCE
HEATING VENTILATING AND AIR CONDITIONING (HVAC) 3-WAY VALVE REMOVAL AND INSTALLATION

INITIAL SETUP:**Tools and Special Tools**

General Mechanic's Tool Kit (GMTK)
(WP 0795, Item 37)
Pan, drain, 5-gal. capacity (WP 0795, Item 75)

WP 0786

WP 0782

Materials/Parts

Antifreeze (WP 0794, Item 5)
Cable lock strap (WP 0796, Item 145)
Clamp - (5) (WP 0796, Item 140)

Equipment Condition

Parking brake set (TM 9-2355-106-10)
Transmission set in NEUTRAL (N) (TM 9-2355-106-10)
Engine off (TM 9-2355-106-10)
MAIN POWER switch off (TM 9-2355-106-10)
Wheels chocked (TM 9-2355-106-10)
Engine hood open and secured (TM 9-2355-106-10)
Engine coolant drained (WP 0277)

References

TM 9-2355-106-10
TM 9-2355-106-23P

WARNING

Engine hood is extremely heavy and requires two-person lift. Ensure that there is adequate space in front of the vehicle to open hood completely without pinning or pinching personnel between hood and any other structure. Use extreme care when working under hood and make sure it is properly supported. Failure to comply may result in serious injury or death to personnel.

Cooling system components become pressurized and extremely hot during normal operation. To prevent serious injury from hot coolant or scalding steam, use the following safety procedure when removing radiator cap, surge tank cap, or deaeration cap:

- Allow engine to cool for 15 minutes.
- Wrap a thick cloth around cap to be removed.
- Loosen cap slowly one-quarter to one-half turn counterclockwise, and pause to allow pressure to release.
- Continue to turn cap counterclockwise to remove.
- Ensure all personnel stay clear of radiator while engine is running. Air in radiator will be released, which may cause hot coolant to spray out. Failure to comply may result in serious injury to personnel.

Wear safety goggles and work gloves while servicing cooling system. Label all connections and reference areas before removing parts. Failure to comply may result in damage to equipment and serious injury or death to personnel.

HEATING VENTILATING AND AIR CONDITIONING (HVAC) 3-WAY VALVE REMOVAL AND INSTALLATION - (CONTINUED)**NOTE**

Remove cable lock straps as necessary to perform procedure. Note position and size of cable lock straps to aid in installation.

REMOVAL

1. Close outlet valve (Figure 1, Item 1) by turning handle (Figure 1, Item 2) clockwise. Remove and discard cable lock strap (Figure 1, Item 3) if necessary.

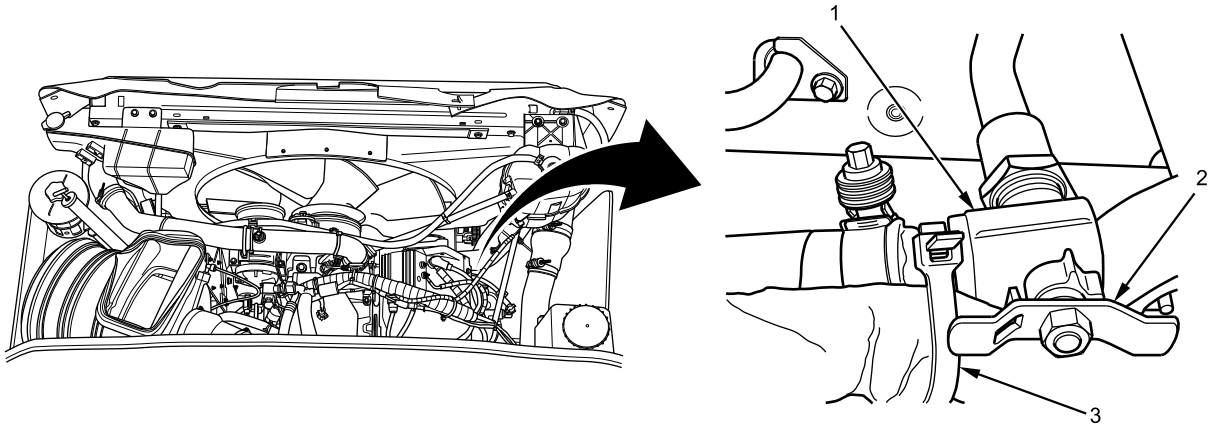

B235203109

Figure 1. Heater Coolant Engine Outlet Valve.

2. Close inlet valve (Figure 2, Item 1) by turning handle (Figure 2, Item 2) clockwise.

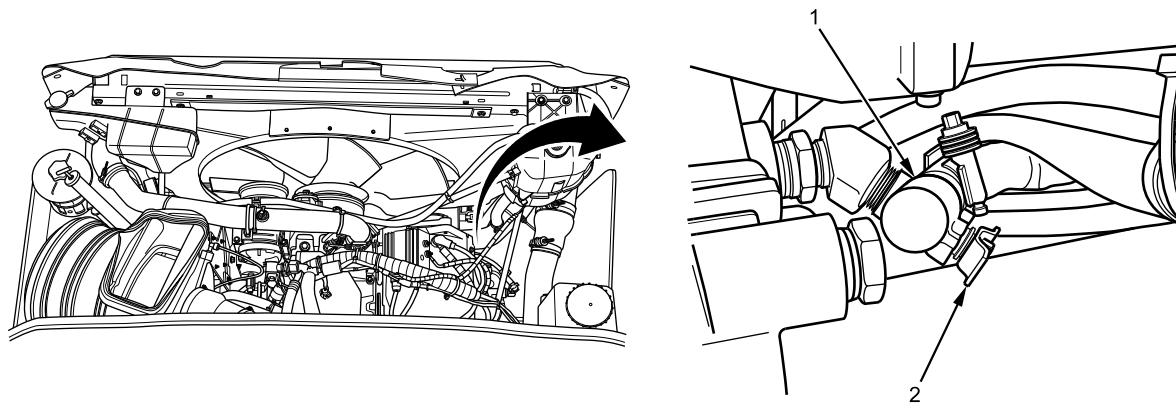

B235203108

Figure 2. Heater Coolant Engine Inlet Valve.

HEATING VENTILATING AND AIR CONDITIONING (HVAC) 3-WAY VALVE REMOVAL AND INSTALLATION - (CONTINUED)

3. Disconnect 3-way valve electrical connectors (Figure 3, Item 7) from engine wiring harness (Figure 3, Item 6).

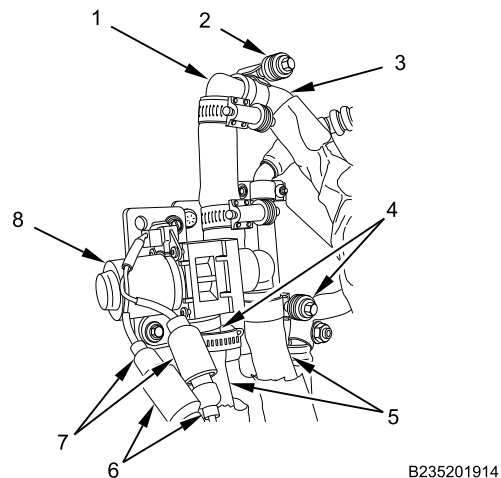

Figure 3. HVAC 3-Way Valve.

4. Position drain pan under 3-way valve (Figure 3, Item 8).

NOTE

Note location and orientation of hoses at 3-way valve to aid installation.

5. Loosen clamp (Figure 3, Item 2) and remove hose (Figure 3, Item 3) from elbow (Figure 3, Item 1). Allow coolant to drain into drain pan. Remove clamp from hose. Discard clamp.
6. Loosen clamps (Figure 3, Item 4) and remove hoses (Figure 3, Item 5) from 3-way valve (Figure 3, Item 8). Allow coolant to drain into drain pan. Remove clamps from hoses. Discard clamps.
7. Remove two bolts (Figure 4, Item 2) and remove 3-way valve (Figure 4, Item 3) and bracket from plate (Figure 4, Item 1).

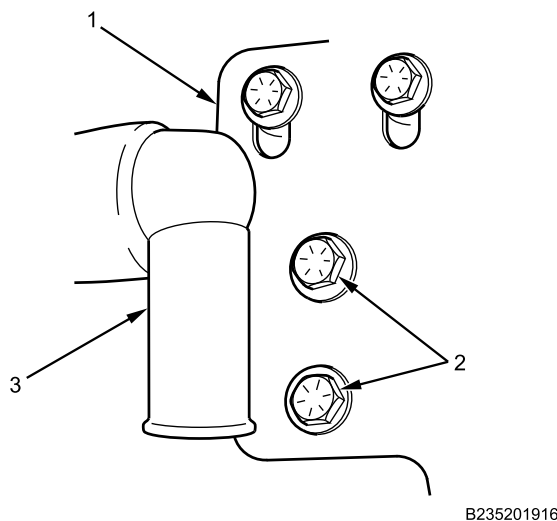

Figure 4. 3-Way Valve Bracket Bolts.

HEATING VENTILATING AND AIR CONDITIONING (HVAC) 3-WAY VALVE REMOVAL AND INSTALLATION - (CONTINUED)

- Loosen clamps (Figure 5, Item 4) and separate hose (Figure 5, Item 2) from elbow (Figure 5, Item 3) and 3-way valve (Figure 5, Item 5). Remove clamps from hose. Discard clamps.

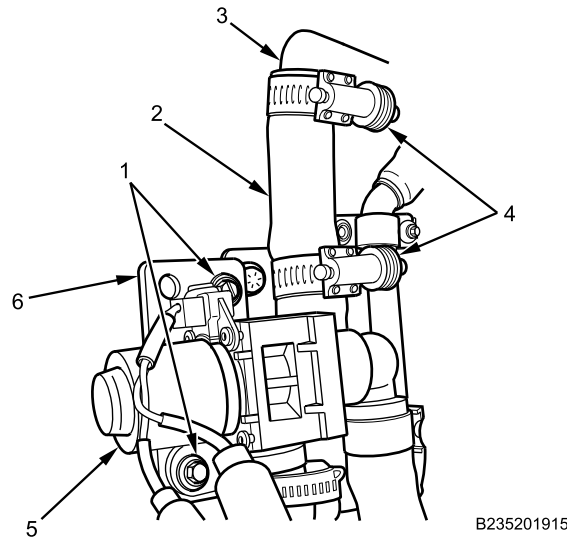

Figure 5. 3-Way Valve and Hose.

- Remove two bolts and washers (Figure 5, Item 1) and separate bracket (Figure 5, Item 6) from 3-way valve (Figure 5, Item 5).

END OF TASK

INSTALLATION

- Install bracket (Figure 6, Item 6) on 3-way valve (Figure 6, Item 5) with two bolts and washers (Figure 6, Item 1) and tighten securely.

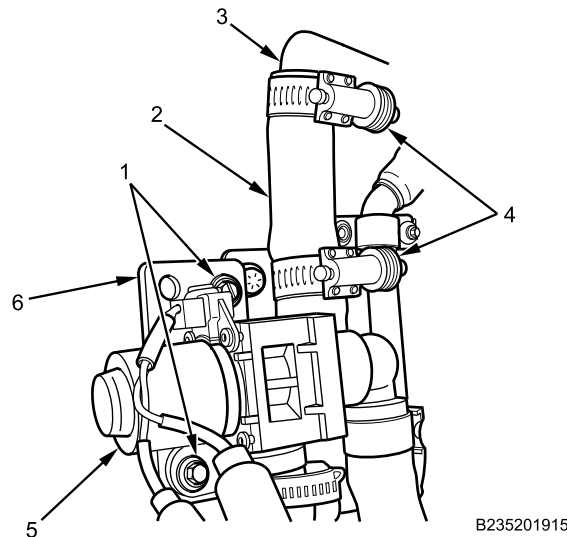

Figure 6. 3-Way Valve and Hose.

- Position new clamps (Figure 6, Item 4) on hose (Figure 6, Item 2) and connect hose to elbow (Figure 6, Item 3) and 3-way valve (Figure 6, Item 5). Tighten clamps securely.

HEATING VENTILATING AND AIR CONDITIONING (HVAC) 3-WAY VALVE REMOVAL AND INSTALLATION - (CONTINUED)

3. Position 3-way valve bracket behind plate (Figure 7, Item 1) and install 3-way valve (Figure 7, Item 3) and bracket with two bolts (Figure 7, Item 2). Tighten securely.

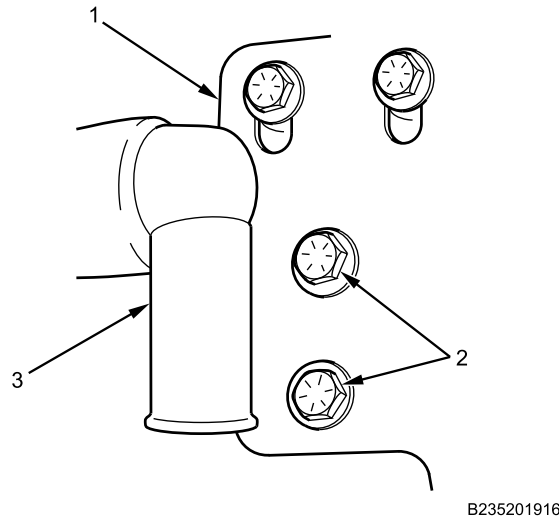

Figure 7. 3-Way Valve Bracket Bolts.

4. Position new clamps (Figure 8, Item 4) on hoses (Figure 8, Item 5) and connect hoses to 3-way valve (Figure 8, Item 8). Tighten clamps securely.

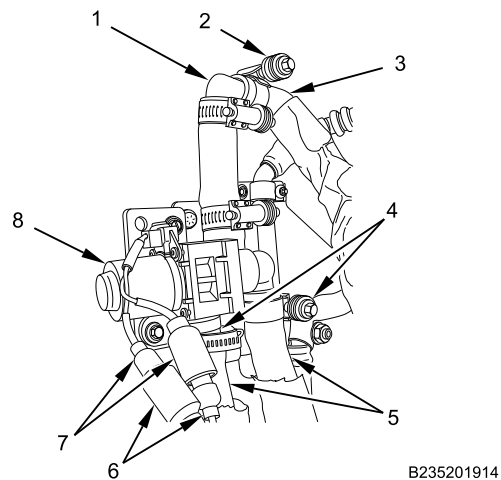

Figure 8. HVAC 3-Way Valve.

5. Position new clamp (Figure 8, Item 2) on hose (Figure 8, Item 3) and connect hose to elbow (Figure 8, Item 1). Tighten clamp securely.
6. Connect electrical connectors (Figure 8, Item 7) to engine harness (Figure 8, Item 6).

HEATING VENTILATING AND AIR CONDITIONING (HVAC) 3-WAY VALVE REMOVAL AND INSTALLATION - (CONTINUED)

7. Open outlet valve (Figure 9, Item 1) by turning handle (Figure 9, Item 2) counterclockwise. Install new cable lock strap (Figure 9, Item 3) if removed.

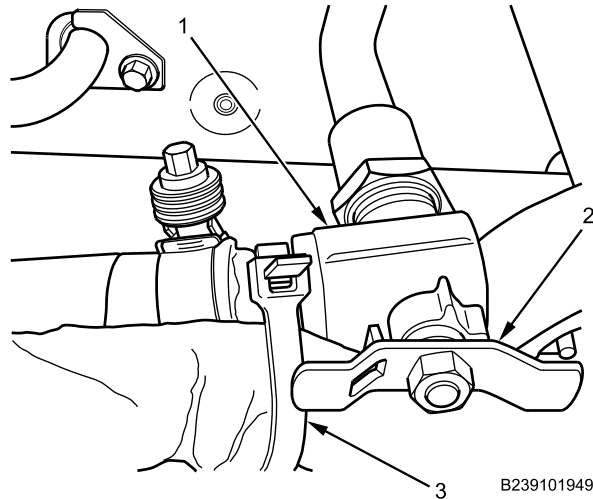

Figure 9. Heater Coolant Engine Outlet Valve.

8. Install all cable lock straps and tighten securely.
9. Remove drain pan.
10. Open inlet valve (Figure 10, Item 1) by turning handle (Figure 10, Item 2) counterclockwise.

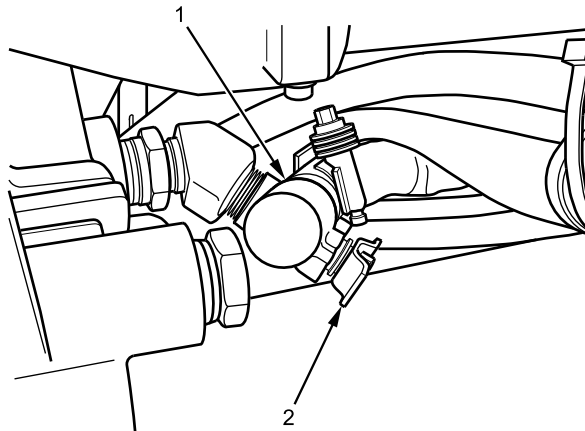

Figure 10. Heater Coolant Engine Inlet Valve.

END OF TASK

HEATING VENTILATING AND AIR CONDITIONING (HVAC) 3-WAY VALVE REMOVAL AND INSTALLATION - (CONTINUED)**FOLLOW-ON MAINTENANCE**

1. Fill cooling system (WP 0277).
2. Turn MAIN POWER switch on (TM 9-2355-106-10).
3. Turn engine on (TM 9-2355-106-10).
4. Verify correct HVAC system operation (TM 9-2355-106-10).
5. Turn engine off (TM 9-2355-106-10).
6. Turn MAIN POWER switch off (TM 9-2355-106-10).
7. Close and secure engine hood (TM 9-2355-106-10).
8. Remove wheel chocks (TM 9-2355-106-10).

END OF TASK**END OF WORK PACKAGE**

FIELD MAINTENANCE

HEATING VENTILATING AND AIR CONDITIONING (HVAC) CABIN HEATER HOSE REMOVAL AND INSTALLATION

INITIAL SETUP:

Tools and Special Tools

General Mechanic's Tool Kit (GMTK)
(WP 0795, Item 37)
Pan, drain, 5-gal. capacity (WP 0795, Item 75)

WP 0786

WP 0782

Equipment Condition

Parking brake set (TM 9-2355-106-10)
Transmission set in NEUTRAL (N) (TM 9-2355-106-10)
Engine off (TM 9-2355-106-10)
MAIN POWER switch off (TM 9-2355-106-10)
Wheels chocked (TM 9-2355-106-10)
Engine hood open and secured (TM 9-2355-106-10)
Cooling system drained (WP 0277)

Materials/Parts

Cable lock strap - (1) (WP 0796, Item 134)
Clamp, screw - (4) (WP 0796, Item 140)

References

TM 9-2355-106-10
TM 9-2355-106-23P

WARNING



Engine hood is extremely heavy and requires two-person lift. Ensure that there is adequate space in front of the vehicle to open hood completely without pinning or pinching personnel between hood and any other structure. Use extreme care when working under hood and make sure it is properly supported. Failure to comply may result in serious injury or death to personnel.

Cooling system components become pressurized and extremely hot during normal operation. To prevent serious injury from hot coolant or scalding steam, use the following safety procedure when removing radiator cap, surge tank cap, or deaeration cap:

- Allow engine to cool for 15 minutes.
- Wrap a thick cloth around cap to be removed.
- Loosen cap slowly one-quarter to one-half turn counterclockwise, and pause to allow pressure to release.
- Continue to turn cap counterclockwise to remove.
- Ensure all personnel stay clear of radiator while engine is running. Air in radiator will be released, which may cause hot coolant to spray out. Failure to comply may result in serious injury to personnel.

Wear safety goggles and work gloves while servicing cooling system. Label all connections and reference areas before removing parts. Failure to comply may result in damage to equipment and serious injury or death to personnel.

HEATING VENTILATING AND AIR CONDITIONING (HVAC) CABIN HEATER HOSE REMOVAL AND INSTALLATION - (CONTINUED)**NOTE**

This procedure applies to either of two heater hoses. Note hose routing prior to removal for proper installation.

Remove cable lock straps as necessary to perform procedure. Note position and size of cable lock straps to aid installation.

Heater coolant engine outlet valve is located on front right side of engine below alternator. Note hose routing prior to removal to facilitate installation.

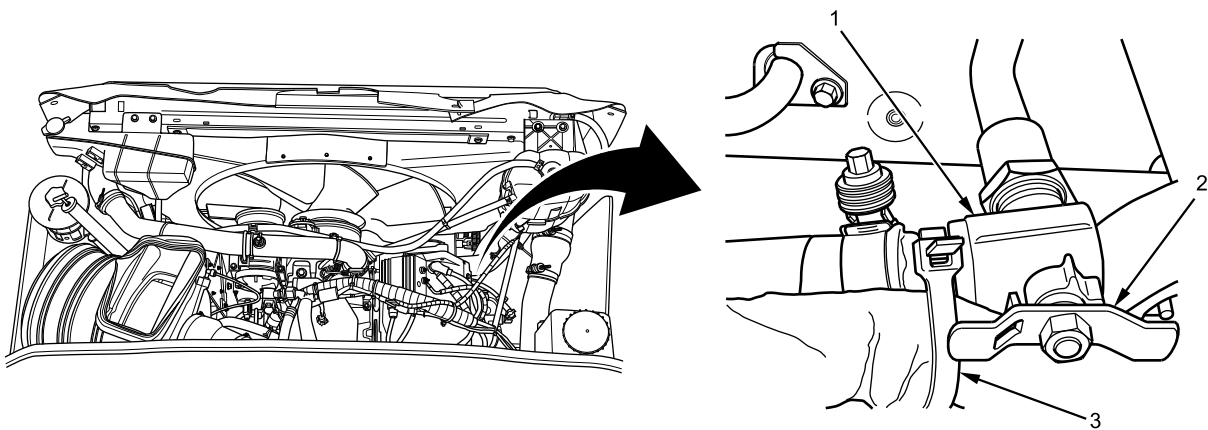
REMOVAL

B235203109

Figure 1. Heater Coolant Engine Outlet Valve.

1. Close valve (Figure 1, Item 1) by turning handle (Figure 1, Item 2) clockwise. Remove and discard cable lock strap (Figure 1, Item 3).

HEATING VENTILATING AND AIR CONDITIONING (HVAC) CABIN HEATER HOSE REMOVAL AND INSTALLATION - (CONTINUED)

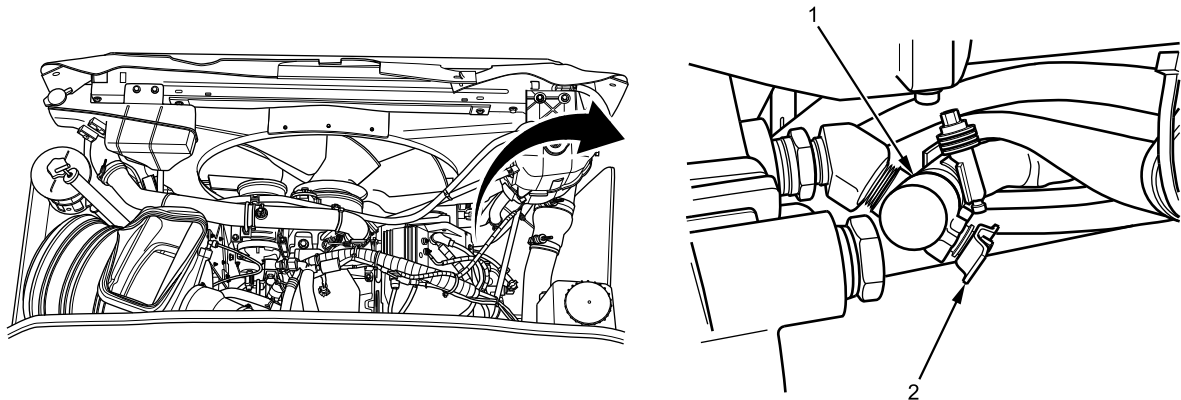

B235203108

Figure 2. Heater Coolant Engine Inlet Valve.

NOTE

Heater coolant engine inlet valve is located on front right side of engine below alternator.

2. Close valve (Figure 2, Item 1) by turning handle (Figure 2, Item 2) clockwise.

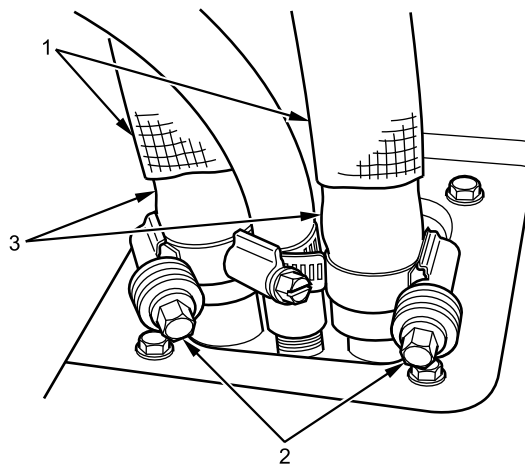

B235201926

Figure 3. Heater Hose Connections at Floor.

3. Position drain pan near heater hose connections at floor.
4. Loosen clamps (Figure 3, Item 2), disconnect heater hoses (Figure 3, Item 3) from cabin floor, and allow coolant to drain into drain pan. Remove clamps from heater hoses. Discard clamps.
5. Remove cable lock strap securing heat shield (Figure 3, Item 1) to heater hoses (Figure 3, Item 3). Discard cable lock strap.

HEATING VENTILATING AND AIR CONDITIONING (HVAC) CABIN HEATER HOSE REMOVAL AND INSTALLATION - (CONTINUED)

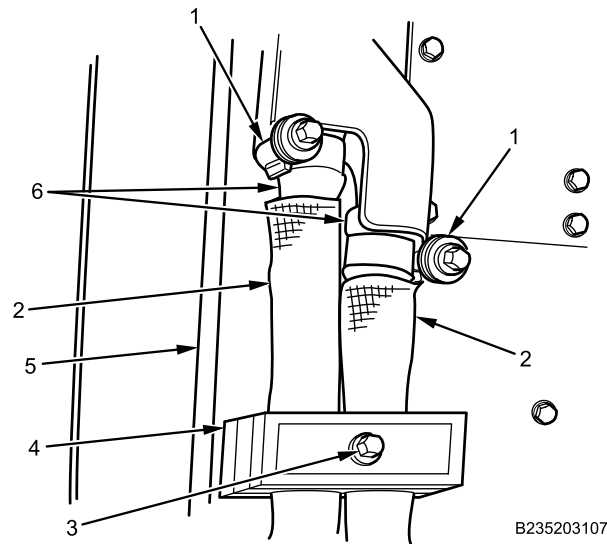

Figure 4. Heater Hose Connections at Life Support System (LSS) Box.

6. Remove bolt (Figure 4, Item 3) and washer from support block (Figure 4, Item 4).
7. Loosen clamps (Figure 4, Item 1) and disconnect heater hoses (Figure 4, Item 6) from LSS box (Figure 4, Item 5). Remove clamps from heater hoses. Discard clamps.
8. Remove heat shields (Figure 4, Item 2) from heater hoses (Figure 4, Item 6).

END OF TASK

INSTALLATION

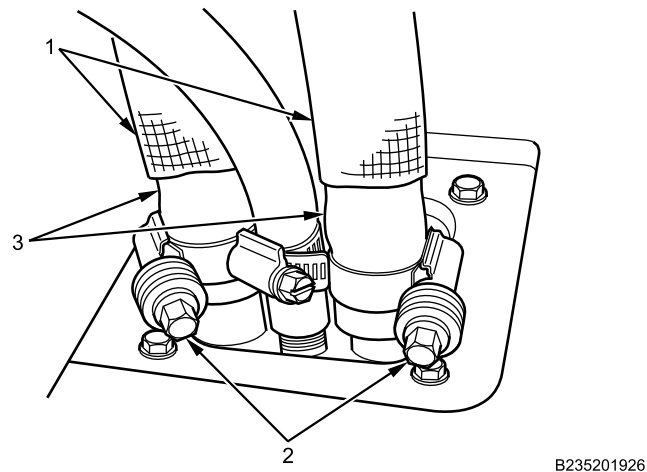

Figure 5. Heater Hose Connections at Floor.

1. Install heat shield (Figure 5, Item 1) on heater hoses (Figure 5, Item 3).
2. Position new clamps (Figure 5, Item 2) on end of heater hoses (Figure 5, Item 3) and connect heater hoses to cabin floor. Tighten clamps securely.

HEATING VENTILATING AND AIR CONDITIONING (HVAC) CABIN HEATER HOSE REMOVAL AND INSTALLATION - (CONTINUED)

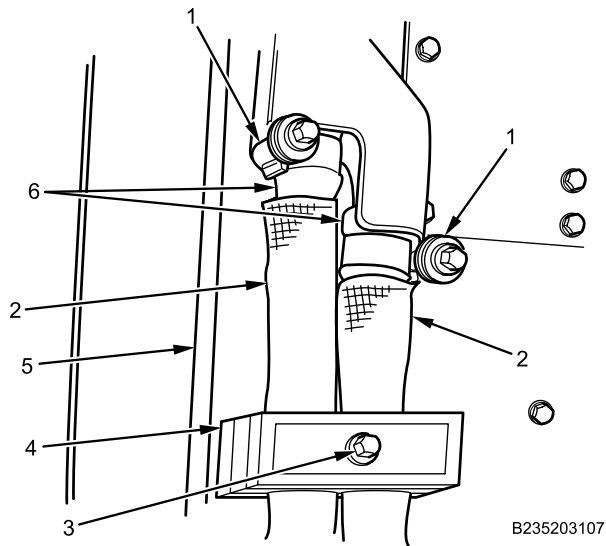

Figure 6. Heater Hose Connections at LSS Box.

3. Position new clamps (Figure 6, Item 1) on end of heater hoses (Figure 6, Item 6) and connect heater hose to LSS box (Figure 6, Item 5). Tighten clamp securely.
4. Install support block (Figure 6, Item 4) over heater hoses (Figure 6, Item 6) and heat shields (Figure 6, Item 2) with bolt (Figure 6, Item 3) and washer. Tighten bolt securely.

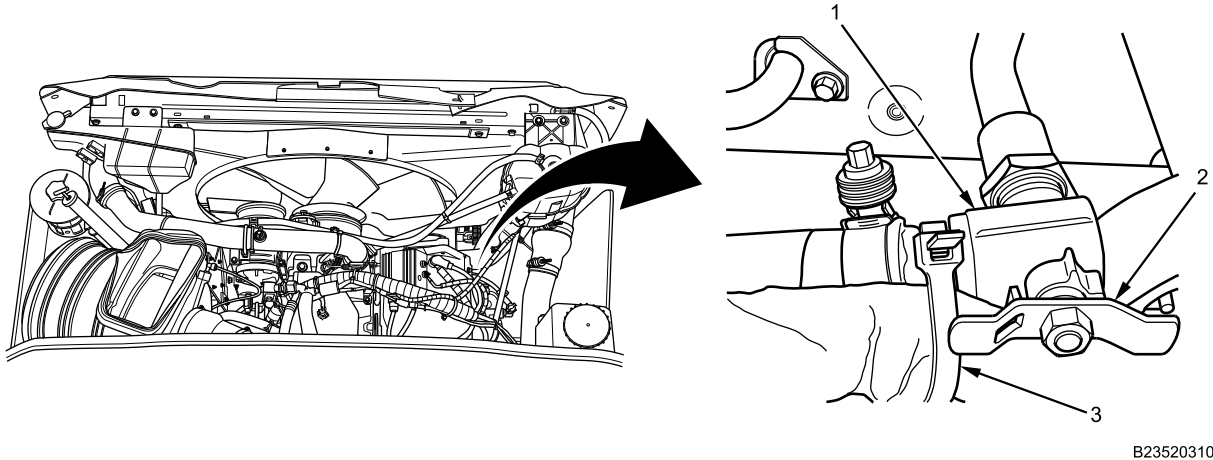
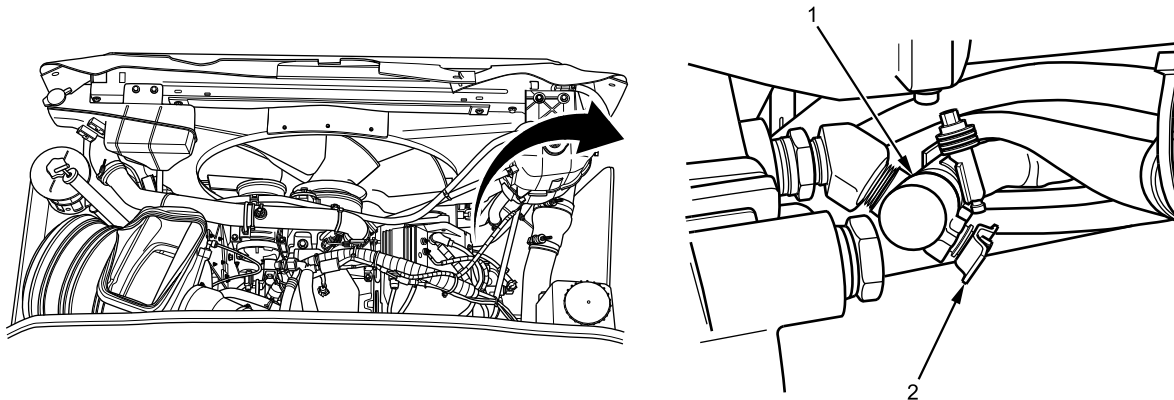

Figure 7. Heater Coolant Engine Outlet Valve.

5. Open valve (Figure 7, Item 1) by turning handle (Figure 7, Item 2) counterclockwise.
6. Install new cable lock strap (Figure 7, Item 3).

HEATING VENTILATING AND AIR CONDITIONING (HVAC) CABIN HEATER HOSE REMOVAL AND INSTALLATION - (CONTINUED)



B235203108

Figure 8. Heater Coolant Engine Inlet Valve.

7. Open valve (Figure 8, Item 1) by turning handle (Figure 8, Item 2) counterclockwise.
8. Install all cable lock straps and tighten securely.
9. Remove drain pan.

END OF TASK

FOLLOW-ON MAINTENANCE

1. Fill cooling system (WP 0277).
2. Turn MAIN POWER switch on (TM 9-2355-106-10).
3. Turn engine on (TM 9-2355-106-10).
4. Verify correct HVAC system operation (TM 9-2355-106-10).
5. Turn engine off (TM 9-2355-106-10).
6. Turn MAIN POWER switch off (TM 9-2355-106-10).
7. Close and secure engine hood (TM 9-2355-106-10).
8. Remove wheel chocks (TM 9-2355-106-10).

END OF TASK

END OF WORK PACKAGE

FIELD MAINTENANCE
**HEATING VENTILATING AND AIR CONDITIONING (HVAC) FUEL-FIRED HEATER COOLANT OUTLET HOSE
REMOVAL AND INSTALLATION**

INITIAL SETUP:**Tools and Special Tools**

General Mechanic's Tool Kit (GMTK)
(WP 0795, Item 37)
Pan, drain, 5 gal. capacity (WP 0795, Item 75)

WP 0277

WP 0782

Materials/Parts

Gloves (WP 0794, Item 19)
Goggles, industrial (WP 0794, Item 20)
Wire (WP 0794, Item 57)
Cable lock strap - (6) (WP 0796, Item 120)
Clamp - (2) (WP 0796, Item 140)

Equipment Condition

Parking brake set (TM 9-2355-106-10)
Transmission set in NEUTRAL (N) (TM
9-2355-106-10)
Engine off (TM 9-2355-106-10)
MAIN POWER switch off (TM 9-2355-106-10)
Wheels chocked (TM 9-2355-106-10)
Engine hood open and secured (TM 9-2355-106-10)
Batteries disconnected (WP 0404)
Right AC condenser panel removed (WP 0672)
Right engine armor plate removed (WP 0599)

References

TM 9-2355-106-10
TM 9-2355-106-23P

WARNING

Engine hood is extremely heavy and requires two-person lift. Ensure that there is adequate space in front of the vehicle to open hood completely without pinning or pinching personnel between hood and any other structure. Use extreme care when working under hood and make sure it is properly supported. Failure to comply may result in serious injury or death to personnel.

Engine components become extremely hot during normal operation. Allow engine to cool completely prior to performing maintenance. Use extreme care when working in close quarters in engine compartment. Stay clear of rotating parts. Wear safety goggles, work gloves, and long sleeves or shop coat. Failure to comply may result in serious injury or death to personnel.

HEATING VENTILATING AND AIR CONDITIONING (HVAC) FUEL-FIRED HEATER COOLANT OUTLET HOSE REMOVAL AND INSTALLATION - (CONTINUED)

REMOVAL

1. Remove and discard cable lock strap (Figure 1, Item 3).

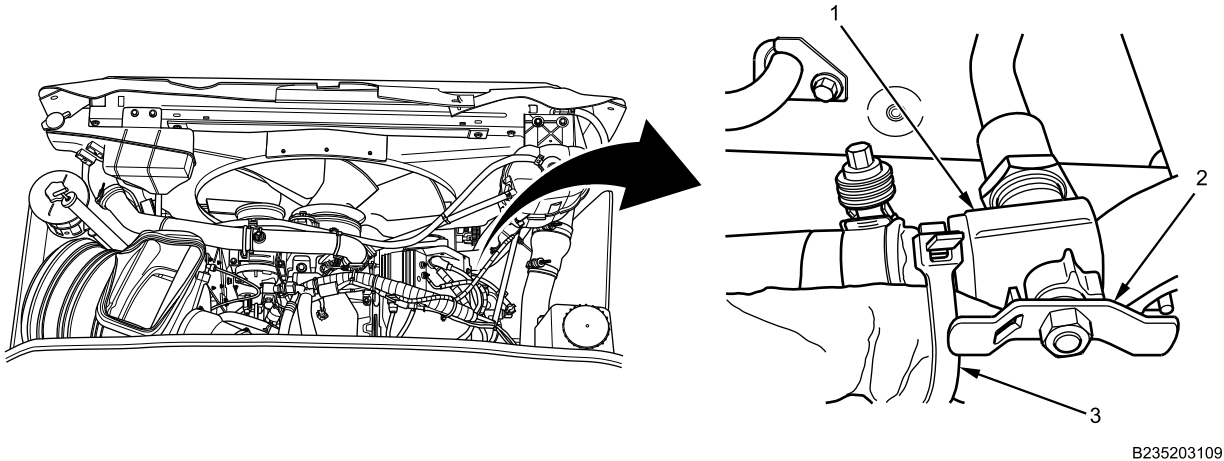

B235203109

Figure 1. Heater Coolant Engine Outlet Valve.

2. Close heater coolant engine outlet valve (Figure 1, Item 1) by turning valve handle (Figure 1, Item 2) clockwise.
3. Close heater coolant engine inlet valve (Figure 2, Item 1) by turning valve handle (Figure 2, Item 5) clockwise.

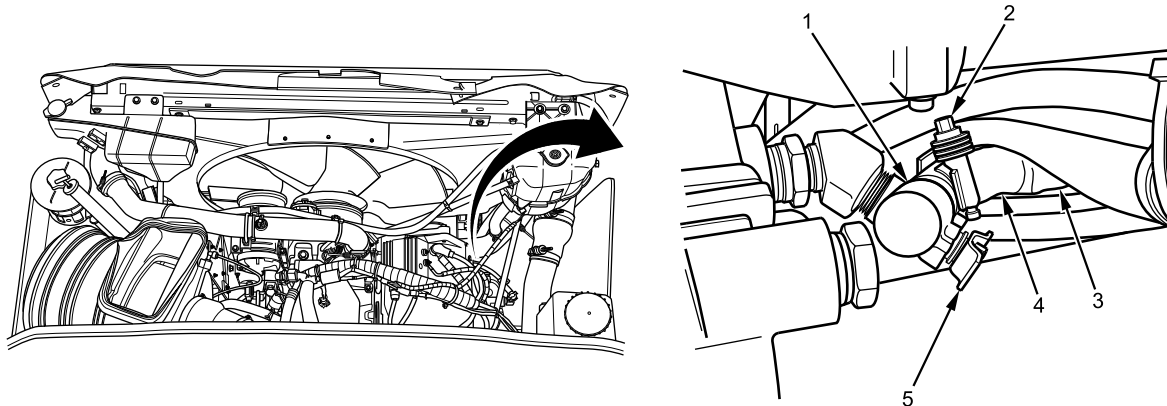

B235203271

Figure 2. Heater Coolant Engine Inlet Valve.

4. Position drain pan under engine inlet valve (Figure 2, Item 1).
5. Loosen clamp (Figure 2, Item 2) and disconnect fuel-fired heater inlet hose (Figure 2, Item 4) and heat shielding (Figure 2, Item 3) from valve (Figure 2, Item 1). Allow coolant to drain into drain pan. Remove and discard clamp (Figure 2, Item 2) from fuel-fired heater inlet hose.
6. Disconnect fuel-fired heater harness connection (Figure 3, Item 5) and set aside.

HEATING VENTILATING AND AIR CONDITIONING (HVAC) FUEL-FIRED HEATER COOLANT OUTLET HOSE REMOVAL AND INSTALLATION - (CONTINUED)

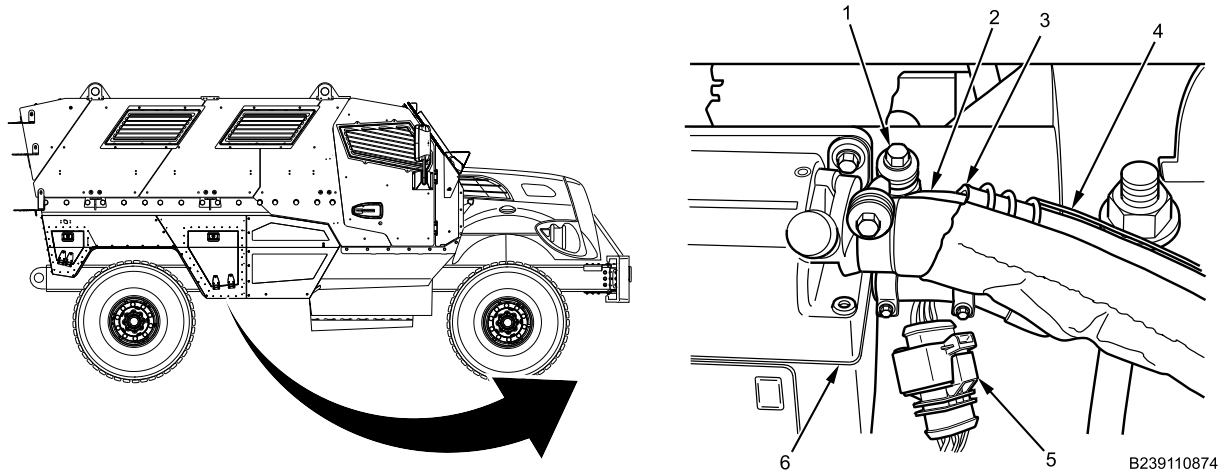

Figure 3. Hose Connections at Fuel-Fired Heater.

7. Loosen clamp (Figure 3, Item 1) and disconnect fuel-fired heater outlet hose (Figure 3, Item 2) and heat shielding (Figure 3, Item 3) from fuel-fired heater (Figure 3, Item 6). Remove and discard clamp (Figure 3, Item 1) from fuel-fired heater outlet hose.
8. Securely connect mechanic's wire (Figure 3, Item 4) to end of fuel-fired heater outlet hose (Figure 3, Item 2) near fuel-fired heater (Figure 3, Item 6).
9. From engine compartment, pull fuel-fired heater outlet hose (Figure 3, Item 2), heat shielding (Figure 3, Item 3), and mechanic's wire (Figure 3, Item 4) into engine compartment. Remove and discard cable strap locks as necessary. Disconnect mechanic's wire (Figure 3, Item 4) from fuel-fired heater outlet hose.
10. Remove heat shielding (Figure 3, Item 3) from fuel-fired heater outlet hose (Figure 3, Item 2).

END OF TASK

INSTALLATION

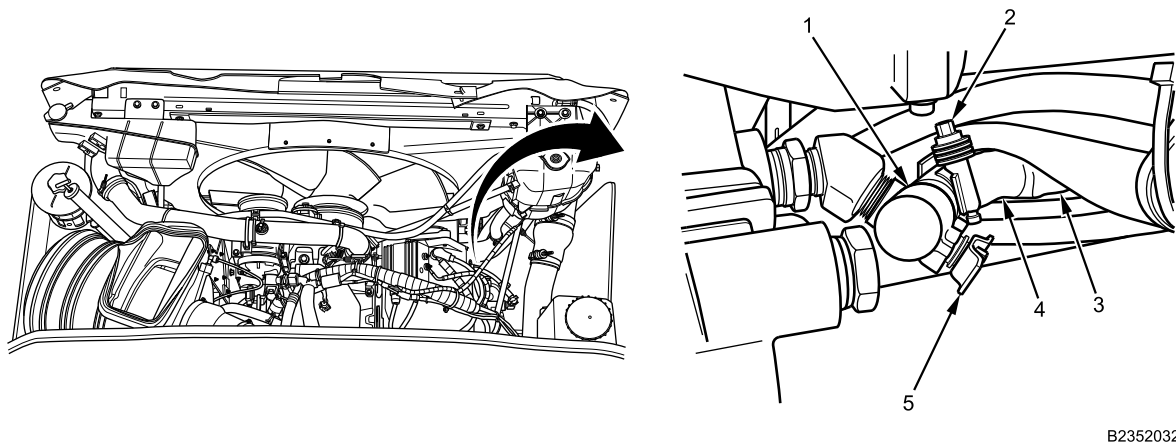
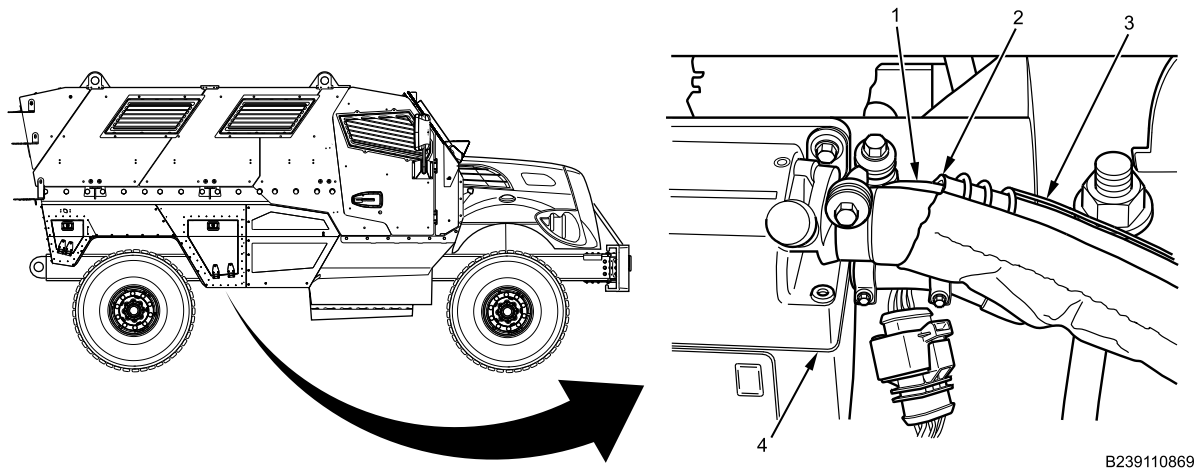

Figure 4. Fuel-Fired Heater Outlet Hose.

1. Install heat shielding (Figure 4, Item 4) on fuel-fired heater outlet hose (Figure 4, Item 2).

HEATING VENTILATING AND AIR CONDITIONING (HVAC) FUEL-FIRED HEATER COOLANT OUTLET HOSE REMOVAL AND INSTALLATION - (CONTINUED)

- Securely tie end of mechanic's wire (Figure 5, Item 3) at engine compartment to fuel-fired heater outlet hose (Figure 5, Item 1).



B239110869

Figure 5. Fuel-Fired Heater Outlet Hose.

- From fuel-fired heater (Figure 5, Item 4), pull mechanic's wire (Figure 5, Item 3), fuel-fired heater outlet hose (Figure 5, Item 1), and heat shielding (Figure 5, Item 2) to fuel-fired heater. Disconnect mechanic's wire from fuel-fired heater outlet hose.
- Position new clamp (Figure 6, Item 1) on end of fuel-fired heater outlet hose (Figure 6, Item 2).

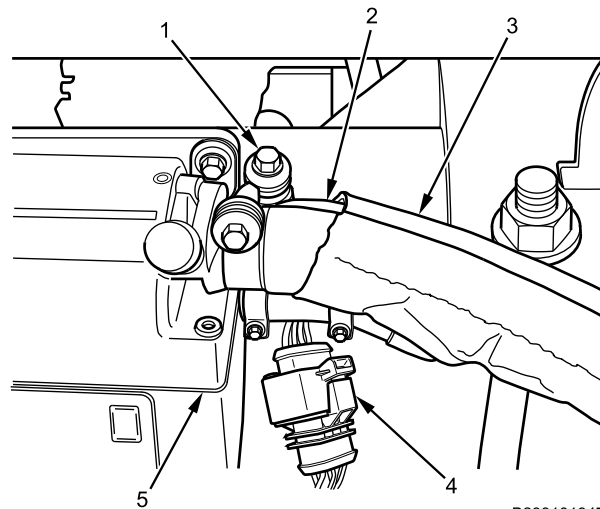

B239101947

Figure 6. Hose Connections at Fuel-Fired Heater.

- Connect fuel-fired heater outlet hose (Figure 6, Item 2) and heat shielding (Figure 6, Item 3) to fuel-fired heater (Figure 6, Item 5) with clamp (Figure 6, Item 1) and tighten securely.
- Connect fuel-fired heater harness connection (Figure 6, Item 4).

HEATING VENTILATING AND AIR CONDITIONING (HVAC) FUEL-FIRED HEATER COOLANT OUTLET HOSE REMOVAL AND INSTALLATION - (CONTINUED)

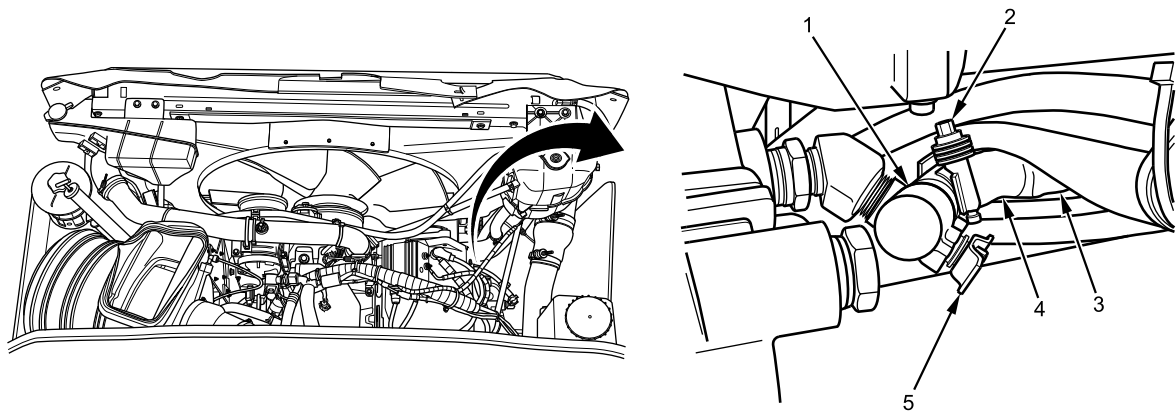

B235203271

Figure 7. Heater Coolant Engine Inlet Valve Installation.

7. Position new clamp (Figure 7, Item 2) on fuel-fired outlet hose (Figure 7, Item 4).
8. Connect fuel-fired outlet hose (Figure 7, Item 4) and heat shielding (Figure 7, Item 3) to valve (Figure 7, Item 1) with clamp (Figure 7, Item 2) and tighten securely.
9. Open heater coolant engine valve (Figure 7, Item 1) by turning valve handle (Figure 7, Item 5) counterclockwise.
10. Open heater coolant engine outlet valve (Figure 8, Item 1) by turning valve handle (Figure 8, Item 2) counterclockwise.

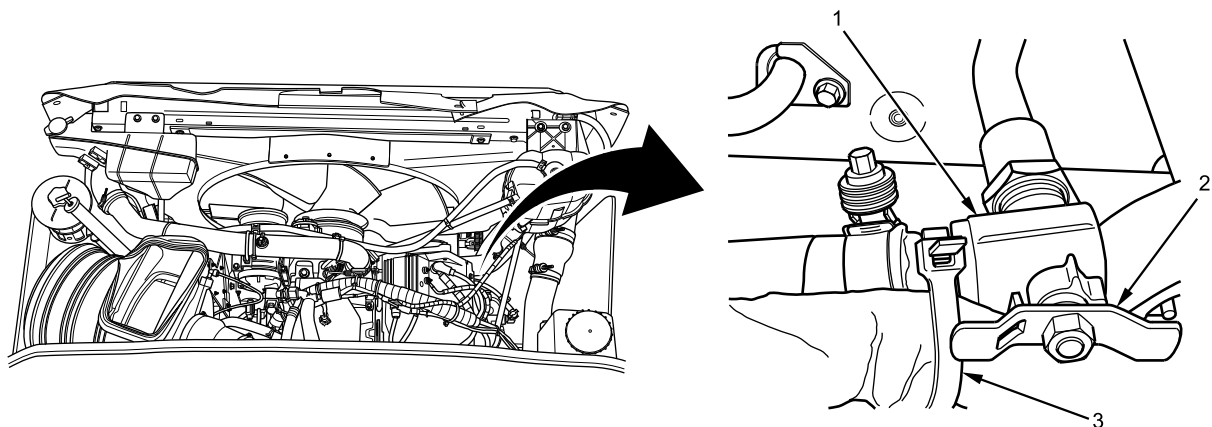

B235203109

Figure 8. Heater Coolant Engine Outlet Valve.

11. Remove drain pan.
12. Install new cable lock straps (Figure 8, Item 3) where removed.

END OF TASK

**HEATING VENTILATING AND AIR CONDITIONING (HVAC) FUEL-FIRED HEATER COOLANT OUTLET HOSE
REMOVAL AND INSTALLATION - (CONTINUED)****FOLLOW-ON MAINTENANCE**

1. Fill cooling system (WP 0277).
2. Install right A/C condenser panel (WP 0672).
3. Install right engine armor plate (WP 0599).
4. Turn MAIN POWER switch on (TM 9-2355-106-10).
5. Verify correct HVAC operation (TM 9-2355-106-10).
6. Turn MAIN POWER switch off (TM 9-2355-106-10).
7. Close and secure engine hood (TM 9-2355-106-10).
8. Remove wheel chocks (TM 9-2355-106-10).

END OF TASK**END OF WORK PACKAGE**

FIELD MAINTENANCE

HEATING VENTILATING AND AIR CONDITIONING (HVAC) 3-WAY VALVE COOLANT INLET HOSE REMOVAL AND INSTALLATION

INITIAL SETUP:

Tools and Special Tools

General Mechanic's Tool Kit (GMTK)
(WP 0795, Item 37)
Pan, drain, 5 gal. capacity (WP 0795, Item 75)

TM 9-2355-106-23P
WP 0786
WP 0782

Materials/Parts

Cable lock strap - (6) (WP 0796, Item 120)
Clamp - (2) (WP 0796, Item 140)
Goggles, industrial (WP 0794, Item 20)
Gloves (WP 0794, Item 19)

Equipment Condition

Parking brake set (TM 9-2355-106-10)
Transmission set in NEUTRAL (N) (TM 9-2355-106-10)
Engine off (TM 9-2355-106-10)
MAIN POWER switch off (TM 9-2355-106-10)
Wheels chocked (TM 9-2355-106-10)
Engine hood open and secured (TM 9-2355-106-10)
Right side engine armor plate removed (WP 0599)

References

TM 9-2355-106-10

REMOVAL

WARNING



Engine hood is extremely heavy and requires two-person lift. Ensure that there is adequate space in front of the vehicle to open hood completely without pinning or pinching personnel between hood and any other structure. Use extreme care when working under hood and make sure it is properly supported. Failure to comply may result in serious injury or death to personnel.

Engine components become extremely hot during normal operation. Allow engine to cool completely prior to performing maintenance. Use extreme care when working in close quarters in engine compartment. Stay clear of rotating parts. Wear safety goggles, work gloves, and long sleeves or shop coat. Failure to comply may result in serious injury or death to personnel.

HEATING VENTILATING AND AIR CONDITIONING (HVAC) 3-WAY VALVE COOLANT INLET HOSE REMOVAL AND INSTALLATION - (CONTINUED)

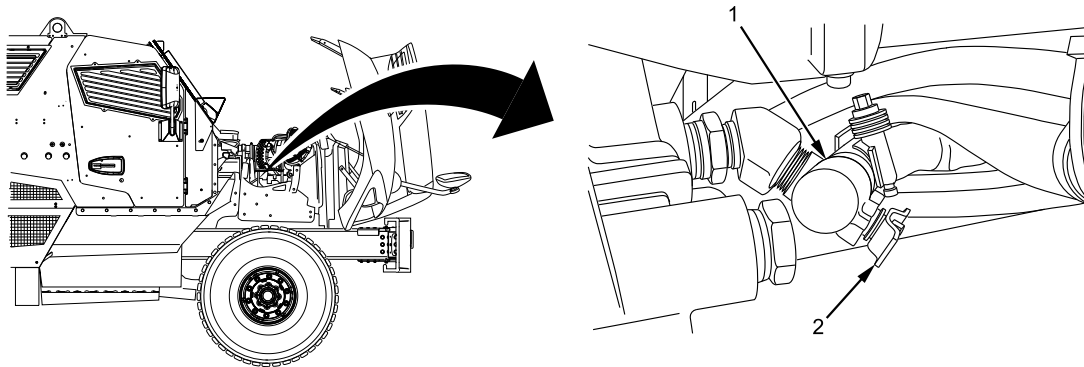

B239110866

Figure 1. Inlet Valve To Water Pump From Heater.

1. Close inlet valve (Figure 1, Item 1) by turning handle (Figure 1, Item 2) clockwise.

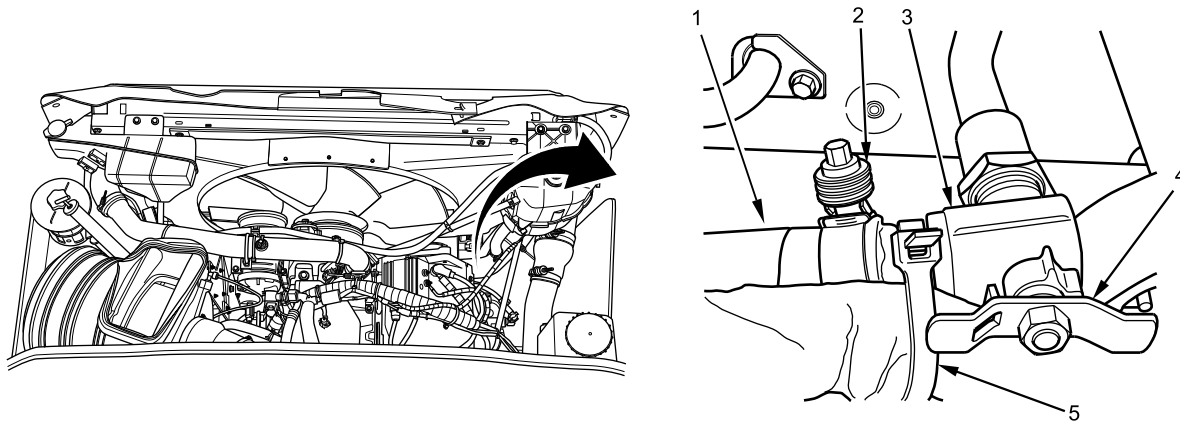

B235210868

Figure 2. Inlet Hose To Engine From Heater.

2. Position drain pan under inlet valve (Figure 2, Item 3).
3. Remove and discard cable lock straps (Figure 2, Item 5) as necessary.
4. Close inlet valve (Figure 2, Item 3) by turning inlet valve handle (Figure 2, Item 4) clockwise.
5. Loosen clamp (Figure 2, Item 2) and disconnect hose (Figure 2, Item 1) from inlet valve (Figure 2, Item 3). Allow coolant to drain into drain pan. Remove clamp from hose. Discard clamp.

HEATING VENTILATING AND AIR CONDITIONING (HVAC) 3-WAY VALVE COOLANT INLET HOSE REMOVAL AND INSTALLATION - (CONTINUED)

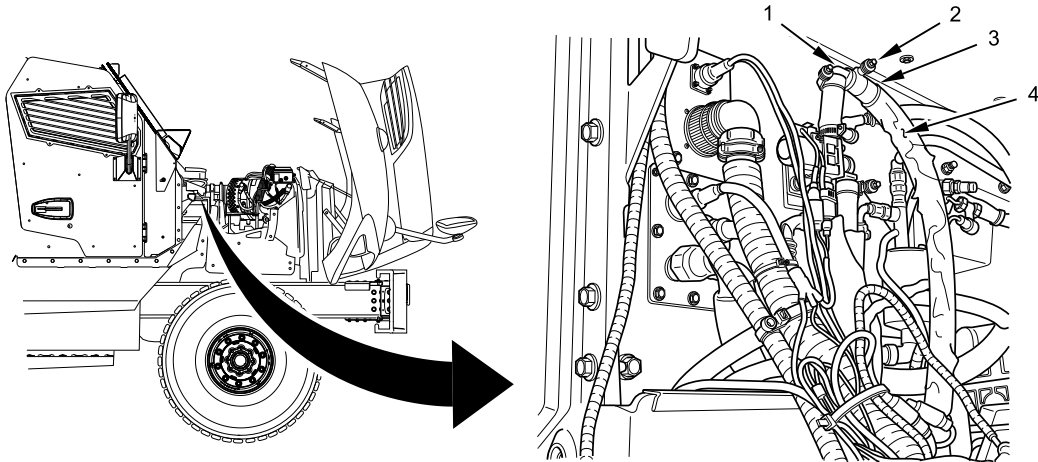

B235210867

Figure 3. 3-Way Valve.

6. Loosen clamp (Figure 3, Item 2) and disconnect hose (Figure 3, Item 3) from elbow (Figure 3, Item 1). Remove hose. Remove clamp from hose. Discard clamp.
7. Remove heat shielding (Figure 3, Item 4) from hose (Figure 3, Item 3).

END OF TASK

INSTALLATION

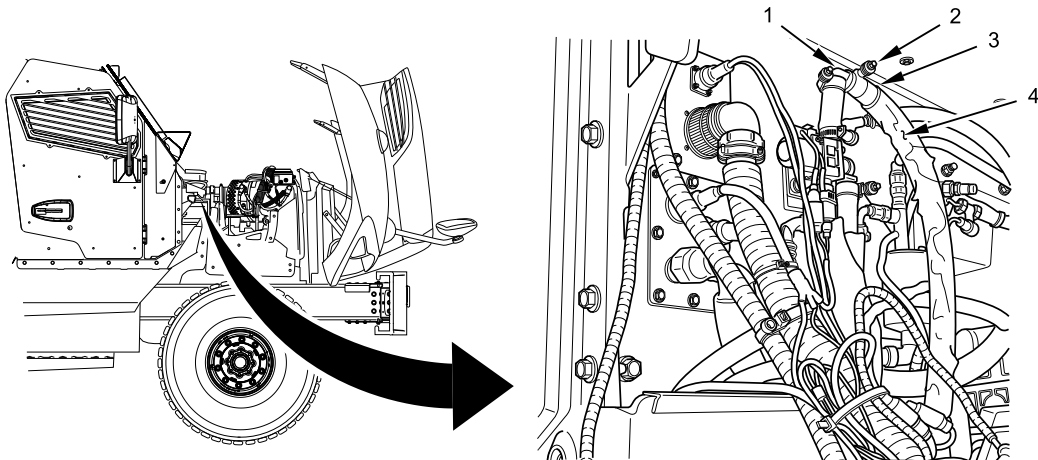

B235210867

Figure 4. 3-Way Valve.

1. Install heat shielding (Figure 4, Item 4) on hose (Figure 4, Item 3).
2. Position new clamp (Figure 4, Item 2) on hose (Figure 4, Item 3).
3. Connect hose (Figure 4, Item 3) to elbow (Figure 4, Item 1) with clamp (Figure 4, Item 2) and tighten securely.

HEATING VENTILATING AND AIR CONDITIONING (HVAC) 3-WAY VALVE COOLANT INLET HOSE REMOVAL AND INSTALLATION - (CONTINUED)

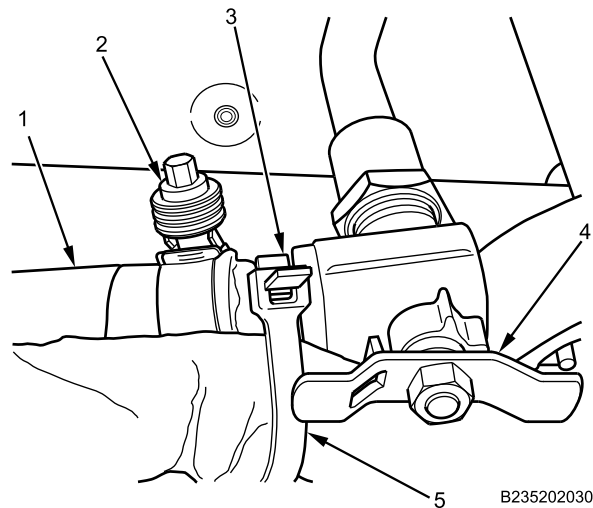

Figure 5. Inlet Hose To Engine From Heater.

4. Position new clamp (Figure 5, Item 2) on hose (Figure 5, Item 1).
5. Connect hose (Figure 5, Item 1) to inlet valve (Figure 5, Item 3) and tighten clamp (Figure 5, Item 2) securely.
6. Open inlet valve (Figure 5, Item 3) by turning inlet valve handle (Figure 5, Item 4) counterclockwise.
7. Install new cable lock straps (Figure 5, Item 5) where removed.

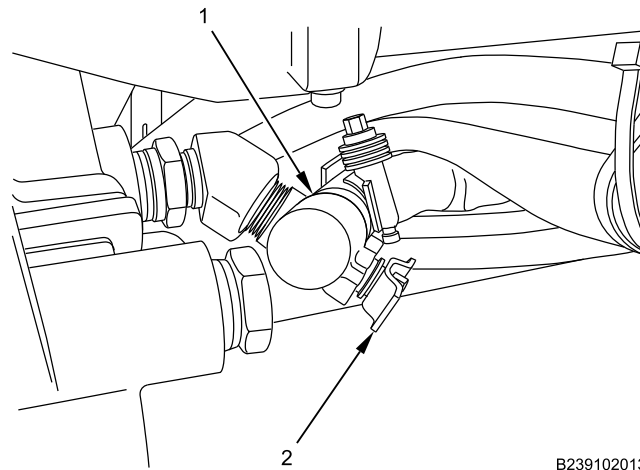

Figure 6. Inlet Valve To Water Pump From Heater.

8. Open inlet valve (Figure 6, Item 1) by turning handle (Figure 6, Item 2) counterclockwise.
9. Remove drain pan.

END OF TASK

FOLLOW-ON MAINTENANCE

1. Fill cooling system (WP 0277).
2. Install right side engine armor plate (WP 0599).
3. Close and secure engine hood (TM 9-2355-106-10).

HEATING VENTILATING AND AIR CONDITIONING (HVAC) 3-WAY VALVE COOLANT INLET HOSE REMOVAL AND INSTALLATION - (CONTINUED)

4. Remove wheel chocks (TM 9-2355-106-10).

END OF TASK**END OF WORK PACKAGE**

FIELD MAINTENANCE

HEATING VENTILATING AND AIR CONDITIONING (HVAC) FUEL-FIRED HEATER COOLANT INLET HOSE
REMOVAL AND INSTALLATION

INITIAL SETUP:

Tools and Special Tools

General Mechanic's Tool Kit (GMTK)
(WP 0795, Item 37)
Pan, drain, 5 gal. capacity (WP 0795, Item 75)

Materials/Parts

Wire (WP 0794, Item 57)
Cable lock strap - (6) (WP 0796, Item 120)
Clamp, screw - (5) (WP 0796, Item 140)

References

TM 9-2355-106-10
TM 9-2355-106-23P
WP 0277

WP 0782

Equipment Condition

Parking brake set (TM 9-2355-106-10)
Transmission set in NEUTRAL (N) (TM
9-2355-106-10)
Engine off (TM 9-2355-106-10)
MAIN POWER switch off (TM 9-2355-106-10)
Wheels chocked (TM 9-2355-106-10)
Engine hood open and secured (TM 9-2355-106-10)
Batteries disconnected (WP 0404)
Right A/C condenser panel removed (WP 0672)
Right side engine armor plate removed (WP 0599)

REMOVAL

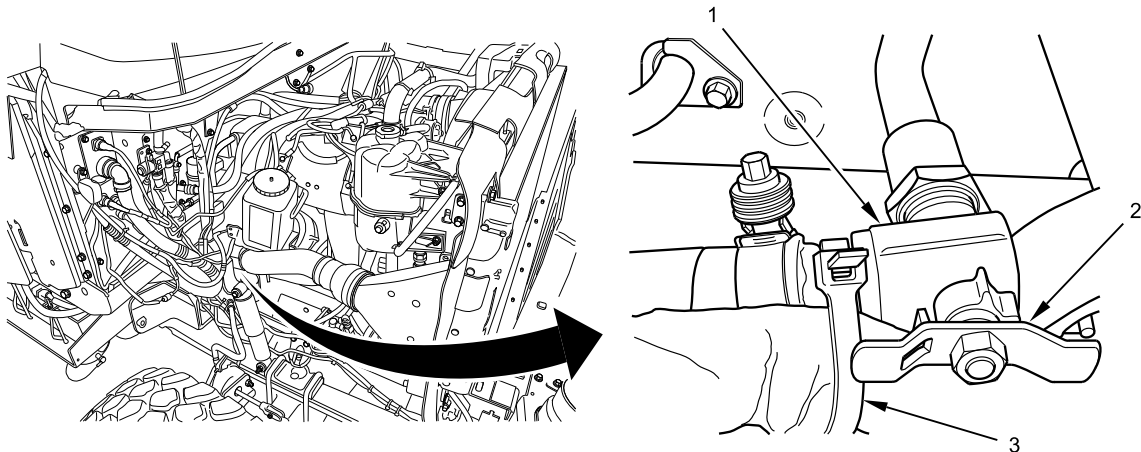

B230610882

Figure 1. Heater Coolant Engine Outlet Valve.

1. Close outlet valve (Figure 1, Item 1) by turning handle (Figure 1, Item 2) clockwise. Remove and discard cable lock strap (Figure 1, Item 3) if necessary.

HEATING VENTILATING AND AIR CONDITIONING (HVAC) FUEL-FIRED HEATER COOLANT INLET HOSE REMOVAL AND INSTALLATION - (CONTINUED)

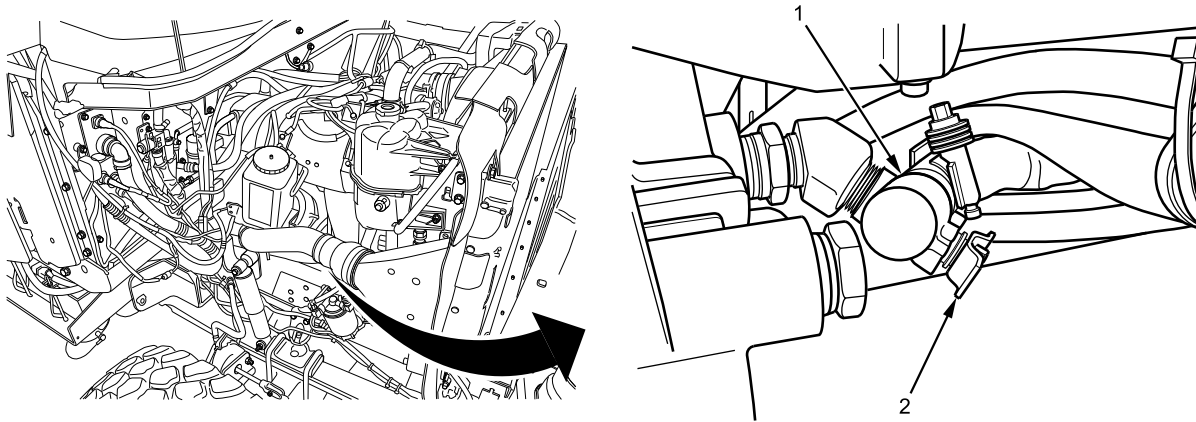

B230610881

Figure 2. Heater Coolant Engine Inlet Valve.

2. Close inlet valve (Figure 2, Item 1) by turning handle (Figure 2, Item 2) clockwise.
3. Position drain pan under fuel-fired heater hose connections.
4. Disconnect harness connector (Figure 3, Item 4) and set aside.

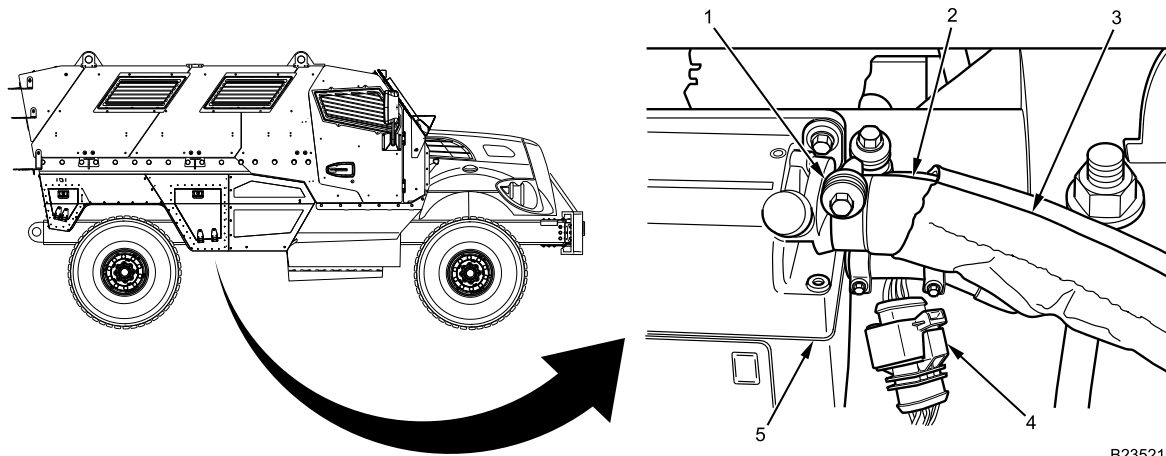

B235210879

Figure 3. Fuel-Fired Heater Hose Connections.

5. Loosen clamp (Figure 3, Item 1) and disconnect hose (Figure 3, Item 2) and heat shielding (Figure 3, Item 3) from fuel-fired heater (Figure 3, Item 5). Allow coolant to drain into drain pan. Remove and discard clamp (Figure 3, Item 1) from hose (Figure 3, Item 2).

HEATING VENTILATING AND AIR CONDITIONING (HVAC) FUEL-FIRED HEATER COOLANT INLET HOSE REMOVAL AND INSTALLATION - (CONTINUED)

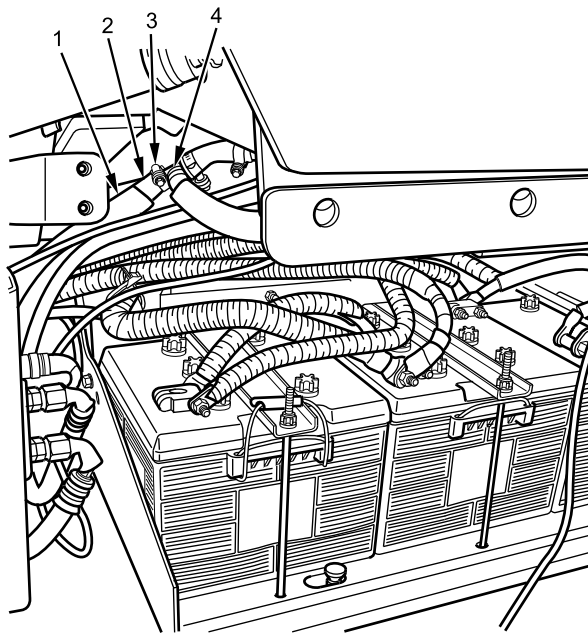

B235210872

Figure 4. Fuel-Fired Heater Inlet Hose at Penetration Dust Plate.

6. Loosen clamp (Figure 4, Item 3), disconnect hose (Figure 4, Item 2) and heat shielding (Figure 4, Item 1) from tee (Figure 4, Item 4), and remove hose and heat shielding (Figure 4, Item 1). Remove and discard clamp (Figure 4, Item 3) and heat shielding (Figure 4, Item 1) from hose.

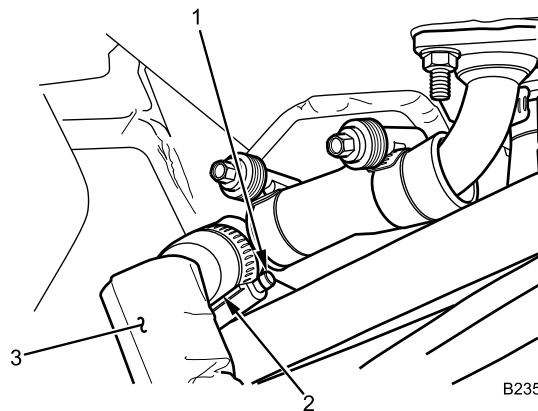

B235210871

Figure 5. Fuel-Fired Heater Hose Tee.

7. Loosen clamp (Figure 5, Item 1) and disconnect hose (Figure 5, Item 2) and heat shielding (Figure 5, Item 3) from tee.
8. Securely connect mechanic's wire to hose (Figure 5, Item 2).

HEATING VENTILATING AND AIR CONDITIONING (HVAC) FUEL-FIRED HEATER COOLANT INLET HOSE REMOVAL AND INSTALLATION - (CONTINUED)

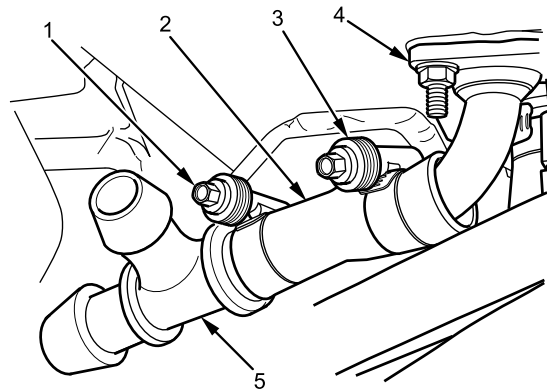

B235210870

Figure 6. Fuel-Fired Hose Tee and Dust Plate.

9. Loosen clamps (Figure 6, Item 1 and 3) and separate hose (Figure 6, Item 2) from tee (Figure 6, Item 5) and dust plate (Figure 6, Item 4).

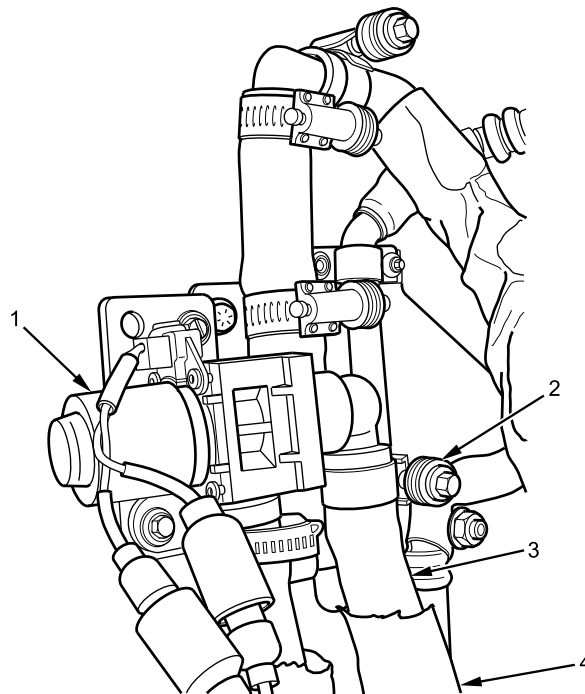

B235210873

Figure 7. Fuel-Fired Heater Inlet Hose at 3-Way Valve.

10. Loosen clamp (Figure 7, Item 2) and disconnect inlet hose (Figure 7, Item 3) and heat shielding (Figure 7, Item 4) from 3-way valve (Figure 7, Item 1). Remove and discard clamp (Figure 7, Item 2) from hose.
11. Remove and discard cable lock straps as necessary.
12. From engine compartment, pull inlet hose (Figure 7, Item 3), heat shielding, and mechanic's wire to engine compartment. Remove mechanic's wire and heat shield from hose.

END OF TASK

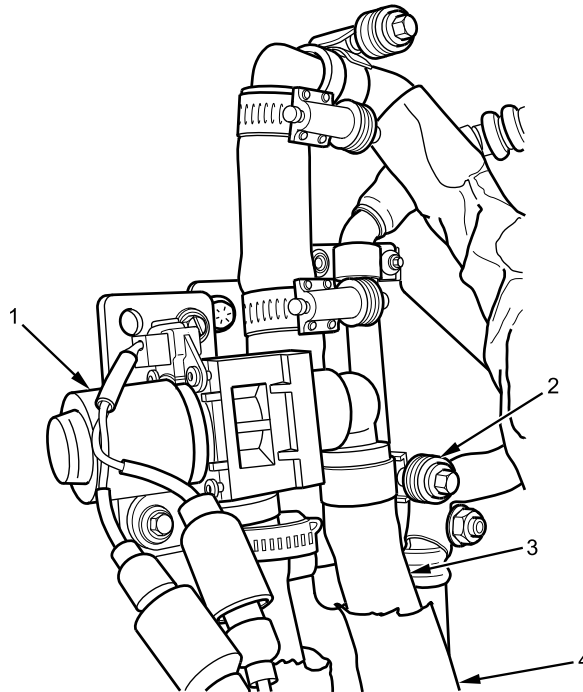
HEATING VENTILATING AND AIR CONDITIONING (HVAC) FUEL-FIRED HEATER COOLANT INLET HOSE REMOVAL AND INSTALLATION - (CONTINUED)**INSTALLATION**

B235210873

Figure 8. Fuel-Fired Heater Inlet Hose at 3-Way Valve.

1. Install heat shielding (Figure 8, Item 4) on inlet hose (Figure 8, Item 3).
2. Securely connect mechanic's wire at engine compartment to inlet hose (Figure 8, Item 3).
3. From dust plate, pull mechanic's wire, inlet hose (Figure 8, Item 2), and heat shielding to dust plate. Remove mechanic's wire.
4. Position new clamp (Figure 8, Item 1) on inlet hose (Figure 8, Item 2).
5. Connect inlet hose (Figure 8, Item 2) and heat shielding (Figure 8, Item 3) to 3-way valve (Figure 8, Item 1) with clamp (Figure 8, Item 2) and tighten securely.

HEATING VENTILATING AND AIR CONDITIONING (HVAC) FUEL-FIRED HEATER COOLANT INLET HOSE REMOVAL AND INSTALLATION - (CONTINUED)

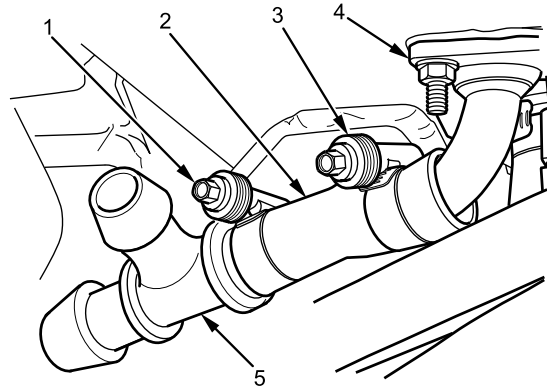

B235210870

Figure 9. Fuel-Fired Heater Inlet Hose at Penetration Dust Plate.

6. Position new clamp (Figure 9, Item 1 and 3) on each end of hose (Figure 9, Item 2).
7. Connect hose (Figure 9, Item 2) to tee and dust plate (Figure 9, Item 4) with clamps (Figure 9, Item 1 and 3) and tighten securely.

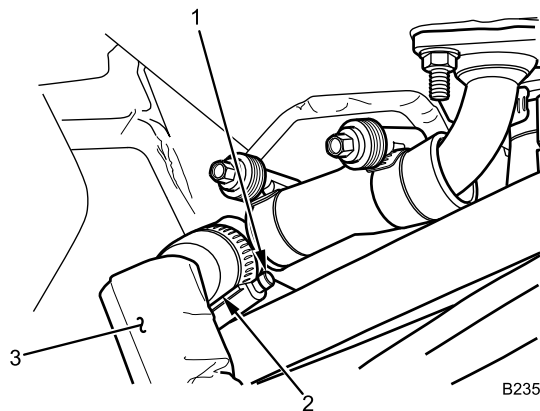

B235210871

Figure 10. Fuel-Fired Heater Hose Tee.

8. Position new clamp (Figure 10, Item 1) on inlet hose (Figure 10, Item 2).
9. Connect inlet hose (Figure 10, Item 2) and heat shielding to tee with clamp (Figure 10, Item 1) and tighten securely.

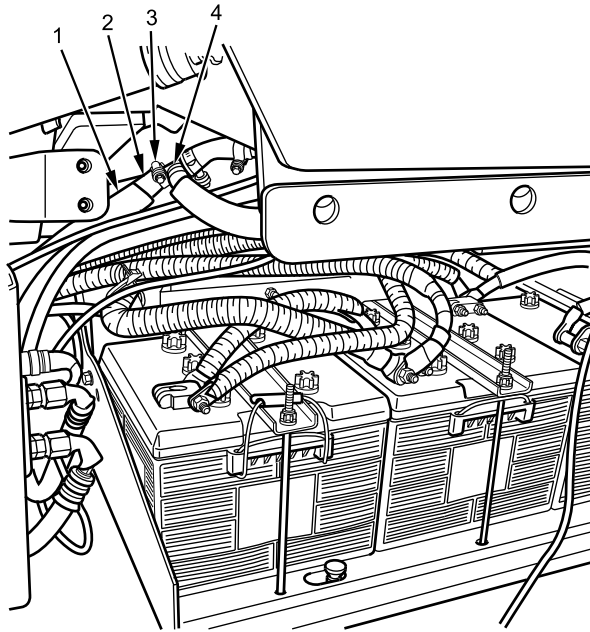
HEATING VENTILATING AND AIR CONDITIONING (HVAC) FUEL-FIRED HEATER COOLANT INLET HOSE REMOVAL AND INSTALLATION - (CONTINUED)

B235210872

Figure 11. Fuel-Fired Heater Inlet Hose.

10. Connect hose (Figure 11, Item 2) and heat shielding (Figure 11, Item 1) to tee (Figure 11, Item 4) with clamp (Figure 11, Item 3) and tighten securely.

HEATING VENTILATING AND AIR CONDITIONING (HVAC) FUEL-FIRED HEATER COOLANT INLET HOSE REMOVAL AND INSTALLATION - (CONTINUED)

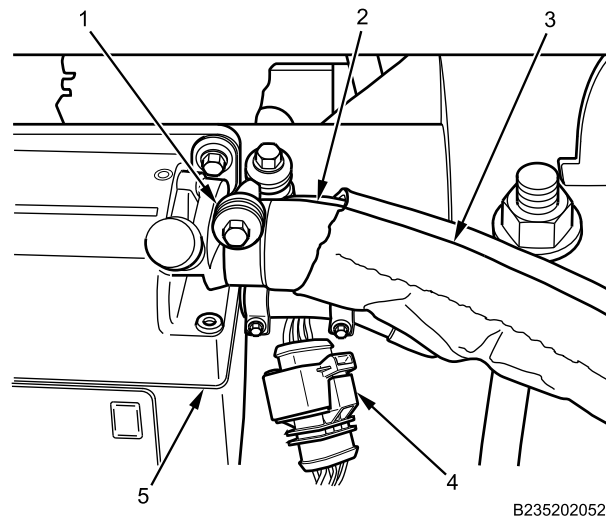

Figure 12. Fuel-Fired Heater Hose Connections.

11. Position new clamp (Figure 12, Item 1) on hose (Figure 12, Item 2).
12. Connect hose (Figure 12, Item 2) and heat shielding (Figure 12, Item 3) to fuel-fired heater (Figure 12, Item 5) with clamp (Figure 12, Item 1) and tighten securely.
13. Connect harness connector (Figure 12, Item 4).
14. Remove drain pan.

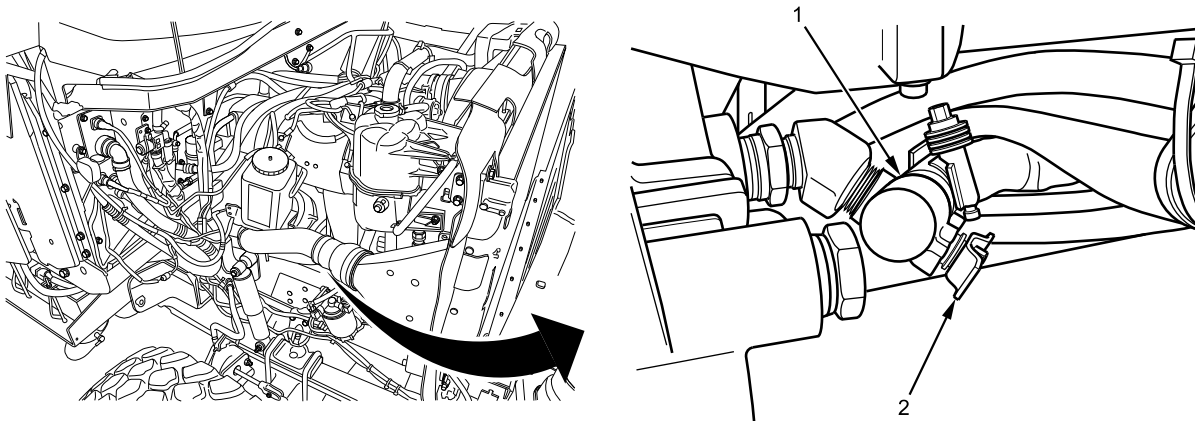
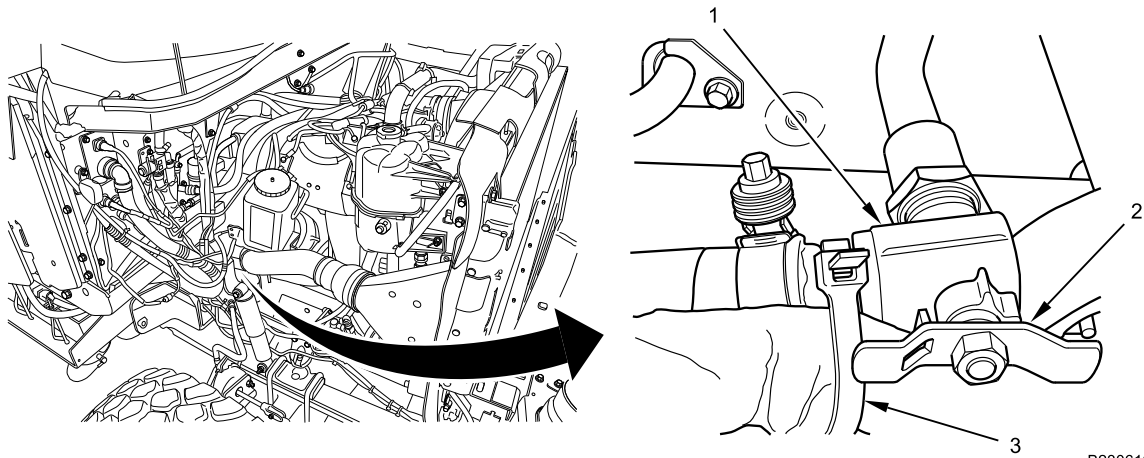

Figure 13. Heater Coolant Engine Inlet Valve.

15. Open valve (Figure 13, Item 1) by turning handle (Figure 13, Item 2) counterclockwise.

HEATING VENTILATING AND AIR CONDITIONING (HVAC) FUEL-FIRED HEATER COOLANT INLET HOSE REMOVAL AND INSTALLATION - (CONTINUED)



B230610882

Figure 14. Heater Coolant Engine Outlet Valve.

16. Open valve (Figure 14, Item 1) by turning handle (Figure 14, Item 2) counterclockwise. Install new cable lock straps (Figure 14, Item 3) where necessary if removed.

END OF TASK

FOLLOW-ON MAINTENANCE

1. Fill cooling system (WP 0277).
2. Install right front vent panel (WP 0672).
3. Install right side engine armor plate (WP 0599).
4. Close battery box cover (TM 9-2355-106-10).
5. Close and secure engine hood (TM 9-2355-106-10).
6. Remove wheel chocks (TM 9-2355-106-10).

END OF TASK

END OF WORK PACKAGE

FIELD MAINTENANCE**FUEL-FIRED HEATER REMOVAL AND INSTALLATION**

INITIAL SETUP:**Tools and Special Tools**

General Mechanic's Tool Kit (GMTK)
(WP 0795, Item 37)
Pan, drain (WP 0795, Item 75)

TM 9-2355-106-23P

WP 0786

WP 0782

Materials/Parts

Compound (WP 0794, Item 13)
Faceshield, industrial (WP 0794, Item 16)
Gloves (WP 0794, Item 19)
Goggles, industrial (WP 0794, Item 20)
Grease (WP 0794, Item 22)
Cable lock strap - (1) (WP 0796, Item 120)

Equipment Condition

Parking brake set (TM 9-2355-106-10)
Transmission set in NEUTRAL (N) (TM
9-2355-106-10)
Engine off (TM 9-2355-106-10)
MAIN POWER switch off (TM 9-2355-106-10)
Wheels chocked (TM 9-2355-106-10)
Engine hood open and secured (TM 9-2355-106-10)
Right air conditioning (A/C) condenser panel
removed (WP 0672)

ReferencesTM 9-2355-106-10

FUEL-FIRED HEATER REMOVAL AND INSTALLATION - (CONTINUED)

WARNING

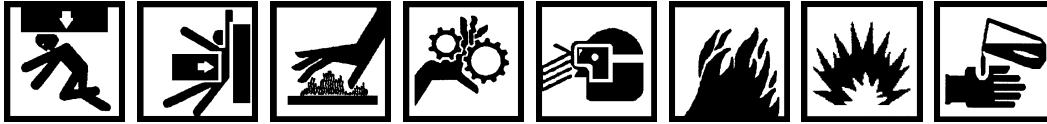

Engine hood is extremely heavy and requires two-person lift. Ensure that there is adequate space in front of the vehicle to open hood completely without pinning or pinching personnel between hood and any other structure. Use extreme care when working under hood and make sure it is properly supported. Failure to comply may result in serious injury or death to personnel.

Engine components become extremely hot during normal operation. Allow engine to cool completely prior to performing maintenance. Use extreme care when working in close quarters in engine compartment. Stay clear of rotating parts. Wear safety goggles, work gloves, and long sleeves or shop coat. Failure to comply may result in serious injury or death to personnel.

Fuel is flammable and can explode. Keep all open flames, flammable materials, ignition sources, and sparks away from diesel fuel and keep fire extinguisher nearby. Do not smoke when working with fuel. Do not work on fuel system when engine is hot. Fuel can be ignited by hot engine. Failure to comply may result in serious injury or death to personnel.

Be alert at all times for the smell of fuel. Hot engines and components can ignite fuel. If fuel smell is detected while operating vehicle, shut down vehicle immediately. Failure to comply may result in damage to equipment and serious injury or death to personnel.

Store diesel fuel in an approved container clearly marked DIESEL FUEL or JP-8, accordingly. Dispose of fuel in an approved container clearly marked DIESEL FUEL or JP-8, accordingly, in accordance with standard operating procedures.

Never use diesel fuel or JP-8 to clean parts. Fuel is highly flammable. Failure to comply may result in damage to equipment and serious injury or death to personnel.

Dispose of used parts, rags, containers, and engine fluids in accordance with standard operating procedures. Failure to comply may result in serious injury to personnel.

Cooling system components become pressurized and extremely hot during normal operation. To prevent serious injury from hot coolant or scalding steam, use the following safety procedure when removing radiator cap, surge tank cap, or deaeration cap:

- Allow engine to cool for 15 minutes.
- Wrap a thick cloth around cap to be removed.
- Loosen cap slowly one-quarter to one-half turn counterclockwise, and pause to allow pressure to release.
- Continue to turn cap counterclockwise to remove.
- Ensure all personnel stay clear of radiator while engine is running. Air in radiator will be released, which may cause hot coolant to spray out. Failure to comply may result in serious injury to personnel.

Wear safety goggles and work gloves while servicing cooling system. Label all connections and reference areas before removing parts. Failure to comply may result in damage to equipment and serious injury or death to personnel.

FUEL-FIRED HEATER REMOVAL AND INSTALLATION - (CONTINUED)

NOTE

Remove cable lock straps as necessary to perform procedure. Note position and size of cable lock straps to aid installation.

REMOVAL

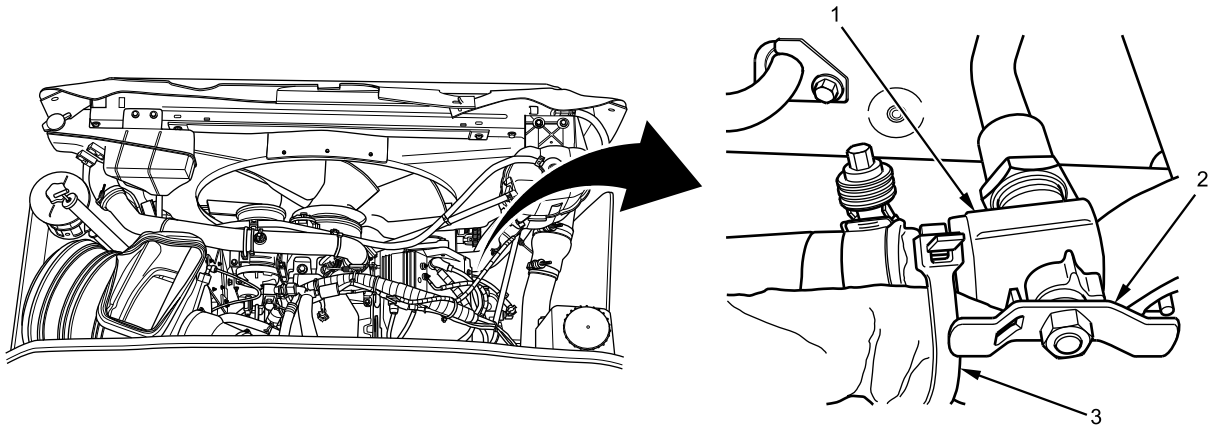

B235203109

Figure 1. Heater Coolant Engine Outlet Valve.

1. Close outlet valve (Figure 1, Item 1) by turning handle (Figure 1, Item 2) clockwise. Remove and discard cable lock strap (Figure 1, Item 3) if necessary.

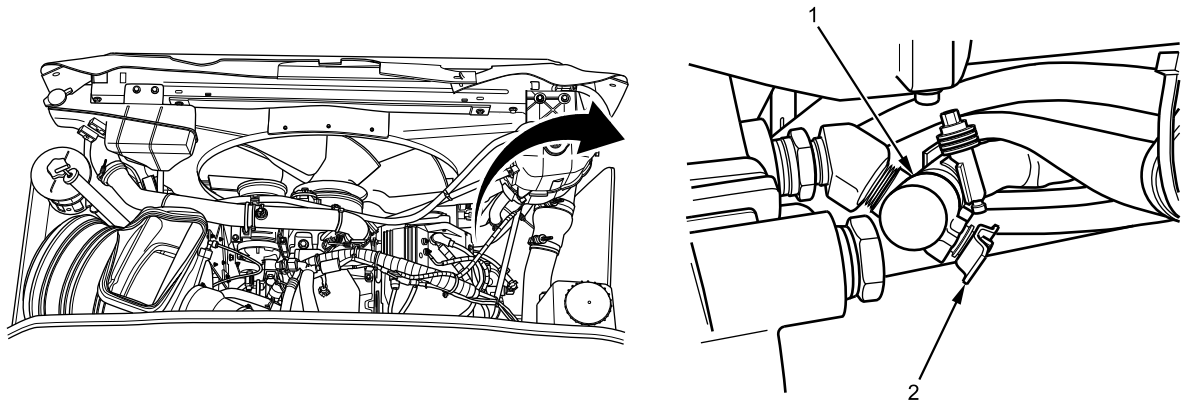

B235203108

Figure 2. Heater Coolant Engine Inlet Valve.

2. Close inlet valve (Figure 2, Item 1) by turning handle (Figure 2, Item 2) clockwise.

FUEL-FIRED HEATER REMOVAL AND INSTALLATION - (CONTINUED)

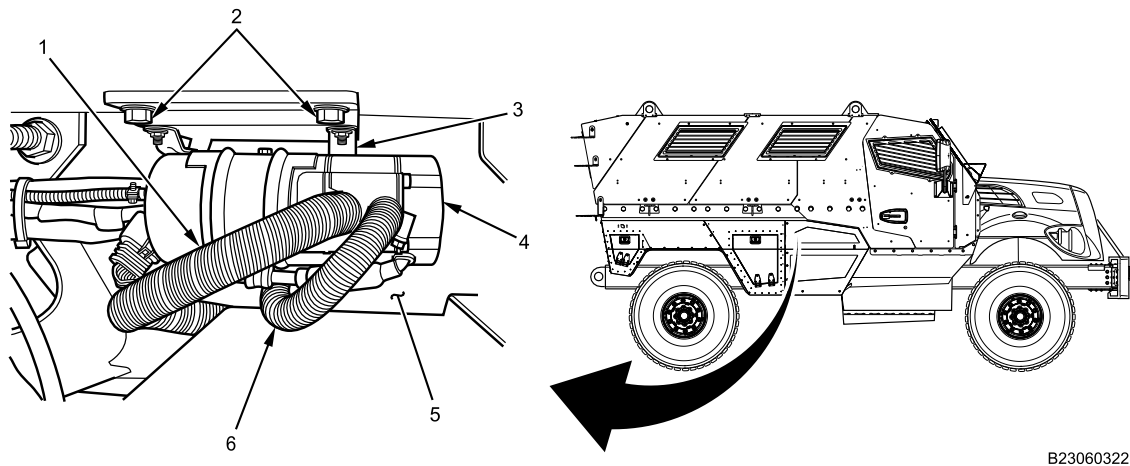

Figure 3. Fuel-Fired Heater Mounted.

NOTE

Label all hoses, lines, and electrical connections before removal of heater.

Plug all hose, line, and heater fluid openings to avoid excess spillage.

3. Loosen clamp on exhaust hose (Figure 3, Item 1) and remove exhaust hose from heater (Figure 3, Item 4).
4. Loosen clamp on intake air hose (Figure 3, Item 6) and remove intake air hose from heater (Figure 3, Item 4).
5. Remove two bolts and nuts (Figure 3, Item 2) from fuel-fired heater support on frame rail (Figure 3, Item 5).

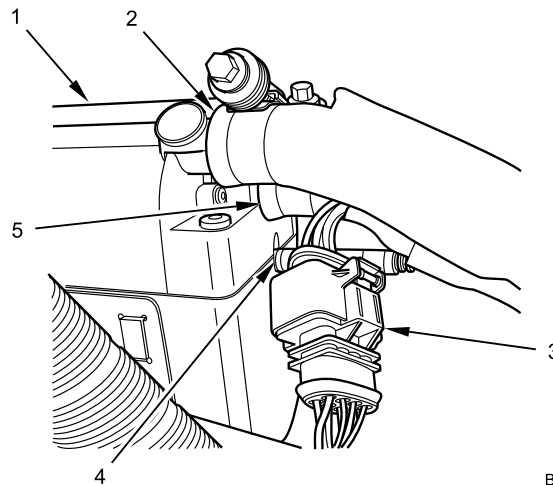
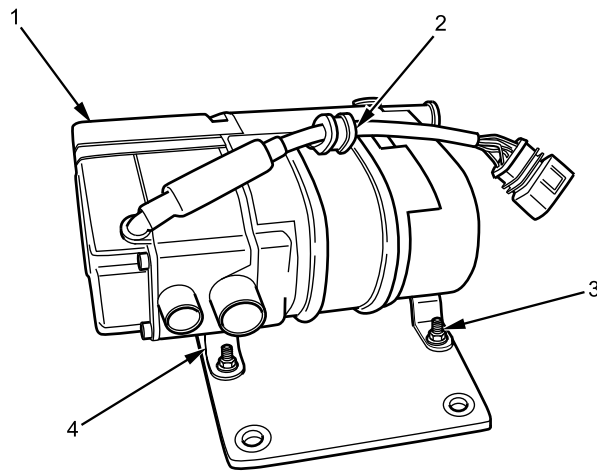

Figure 4. Fuel-Fired Heater Coolant Hoses.

6. Disconnect electrical connector (Figure 4, Item 3) from heater (Figure 4, Item 1).
7. Place drain pan under fuel-fired heater (Figure 4, Item 1)
8. Loosen clamp on coolant inlet hose, (Figure 4, Item 2) and remove coolant inlet hose from heater (Figure 4, Item 1).
9. Loosen clamp on coolant outlet hose, (Figure 4, Item 5) and remove coolant outlet hose from heater (Figure 4, Item 1).
10. Loosen clamp on fuel line, (Figure 4, Item 4) and remove fuel line from heater (Figure 4, Item 1).

FUEL-FIRED HEATER REMOVAL AND INSTALLATION - (CONTINUED)

B230603223

Figure 5. Fuel-Fired Heater.

11. Remove four bolts, nuts, and washers (Figure 5, Item 3) from heater mounting bracket (Figure 5, Item 4). Remove bracket with heater (Figure 5, Item 1) from frame rail.
12. Remove center safety bolt securing heater (Figure 5, Item 1) and wiring harness clamp (Figure 5, Item 2) to mounting bracket (Figure 5, Item 4).

NOTE

There are two center safety bolts. One must be removed (outboard), while the other one (inboard) only needs to be loosened.

13. Loosen second center safety bolt (inboard) and separate heater (Figure 5, Item 1) from bracket.

END OF TASK

FUEL-FIRED HEATER REMOVAL AND INSTALLATION - (CONTINUED)

INSTALLATION

WARNING



Corrosion preventive compound is toxic. Use only in well-ventilated area. Do not get in eyes; wear chemical safety goggles and full faceshield when using. Avoid contact with skin and wear rubber or plastic, solvent-resistant gloves. In case of contact, remove contaminated clothing and immediately wash area with soap and water. If compound contacts eyes, flush eyes with large amounts of water for at least 15 minutes and get immediate medical attention. If swallowed, do not induce vomiting; contact a physician immediately. Failure to comply may result in serious injury or death to personnel.

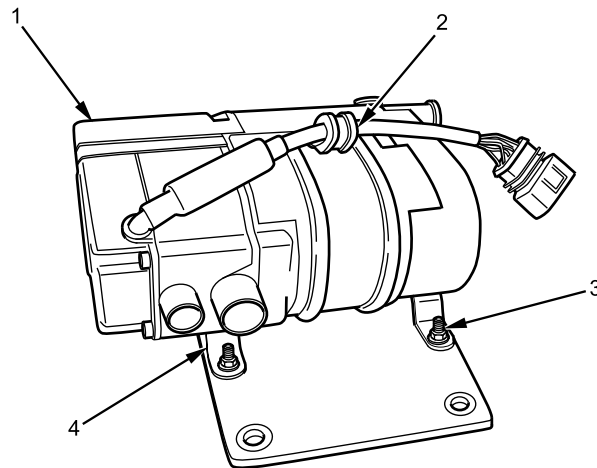

B230603223

Figure 6. Fuel-Fired Heater.

1. Position fuel-fire heater (Figure 6, Item 1) into mounting bracket (Figure 6, Item 4).
2. Install center safety bolt securing heater (Figure 6, Item 1) and wiring harness clamp (Figure 6, Item 2) to mounting bracket (Figure 6, Item 4). Tighten second safety bolt securely (bolt is hidden).
3. Apply corrosion preventive compound on four fuel-fired heater bracket mounting bolts.
4. Install fuel-fired heater (Figure 6, Item 1) with mounting bracket (Figure 6, Item 4) on support bracket with four bolts, nuts, and washers (Figure 6, Item 3). Tighten bolts securely.

FUEL-FIRED HEATER REMOVAL AND INSTALLATION - (CONTINUED)

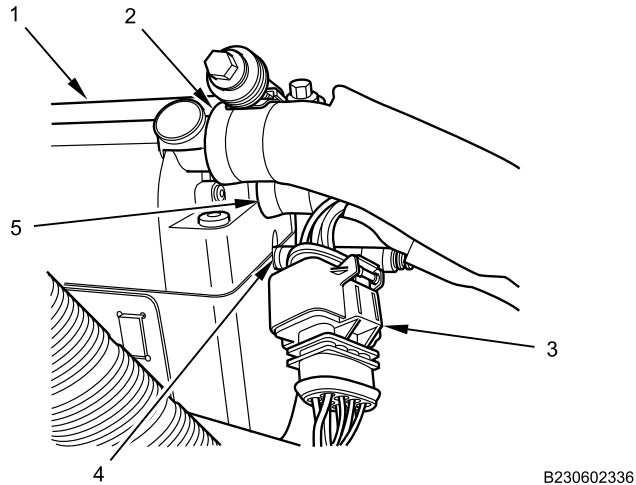

Figure 7. Fuel-Fired Heater Coolant Hoses.

5. Install fuel line (Figure 7, Item 4) on heater (Figure 7, Item 1). Tighten line clamp securely.
6. Install coolant inlet hose (Figure 7, Item 2) on heater (Figure 7, Item 1). Tighten hose clamp securely.
7. Install coolant outlet hose (Figure 7, Item 5) on heater (Figure 7, Item 1). Tighten hose clamp securely.
8. Apply dielectric grease on heater electrical connector (Figure 7, Item 3).
9. Install electrical connector (Figure 7, Item 3) on heater electrical harness.
10. Apply corrosion preventive compound on two fuel-fired heater mounting bolts.

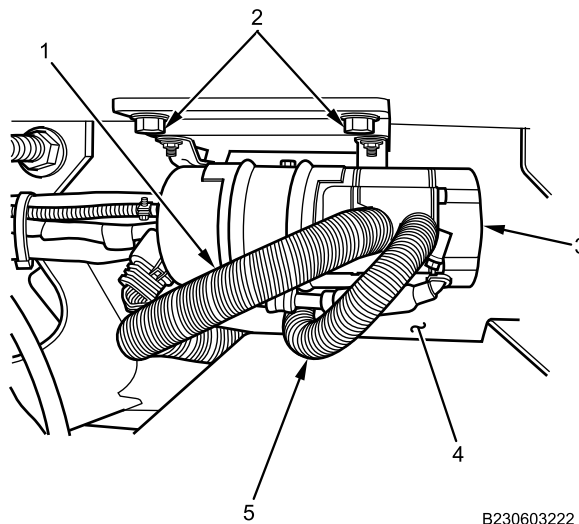
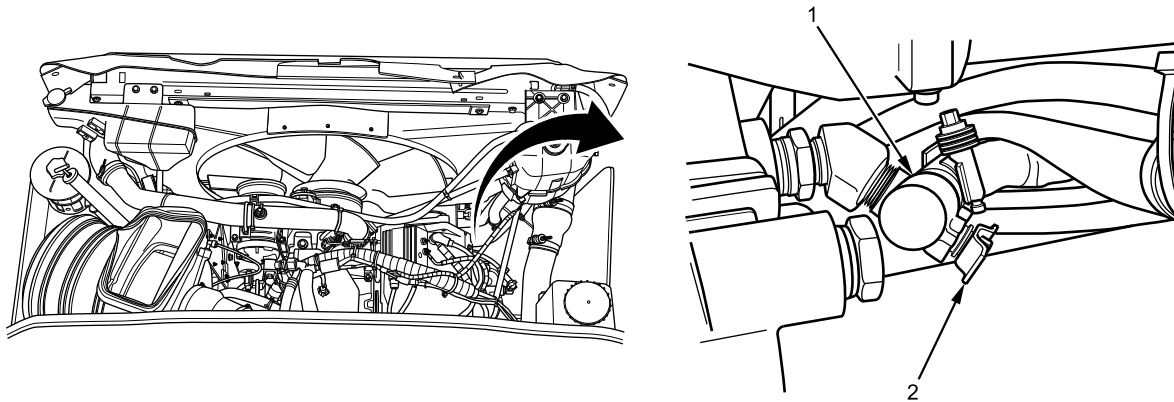

Figure 8. Fuel-Fired Heater Mounted.

11. Install support bracket with two bolts and nuts (Figure 8, Item 2) on frame rail (Figure 8, Item 4).
12. Install intake air hose (Figure 8, Item 5) on heater (Figure 8, Item 3). Tighten hose clamp securely.
13. Install exhaust hose (Figure 8, Item 1) on heater (Figure 8, Item 3). Tighten hose clamp securely.

FUEL-FIRED HEATER REMOVAL AND INSTALLATION - (CONTINUED)



B235203108

Figure 9. Heater Coolant Engine Inlet Valve.

14. Open inlet valve (Figure 9, Item 1) by turning handle (Figure 9, Item 2) counterclockwise.

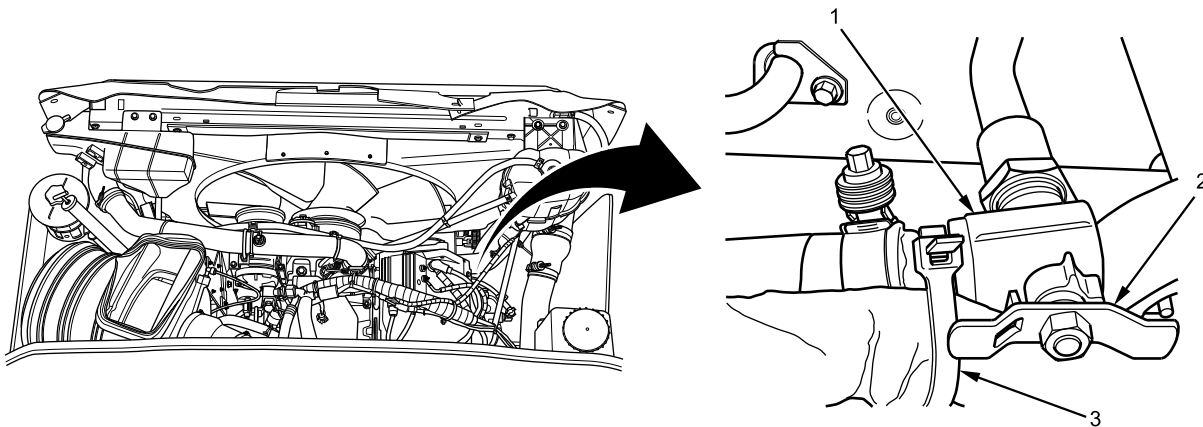

B235203109

Figure 10. Heater Coolant Engine Outlet Valve.

15. Open outlet valve (Figure 10, Item 1) by turning handle (Figure 10, Item 2) counterclockwise. Install new cable lock strap (Figure 10, Item 3) if removed.
16. Check radiator coolant level.

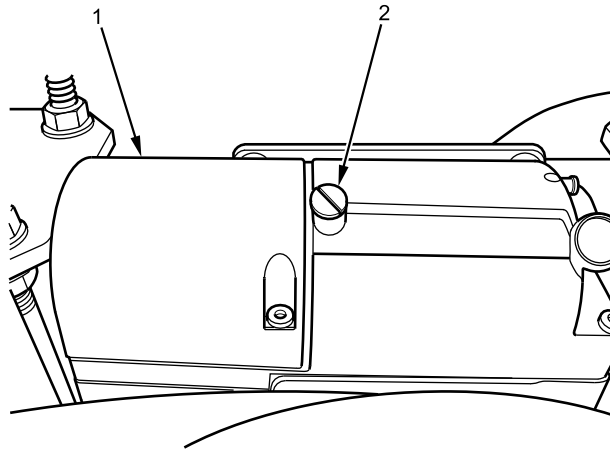
FUEL-FIRED HEATER REMOVAL AND INSTALLATION - (CONTINUED)

B230312339

Figure 11. Fuel-Fired Heater Bleed Screw.

17. Bleed air from heater (Figure 11, Item 1) by opening bleed screw (Figure 11, Item 2) on top of heater. Close bleed screw after a solid stream of coolant is visible at heater.
18. Install all cable lock straps and tighten securely.
19. Remove drain pan.

END OF TASK**FOLLOW-ON MAINTENANCE**

1. Install right A/C condenser panel (WP 0672).
2. Turn MAIN POWER switch on (TM 9-2355-106-10).
3. Turn engine on (TM 9-2355-106-10).
4. Verify fuel-fired heater operation (TM 9-2355-106-10).
5. Check for leaks with engine running (TM 9-2355-106-10).
6. Turn engine off (TM 9-2355-106-10).
7. Turn MAIN POWER switch off (TM 9-2355-106-10).
8. Close and secure engine hood (TM 9-2355-106-10).
9. Remove wheel chocks (TM 9-2355-106-10).

END OF TASK**END OF WORK PACKAGE**

FIELD MAINTENANCE
FUEL-FIRED HEATER FUEL PUMP AND FUEL LINE REMOVAL AND INSTALLATION

INITIAL SETUP:**Tools and Special Tools**

General Mechanic's Tool Kit (GMTK)
(WP 0795, Item 37)
Drain pan (WP 0795, Item 75)

TM 9-2355-106-23P

WP 0786

WP 0782

Materials/Parts

Gloves (WP 0794, Item 18)
Goggles, industrial (WP 0794, Item 20)
Faceshield, industrial (WP 0794, Item 16)
Compound (WP 0794, Item 13)
Cable lock strap - (9) (WP 0796, Item 120)

Equipment Condition

Parking brake set (TM 9-2355-106-10)
Transmission set in NEUTRAL (N) (TM
9-2355-106-10)
Engine off (TM 9-2355-106-10)
MAIN POWER switch off (TM 9-2355-106-10)
Wheels chocked (TM 9-2355-106-10)
Belly armor removed (WP 0606)

References

TM 9-2355-106-10

WARNING

Fuel is flammable and can explode. Keep all open flames, flammable materials, ignition sources, and sparks away from diesel fuel and keep fire extinguisher nearby. Do not smoke when working with fuel. Do not work on fuel system when engine is hot. Fuel can be ignited by hot engine. Failure to comply may result in serious injury or death to personnel.

Be alert at all times for the smell of fuel. Hot engines and components can ignite fuel. If fuel smell is detected while operating vehicle, shut down vehicle immediately. Failure to comply may result in damage to equipment and serious injury or death to personnel.

Store diesel fuel in an approved container clearly marked DIESEL FUEL or JP-8, accordingly. Dispose of fuel in an approved container clearly marked DIESEL FUEL or JP-8, accordingly, in accordance with standard operating procedures.

Never use diesel fuel or JP-8 to clean parts. Fuel is highly flammable. Failure to comply may result in damage to equipment and serious injury or death to personnel.

FUEL-FIRED HEATER FUEL PUMP AND FUEL LINE REMOVAL AND INSTALLATION - (CONTINUED)

Use extreme caution when testing or working on or around electrical circuits. Always assume that electrical circuits are live. Electrical shock can occur upon contact with voltage high enough to cause current flow through muscles or nerves. On Direct Current (DC) systems, generally 1 milliamp of current can be felt, 5 milliamps can cause severe pain, 15 milliamps can cause loss of muscle control, and 70 milliamps can be fatal. Wear protective clothing; ensure skin, clothing, and surrounding areas are dry; do not wear jewelry; and touch only the insulated, nonmetallic parts of electrical components and testing equipment. To prevent electrical arcing, avoid shorting electrical test probes and jumper wires. Electrical arcing can cause bright flashes of light, capable of causing temporary blindness. If electrical injury occurs, immediately shut off power supply and seek medical assistance. Failure to comply may result in serious injury or death to personnel.

NOTE

Remove cable lock straps as necessary to perform procedure. Note position and size of cable lock straps to aid installation.

FUEL-FIRED HEATER FUEL PUMP AND FUEL LINE REMOVAL AND INSTALLATION - (CONTINUED)

REMOVAL

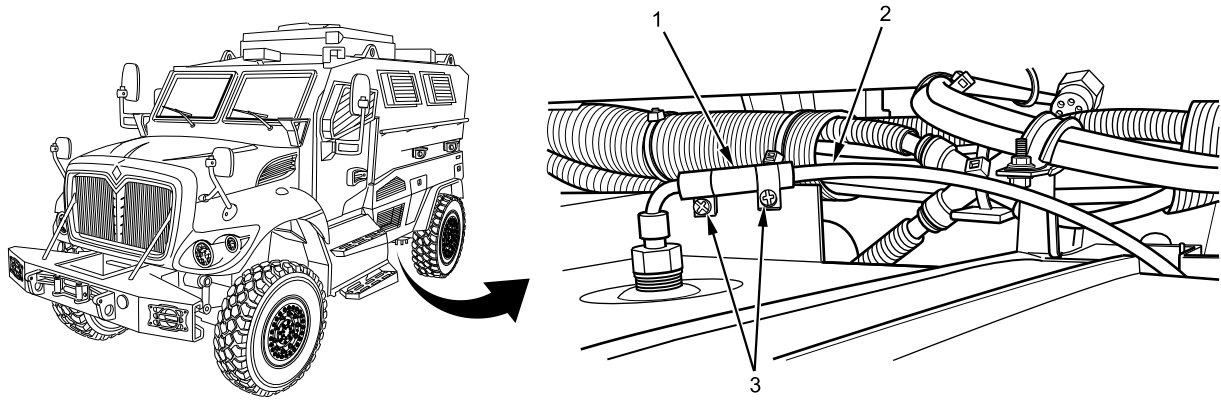

B230305215

Figure 1. Fuel Tank Connection.

1. Loosen fuel hose clamps (Figure 1, Item 3). Remove fuel line hose (Figure 1, Item 1) and fuel hose clamps (Figure 1, Item 3).
2. Drain fuel from fuel line tubing (Figure 1, Item 2) into drain pan.

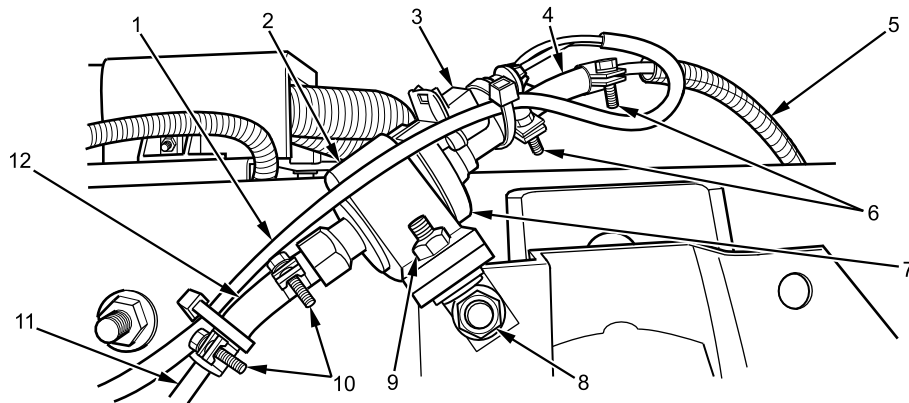

B230312044

Figure 2. Fuel-Fired Heater Fuel Pump.

FUEL-FIRED HEATER FUEL PUMP AND FUEL LINE REMOVAL AND INSTALLATION - (CONTINUED)

3. Disconnect harness connector (Figure 2, Item 3) on fuel-fired heater fuel pump electrical harness (Figure 2, Item 1).
4. Loosen fuel hose clamps (Figure 2, Item 6). Remove fuel line hose (Figure 2, Item 4) and fuel hose clamps (Figure 2, Item 6).
5. Drain fuel from fuel line tubing (Figure 2, Item 5) into drain pan.
6. Loosen fuel hose clamps (Figure 2, Item 10). Remove fuel line hose (Figure 2, Item 12) and fuel hose clamps (Figure 2, Item 10).
7. Drain fuel from fuel line tubing (Figure 2, Item 11) into drain pan.
8. Remove fuel pump bracket extension nut (Figure 2, Item 8) and fuel-fired heater fuel pump bracket (Figure 2, Item 2).
9. Remove fuel-fired heater fuel pump bracket nut (Figure 2, Item 9).
10. Remove fuel-fired heater fuel pump (Figure 2, Item 7) from fuel-fired heater fuel pump bracket (Figure 2, Item 2).
11. Loosen fuel line hose clamps (Figure 3, Item 3). Remove fuel line hose (Figure 3, Item 1) and fuel hose clamps (Figure 3, Item 3) from inlet for fuel-fired heater (Figure 3, Item 4).

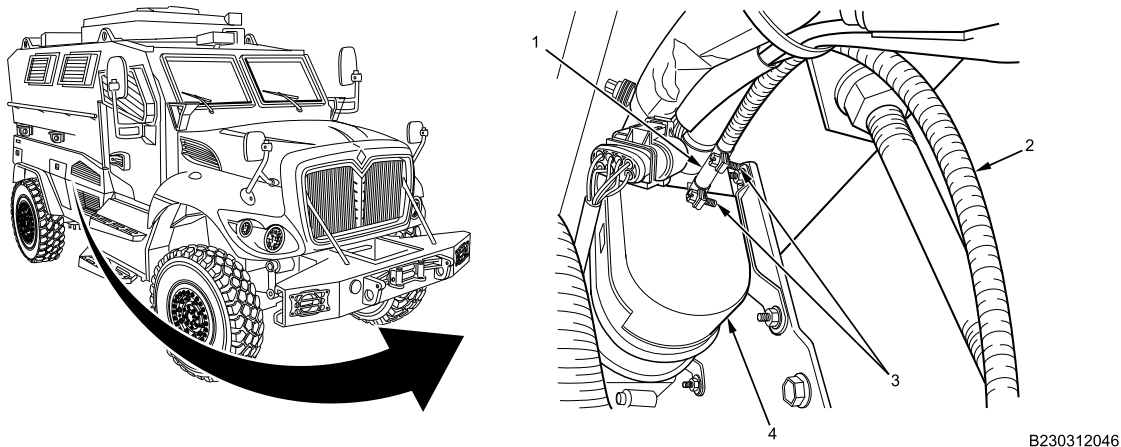

Figure 3. Fuel-Fired Heater Fuel Line Connection.

12. Drain fuel from fuel line tubing (Figure 3, Item 2) into drain pan.

NOTE

Note routing of fuel line tubing to aid installation.

13. Remove fuel line tubing from vehicle (Figure 3, Item 2).
14. Remove drain pan.

END OF TASK

FUEL-FIRED HEATER FUEL PUMP AND FUEL LINE REMOVAL AND INSTALLATION - (CONTINUED)**INSTALLATION****WARNING**

Corrosion preventive compound is toxic. Use only in well-ventilated area. Do not get in eyes; wear chemical safety goggles and full-face shield when using. Avoid contact with skin and wear rubber or plastic, solvent-resistant gloves. In case of contact, remove contaminated clothing and immediately wash area with soap and water. If compound contacts eyes, flush eyes with large amounts of water for at least 15 minutes and get immediate medical attention. If swallowed, do not induce vomiting; contact a physician immediately. Failure to comply may result in serious injury or death to personnel.

NOTE

Apply corrosion preventive compound to all fuel hose clamp threads and fuel-fired heater fuel pump bracket bolts.

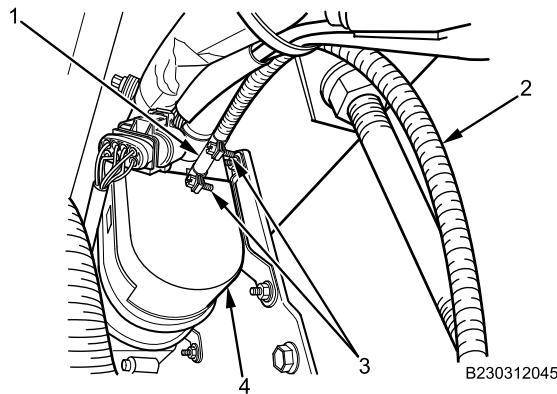
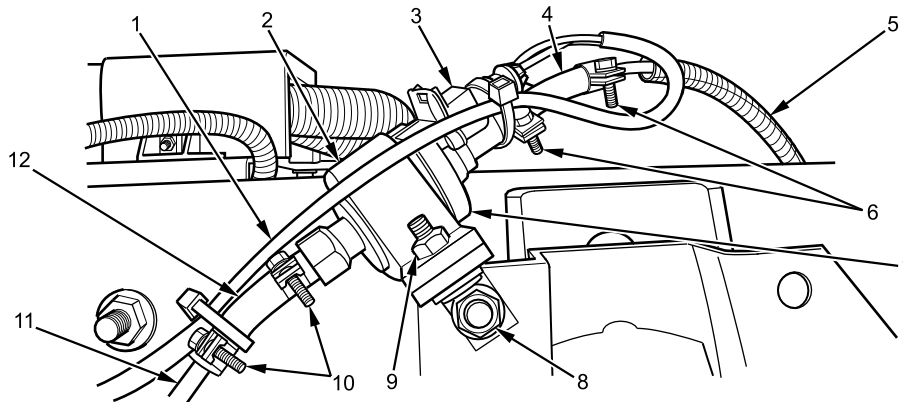

Figure 4. Fuel-Fired Heater Fuel Line Connection.

1. Position fuel line hose (Figure 4, Item 1) and fuel hose clamps (Figure 4, Item 3) on fuel line tubing (Figure 4, Item 2) and inlet for fuel-fired heater (Figure 4, Item 4). Tighten clamps securely.
2. Route fuel line tubing (Figure 4, Item 2).

FUEL-FIRED HEATER FUEL PUMP AND FUEL LINE REMOVAL AND INSTALLATION - (CONTINUED)



B230312044

Figure 5. Fuel-Fired Heater Fuel Pump.

3. Install fuel-fired heater fuel pump bracket extension with nut (Figure 5, Item 8).
4. Install fuel-fired heater fuel pump (Figure 5, Item 7) on fuel-fired heater fuel pump bracket (Figure 5, Item 2).
5. Install fuel-fired heater fuel pump bracket (Figure 5, Item 2) with nut (Figure 5, Item 8). Tighten bracket and bracket extension nuts securely.
6. Position fuel line hose (Figure 5, Item 12) and fuel hose clamps (Figure 5, Item 10) on fuel line tubing (Figure 5, Item 11) and inlet for fuel pump (Figure 5, Item 7). Tighten clamps securely.
7. Position fuel line hose (Figure 5, Item 4) and fuel hose clamps (Figure 5, Item 6) on fuel line tubing (Figure 5, Item 5) and outlet for fuel pump (Figure 5, Item 7). Tighten clamps securely.

WARNING

Dielectric grease is harmful to skin and eyes. If grease contacts eyes, rinse thoroughly and contact physician if irritation persists. If skin is contacted, wash thoroughly with soap and water. Failure to comply may result in serious injury to personnel.

8. Apply dielectric grease to fuel-fired heater fuel pump electrical harness connector (Figure 5, Item 3).
9. Connect harness connector (Figure 5, Item 3) to fuel-fired heater fuel pump electrical harness (Figure 5, Item 1).

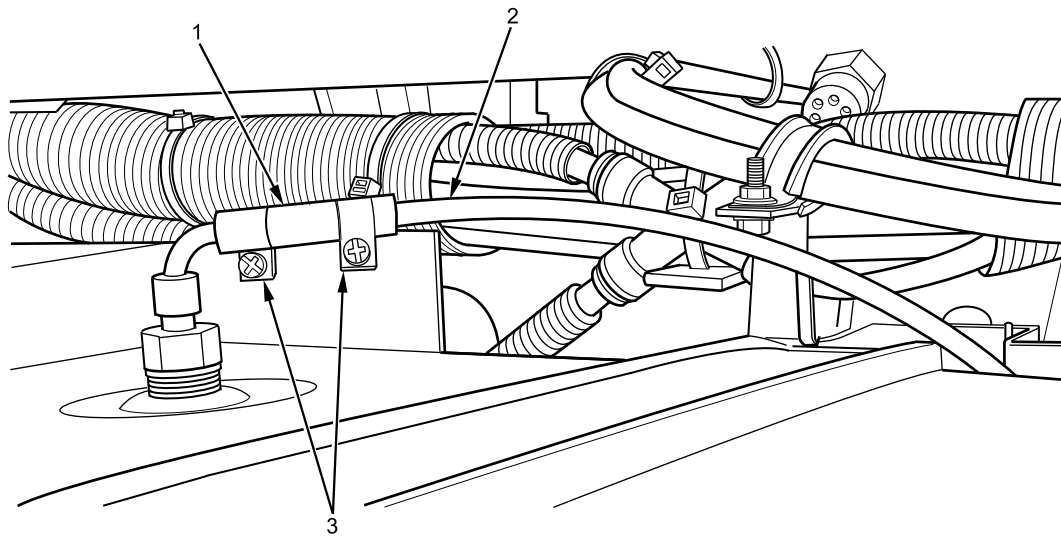
FUEL-FIRED HEATER FUEL PUMP AND FUEL LINE REMOVAL AND INSTALLATION - (CONTINUED)

B230302470

Figure 6. Fuel Tank Connection.

10. Position fuel line hose (Figure 6, Item 1) and fuel hose clamps (Figure 6, Item 3) on fuel line tubing (Figure 6, Item 2) and fuel tank outlet. Tighten clamps securely.
11. Install new cable lock straps.

END OF TASK**FOLLOW-ON MAINTENANCE**

1. Turn MAIN POWER switch on (TM 9-2355-106-10).
2. Verify fuel-fired heater operation (TM 9-2355-106-10) and inspect for leaks.
3. Turn engine off (TM 9-2355-106-10).
4. Turn MAIN POWER switch off (TM 9-2355-106-10).
5. Install belly armor (WP 0606).
6. Remove wheel chocks (TM 9-2355-106-10).

END OF TASK**END OF WORK PACKAGE**

FIELD MAINTENANCE

FUEL FIRED HEATER AND FUEL FIRED HEATER FUEL PUMP HARNESS REMOVAL AND INSTALLATION

INITIAL SETUP:

Tools and Special Tools

General Mechanic's Tool Kit (GMTK)
(WP 0795, Item 37)

TM 9-2355-106-23P

WP 0786

WP 0782

Materials/Parts

Grease (WP 0794, Item 22)
Cable lock strap - (5) (WP 0796, Item 124)
Cable lock strap - (12) (WP 0796, Item 134)

Equipment Condition

Parking brake set (TM 9-2355-106-10)
Transmission set in NEUTRAL (N) (TM 9-2355-106-10)
Engine off (TM 9-2355-106-10)
MAIN POWER switch off (TM 9-2355-106-10)
Wheels chocked (TM 9-2355-106-10)
Engine hood open and secured (TM 9-2355-106-10)
Belly armor removed (WP 0606)

Personnel Required

Maintainer - (2)

References

TM 9-2355-106-10

WARNING



Engine hood is extremely heavy and requires two-person lift. Ensure that there is adequate space in front of the vehicle to open hood completely without pinning or pinching personnel between hood and any other structure. Use extreme care when working under hood and make sure it is properly supported. Failure to comply may result in serious injury or death to personnel.

Use extreme caution when testing or working on or around electrical circuits. Always assume that electrical circuits are live. Electrical shock can occur upon contact with voltage high enough to cause current flow through muscles or nerves. On Direct Current (DC) systems, generally 1 milliamp of current can be felt, 5 milliamps can cause severe pain, 15 milliamps can cause loss of muscle control, and 70 milliamps can be fatal. Wear protective clothing; ensure skin, clothing, and surrounding areas are dry; do not wear jewelry; and touch only the insulated, nonmetallic parts of electrical components and testing equipment. To prevent electrical arcing, avoid shorting electrical test probes and jumper wires. Electrical arcing can cause bright flashes of light, capable of causing temporary blindness. If electrical injury occurs, immediately shut off power supply and seek medical assistance. Failure to comply may result in serious injury or death to personnel.

FUEL FIRED HEATER AND FUEL FIRED HEATER FUEL PUMP HARNESS REMOVAL AND INSTALLATION - (CONTINUED)

REMOVAL

NOTE

Fuel fired heater is located on outside of right frame rail in front of right rear wheel.

Note location of cable lock straps prior to removal to aid in installation.

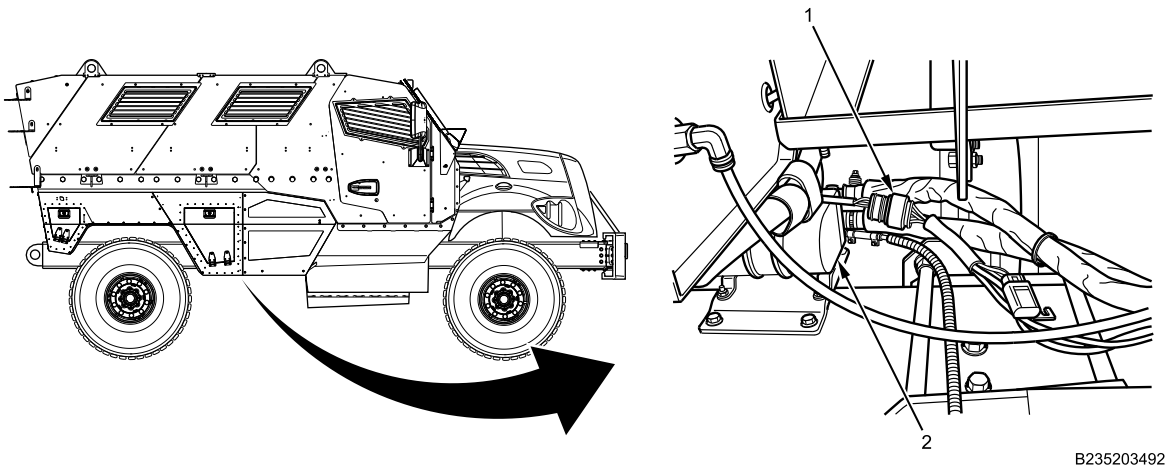

B235203492

Figure 1. Fuel Fired Heater Connector.

1. Disconnect electrical connector (Figure 1, Item 1) from fuel fired heater (Figure 1, Item 2).

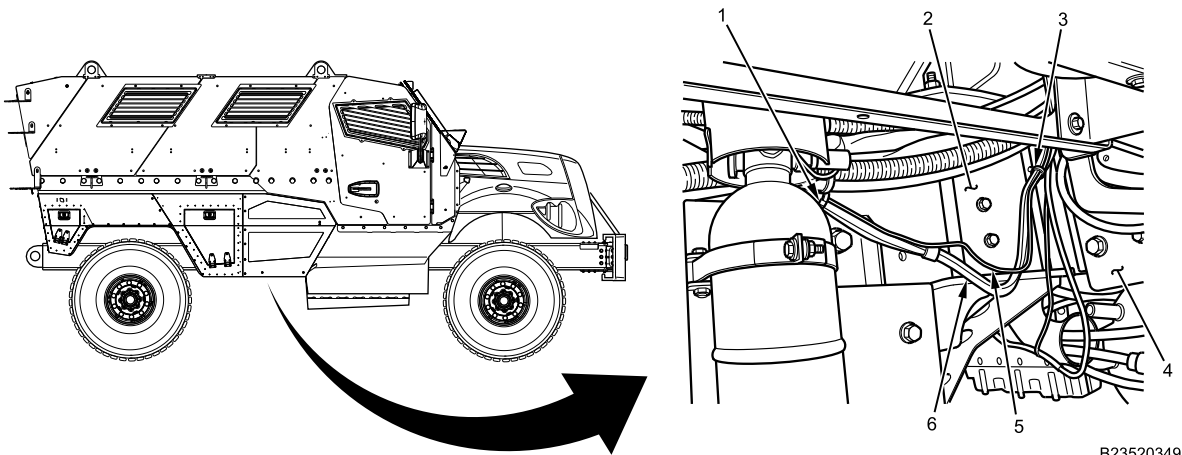

B235203493

Figure 2. Fire Suppression System (FSS) Harness.

2. On outside of right frame rail (Figure 2, Item 2) directly behind battery box (Figure 2, Item 4), remove and discard two cable lock straps (Figure 2, Item 1 and 3) to separate fuel fired heater harness (Figure 2, Item 6) from fire suppression system (FSS) harness (Figure 2, Item 5).

FUEL FIRED HEATER AND FUEL FIRED HEATER FUEL PUMP HARNESS REMOVAL AND INSTALLATION - (CONTINUED)

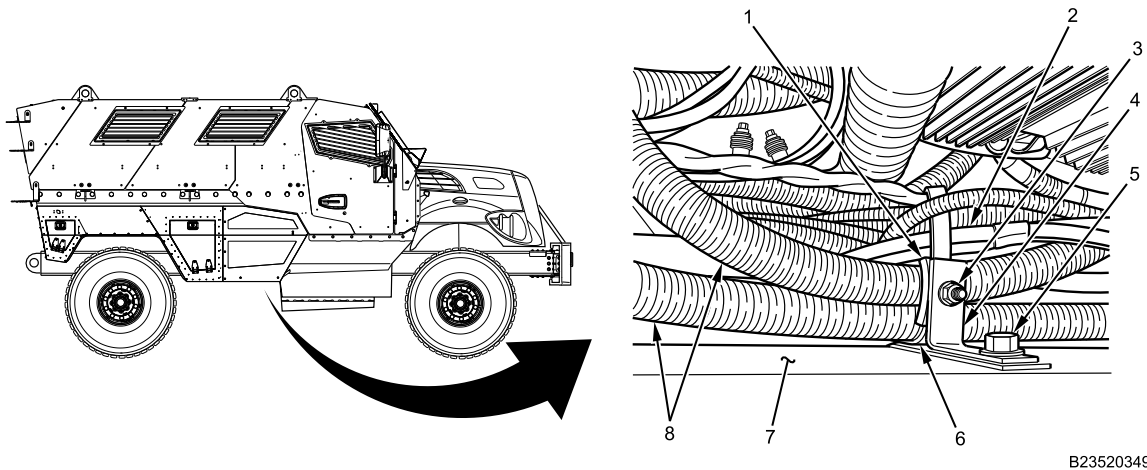

B235203494

Figure 3. Frame Bracket.

3. Between battery box and outside of right frame rail (Figure 3, Item 7), remove and discard cable lock strap (Figure 3, Item 6) from saddle clamp (Figure 3, Item 1) bolted to bracket (Figure 3, Item 4) on frame.
4. Remove nut (Figure 3, Item 3) and saddle clamp (Figure 3, Item 1) from bracket (Figure 3, Item 4).
5. Remove nut, bolt (Figure 3, Item 5) from bracket on frame rail (Figure 3, Item 7).
6. Separate fuel fired heater harness (Figure 3, Item 2) from main harnesses (Figure 3, Item 8).

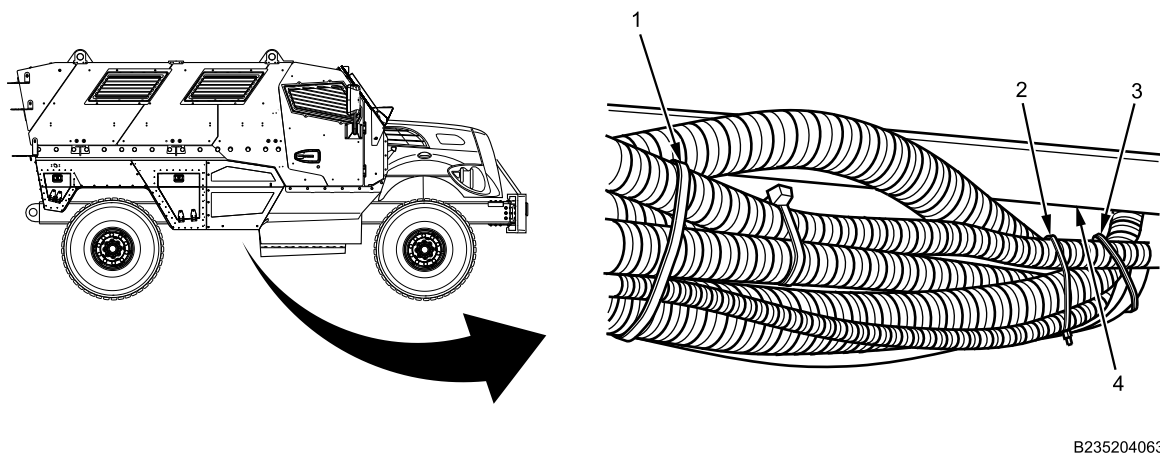

B235204063

Figure 4. Main Harness, Right Side.

7. Inboard of right frame rail (Figure 4, Item 4) next to transmission bellhousing, remove and discard three cable lock straps (Figure 4, Item 1, 2 and 3).

FUEL FIRED HEATER AND FUEL FIRED HEATER FUEL PUMP HARNESS REMOVAL AND INSTALLATION - (CONTINUED)

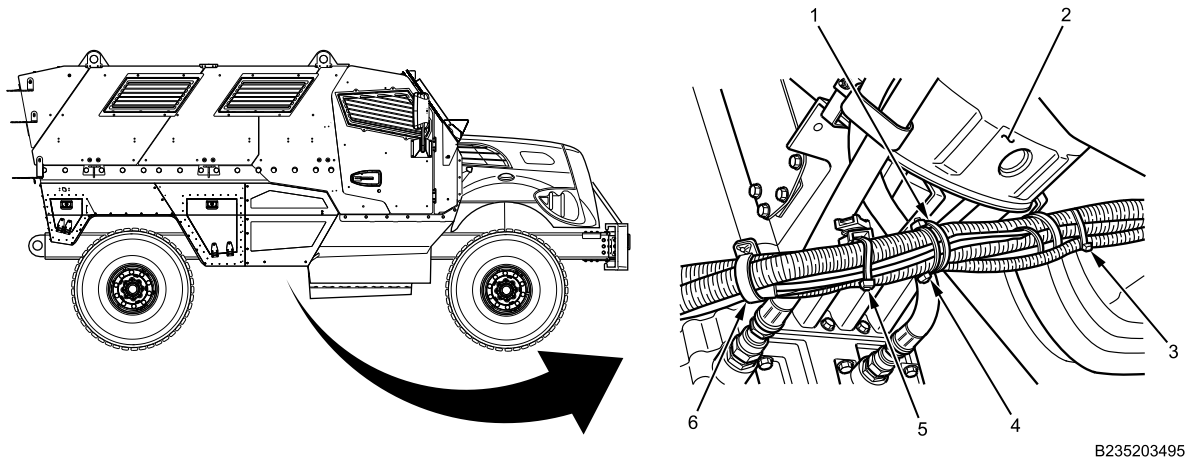

B235203495

Figure 5. Transmission Bellhousing.

8. Under transmission bellhousing (Figure 5, Item 2), remove and discard five cable lock straps (Figure 5, Item 1, 3, 4, 5 and 6) from main harness assembly.

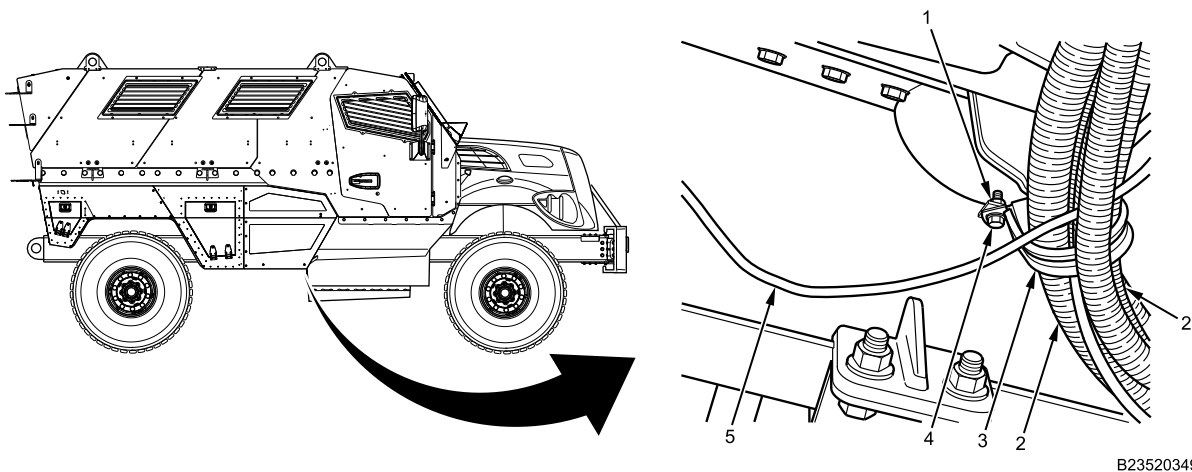

B235203496

Figure 6. Fuel Fired Heater Harness.

9. Remove nut (Figure 6, Item 1), bolt (Figure 6, Item 4), and harness loop (Figure 6, Item 3).
 10. Separate fuel fired heater harness (Figure 6, Item 5) from main harness assembly (Figure 6, Item 2).

FUEL FIRED HEATER AND FUEL FIRED HEATER FUEL PUMP HARNESS REMOVAL AND INSTALLATION - (CONTINUED)

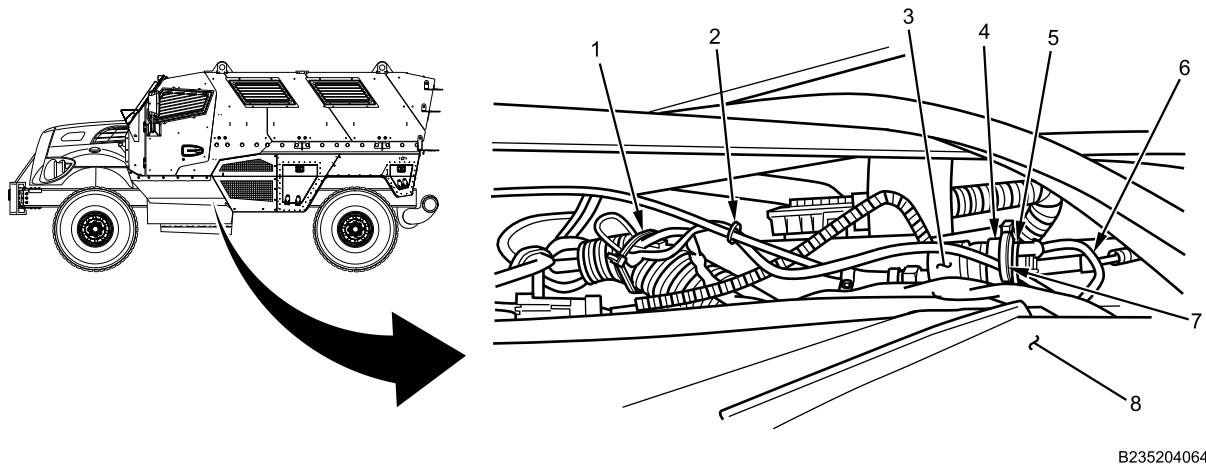

B235204064

Figure 7. Fuel Pump Connector.

11. At rear of fuel tank (Figure 7, Item 8), remove and discard three cable lock straps (Figure 7, Item 1, 2 and 7) from fuel fired heater fuel pump (Figure 7, Item 3).
12. Press down on wire locking device (Figure 7, Item 4) and disconnect fuel fired heater fuel pump connector (Figure 7, Item 5).
13. From under vehicle, pull fuel fired heater fuel pump connector (Figure 7, Item 5) and harness (Figure 7, Item 6) to bellhousing area.

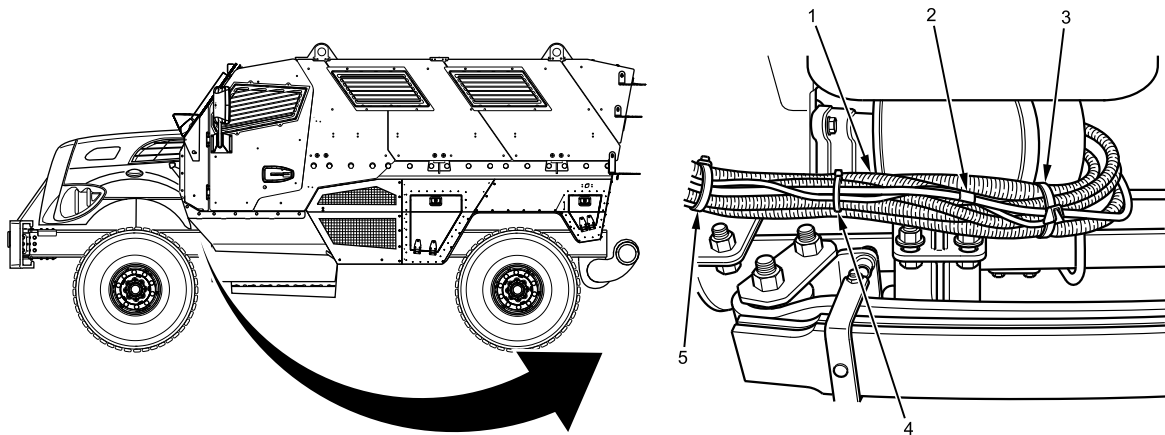

B235203498

Figure 8. Main Harness Near Starter.

14. Following main harness assembly (Figure 8, Item 1) forward from transmission bellhousing, remove and discard three cable lock straps (Figure 8, Item 3, 4 and 5) from main harness assembly
15. Separate fuel fired heater harness (Figure 8, Item 2) from main harness assembly (Figure 8, Item 1).

FUEL FIRED HEATER AND FUEL FIRED HEATER FUEL PUMP HARNESS REMOVAL AND INSTALLATION - (CONTINUED)

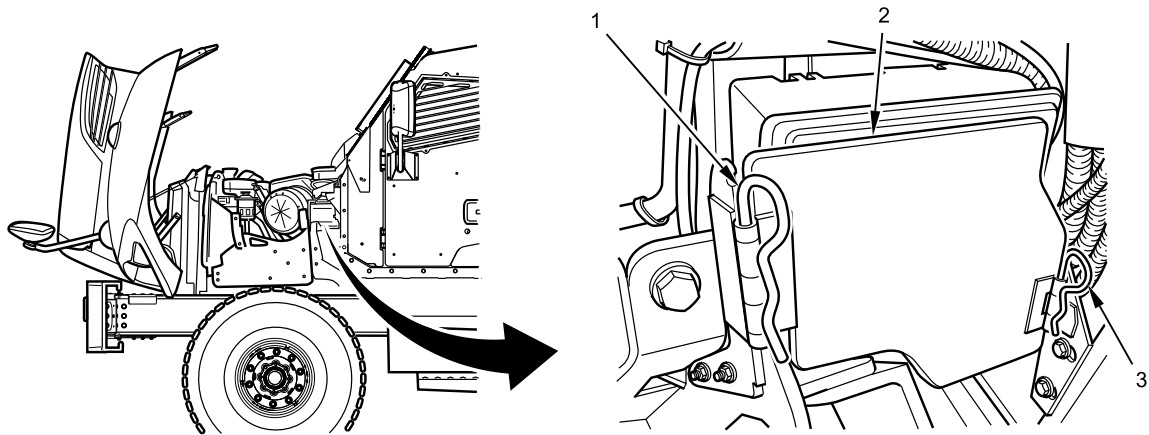

B230601937

Figure 9. Power Distribution Center (PDC) Armor.

16. Remove power distribution center (PDC) armor clips (Figure 9, Item 1 and 3) and PDC armor (Figure 9, Item 2).

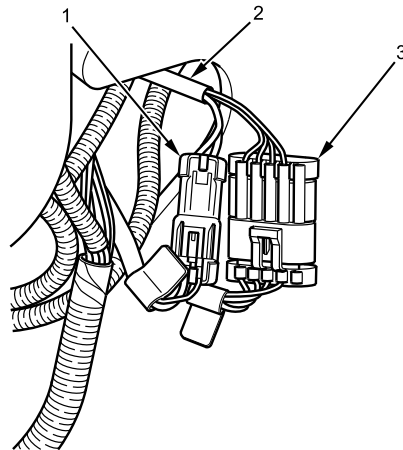

B235203499

Figure 10. Fuel Fired Heater and Fuel Fired Heater Fuel Pump Harness Connectors at PDC.

17. Below PDC, disconnect fuel fired heater connector (Figure 10, Item 1) and fuel fired heater fuel pump connector (Figure 10, Item 3) from harness (Figure 10, Item 2).
18. From under vehicle, remove fuel fired heater harness from vehicle.

END OF TASK

FUEL FIRED HEATER AND FUEL FIRED HEATER FUEL PUMP HARNESS REMOVAL AND INSTALLATION - (CONTINUED)**INSTALLATION****WARNING**

Dielectric grease is harmful to skin and eyes. If grease contacts eyes, rinse thoroughly and contact physician if irritation persists. If skin is contacted, wash thoroughly with soap and water. Failure to comply may result in serious injury to personnel.

NOTE

Apply dielectric grease to all electrical connections.

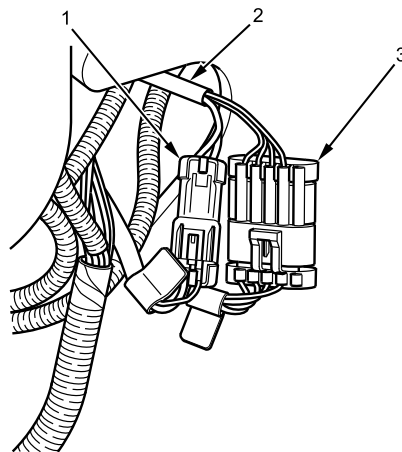

B235203499

Figure 11. Fuel Fired Heater and Fuel Fired Heater Fuel Pump Harness Connectors at PDC.

1. From under vehicle, push fuel fired heater harness connectors up toward PDC. With maintainer assistance positioned above vehicle, pull connectors up toward PDC.

FUEL FIRED HEATER AND FUEL FIRED HEATER FUEL PUMP HARNESS REMOVAL AND INSTALLATION - (CONTINUED)

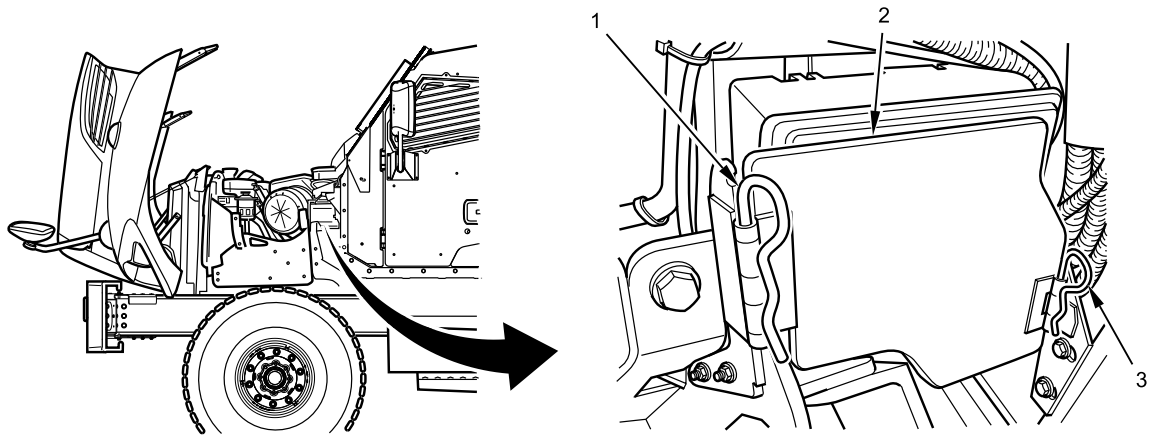

B230601937

Figure 12. PDC Armor Plate.

2. Below PDC, connect fuel fired heater (Figure 11, Item 1) and fuel fired heater fuel pump (Figure 11, Item 3) on harness (Figure 11, Item 2).

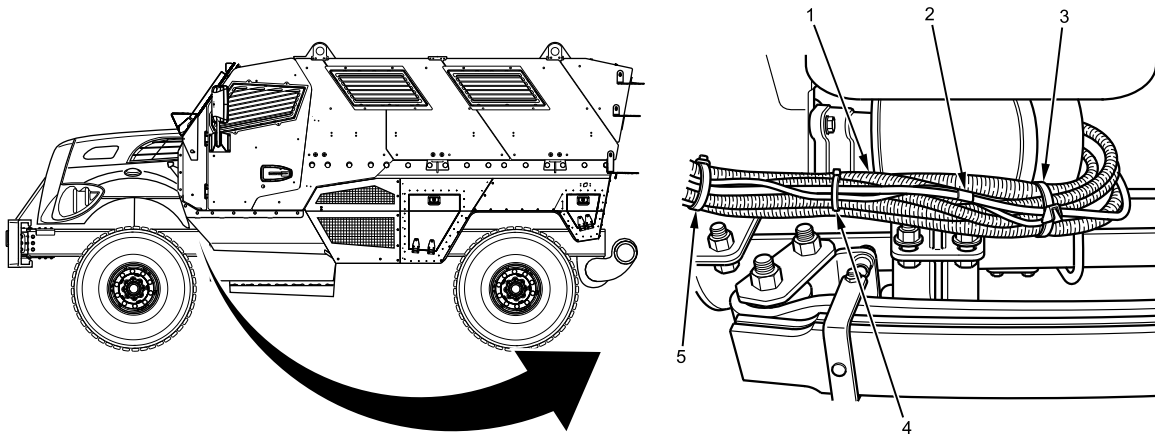

B235203498

Figure 13. Main Harness Near Starter.

3. Install PDC armor plate (Figure 12, Item 2) and clips (Figure 12, Item 1 and 3).
4. Following main harness assembly (Figure 13, Item 1) forward from transmission bellhousing, install three new cable lock straps (Figure 13, Item 3, 4 and 5) fastening main harness assembly, fuel fired heater, and fuel fired heater harness (Figure 13, Item 2) together.

FUEL FIRED HEATER AND FUEL FIRED HEATER FUEL PUMP HARNESS REMOVAL AND INSTALLATION - (CONTINUED)

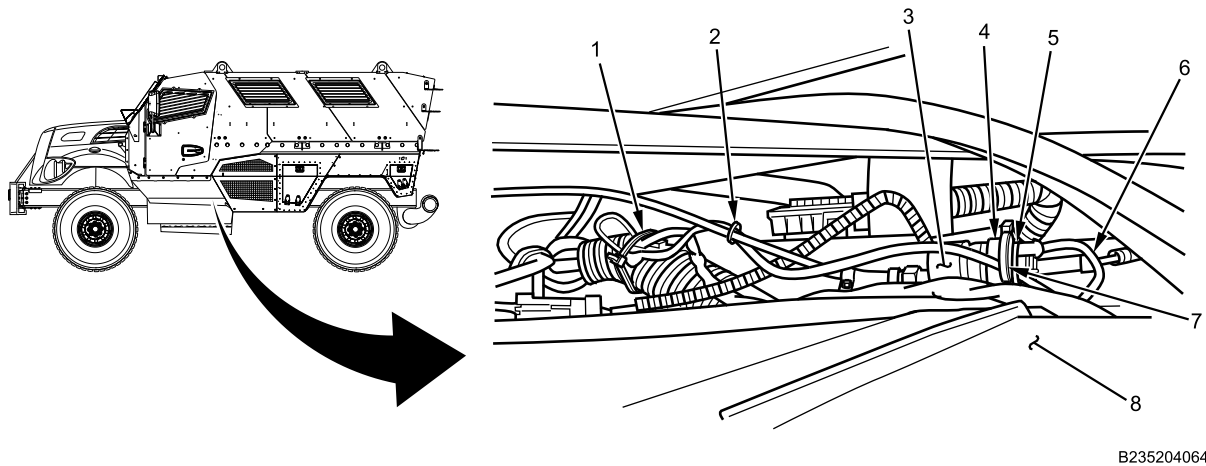

B235204064

Figure 14. Fuel Pump Connector.

5. From under vehicle, and with maintainer assistance positioned above vehicle, push fuel fired heater fuel pump connector over top of left frame rail and route it to fuel fired heater fuel pump area.
6. Connect fuel fired heater fuel pump connector (Figure 14, Item 5), making sure wire locking device (Figure 14, Item 4) pops up and locks connector in place. Pull backward on connector to make sure it is properly locked.
7. At rear of fuel tank area (Figure 14, Item 8), install three new cable lock straps (Figure 14, Item 1, 2 and 7) fastening fuel fired heater harness (Figure 14, Item 6) to fuel fired heater fuel pump (Figure 14, Item 3).

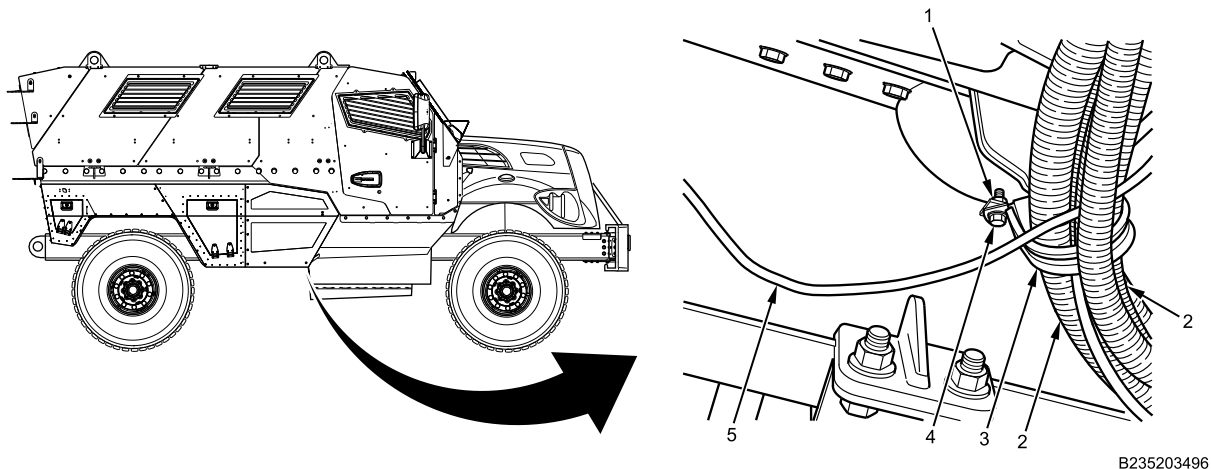

B235203496

Figure 15. Fuel Fired Heater Harness.

NOTE

Note fuel fired heater fuel pump connector and harness exits the main harness assembly between two brackets bolted to bottom of transmission bellhousing.

8. Position main harness assembly (Figure 15, Item 2) along with fuel fired heater harness (Figure 15, Item 5) in harness loop (Figure 15, Item 3), and install bolt (Figure 15, Item 4) and nut (Figure 15, Item 1) through harness loop and bracket. Tighten nut and bolt securely.

FUEL FIRED HEATER AND FUEL FIRED HEATER FUEL PUMP HARNESS REMOVAL AND INSTALLATION - (CONTINUED)

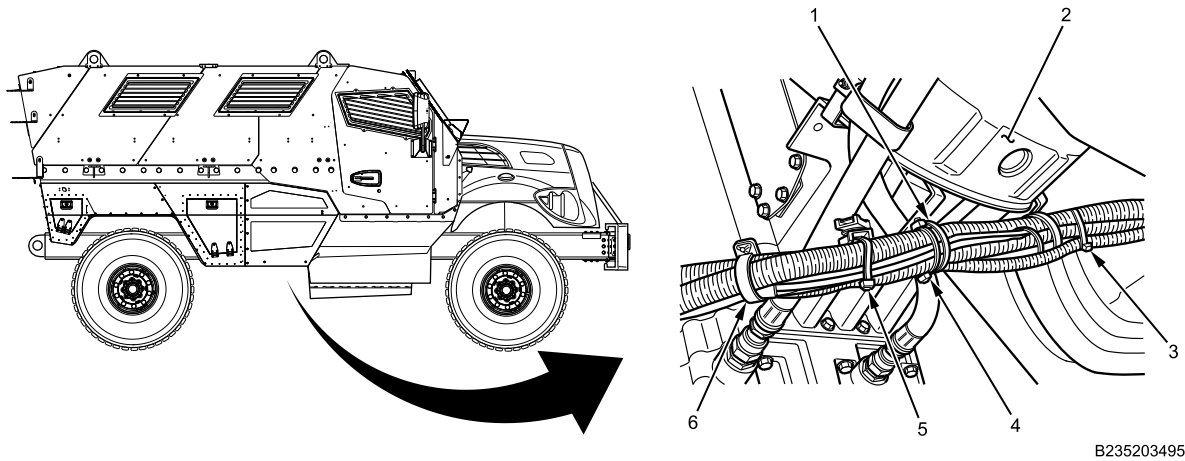

B235203495

Figure 16. Transmission Bellhousing.

9. From under transmission bellhousing (Figure 16, Item 2), install five new cable lock straps (Figure 16, Item 1, 3, 4, 5 and 6) fastening main harness assembly to fuel fired heater harness.
10. From under vehicle, push fuel fired heater harness under right frame rail, and with maintainer assistance, pull harness rearward between frame rail and battery box until it reaches fuel fired heater.

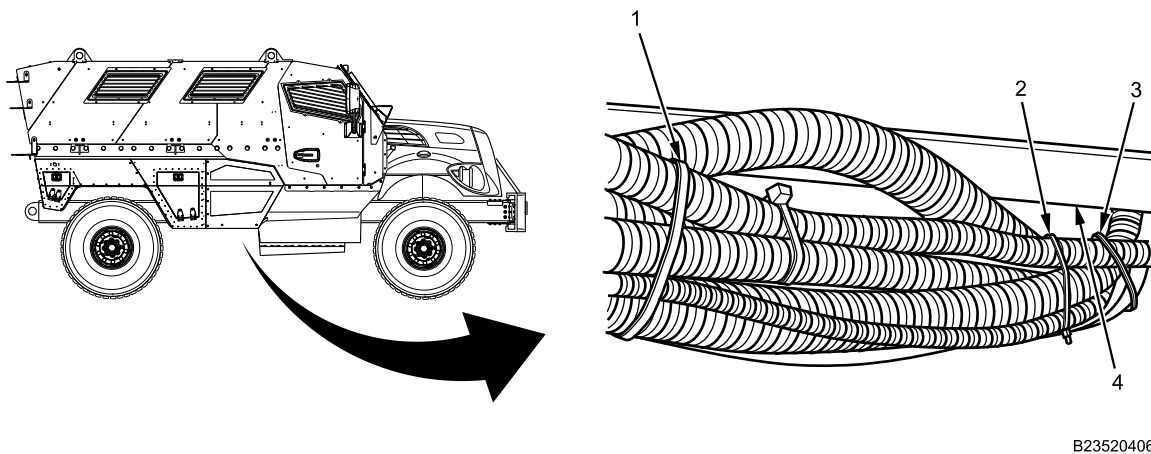

B235204063

Figure 17. Main Harness, Right Side.

11. Inboard of right frame rail (Figure 17, Item 4) next to transmission bellhousing, install three cable lock straps (Figure 17, Item 1, 2 and 3), fastening all harnesses together.

FUEL FIRED HEATER AND FUEL FIRED HEATER FUEL PUMP HARNESS REMOVAL AND INSTALLATION - (CONTINUED)

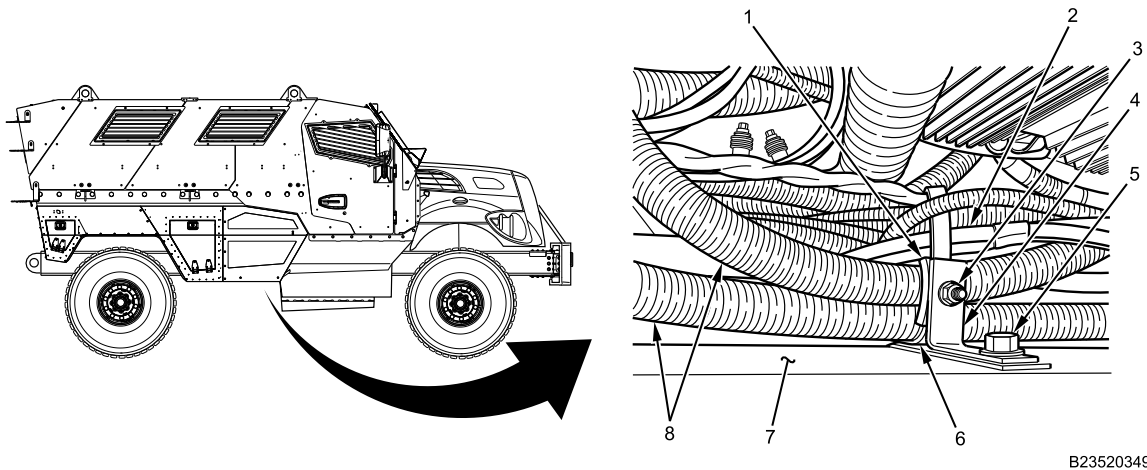

B235203494

Figure 18. Frame Bracket.

12. Install nut (Figure 18, Item 3) and saddle clamp (Figure 18, Item 1) onto bracket and install nut, bolt (Figure 18, Item 5) and bracket (Figure 18, Item 4) on frame rail. Tighten nuts securely.
13. Between battery box and outside of right frame rail (Figure 18, Item 7), install new cable lock strap (Figure 18, Item 6) around main harnesses (Figure 18, Item 8), fuel fired heater harness (Figure 18, Item 2), and through saddle clamp (Figure 18, Item 1) bolted to bracket (Figure 18, Item 4) on frame.

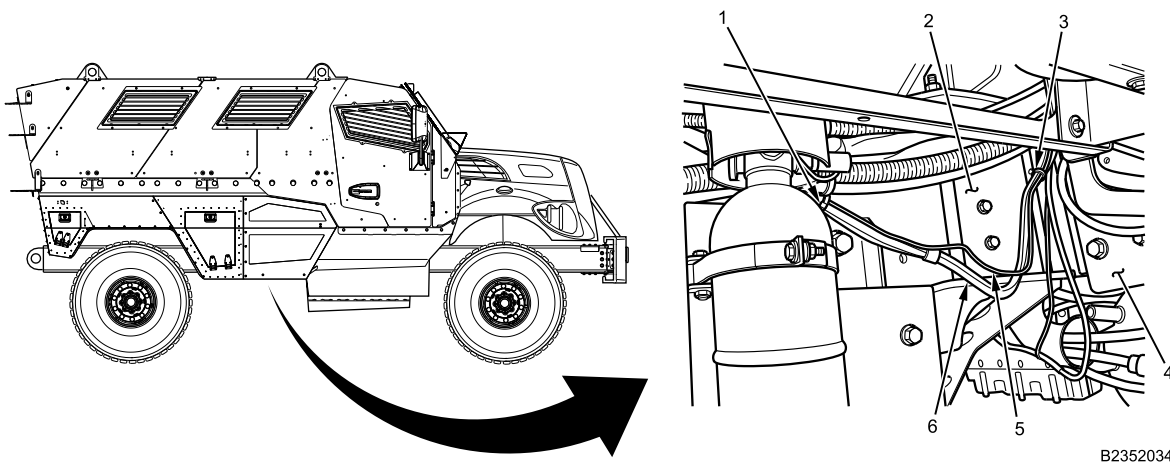

B235203493

Figure 19. FSS Harness.

14. On outside of right frame rail (Figure 19, Item 2) directly behind battery box (Figure 19, Item 4), install two new cable lock straps (Figure 19, Item 1 and 3) fastening fuel fired heater harness (Figure 19, Item 6) to FSS harness (Figure 19, Item 5).

FUEL FIRED HEATER AND FUEL FIRED HEATER FUEL PUMP HARNESS REMOVAL AND INSTALLATION - (CONTINUED)

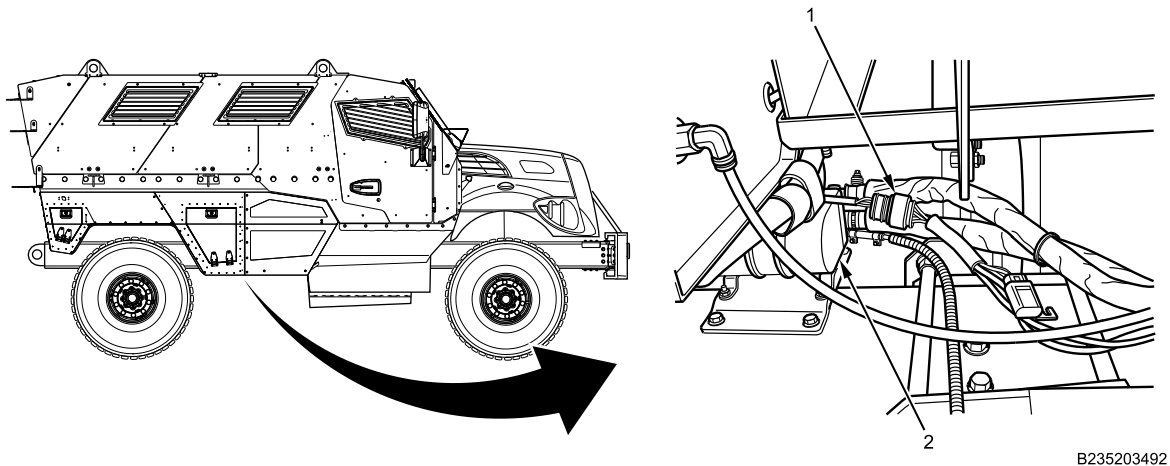

Figure 20. Fuel Fired Heater Connector.

NOTE

The microprocessor relay with the two-pin connector, located in the fuel fired heater harness, is not fastened to frame rail.

15. Connect eight-pin connector (Figure 20, Item 1) to fuel fired heater (Figure 20, Item 2).

END OF TASK

FOLLOW-ON MAINTENANCE

1. Close engine hood (TM-9-2355-106-10).
2. Turn MAIN POWER switch on (TM 9-2355-106-10).
3. Start engine (TM 9-2355-106-10).
4. Verify operation of fuel fired heater (TM 9-2355-106-10).
5. Turn engine off (TM 9-2355-106-10).
6. Turn MAIN POWER switch off (TM 9-2355-106-10).
7. Install belly armor (WP 0606).
8. Remove wheel chocks (TM 9-2355-106-10).

END OF TASK

END OF WORK PACKAGE

FIELD MAINTENANCE
FUEL-FIRED HEATER TIMER CONTROL REMOVAL AND INSTALLATION

INITIAL SETUP:**Tools and Special Tools**

General Mechanic's Tool Kit (GMTK)
(WP 0795, Item 37)

Materials/Parts

Grease (WP 0794, Item 22)

References

TM 9-2355-106-10
TM 9-2355-106-23P
WP 0786

WP 0782

Equipment Condition

Parking brake set (TM 9-2355-106-10)
Transmission set in NEUTRAL (N) (TM
9-2355-106-10)
Engine off (TM 9-2355-106-10)
MAIN POWER switch off (TM 9-2355-106-10)
Wheels chocked (TM 9-2355-106-10)
Instrument Panel (IP) storage bin removed
(WP 0563)

WARNING

Use extreme caution when testing or working on or around electrical circuits. Always assume that electrical circuits are live. Electrical shock can occur upon contact with voltage high enough to cause current flow through muscles or nerves. On Direct Current (DC) systems, generally 1 milliamp of current can be felt, 5 milliamps can cause severe pain, 15 milliamps can cause loss of muscle control, and 70 milliamps can be fatal. Wear protective clothing; ensure skin, clothing, and surrounding areas are dry; do not wear jewelry; and touch only the insulated, nonmetallic parts of electrical components and testing equipment. To prevent electrical arcing, avoid shorting electrical test probes and jumper wires. Electrical arcing can cause bright flashes of light, capable of causing temporary blindness. If electrical injury occurs, immediately shut off power supply and seek medical assistance. Failure to comply may result in serious injury or death to personnel.

NOTE

The fuel-fired heater timer system consists of a dash-mounted on/off switch and a timer.

FUEL-FIRED HEATER TIMER CONTROL REMOVAL AND INSTALLATION - (CONTINUED)

REMOVAL

1. Disconnect pigtail (Figure 1, Item 1) from fuel-fired heater timer switch (Figure 1, Item 4).

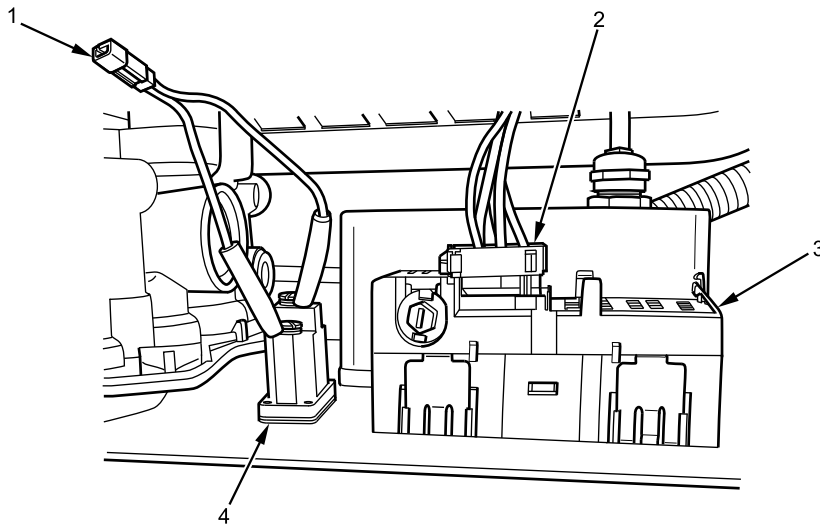

B230601245

Figure 1. Fuel-Fired Heater Timer Control Switch and Timer Wiring.

2. Disconnect connector (Figure 1, Item 2) from rear of fuel-fired heater timer control (Figure 1, Item 3).
3. Remove nut (Figure 2, Item 4), star washer (Figure 2, Item 3) and lock tab (Figure 2, Item 2) from fuel-fired heater timer control switch (Figure 2, Item 1).

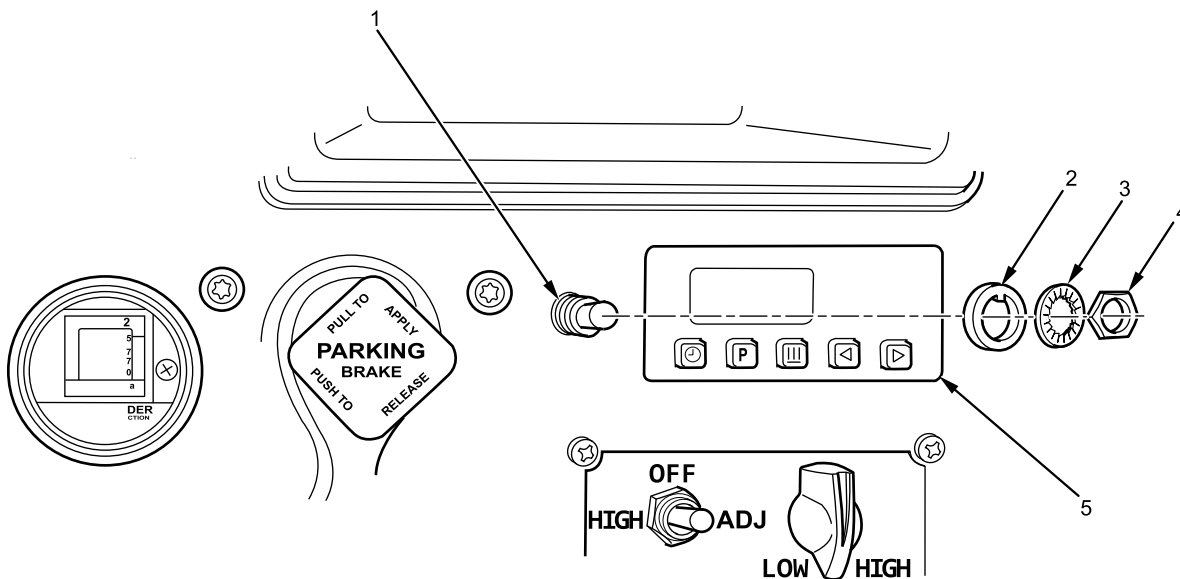

B230610221

Figure 2. Fuel-Fired Heater Timer Switch and Control.

4. Push fuel-fired heater timer control (Figure 2, Item 5) from back side to remove from IP trim center trim panel.

END OF TASK

FUEL-FIRED HEATER TIMER CONTROL REMOVAL AND INSTALLATION - (CONTINUED)

INSTALLATION

WARNING

Dielectric grease is harmful to skin and eyes. If lubricant contacts eyes, rinse thoroughly and contact physician if irritation persists. If skin is contacted, wash thoroughly with soap and water. Failure to comply may result in serious injury to personnel.

NOTE

Apply dielectric grease to all electrical connections.

1. Position fuel-fired heater timer control (Figure 3, Item 5) on IP center trim panel and push into IP center trim panel to secure.

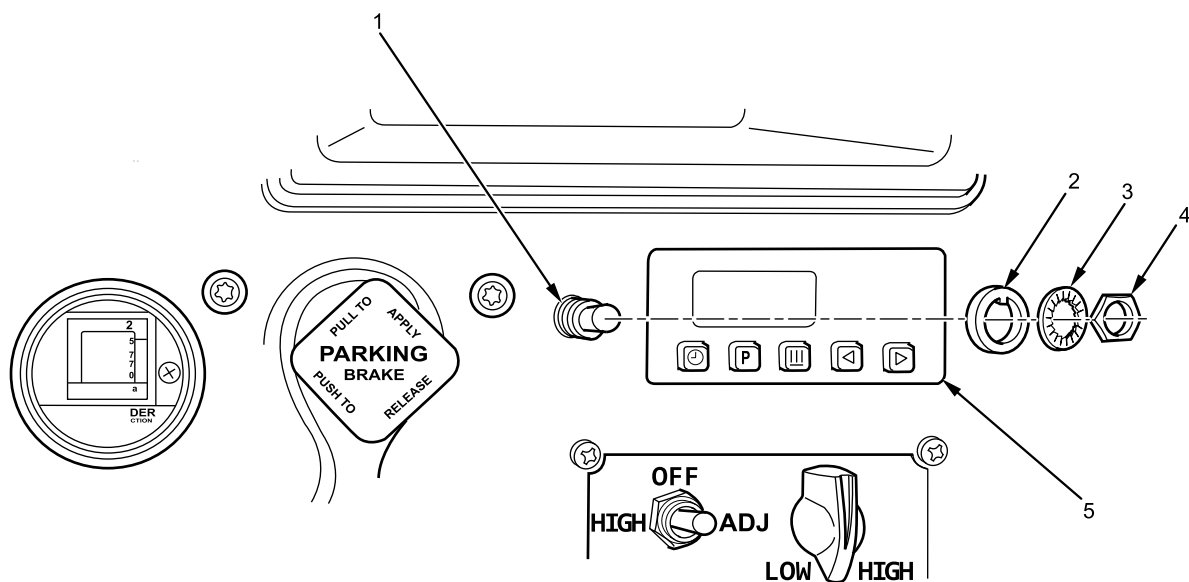

B230610221

Figure 3. Fuel-Fired Heater Timer Switch and Control.

2. Position fuel-fired heater timer control switch (Figure 3, Item 1) on IP center trim panel.
3. Install lock tab (Figure 3, Item 2), star washer (Figure 3, Item 3), and nut (Figure 3, Item 4) on control switch (Figure 3, Item 1). Tighten securely.
4. Connect fuel-fired heater timer control connector (Figure 4, Item 2) to rear of fuel-fired heater timer control (Figure 4, Item 3).

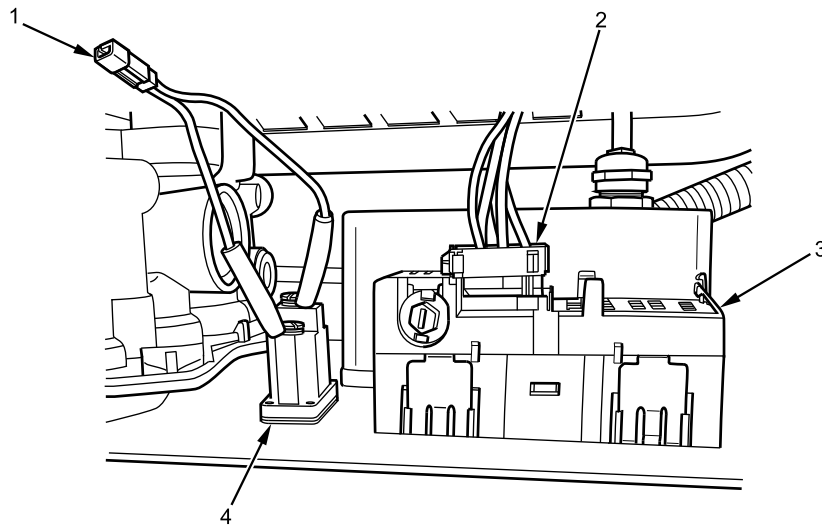
FUEL-FIRED HEATER TIMER CONTROL REMOVAL AND INSTALLATION - (CONTINUED)

B230601245

Figure 4. Fuel-Fired Heater Timer Control Switch and Timer Wiring.

5. Connect pigtail (Figure 4, Item 1) on fuel-fired heater timer control switch (Figure 4, Item 4).

END OF TASK**FOLLOW-ON MAINTENANCE**

1. Install IP storage bin (WP 0563).
2. Turn MAIN POWER switch on (TM 9-2355-106-10).
3. Verify fuel-fired heater timer control operation (TM 9-2355-106-10).
4. Turn engine off (TM 9-2355-106-10).
5. Turn MAIN POWER switch off (TM 9-2355-106-10).
6. Remove wheel chocks (TM 9-2355-106-10).

END OF TASK**END OF WORK PACKAGE**

FIELD MAINTENANCE**FIRE SUPPRESSION SYSTEM (FSS) DISABLE AND ENABLE**

INITIAL SETUP:**Tools and Special Tools**

General Mechanic's Tool Kit (GMTK)
(WP 0795, Item 37)

References

TM 9-2355-106-10
TM 9-2355-106-23P
WP 0782

Equipment Condition

Parking brake set (TM 9-2355-106-10)
Transmission set in NEUTRAL (N) (TM
9-2355-106-10)
Engine off (TM 9-2355-106-10)
MAIN POWER switch off (TM 9-2355-106-10)
Wheels chocked (TM 9-2355-106-10)

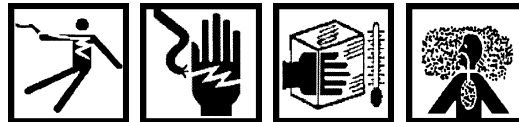
WARNING

Use extreme caution when testing or working on or around electrical circuits. Always assume that electrical circuits are live. Electrical shock can occur upon contact with voltage high enough to cause current flow through muscles or nerves. On Direct Current (DC) systems, generally 1 milliamp of current can be felt, 5 milliamps can cause severe pain, 15 milliamps can cause loss of muscle control, and 70 milliamps can be fatal. Wear protective clothing; ensure skin, clothing, and surrounding areas are dry; do not wear jewelry; and touch only the insulated, nonmetallic parts of electrical components and testing equipment. To prevent electrical arcing, avoid shorting electrical test probes and jumper wires. Electrical arcing can cause bright flashes of light, capable of causing temporary blindness. If electrical injury occurs, immediately shut off power supply and seek medical assistance. Failure to comply may result in serious injury or death to personnel.

Prior to servicing Fire Suppression System (FSS), make sure FSS power is off. Failure to comply may result in discharging of system and serious injury or death to personnel.

FIRE SUPPRESSION SYSTEM (FSS) DISABLE AND ENABLE - (CONTINUED)**REMOVAL**

1. Disconnect connector (Figure 1, Item 2) from FSS control box (Figure 1, Item 1) to disable FSS system. Position FSS harness (Figure 1, Item 3) aside.

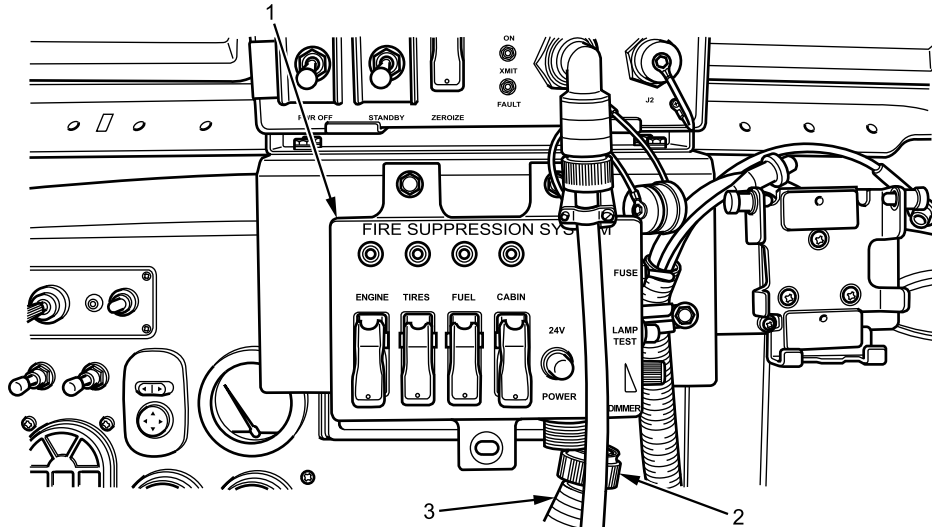

B237604980

Figure 1. Fire Suppression System (FSS) Harness Removal.

END OF TASK**INSTALLATION**

1. Position FSS harness (Figure 1, Item 3) on FSS control box (Figure 1, Item 1) and connect connector (Figure 1, Item 2).

END OF TASK**FOLLOW-ON MAINTENANCE**

1. Remove wheel chocks (TM 9-2355-106-10).

END OF TASK**END OF WORK PACKAGE**

FIELD MAINTENANCE

FIRE SUPPRESSION SYSTEM (FSS) CONTROL UNIT REMOVAL AND INSTALLATION

INITIAL SETUP:

Tools and Special Tools

General Mechanic's Tool Kit (GMTK)
(WP 0795, Item 37)

WP 0782

Materials/Parts

Grease (WP 0794, Item 22)

Equipment Condition

Parking brake set (TM 9-2355-106-10)
Transmission set in NEUTRAL (N) (TM
9-2355-106-10)
Engine off (TM 9-2355-106-10)
MAIN POWER switch off (TM 9-2355-106-10)
Wheels chocked (TM 9-2355-106-10)
FSS Disabled (WP 0736)

References

TM 9-2355-106-10
TM 9-2355-106-23P
WP 0786

WARNING



Prior to servicing Fire Suppression System (FSS), make sure FSS power is off, master battery disconnect switch is off, and FSS is disabled. Failure to comply may result in discharging of system and serious injury or death to personnel.

Use extreme caution when testing or working on or around electrical circuits. Always assume that electrical circuits are live. Electrical shock can occur upon contact with voltage high enough to cause current flow through muscles or nerves. On Direct Current (DC) systems, generally 1 milliamp of current can be felt, 5 milliamps can cause severe pain, 15 milliamps can cause loss of muscle control, and 70 milliamps can be fatal. Wear protective clothing; ensure skin, clothing, and surrounding areas are dry; do not wear jewelry; and touch only the insulated, nonmetallic parts of electrical components and testing equipment. To prevent electrical arcing, avoid shorting electrical test probes and jumper wires. Electrical arcing can cause bright flashes of light, capable of causing temporary blindness. If electrical injury occurs, immediately shut off power supply and seek medical assistance. Failure to comply may result in serious injury or death to personnel.

FIRE SUPPRESSION SYSTEM (FSS) CONTROL UNIT REMOVAL AND INSTALLATION - (CONTINUED)**REMOVAL**

1. Disconnect electrical cable (Figure 1, Item 3) from FSS control unit (Figure 1, Item 1).

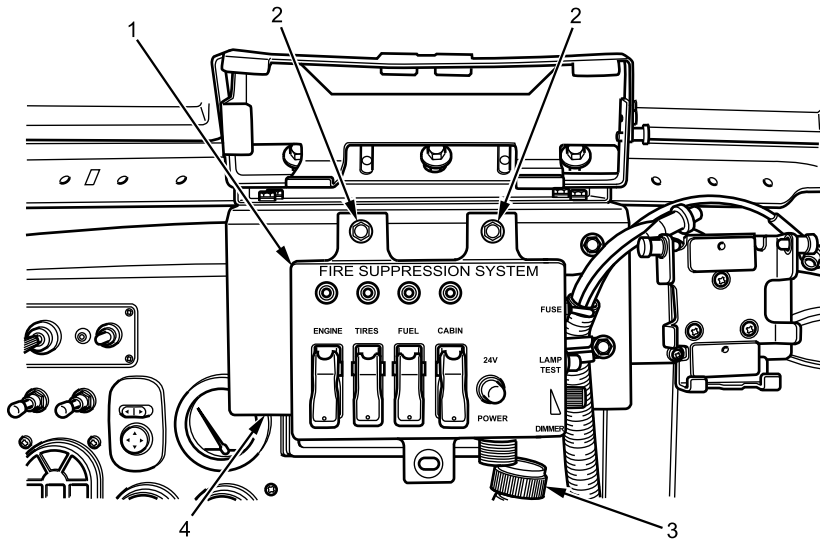

B230603310

Figure 1. FSS Control Unit.

2. Remove two bolts (Figure 1, Item 2) securing FSS control unit (Figure 1, Item 1) to bracket (Figure 1, Item 4).
3. Remove FSS control unit (Figure 1, Item 1).

END OF TASK**INSTALLATION****WARNING**

Dielectric grease is harmful to skin and eyes. If grease contacts eyes, rinse thoroughly and contact physician if irritation persists. If skin is contacted, wash thoroughly with soap and water. Failure to comply may result in serious injury to personnel.

NOTE

Apply dielectric grease to all electrical connections.

1. Position FSS control unit (Figure 2, Item 1) on bracket (Figure 2, Item 4).

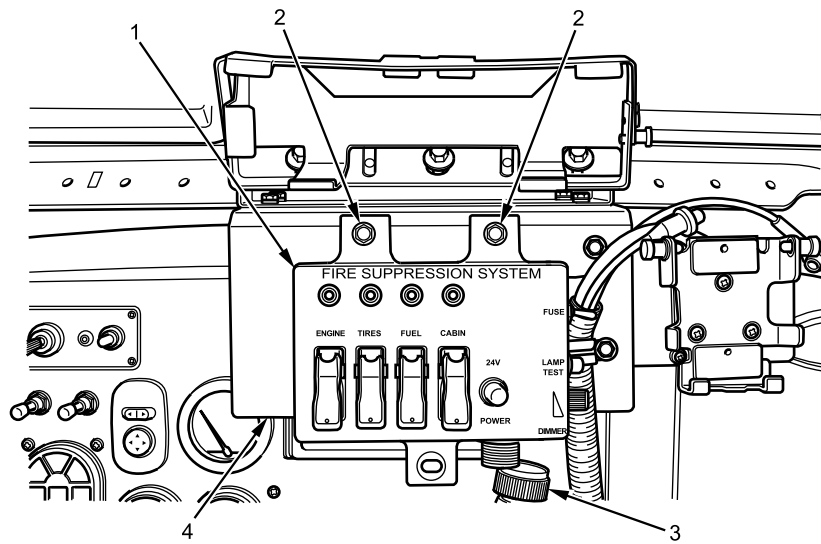
FIRE SUPPRESSION SYSTEM (FSS) CONTROL UNIT REMOVAL AND INSTALLATION - (CONTINUED)

B230603310

Figure 2. FSS Control Unit.

2. Install two bolts (Figure 2, Item 2) securing FSS control unit to bracket, Tighten bolts securely.
3. Connect electrical cable (Figure 2, Item 3) on FSS control unit (Figure 2, Item 1).

END OF TASK
FOLLOW-ON MAINTENANCE

1. Enable FSS (WP 0736).
2. Turn MAIN POWER switch on (TM 9-2355-106-10).
3. Press lamp test button on FSS control unit to verify operation (TM 9-2355-106-10).
4. Turn MAIN POWER switch off (TM 9-2355-106-10).
5. Remove wheel chocks (TM 9-2355-106-10).

END OF TASK
END OF WORK PACKAGE

FIELD MAINTENANCE

FIRE SUPPRESSION SYSTEM (FSS) CONTROL UNIT BRACKET REMOVAL AND INSTALLATION

INITIAL SETUP:

Tools and Special Tools

General Mechanic's Tool Kit (GMTK)
(WP 0795, Item 37)

Materials/Parts

Lockwasher - (3) (WP 0796, Item 179)

References

TM 9-2355-106-10
TM 9-2355-106-23P
WP 0786

WP 0782

Equipment Condition

Parking brake set (TM 9-2355-106-10)
Transmission set in NEUTRAL (N) (TM
9-2355-106-10)
Engine off (TM 9-2355-106-10)
MAIN POWER switch off (TM 9-2355-106-10)
Wheels chocked (TM 9-2355-106-10)
Fire suppression system (FSS) control unit removed
(WP 0737)

REMOVAL

1. Pull out on pin (Figure 1, Item 2) and tilt communication bracket (Figure 1, Item 1) upwards, if equipped.

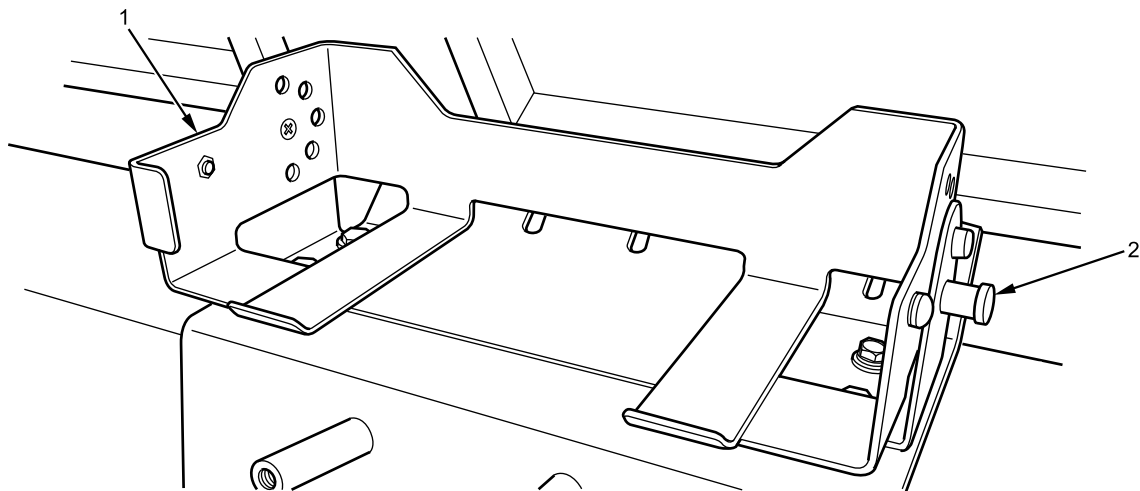

B230601235

Figure 1. Communication Bracket.

2. Remove three bolts, lockwashers, and washers (Figure 2, Item 1) securing FSS control bracket (Figure 2, Item 2) to cross-vehicle equipment bracket (Figure 2, Item 3). Discard lockwashers.

FIRE SUPPRESSION SYSTEM (FSS) CONTROL UNIT BRACKET REMOVAL AND INSTALLATION - (CONTINUED)

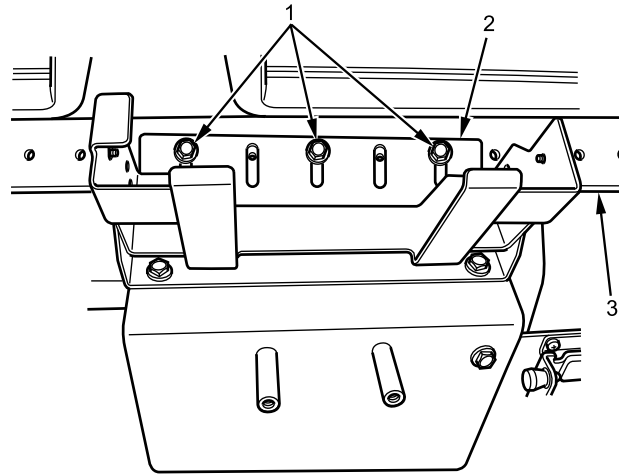

B230601236

Figure 2. FSS Bracket Bolts.

3. Remove FSS control bracket (Figure 2, Item 2).

END OF TASK

INSTALLATION

1. Install three bolts, washers, and new lockwashers (Figure 3, Item 1) securing FSS control bracket (Figure 3, Item 2) to cross-vehicle equipment bracket (Figure 3, Item 3). Tighten bolts securely.

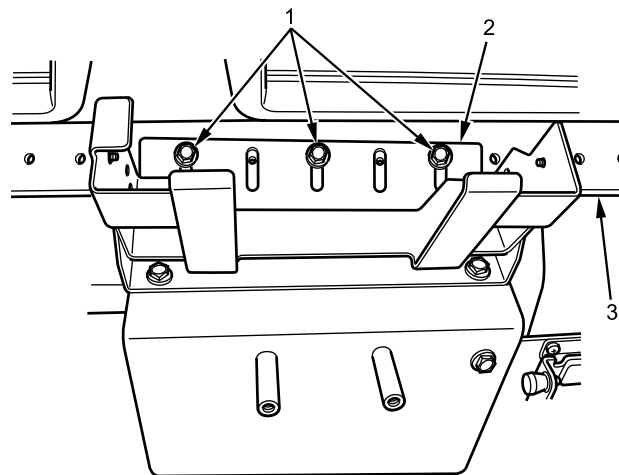

B230601236

Figure 3. FSS Bracket Bolts.

2. Pull out on pin (Figure 4, Item 2) and tilt communication bracket (Figure 4, Item 1) down to level position, if equipped.

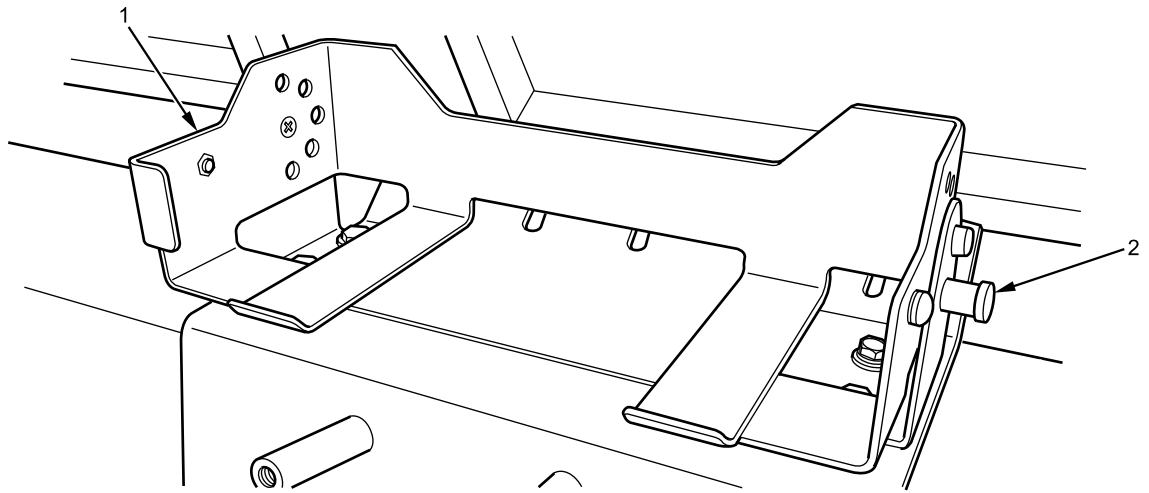
**FIRE SUPPRESSION SYSTEM (FSS) CONTROL UNIT BRACKET REMOVAL AND INSTALLATION -
(CONTINUED)**

B230601235

Figure 4. Communication Bracket.

END OF TASK**FOLLOW-ON MAINTENANCE**

1. Install FSS control unit (WP 0737).
2. Remove wheel chocks (TM 9-2355-106-10).

END OF TASK**END OF WORK PACKAGE**

FIELD MAINTENANCE

FIRE SUPPRESSION SYSTEM (FSS) CABIN HARNESS REMOVAL AND INSTALLATION

INITIAL SETUP:

Tools and Special Tools

General Mechanic's Tool Kit (GMTK)
(WP 0795, Item 37)

WP 0786

WP 0782

Materials/Parts

Grease (WP 0794, Item 22)
Lockwashers - (4) (WP 0796, Item 23)
Cable lock strap - (8) (WP 0796, Item 120)

Equipment Condition

Parking brake set (TM 9-2355-106-10)
Transmission set in NEUTRAL (N) (TM
9-2355-106-10)
Engine off (TM 9-2355-106-10)
MAIN POWER switch off (TM 9-2355-106-10)
Wheels chocked (TM 9-2355-106-10)
Right cabin door secured safely open (WP 0608)
FSS disabled (WP 0736)

References

TM 9-2355-106-10
TM 9-2355-106-23P

WARNING



Use extreme caution when testing or working on or around electrical circuits. Always assume that electrical circuits are live. Electrical shock can occur upon contact with voltage high enough to cause current flow through muscles or nerves. On Direct Current (DC) systems, generally 1 milliamp of current can be felt, 5 milliamps can cause severe pain, 15 milliamps can cause loss of muscle control, and 70 milliamps can be fatal. Wear protective clothing; ensure skin, clothing, and surrounding areas are dry; do not wear jewelry; and touch only the insulated, nonmetallic parts of electrical components and testing equipment. To prevent electrical arcing, avoid shorting electrical test probes and jumper wires. Electrical arcing can cause bright flashes of light, capable of causing temporary blindness. If electrical injury occurs, immediately shut off power supply and seek medical assistance. Failure to comply may result in serious injury or death to personnel.

Use caution when working around Fire Suppression System (FSS). Do not release extinguisher cylinder mounting straps, and do not bump or strike extinguisher. Disturbing the pyrotechnic actuator or pressure switch may cause extinguisher to discharge accidentally. Extinguisher cylinder can move violently when discharging. Failure to comply may result in damage to equipment and serious injury or death to personnel.

Cabin door must be secured in the open position by using heavy duty winch straps to prevent accidental closure during vehicle maintenance. Pull door hinge pin prior to securing door open. Failure to comply may result in serious injury or death to personnel.

Use the appropriate lifting strap sling or chain hoist for the type of load. Always clean and inspect lifting strap slings and chain hoists prior to use. Inspect for damage such as wear, corrosion, elongation, tears, or punctures. Replace lifting strap slings or chain hoists that are damaged. Failure to comply may result in component damage and death or injury to personnel.

FIRE SUPPRESSION SYSTEM (FSS) CABIN HARNESS REMOVAL AND INSTALLATION - (CONTINUED)

NOTE

Remove cable lock straps as necessary to perform procedure. Note position and size of cable lock straps to aid installation.

Note harness routing to aid in installation.

REMOVAL

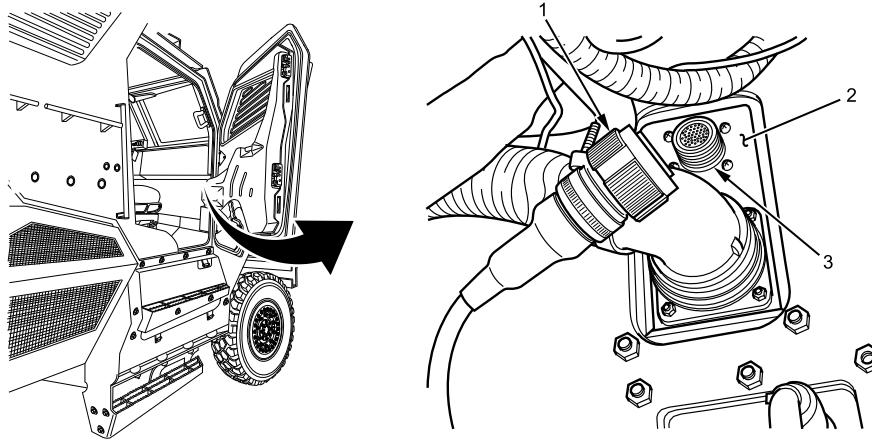

B230604997

Figure 1. Interior Pass-Through Plate Connection.

1. Disconnect FSS cabin harness connector (Figure 1, Item 1) from FSS chassis harness connector (Figure 1, Item 3) at pass-through plate (Figure 1, Item 2).

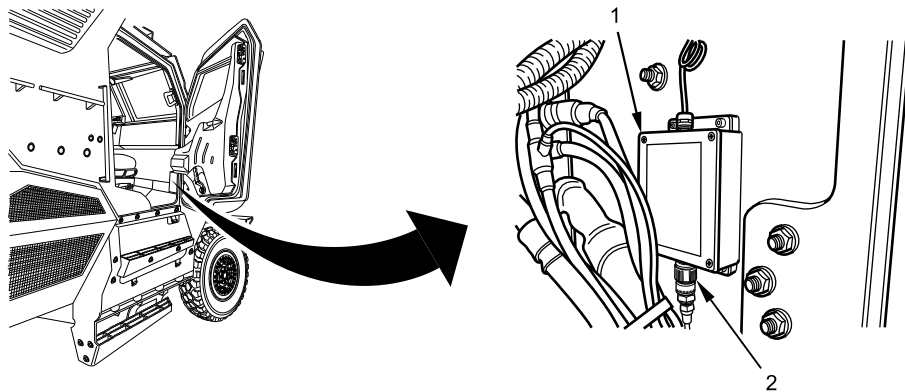

B230610231

Figure 2. FSS Control Unit.

2. Disconnect FSS cabin harness connector (Figure 2, Item 2) from FSS control unit (Figure 2, Item 1).

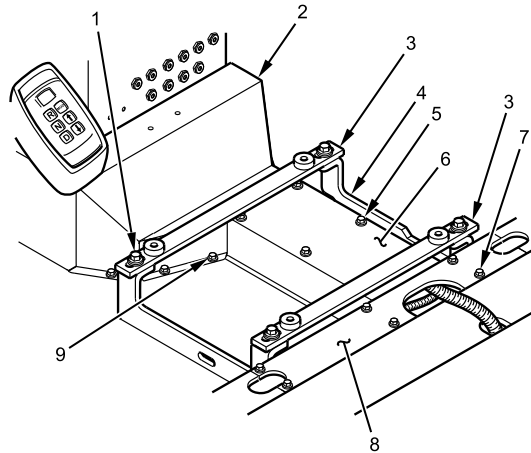
FIRE SUPPRESSION SYSTEM (FSS) CABIN HARNESS REMOVAL AND INSTALLATION - (CONTINUED)

B230605050

Figure 3. Power Distribution Module (PDM) Harness Electrical Storage Shield and Duct Covers.

3. Remove four bolts (Figure 3, Item 1), lockwashers, and flat washers, and remove two crossbars (Figure 3, Item 3) mounted to center mounting brackets (Figure 3, Item 4). Discard lockwashers.
4. Remove eight bolts (Figure 3, Item 9) and PDM harness electrical storage shield (Figure 3, Item 2).
5. Remove six bolts (Figure 3, Item 5) and electrical harness storage duct center cover (Figure 3, Item 6).
6. Remove six bolts (Figure 3, Item 7) and electrical harness storage duct rear center cover (Figure 3, Item 8).

FIRE SUPPRESSION SYSTEM (FSS) CABIN HARNESS REMOVAL AND INSTALLATION - (CONTINUED)

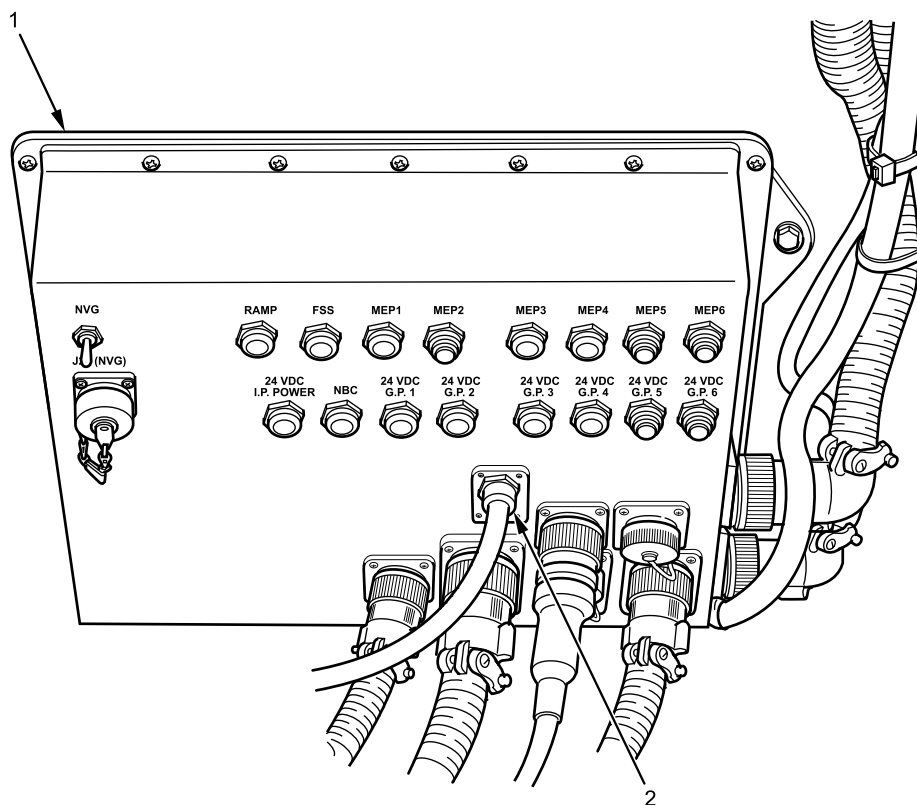

B230604999

Figure 4. FSS Connector.

7. Disconnect FSS harness connector (Figure 4, Item 2) from PDM (Figure 4, Item 1).

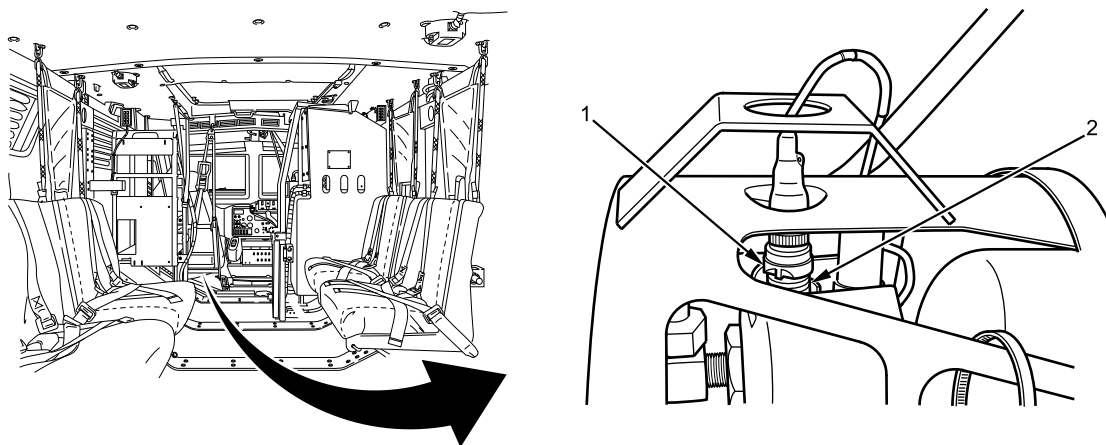

B230610232

Figure 5. FSS Cabin Cylinder Connection.

8. Disconnect FSS cabin harness connector (Figure 5, Item 1) from FSS cabin cylinder (Figure 5, Item 2).
9. Remove and discard cable lock straps. Remove FSS cabin harness from vehicle.

END OF TASK

FIRE SUPPRESSION SYSTEM (FSS) CABIN HARNESS REMOVAL AND INSTALLATION - (CONTINUED)**INSTALLATION****WARNING**

Dielectric grease is harmful to skin and eyes. If grease contacts eyes, rinse thoroughly and contact physician if irritation persists. If skin is contacted, wash thoroughly with soap and water. Failure to comply may result in serious injury to personnel.

NOTE

Apply dielectric grease to all FSS chassis harness connectors before installation.

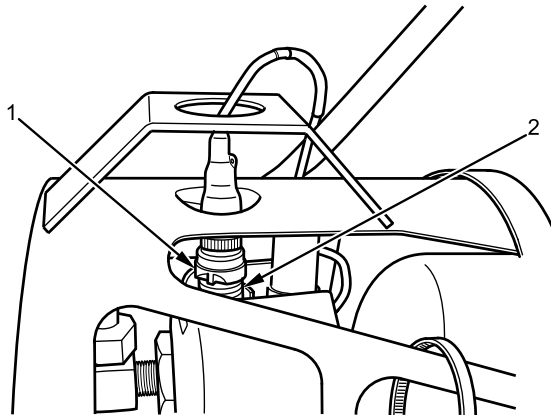

B230605277

Figure 6. FSS Cabin Cylinder Connection.

1. Position FSS cabin harness in vehicle. Connect FSS cabin harness connector (Figure 6, Item 1) to FSS cabin cylinder (Figure 6, Item 2).

FIRE SUPPRESSION SYSTEM (FSS) CABIN HARNESS REMOVAL AND INSTALLATION - (CONTINUED)

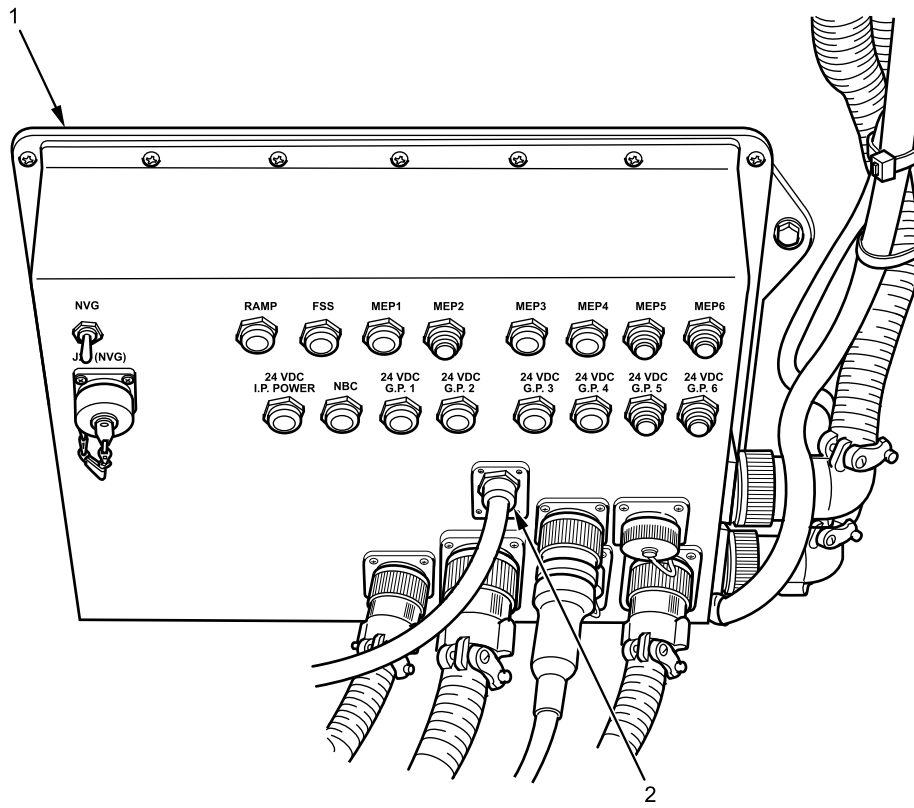

B230604999

Figure 7. FSS Connector.

2. Connect FSS harness connector (Figure 7, Item 2) to PDM (Figure 7, Item 1).

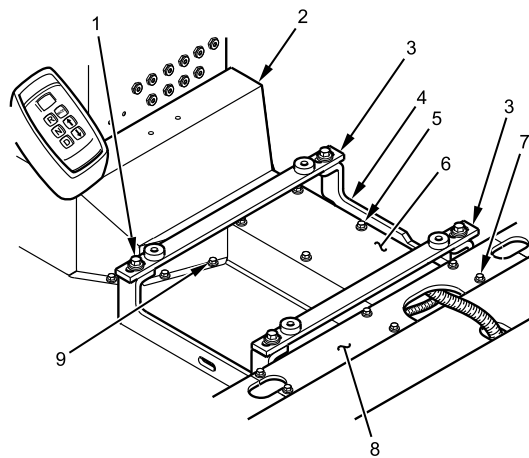

B230605050

Figure 8. PDM Harness Electrical Storage Shield and Duct Covers.

NOTE

To facilitate alignment of crossbar boltholes, loosen center mounting bracket bolts on floor.

3. Install electrical harness storage duct rear center cover (Figure 8, Item 8) with six bolts (Figure 8, Item 7). Tighten bolts securely.

FIRE SUPPRESSION SYSTEM (FSS) CABIN HARNESS REMOVAL AND INSTALLATION - (CONTINUED)

4. Install electrical harness storage duct center cover (Figure 8, Item 6) with six bolts (Figure 8, Item 5). Tighten securely.
5. Install PDM harness electrical storage shield (Figure 8, Item 2) with eight bolts (Figure 8, Item 9). Tighten bolts securely.
6. Install two crossbars (Figure 8, Item 3) on center mounting brackets (Figure 8, Item 4) with four bolts (Figure 8, Item 1), flat washers, and new lockwashers. Tighten bolts securely.

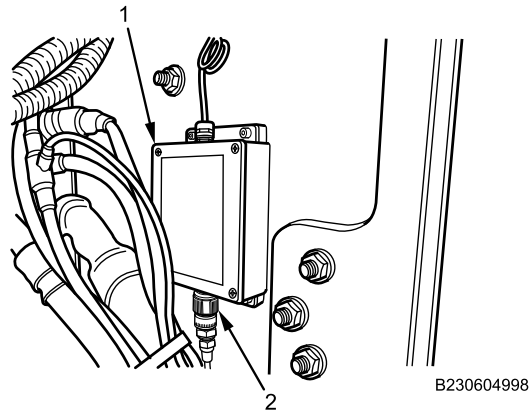

Figure 9. FSS Control Unit.

7. Connect FSS cabin harness connector (Figure 9, Item 2) to FSS control unit (Figure 9, Item 1).

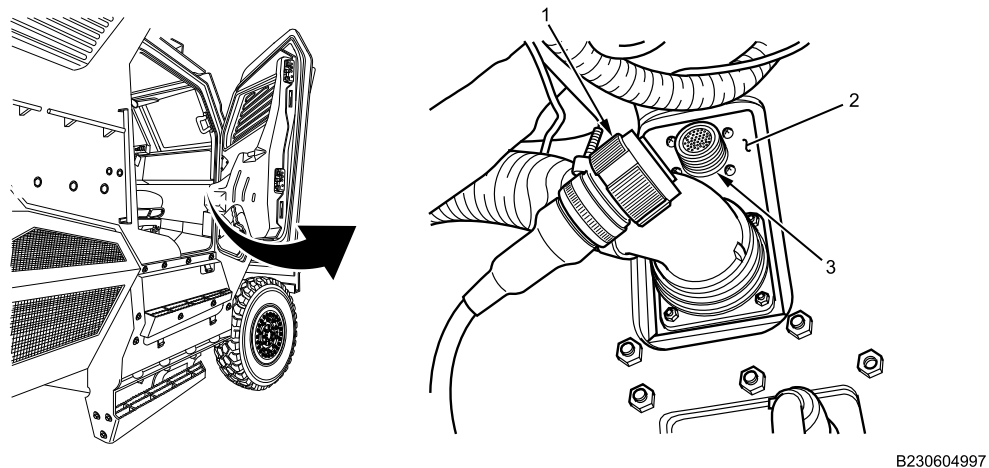

Figure 10. Interior Pass-Through Plate Connection.

8. Connect FSS cabin harness connector (Figure 10, Item 1) to FSS chassis harness connector (Figure 10, Item 3) at pass-through plate (Figure 10, Item 2).
9. Install all cable lock straps and tighten securely.

END OF TASK

FIRE SUPPRESSION SYSTEM (FSS) CABIN HARNESS REMOVAL AND INSTALLATION - (CONTINUED)**FOLLOW-ON MAINTENANCE**

1. Enable FSS (WP 0741).
2. Close right cabin door (WP 0608).
3. Remove wheel chocks (TM 9-2355-106-10).

END OF TASK**END OF WORK PACKAGE**

FIELD MAINTENANCE**FIRE SUPPRESSION SYSTEM (FSS) CHASSIS HARNESS REMOVAL AND INSTALLATION**

INITIAL SETUP:**Tools and Special Tools**

General Mechanic's Tool Kit (GMTK)
(WP 0795, Item 37)

Materials/Parts

Grease (WP 0794, Item 22)
Cable lock strap - (8) (WP 0796, Item 120)
Cable lock strap - (3) (WP 0796, Item 136)

Personnel Required

Maintainer - (2)

References

TM 9-2355-106-10
TM 9-2355-106-23P
WP 0782

Equipment Condition

Parking brake set (TM 9-2355-106-10)

Transmission set in NEUTRAL (N) (TM
9-2355-106-10)

Engine off (TM 9-2355-106-10)

MAIN POWER switch off (TM 9-2355-106-10)

Wheels chocked (TM 9-2355-106-10)

Right cabin door secured safely open (WP 0608)

Hood open and secured (TM 9-2355-106-10)

FSS disabled (WP 0736)

Instrument Panel (IP) right side closeout removed
(WP 0580)

Left rear stowage box removed (WP 0676)

Belly armor removed (WP 0606)

Left Air Conditioning (A/C) condenser panel removed
(WP 0672)

Right Air Conditioning (A/C) condenser panel
removed (WP 0672)

FIRE SUPPRESSION SYSTEM (FSS) CHASSIS HARNESS REMOVAL AND INSTALLATION - (CONTINUED)**WARNING**

Use extreme caution when testing or working on or around electrical circuits. Always assume that electrical circuits are live. Electrical shock can occur upon contact with voltage high enough to cause current flow through muscles or nerves. On Direct Current (DC) systems, generally 1 milliamp of current can be felt, 5 milliamps can cause severe pain, 15 milliamps can cause loss of muscle control, and 70 milliamps can be fatal. Wear protective clothing; ensure skin, clothing, and surrounding areas are dry; do not wear jewelry; and touch only the insulated, nonmetallic parts of electrical components and testing equipment. To prevent electrical arcing, avoid shorting electrical test probes and jumper wires. Electrical arcing can cause bright flashes of light, capable of causing temporary blindness. If electrical injury occurs, immediately shut off power supply and seek medical assistance. Failure to comply may result in serious injury or death to personnel.

Cabin door must be secured in the open position by using heavy duty winch straps to prevent accidental closure during vehicle maintenance. Pull door hinge pin prior to securing door open. Failure to comply may result in serious injury or death to personnel.

Use the appropriate lifting strap sling or chain hoist for the type of load. Always clean and inspect lifting strap slings and chain hoists prior to use. Inspect for damage such as wear, corrosion, elongation, tears, or punctures. Replace lifting strap slings or chain hoists that are damaged. Failure to comply may result in component damage and death or injury to personnel.

Prior to servicing Fire Suppression System (FSS), make sure FSS power is off, master MAIN POWER switch is off, and FSS is disabled. Failure to comply may result in discharging of system and serious injury or death to personnel.

Do not release extinguisher cylinder mounting straps when disconnecting or connecting FSS electrical harness. Disturbing the pyrotechnic actuator or pressure switch may cause extinguisher to discharge accidentally. Extinguisher cylinder can move violently when discharging. Failure to comply may result in damage to equipment and serious injury or death to personnel.

REMOVAL**NOTE**

Record location of cable lock straps to aid in installation.

Note routing of FSS chassis harness on underside of hood before removal to aid in installation.

1. Disconnect FSS chassis harness connector (Figure 1, Item 2) from FSS engine compartment sensor (Figure 1, Item 1).
2. Remove and discard cable lock straps (Figure 1, Item 4) from FSS chassis harness (Figure 1, Item 3) on inside of engine hood (Figure 1, Item 5).

FIRE SUPPRESSION SYSTEM (FSS) CHASSIS HARNESS REMOVAL AND INSTALLATION - (CONTINUED)

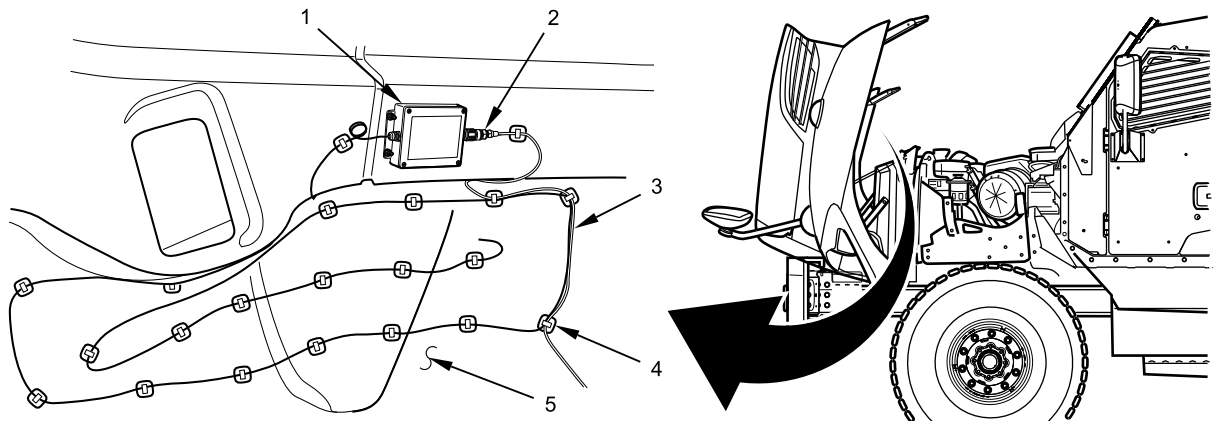

005390

Figure 1. FSS Engine Compartment Sensor Connection.

NOTE

FSS engine extinguisher bottle is located on right side of vehicle on frame rail.

3. Disconnect FSS chassis harness connector (Figure 2, Item 2) from FSS engine extinguisher cylinder (Figure 2, Item 1).

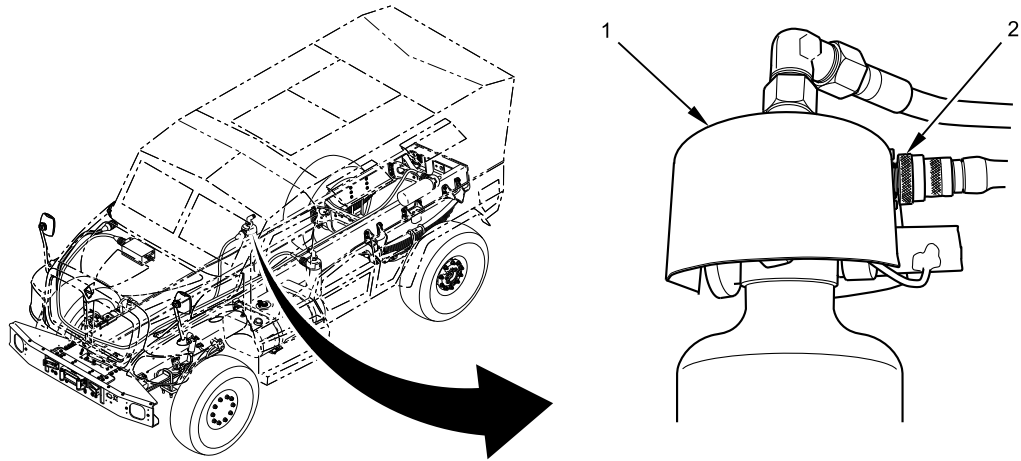

005391

Figure 2. FSS Cylinder Connection.

FIRE SUPPRESSION SYSTEM (FSS) CHASSIS HARNESS REMOVAL AND INSTALLATION - (CONTINUED)

4. Disconnect FSS chassis harness connector (Figure 3, Item 2) from FSS fuel tank extinguisher cylinder (Figure 3, Item 1).

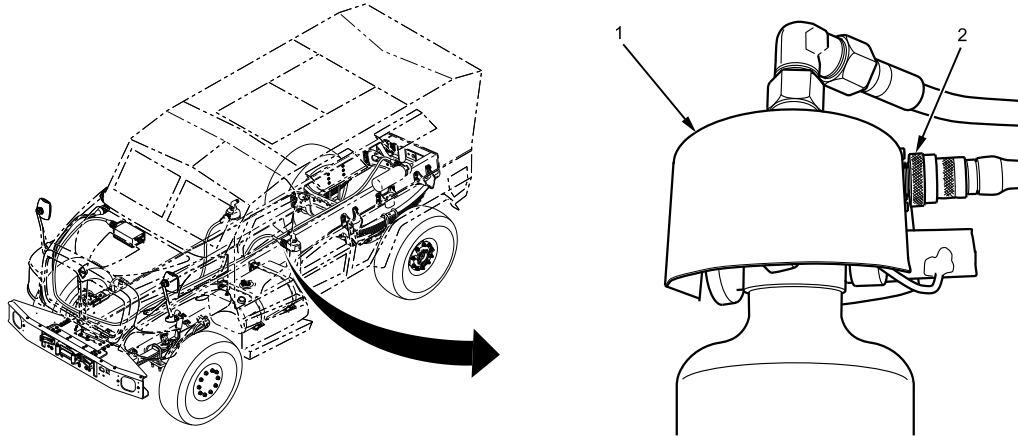

B230604848

Figure 3. FSS Fuel Tank Extinguisher Cylinder Connection.

5. Disconnect FSS chassis harness connector (Figure 4, Item 2) from FSS tire extinguisher cylinder (Figure 4, Item 1) and remove FSS chassis harness (Figure 4, Item 3).

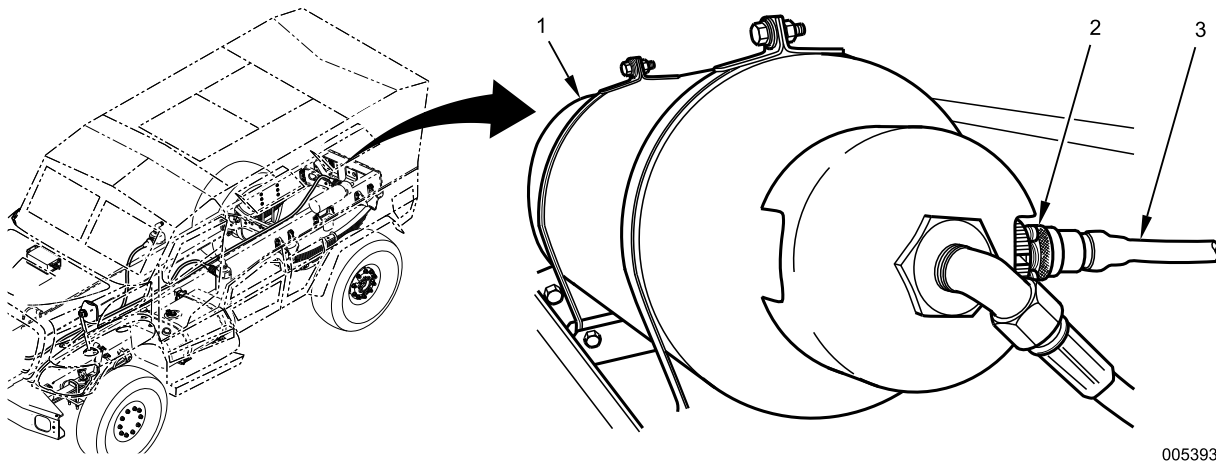

005393

Figure 4. FSS Tire Extinguisher Cylinder Connection.

FIRE SUPPRESSION SYSTEM (FSS) CHASSIS HARNESS REMOVAL AND INSTALLATION - (CONTINUED)

6. Disconnect FSS cabin harness connector (Figure 5, Item 1) from FSS chassis harness connector (Figure 5, Item 4).
7. With assistant on exterior side of pass-through plate, remove four nuts (Figure 5, Item 2) from interior side of pass-through plate (Figure 5, Item 3).

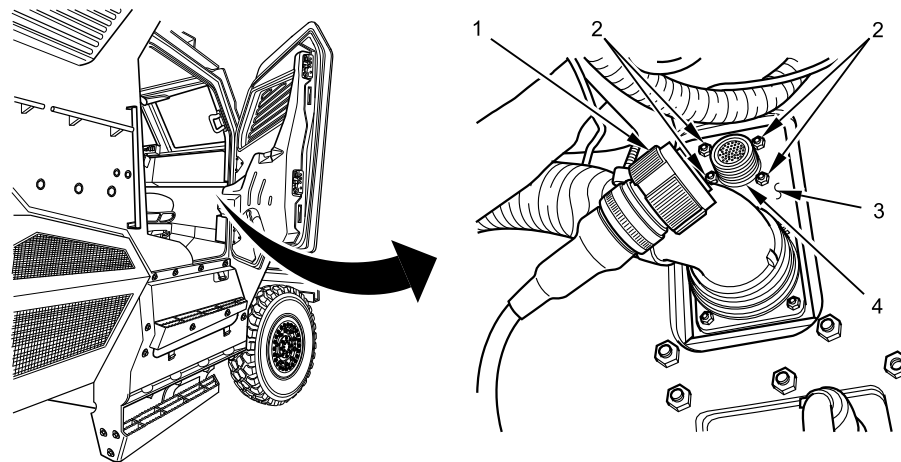

005394

Figure 5. Interior Side of Pass-Through Plate.

8. With assistant on interior side of pass-through plate, remove four screws (Figure 6, Item 3) (one hidden) from exterior FSS chassis harness connector (Figure 6, Item 1).
9. Remove FSS chassis harness (Figure 6, Item 2) from exterior side of pass-through plate (Figure 6, Item 4).

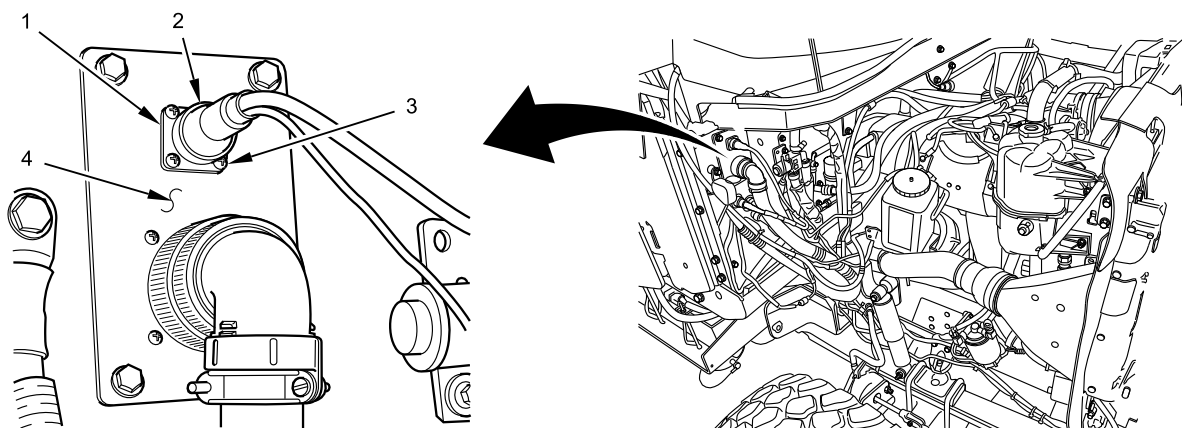

005395

Figure 6. Exterior Side of Pass-Through Plate.

END OF TASK

FIRE SUPPRESSION SYSTEM (FSS) CHASSIS HARNESS REMOVAL AND INSTALLATION - (CONTINUED)**INSTALLATION****WARNING**

Dielectric grease is harmful to skin and eyes. If grease contacts eyes, rinse thoroughly and contact physician if irritation persists. If skin is contacted, wash thoroughly with soap and water. Failure to comply may result in serious injury to personnel.

NOTE

Apply dielectric grease to FSS chassis harness connectors before installation.

1. Position FSS chassis harness (Figure 7, Item 2) on exterior side of pass-through plate (Figure 7, Item 4).
2. Install four screws (Figure 7, Item 3) (one hidden) on FSS chassis harness connector (Figure 7, Item 1).

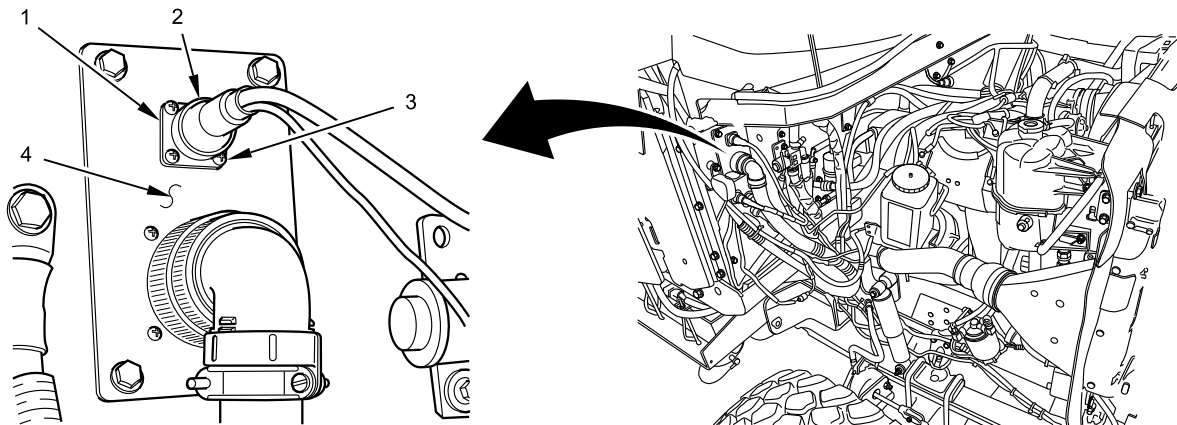

005395

Figure 7. Exterior Side of Pass-Through Plate.

FIRE SUPPRESSION SYSTEM (FSS) CHASSIS HARNESS REMOVAL AND INSTALLATION - (CONTINUED)

3. With assistant on exterior side of pass-through plate, install four nuts (Figure 8, Item 2) on interior side of pass-through plate (Figure 8, Item 3). Tighten nuts securely.
4. Connect FSS cabin harness connector (Figure 8, Item 1) to FSS chassis harness connector (Figure 8, Item 4).

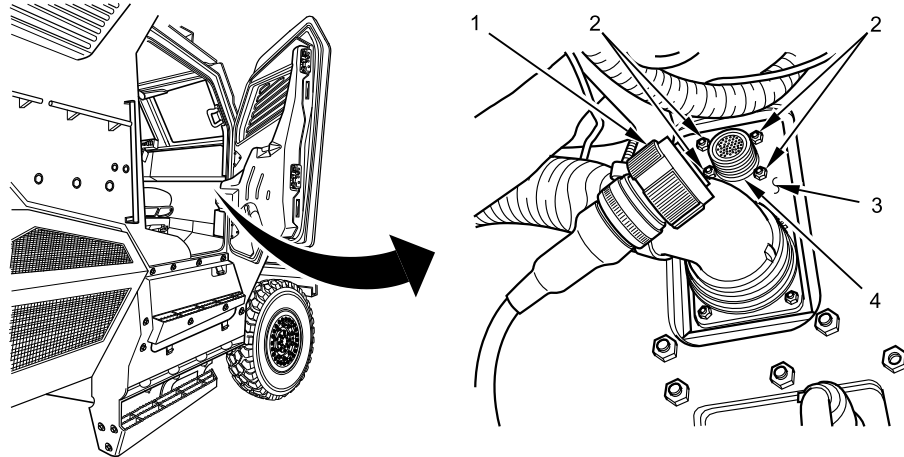

005394

Figure 8. Interior Side of Pass-Through Plate.

5. Position FSS chassis harness (Figure 9, Item 3). Connect FSS chassis harness connector (Figure 9, Item 2) to FSS tire extinguisher cylinder (Figure 9, Item 1).

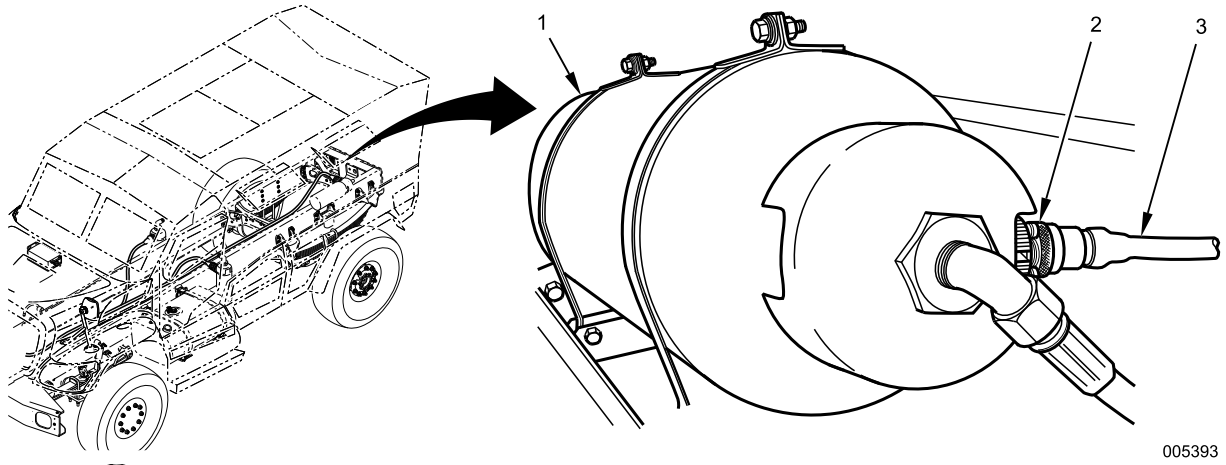

005393

Figure 9. FSS Tire Extinguisher Cylinder Connection.

FIRE SUPPRESSION SYSTEM (FSS) CHASSIS HARNESS REMOVAL AND INSTALLATION - (CONTINUED)

6. Connect FSS chassis harness connector (Figure 10, Item 2) to FSS fuel tank extinguisher cylinder (Figure 10, Item 1).

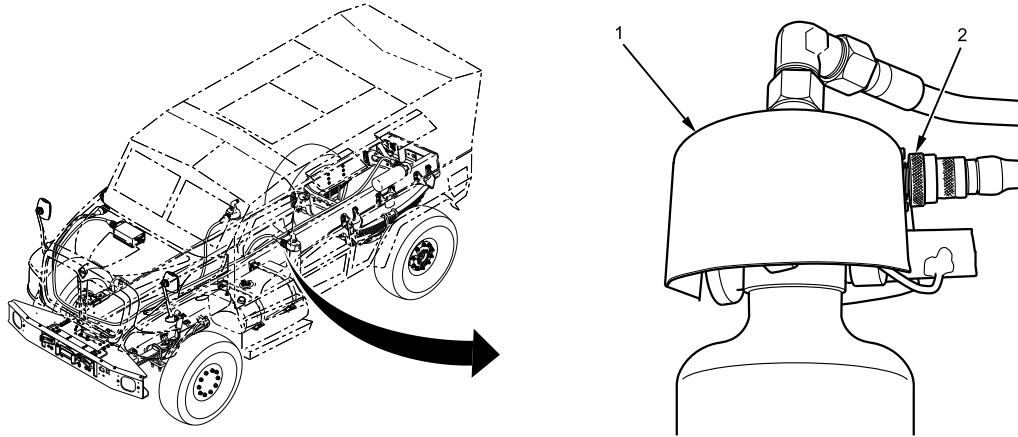

B230604848

Figure 10. FSS Fuel Tank Extinguisher Cylinder Connection.

7. Connect FSS chassis harness connector (Figure 11, Item 2) to FSS engine extinguisher cylinder (Figure 11, Item 1).

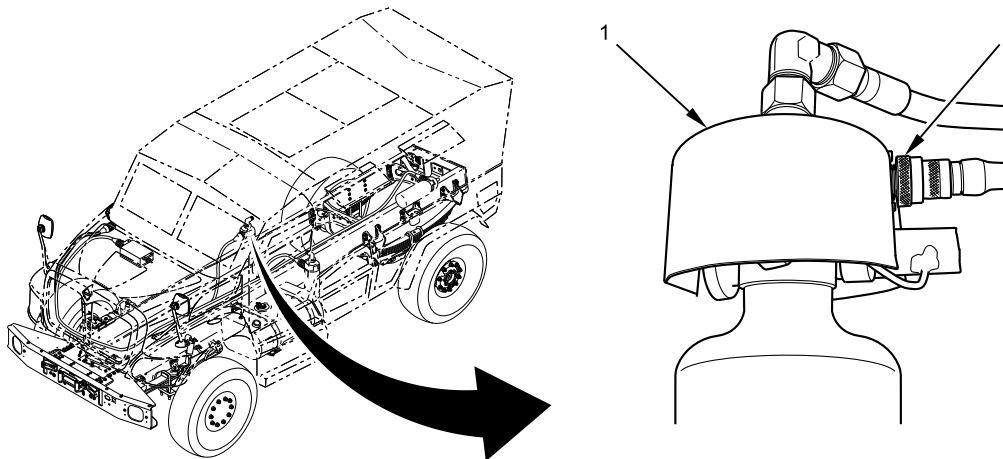

005391

Figure 11. FSS Engine Extinguisher Cylinder Connection.

8. Connect FSS chassis harness connector (Figure 12, Item 2) to FSS engine compartment sensor (Figure 12, Item 1).

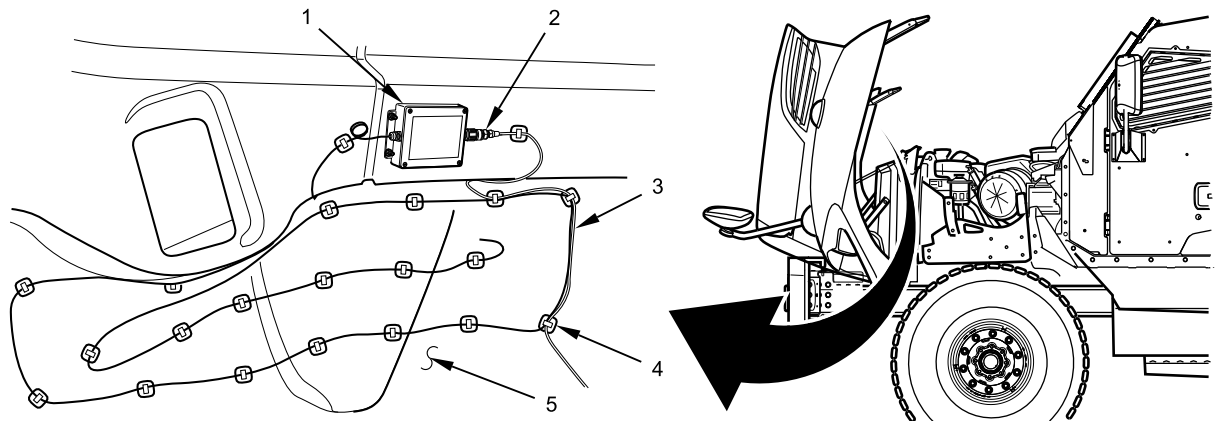
FIRE SUPPRESSION SYSTEM (FSS) CHASSIS HARNESS REMOVAL AND INSTALLATION - (CONTINUED)

005390

Figure 12. FSS Engine Compartment Sensor Connection.

9. Install cable lock straps as noted in removal.

END OF TASK**FOLLOW-ON MAINTENANCE**

1. Install left A/C condenser panel (WP 0672).
2. Install right A/C condenser panel (WP 0672).
3. Install left rear stowage box (WP 0676).
4. Install IP right side closeout (WP 0580).
5. Enable FSS (WP 0736).
6. Install belly armor (WP 0606).
7. Close engine hood (TM 9-2355-106-10).
8. Close right cabin door (WP 0608).
9. Remove wheel chocks (TM 9-2355-106-10).

END OF TASK**END OF WORK PACKAGE**

FIELD MAINTENANCE
FIRE SUPPRESSION SYSTEM (FSS) ENGINE COMPARTMENT SENSOR REMOVAL AND INSTALLATION

INITIAL SETUP:**Tools and Special Tools**

General Mechanic's Tool Kit (GMTK)
(WP 0795, Item 37)

WP 0782

Materials/Parts

Grease (WP 0794, Item 22)
Cable lock strap (WP 0796, Item 120)

Equipment Condition

Parking brake set (TM 9-2355-106-10)
Transmission set in NEUTRAL (N) (TM 9-2355-106-10)
Engine off (TM 9-2355-106-10)
MAIN POWER switch off (TM 9-2355-106-10)
Wheels chocked (TM 9-2355-106-10)
Hood open and secured (TM 9-2355-106-10)
Disable FSS (WP 0736)

References

TM 9-2355-106-10
TM 9-2355-106-23P
WP 0786

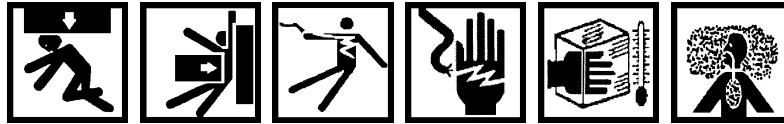
WARNING

Engine hood is extremely heavy and requires two-person lift. Ensure that there is adequate space in front of the vehicle to open hood completely without pinning or pinching personnel between hood and any other structure. Use extreme care when working under hood and make sure it is properly supported. Failure to comply may result in serious injury or death to personnel.

Use extreme caution when testing or working on or around electrical circuits. Always assume that electrical circuits are live. Electrical shock can occur upon contact with voltage high enough to cause current flow through muscles or nerves. On Direct Current (DC) systems, generally 1 milliamp of current can be felt, 5 milliamps can cause severe pain, 15 milliamps can cause loss of muscle control, and 70 milliamps can be fatal. Wear protective clothing; ensure skin, clothing, and surrounding areas are dry; do not wear jewelry; and touch only the insulated, nonmetallic parts of electrical components and testing equipment. To prevent electrical arcing, avoid shorting electrical test probes and jumper wires. Electrical arcing can cause bright flashes of light, capable of causing temporary blindness. If electrical injury occurs, immediately shut off power supply and seek medical assistance. Failure to comply may result in serious injury or death to personnel.

Prior to servicing Fire Suppression System (FSS), make sure FSS power is off, and FSS is disabled. Failure to comply may result in discharging of system and serious injury or death to personnel.

FIRE SUPPRESSION SYSTEM (FSS) ENGINE COMPARTMENT SENSOR REMOVAL AND INSTALLATION - (CONTINUED)

REMOVAL

NOTE

Note routing of FSS engine sensor wire before removal. Draw a diagram if necessary to ensure proper location is maintained on installation.

Do not cut or damage FSS engine sensor wire when removing cable lock straps from retainers.

1. Remove two electrical connectors (Figure 1, Item 3) from FSS engine compartment sensor (Figure 1, Item 2).

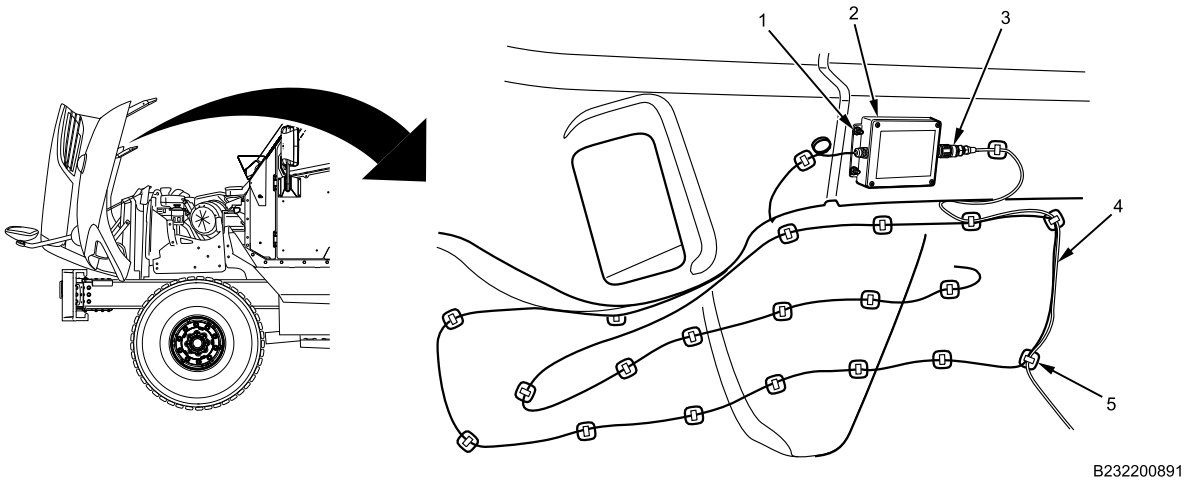

B232200891

Figure 1. FSS Engine Compartment Sensor Connections.

2. Remove all cable lock straps (Figure 1, Item 5) from engine sensor wire (Figure 1, Item 4).
3. Remove four bolts and locknuts (Figure 1, Item 1) securing FSS engine compartment sensor (Figure 1, Item 2) to hood.
4. Remove FSS engine compartment sensor (Figure 1, Item 2) from bottom of hood.

END OF TASK

FIRE SUPPRESSION SYSTEM (FSS) ENGINE COMPARTMENT SENSOR REMOVAL AND INSTALLATION - (CONTINUED)**INSTALLATION****WARNING**

Dielectric grease is harmful to skin and eyes. If grease contacts eyes, rinse thoroughly and contact physician if irritation persists. If skin is contacted, wash thoroughly with soap and water. Failure to comply may result in serious injury to personnel.

NOTE

Apply dielectric grease to all electrical connections.

1. Position FSS engine compartment sensor (Figure 1, Item 2) on bottom of hood.
2. Install four bolts and locknuts (Figure 1, Item 1) to FSS engine compartment sensor (Figure 1, Item 2). Tighten bolts securely.
3. Install two electrical connectors (Figure 1, Item 3) on FSS engine compartment sensor (Figure 1, Item 2).
4. Carefully install engine sensor wire (Figure 1, Item 4) on bottom of hood, securing engine sensor wire to all retainers (Figure 1, Item 5) with cable lock straps.

END OF TASK**FOLLOW-ON MAINTENANCE**

1. Enable FSS (WP 0736).
2. Close engine hood (TM 9-2355-106-10).
3. Remove wheel chocks (TM 9-2355-106-10).

END OF TASK**END OF WORK PACKAGE**

FIELD MAINTENANCE

FIRE SUPPRESSION SYSTEM (FSS) CABIN SENSOR REMOVAL AND INSTALLATION

INITIAL SETUP:

Tools and Special Tools

General Mechanic's Tool Kit (GMTK)
(WP 0795, Item 37)

Materials/Parts

Grease (WP 0794, Item 22)

References

TM 9-2355-106-10
TM 9-2355-106-23P
WP 0786
WP 0782

Equipment Condition

Parking brake set (TM 9-2355-106-10)
Transmission set in NEUTRAL (N) (TM 9-2355-106-10)
Engine off (TM 9-2355-106-10)
MAIN POWER switch off (TM 9-2355-106-10)
Wheels chocked (TM 9-2355-106-10)
Fire Suppression System (FSS) Disable and Enable (WP 0736)
A-pillar Cover Trim Removed (WP 0642)
Cabin Roof Moldings Removed (WP 0583)

REMOVAL

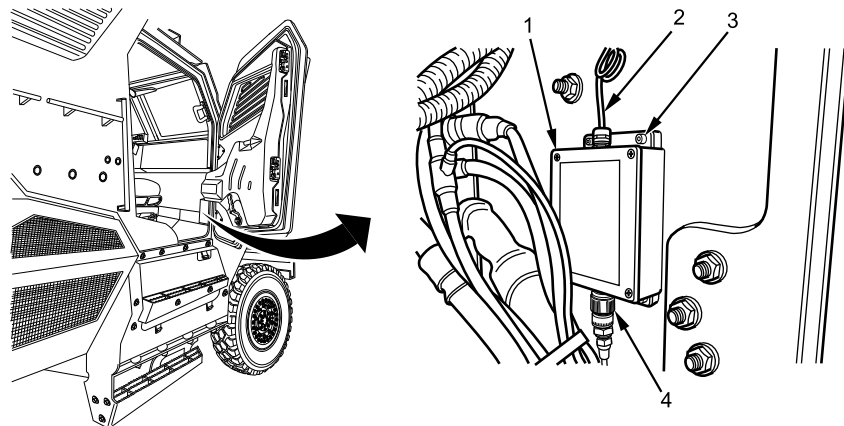

B237603324

Figure 1. FSS Cabin Compartment Sensor Connections.

1. Remove lower connector (Figure 1, Item 4) from FSS cabin compartment sensor (Figure 1, Item 1).
2. Remove four screws (Figure 1, Item 3) securing FSS cabin compartment sensor (Figure 1, Item 1) to right lower hinge pillar.

CAUTION

Do not allow sharp bends in FSS sensor tubing. Damage to sensor tubing could result.

NOTE

Tubing is part of sensor and is not removable.

Note routing of FSS sensor tubing to aid in installation.

3. Remove FSS sensor tubing (Figure 1, Item 2) from A-pillar and cabin wiring harness roof channels. Remove sensor (Figure 1, Item 1).

END OF TASK

FIRE SUPPRESSION SYSTEM (FSS) CABIN SENSOR REMOVAL AND INSTALLATION - (CONTINUED)**INSTALLATION****WARNING**

Dielectric grease is harmful to skin and eyes. If grease contacts eyes, rinse thoroughly and contact physician if irritation persists. If skin is contacted, wash thoroughly with soap and water. Failure to comply may result in serious injury to personnel.

NOTE

Apply dielectric grease to electrical connector.

1. Position FSS sensor tubing (Figure 2, Item 2) inside cabin wiring harness roof channels as noted during removal.

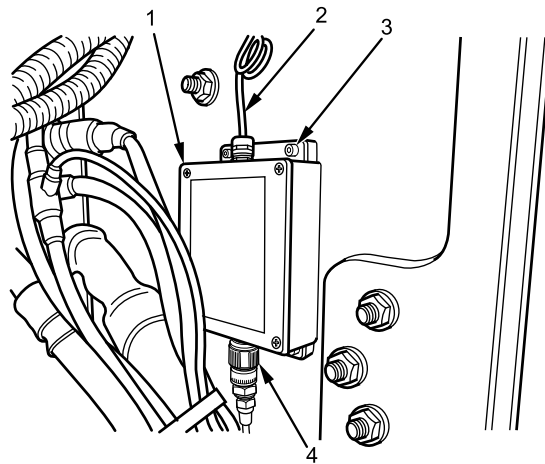

B237603326

Figure 2. FSS Cabin Compartment Sensor Installation.

2. Position FSS cabin compartment sensor (Figure 2, Item 1) on right lower hinge pillar.
3. Install four screws (Figure 2, Item 3). Tighten screws securely.
4. Install electrical connector (Figure 2, Item 4) on FSS cabin compartment sensor (Figure 2, Item 1).

END OF TASK**FOLLOW-ON MAINTENANCE**

1. Install cabin roof moldings (WP 0583).
2. Enable FSS (WP 0736).
3. Remove wheel chocks (TM 9-2355-106-10).

END OF TASK**END OF WORK PACKAGE**

FIELD MAINTENANCE
FIRE SUPPRESSION SYSTEM (FSS) FUEL TANK CYLINDER REMOVAL AND INSTALLATION

INITIAL SETUP:**Tools and Special Tools**

General Mechanic's Tool Kit (GMTK)
(WP 0795, Item 37)

WP 0782

Equipment Condition

Parking brake set (TM-9-2355-106-10)

Transmission set in NEUTRAL (N)
(TM-9-2355-106-10)

Engine off (TM-9-2355-106-10)

MAIN POWER switch off (TM-9-2355-106-10)

Wheels chocked (TM-9-2355-106-10)

FSS disabled (WP 0736)

Materials/Parts

Grease (WP 0794, Item 22)

References

TM 9-2355-106-10

TM 9-2355-106-23P

WP 0786

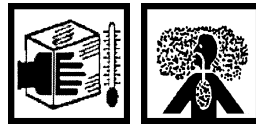
WARNING

Replace fire extinguisher immediately after use, even if only partly used. Failure to comply may result in serious injury or death to personnel.

Some fire suppression systems have a safety pin to install before disconnecting lines. Check to see if system uses a safety pin and install it before disconnecting lines. When disconnecting the extinguisher lines, use extreme caution. Do not disturb the pyrotechnic actuator and pressure switch; this will cause the extinguisher to discharge automatically. Failure to comply may result in damage to equipment and serious injury or death to personnel.

FSS extinguisher can move violently when discharging. Ensure extinguisher is properly secured during use. Failure to comply may result in damage to equipment and serious injury or death to personnel.

Before installing FSS extinguisher, verify correct part number is being installed. Check for visible damage to the canister, such as dents, cracked plastic, chips, or scratches where hoses connect. If damage is visible anywhere, do not use; contact your supervisor. Failure to comply may result in damage to equipment and serious injury or death to personnel.

Prior to servicing Fire Suppression System (FSS), make sure FSS power is off, and FSS is disabled. Failure to comply may result in discharging of system and serious injury or death to personnel.

FIRE SUPPRESSION SYSTEM (FSS) FUEL TANK CYLINDER REMOVAL AND INSTALLATION - (CONTINUED)

REMOVAL

NOTE

FSS fuel tank cylinder is located on left side of vehicle on frame rail.

1. Remove FSS chassis harness connector (Figure 1, Item 2) and hose (Figure 1, Item 1) from FSS fuel tank cylinder.

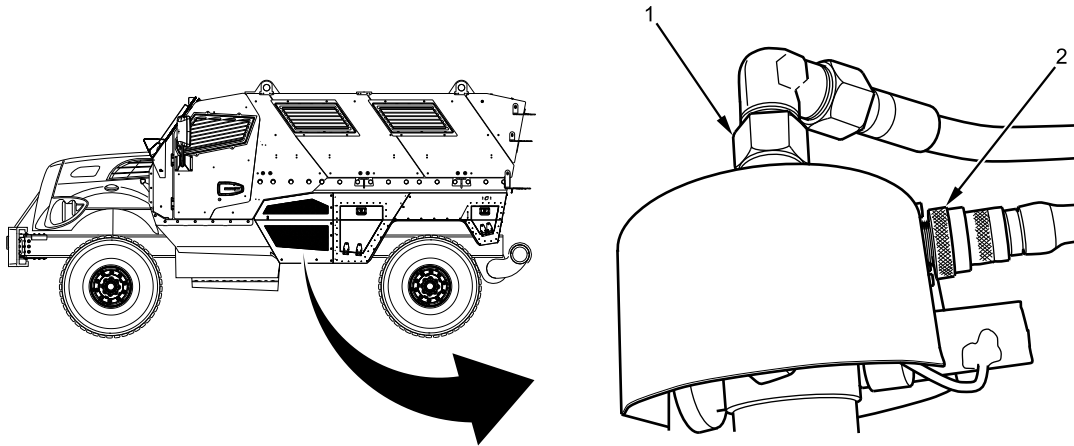

B230606060

Figure 1. FSS Fuel Tank Cylinder Connections.

2. Remove nuts and bolts (Figure 2, Item 1) from mounting strap bracket (Figure 2, Item 3) of FSS fuel tank cylinder (Figure 2, Item 2).
3. Remove FSS fuel tank cylinder (Figure 2, Item 2).

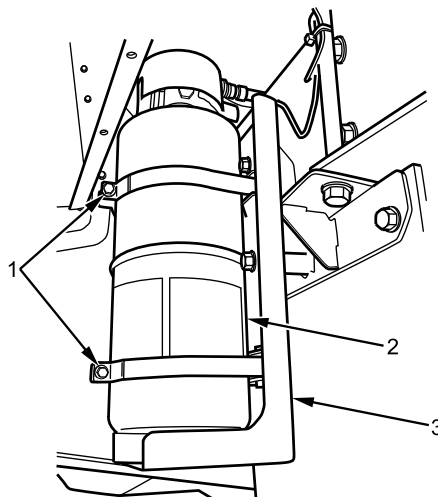

B230606047

Figure 2. FSS Engine Cylinder Mount.

END OF TASK

FIRE SUPPRESSION SYSTEM (FSS) FUEL TANK CYLINDER REMOVAL AND INSTALLATION - (CONTINUED)**INSTALLATION****WARNING**

Dielectric grease is harmful to skin and eyes. If grease contacts eyes, rinse thoroughly and contact physician if irritation persists. If skin is contacted, wash thoroughly with soap and water. Failure to comply may result in serious injury to personnel.

NOTE

Apply dielectric grease to all electrical connectors.

1. Position FSS fuel tank cylinder (Figure 3, Item 2) on mounting strap bracket (Figure 3, Item 3).
2. Install nuts and bolts (Figure 3, Item 1) on mounting strap bracket (Figure 3, Item 3) of FSS fuel tank cylinder (Figure 3, Item 2) and tighten securely.

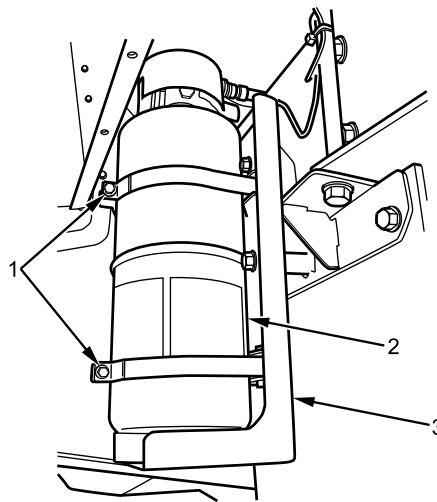

B230606047

Figure 3. FSS Fuel Tank Cylinder Mount.

FIRE SUPPRESSION SYSTEM (FSS) FUEL TANK CYLINDER REMOVAL AND INSTALLATION - (CONTINUED)

3. Install FSS chassis harness connector (Figure 4, Item 2) and hose (Figure 4, Item 1) on FSS fuel tank cylinder and tighten securely.

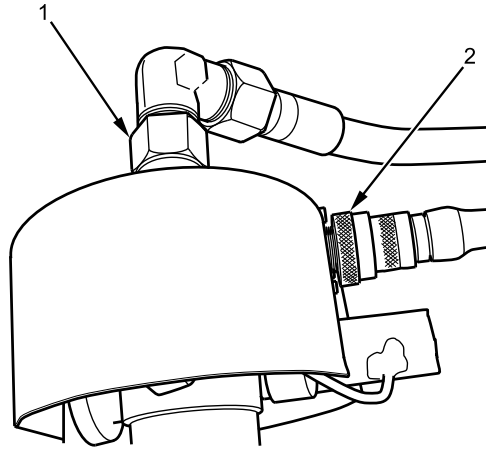

B237601611

Figure 4. FSS Fuel Tank Cylinder Connection.

END OF TASK**FOLLOW-ON MAINTENANCE**

1. Enable FSS (WP 0736).
2. Remove wheel chocks (TM-9-2355-106-10).

END OF TASK**END OF WORK PACKAGE**

FIELD MAINTENANCE

FIRE SUPPRESSION SYSTEM (FSS) FUEL TANK DISPERSION UNIT AND PIPE REMOVAL AND INSTALLATION

INITIAL SETUP:

Tools and Special Tools

General Mechanic's Tool Kit (GMTK)
(WP 0795, Item 37)

References

TM 9-2355-106-10
TM 9-2355-106-23P
WP 0782

Equipment Condition

Parking brake set (TM 9-2355-106-10)
Transmission set in NEUTRAL (N) (TM 9-2355-106-10)
Engine off (TM 9-2355-106-10)
MAIN POWER switch off (TM 9-2355-106-10)
Wheels chocked (TM 9-2355-106-10)
Belly armor removed (WP 0606)
FSS disabled (WP 0736)

WARNING

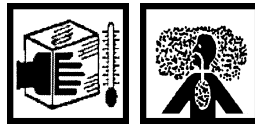

Prior to servicing Fire Suppression System (FSS), make sure FSS power is off, and FSS is disabled. Failure to comply may result in discharging of system and serious injury or death to personnel.

NOTE

The FSS fuel tank dispersion unit is located above fuel tank and inboard of frame rail.

The FSS fuel tank dispersion unit and pipe system consists of nozzles, fittings, pipes, and hoses that are connected to the FSS fuel tank cylinder. If system is being serviced due to damage, replace necessary components, noting their respective routing and locations for reference.

REMOVAL

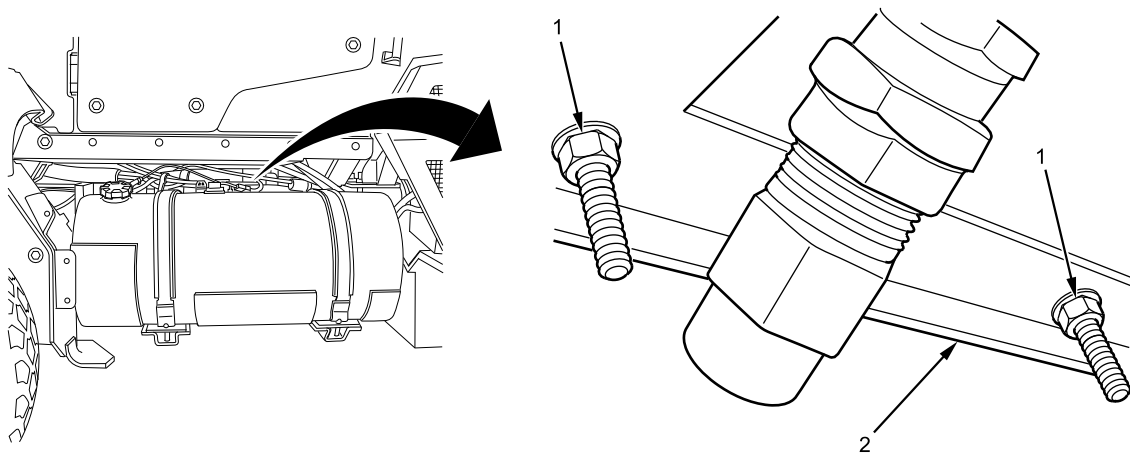

B230606043

Figure 1. Fuel Tank FSS Bracket.

1. Remove two nuts (Figure 1, Item 1) securing fuel tank FSS bracket (Figure 1, Item 2) to floor.

FIRE SUPPRESSION SYSTEM (FSS) FUEL TANK DISPERSION UNIT AND PIPE REMOVAL AND INSTALLATION - (CONTINUED)

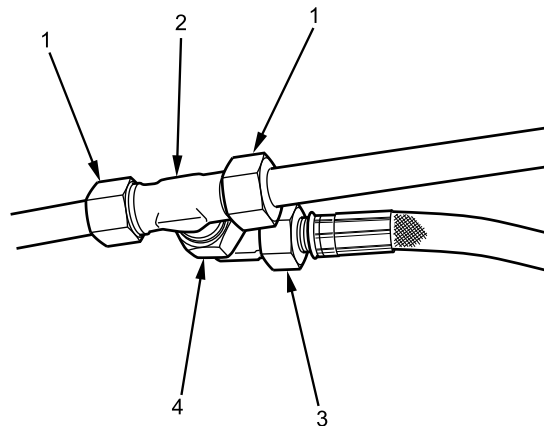

B237602045

Figure 2. FSS Fuel Tank Dispersion Unit Hose.

2. Remove nut (Figure 2, Item 3) from elbow (Figure 2, Item 4) and remove bracket from vehicle.
3. Remove nuts (Figure 2, Item 1) from T (Figure 2, Item 2) if pipes are being serviced.

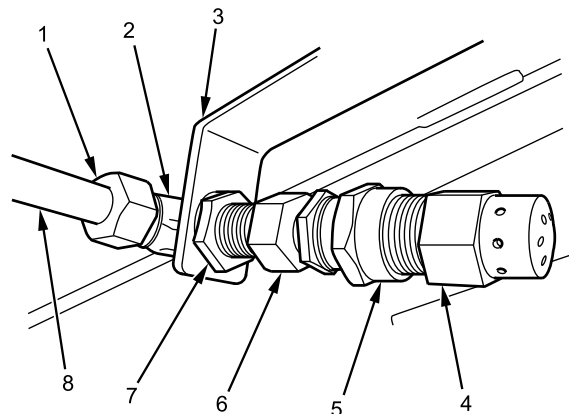

B237602044

Figure 3. FSS Fuel Tank Dispersion Unit and Pipe, (Rear Nozzle Shown, Front Nozzle Similar).

4. Hold fitting (Figure 3, Item 2) and remove adapter (Figure 3, Item 6) securing fittings (Figure 3, Item 5).
5. Separate nozzle (Figure 3, Item 4) from fitting if nozzle is being replaced.
6. Loosen nut (Figure 3, Item 1) and remove pipe (Figure 3, Item 8) from fitting (Figure 3, Item 2).
7. Remove nut (Figure 3, Item 7) securing fitting (Figure 3, Item 2) and remove from bracket (Figure 3, Item 3).

END OF TASK

FIRE SUPPRESSION SYSTEM (FSS) FUEL TANK DISPERSION UNIT AND PIPE REMOVAL AND INSTALLATION - (CONTINUED)

INSTALLATION

NOTE

Transfer parts as necessary if only a section of FSS fuel tank dispersion unit and pipe is being replaced.

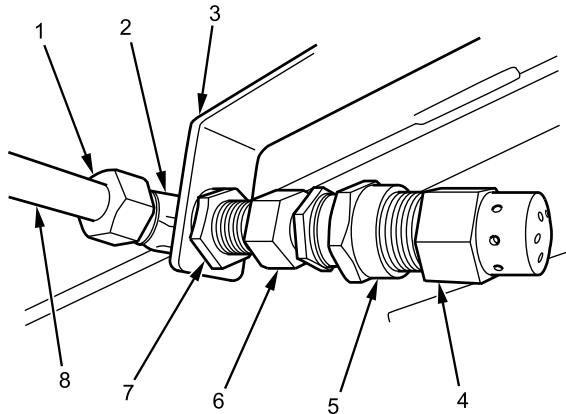

B237602044

Figure 4. FSS Fuel Tank Dispersion Unit and Pipe, (Rear Nozzle Shown, Front Nozzle Similar).

1. Position fitting (Figure 4, Item 2) on bracket (Figure 4, Item 3). Install nut (Figure 4, Item 7) and tighten securely.
2. Install pipe (Figure 4, Item 8) and nut (Figure 4, Item 1) on fitting (Figure 4, Item 2) and tighten securely.
3. Assemble nozzle (Figure 4, Item 4) on fitting (Figure 4, Item 5) if removed.
4. Install adapter (Figure 4, Item 6) on fitting (Figure 4, Item 2) and tighten securely.

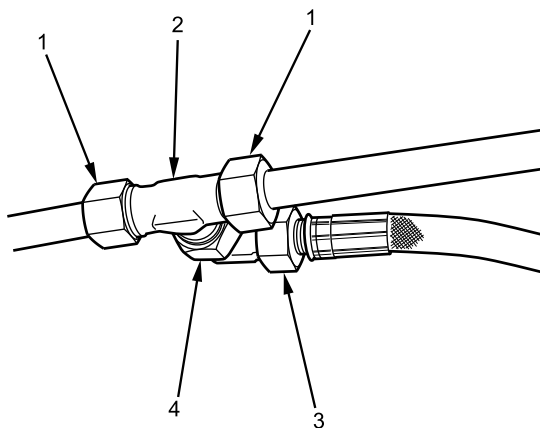

B237602045

Figure 5. FSS Fuel Tank Dispersion Unit Hose.

5. Install nut (Figure 5, Item 3) from hose to elbow (Figure 5, Item 4) and tighten securely.
6. Install nuts (Figure 5, Item 1) on T (Figure 5, Item 2) as necessary and tighten securely.

FIRE SUPPRESSION SYSTEM (FSS) FUEL TANK DISPERSION UNIT AND PIPE REMOVAL AND INSTALLATION - (CONTINUED)

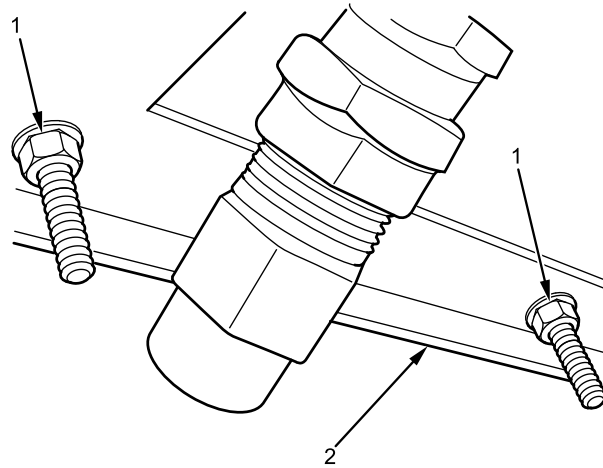

B237602887

Figure 6. Fuel Tank FSS Bracket.

WARNING



Antiseize compound can cause skin, eye, and respiratory irritation. Inhalation can cause difficulty breathing, dizziness, headache, and nausea. Wear eye protection and use only with adequate ventilation. Do not use near heat, sparks, or open flame. Wash hands and eyes after using compound. In case of skin contact, wash affected area with soap and water, and seek medical attention if irritation persists. If compound contacts eyes, flush eyes with water for at least 15 minutes, and obtain medical attention if irritation persists. In case of accidental ingestion, do not induce vomiting. Slowly drink 1-2 glasses of water or milk, and seek medical attention. Store compound in a closed container away from heat. Dispose of it in accordance with standard operating procedures. Failure to comply may result in injury to personnel.

7. Apply corrosion preventive compound to nozzle bracket assembly bolts (Figure 6, Item 1).
8. Position fuel tank FSS bracket (Figure 6, Item 2) to floor and install two nuts (Figure 6, Item 1) and tighten securely.

END OF TASK

FOLLOW-ON MAINTENANCE

1. Install belly armor (WP 0606).
2. Enable FSS (WP 0736).
3. Remove wheel chocks (TM-2355-106-10).

END OF TASK

END OF WORK PACKAGE

FIELD MAINTENANCE
FIRE SUPPRESSION SYSTEM (FSS) CABIN CYLINDER REMOVAL AND INSTALLATION

INITIAL SETUP:**Tools and Special Tools**

General Mechanic's Tool Kit (GMTK)
(WP 0795, Item 37)

WP 0782

Equipment Condition

Parking brake set (TM 9-2355-106-10)
Transmission set in NEUTRAL (N) (TM
9-2355-106-10)
Engine off (TM 9-2355-106-10)
MAIN POWER switch off (TM 9-2355-106-10)
Wheels chocked (TM 9-2355-106-10)
FSS disabled (WP 0736)

Materials/Parts

Grease (WP 0794, Item 22)

References

TM 9-2355-106-10
TM 9-2355-106-23P
WP 0786

WARNING

Replace fire extinguisher immediately after use, even if only partly used and confirm that replacement extinguisher is correct part number and chemical agent before installing. Failure to comply may result in serious injury or death to personnel.

Some fire suppression systems have a safety pin to install before disconnecting lines. Check to see if system uses a safety pin and install it before disconnecting lines. When disconnecting the extinguisher lines, use extreme caution. Do not disturb the pyrotechnic actuator and pressure switch; this will cause the extinguisher to discharge automatically. Failure to comply may result in damage to equipment and serious injury or death to personnel.

Fire Suppression System (FSS) extinguisher can move violently when discharging. Ensure extinguisher is properly secured during use. Failure to comply may result in damage to equipment and serious injury or death to personnel.

Before installing Fire Suppression System (FSS) extinguisher, verify correct part number is being installed. Check for visible damage to the canister, such as dents, cracked plastic, chips, or scratches where hoses connect. If damage is visible anywhere, do not use; contact your supervisor. Failure to comply may result in damage to equipment and serious injury or death to personnel.

Prior to servicing Fire Suppression System (FSS), make sure FSS power is off, and FSS is disabled. Failure to comply may result in discharging of system and serious injury or death to personnel.

FIRE SUPPRESSION SYSTEM (FSS) CABIN CYLINDER REMOVAL AND INSTALLATION - (CONTINUED)

REMOVAL

1. Remove connector (Figure 1, Item 2) from FSS control unit (Figure 1, Item 1) to disable FSS system.

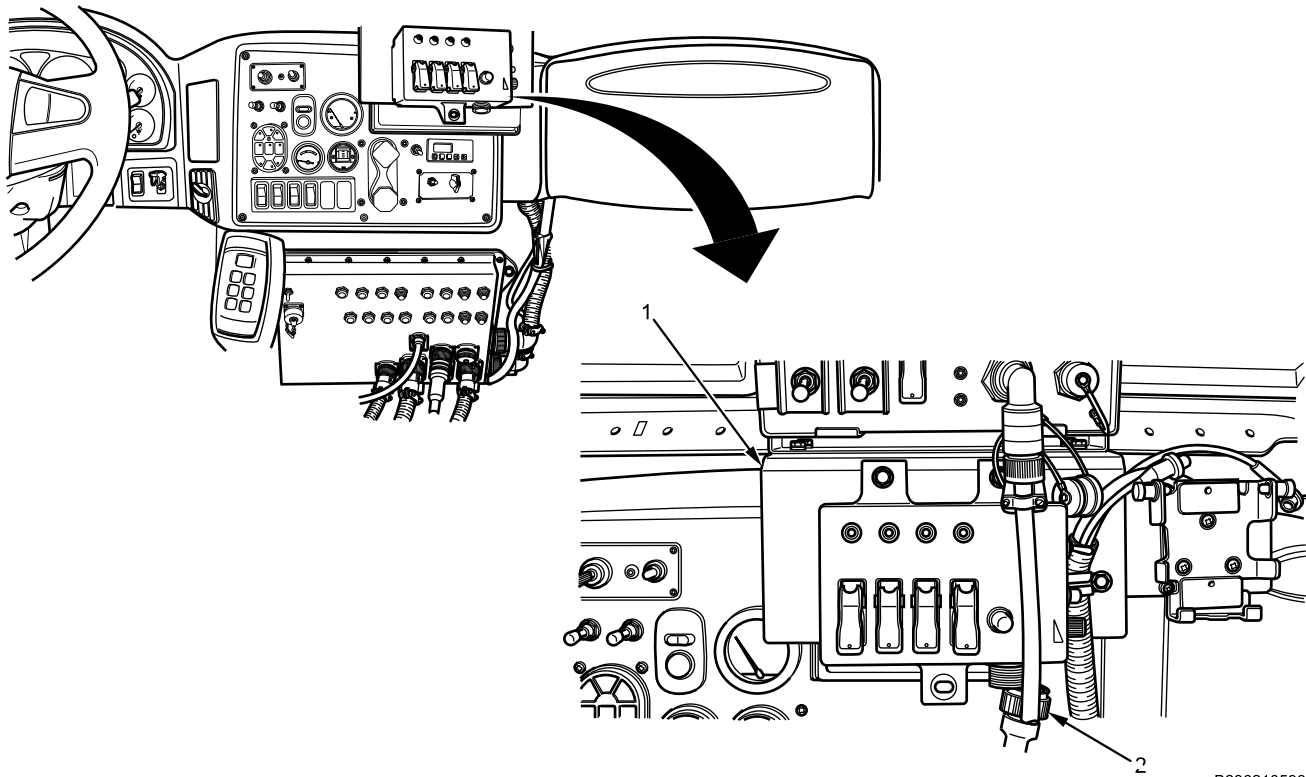

B236210598

Figure 1. FSS Control Unit.

2. Remove electrical connector (Figure 2, Item 1) from FSS cabin cylinder and guide through hole (Figure 2, Item 2) in shield.

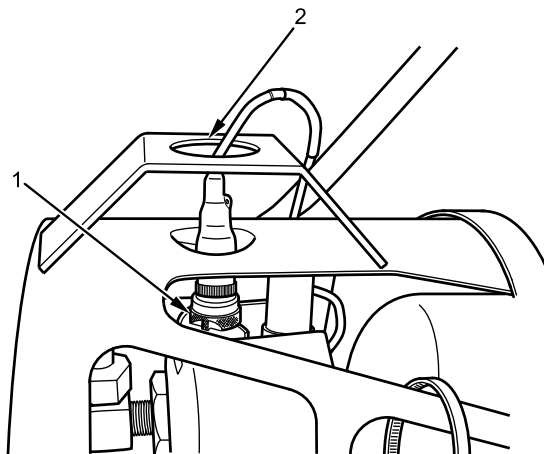

B237601614

Figure 2. FSS Cabin Cylinder Electrical Connector.

3. Loosen bolt (Figure 3, Item 3) on FSS cabin cylinder shield strap.

FIRE SUPPRESSION SYSTEM (FSS) CABIN CYLINDER REMOVAL AND INSTALLATION - (CONTINUED)

Figure 3. FSS Cabin Cylinder Connections Shield.

4. Remove cylinder shield (Figure 3, Item 4) from FSS cabin cylinder.
5. Remove nuts and bolts (Figure 3, Item 1 and 2) from FSS cabin cylinder mounting straps.
6. Hold cylinder fitting (Figure 4, Item 3) and remove hoses (Figure 4, Item 1 and 2) from FSS cabin cylinder.

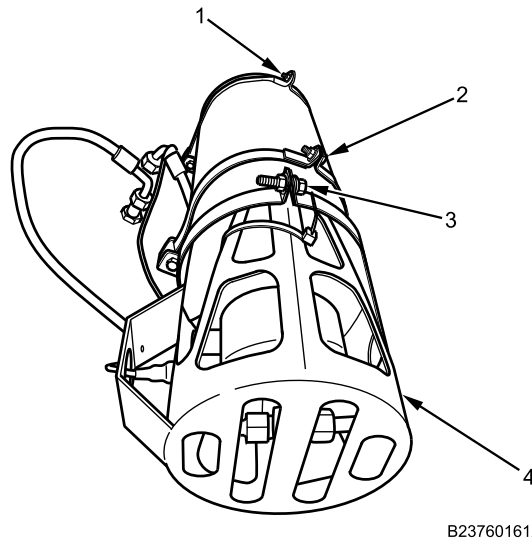
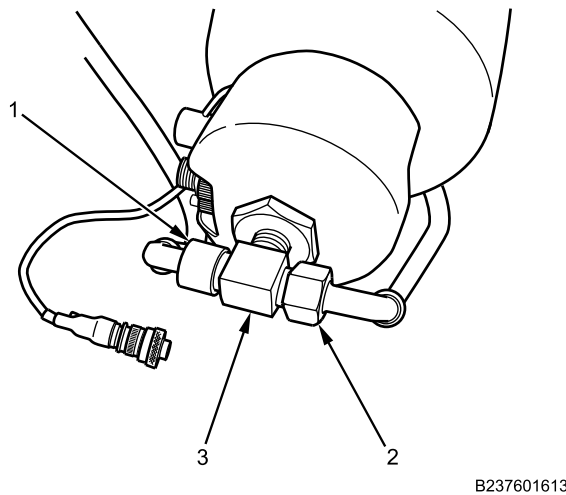

Figure 4. FSS Cabin Cylinder Hoses.

7. Remove FSS cabin cylinder.

END OF TASK

FIRE SUPPRESSION SYSTEM (FSS) CABIN CYLINDER REMOVAL AND INSTALLATION - (CONTINUED)**INSTALLATION****WARNING**

Dielectric grease is harmful to skin and eyes. If grease contacts eyes, rinse thoroughly and contact physician if irritation persists. If skin is contacted, wash thoroughly with soap and water. Failure to comply may result in serious injury to personnel.

NOTE

Apply dielectric grease to all electrical connectors.

1. Position FSS cabin cylinder on floor bracket.
2. Hold cylinder fitting (Figure 5, Item 3) and install hoses (Figure 5, Item 1 and 2) on FSS cabin cylinder. Do not tighten hoses at this time.

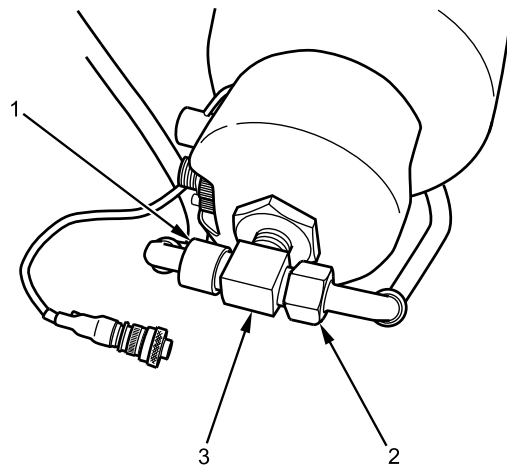

B237601613

Figure 5. FSS Cabin Cylinder Hoses.

3. Install nuts and bolts (Figure 6, Item 1 and 2) on FSS cabin cylinder mounting straps and tighten securely.

FIRE SUPPRESSION SYSTEM (FSS) CABIN CYLINDER REMOVAL AND INSTALLATION - (CONTINUED)

Figure 6. FSS Cabin Cylinder Connections Shield.

4. Install cylinder shield (Figure 6, Item 4) on FSS cabin cylinder.
5. Slide cylinder shield strap over cylinder shield and tighten bolt (Figure 6, Item 3) securely.
6. Tighten cylinder hose fittings (Figure 6, Item 1 and 2) securely.
7. Guide electrical connector (Figure 7, Item 1) through hole (Figure 7, Item 2) in shield and install connector on FSS cabin cylinder.

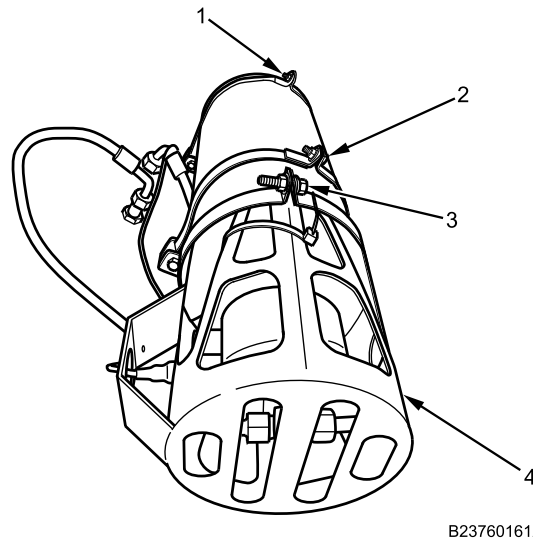
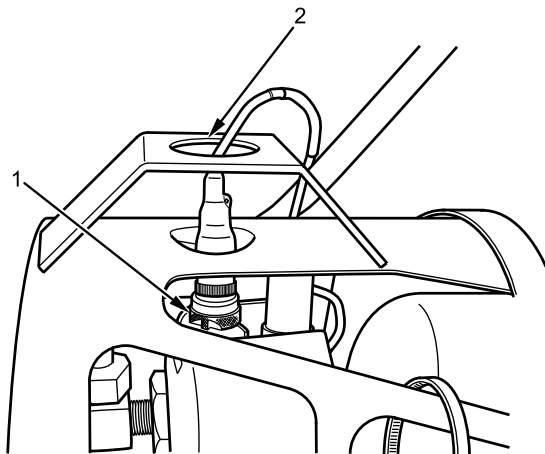
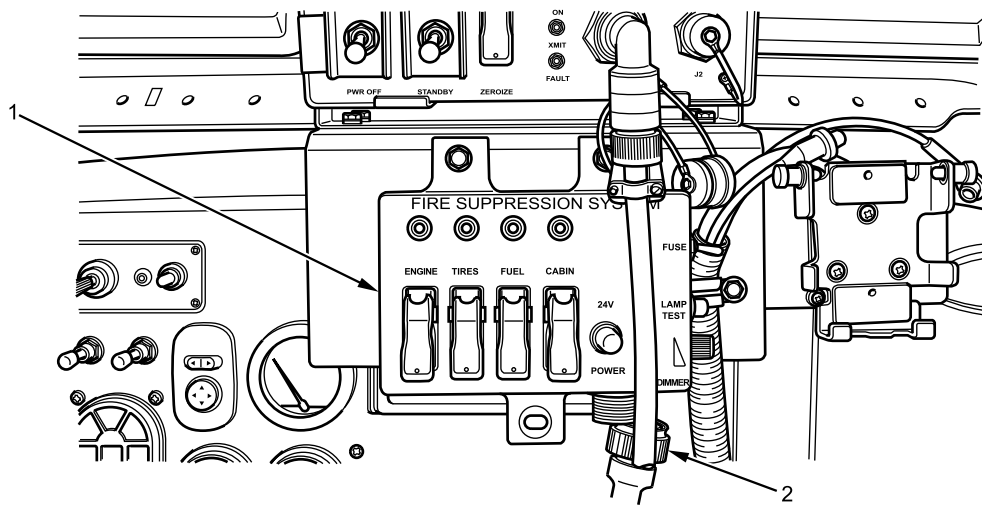

Figure 7. FSS Cabin Cylinder Electrical Connector.

FIRE SUPPRESSION SYSTEM (FSS) CABIN CYLINDER REMOVAL AND INSTALLATION - (CONTINUED)

8. Install connector (Figure 8, Item 2) on FSS control unit (Figure 8, Item 1).



B237601561

Figure 8. FSS Control Unit.

END OF TASK

FOLLOW-ON MAINTENANCE

1. Enable FSS (WP 0736).
2. Remove wheel chocks (TM 9-2355-106-10).

END OF TASK

END OF WORK PACKAGE

FIELD MAINTENANCE**FIRE SUPPRESSION SYSTEM (FSS) CABIN/CREW DISPERSION UNIT AND PIPE REMOVAL AND INSTALLATION**

INITIAL SETUP:**Tools and Special Tools**

General Mechanic's Tool Kit (GMTK)
(WP 0795, Item 37)

WP 0782

Materials/Parts

Cable lock strap (WP 0796, Item 120)

Equipment Condition

Parking brake set (TM-9-2355-106-10)

Transmission set in NEUTRAL (N)

(TM-9-2355-106-10)

Engine off (TM-9-2355-106-10)

MAIN POWER switch off (TM-9-2355-106-10)

Wheels chocked (TM-9-2355-106-10)

FSS disabled (WP 0736)

References

TM 9-2355-106-10

TM 9-2355-106-23P

WP 0786

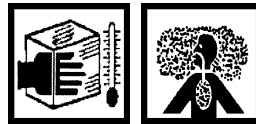
WARNING

Prior to servicing Fire Suppression System (FSS), make sure FSS power is off, and FSS is disabled. Failure to comply may result in discharging of system and serious injury or death to personnel.

NOTE

The FSS cabin/crew dispersion unit and pipe system consists of nozzles, fittings, pipes, and hoses that are connected to the FSS cabin/crew cylinder. If system is being serviced due to damage, replace necessary components, noting their respective routing and locations for reference.

FIRE SUPPRESSION SYSTEM (FSS) CABIN/CREW DISPERSION UNIT AND PIPE REMOVAL AND INSTALLATION - (CONTINUED)

REMOVAL

1. Hold fitting (Figure 1, Item 3) and remove adapter (Figure 1, Item 4) securing nozzle (Figure 1, Item 5). Separate nozzle from fitting if nozzle is being replaced.

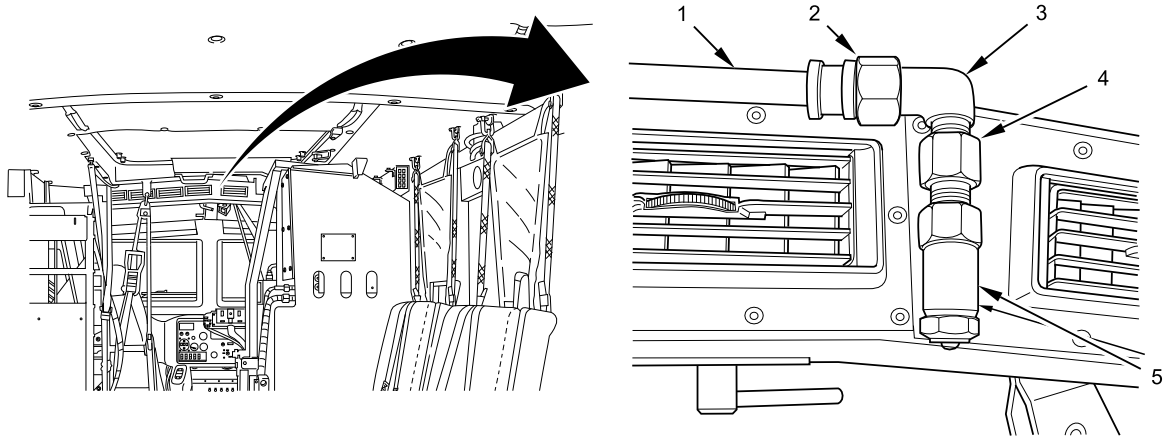

B230606042

Figure 1. Front FSS Cabin/Crew Dispersion Unit and Pipe.

2. Loosen nut (Figure 1, Item 2) and remove fitting (Figure 1, Item 3) from pipe (Figure 1, Item 1).
3. Loosen nut (Figure 2, Item 6) and remove from fitting (Figure 2, Item 5).

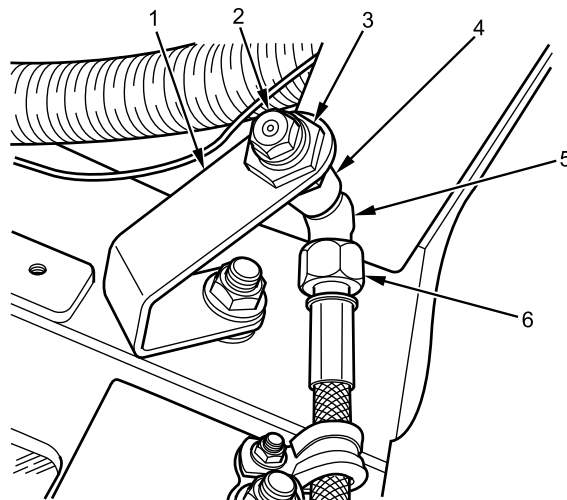

B237601973

Figure 2. Rear FSS Cabin/Crew Dispersion Unit and Pipe (Right Side Shown, Left Side Similar).

4. Remove nut (Figure 2, Item 3) securing fitting (Figure 2, Item 4) to bracket (Figure 2, Item 1).
5. Remove nozzle (Figure 2, Item 2) from fitting (Figure 2, Item 4) if nozzle is being replaced.

END OF TASK

FIRE SUPPRESSION SYSTEM (FSS) CABIN/CREW DISPERSION UNIT AND PIPE REMOVAL AND INSTALLATION - (CONTINUED)**INSTALLATION****NOTE**

Transfer parts as necessary if only a section of FSS cabin/crew dispersion unit and pipe is being replaced.

1. Install nozzle (Figure 3, Item 2) on fitting (Figure 3, Item 4) if removed and tighten securely.

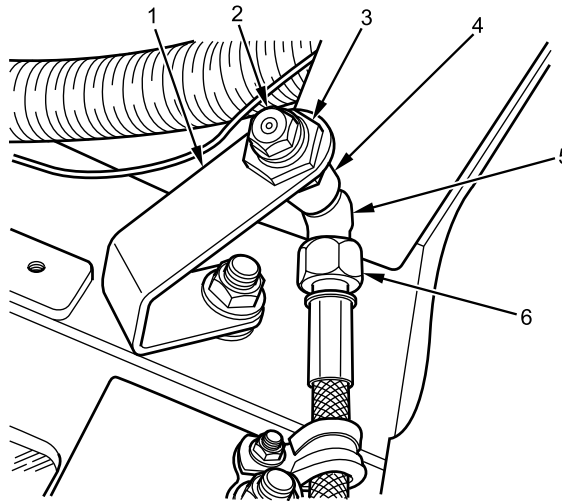

B237601973

Figure 3. Rear FSS Cabin/Crew Dispersion Unit and Pipe (Right Side Shown, Left Side Similar).

2. Position fitting (Figure 3, Item 4) on bracket (Figure 3, Item 1).
3. Install nut (Figure 3, Item 3) on fitting (Figure 3, Item 4) and tighten securely.
4. Install nut (Figure 3, Item 6) on fitting (Figure 3, Item 5) and tighten securely.

FIRE SUPPRESSION SYSTEM (FSS) CABIN/CREW DISPERSION UNIT AND PIPE REMOVAL AND INSTALLATION - (CONTINUED)

5. Install nozzle (Figure 4, Item 5) on adapter (Figure 4, Item 4) and tighten securely.

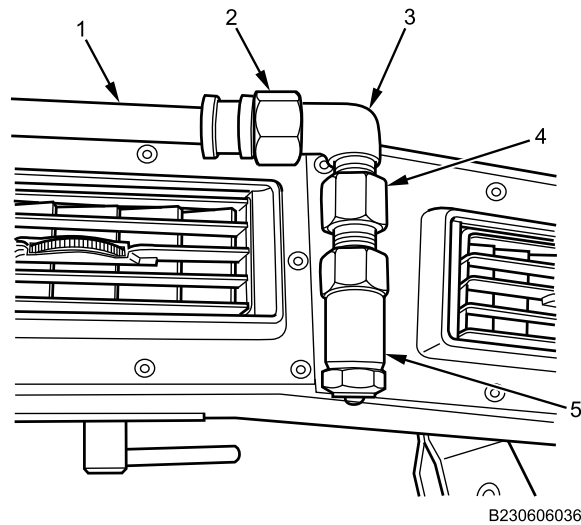

Figure 4. Front FSS Cabin/Crew Dispersion Unit and Pipe.

6. Install adapter (Figure 4, Item 4) on fitting (Figure 4, Item 3) and tighten securely.
7. Install pipe (Figure 4, Item 1) with nut (Figure 4, Item 2) on fitting (Figure 4, Item 3) and tighten securely.

END OF TASK**FOLLOW-ON MAINTENANCE**

1. Enable FSS (WP 0736).
2. Remove wheel chocks (TM-9-2355-106-10).

END OF TASK**END OF WORK PACKAGE**

FIELD MAINTENANCE
FIRE SUPPRESSION SYSTEM (FSS) TIRE CYLINDER REMOVAL AND INSTALLATION

INITIAL SETUP:**Tools and Special Tools**

General Mechanic's Tool Kit (GMTK)
(WP 0795, Item 37)

Materials/Parts

Grease (WP 0794, Item 22)

References

TM 9-2355-106-10
TM 9-2355-106-23P
WP 0782

Equipment Condition

Parking brake set (TM 9-2355-106-10)
Transmission set in NEUTRAL (N) (TM
9-2355-106-10)
Engine off (TM 9-2355-106-10)
MAIN POWER switch off (TM 9-2355-106-10)
Wheels chocked (TM 9-2355-106-10)
FSS disabled (WP 0736)
Left side rear stowage box removed (WP 0676)

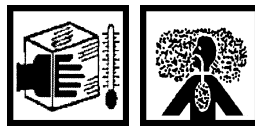
REMOVAL**WARNING**

Prior to servicing Fire Suppression System (FSS), make sure FSS power is off, master MAIN POWER switch is off, and FSS is disabled. Failure to comply may result in discharging of system and serious injury or death to personnel.

Replace fire extinguisher immediately after use, even if only partly used. Failure to comply may result in serious injury or death to personnel.

Some fire suppression systems have a safety pin to install before disconnecting lines. Check to see if system uses a safety pin and install it before disconnecting lines. When disconnecting the extinguisher lines, use extreme caution. Do not disturb the pyrotechnic actuator and pressure switch; this will cause the extinguisher to discharge automatically. Failure to comply may result in damage to equipment and serious injury or death to personnel.

FSS extinguisher can move violently when discharging. Ensure extinguisher is properly secured during use. Failure to comply may result in damage to equipment and serious injury or death to personnel.

Before installing FSS extinguisher, verify correct part number is being installed. Check for visible damage to the canister, such as dents, cracked plastic, chips, or scratches where hoses connect. If damage is visible anywhere, do not use; contact your supervisor. Failure to comply may result in damage to equipment and serious injury or death to personnel.

FIRE SUPPRESSION SYSTEM (FSS) TIRE CYLINDER REMOVAL AND INSTALLATION - (CONTINUED)

Figure 1. FSS Tire Cylinder Connections.

1. Remove electrical connector (Figure 1, Item 3) and hose (Figure 1, Item 4) from cylinder (Figure 1, Item 2).
2. Remove nuts and bolts (Figure 1, Item 1) from FSS tire cylinder mounting straps.
3. Remove FSS tire cylinder (Figure 1, Item 2).

END OF TASK

FIRE SUPPRESSION SYSTEM (FSS) TIRE CYLINDER REMOVAL AND INSTALLATION - (CONTINUED)**INSTALLATION****WARNING**

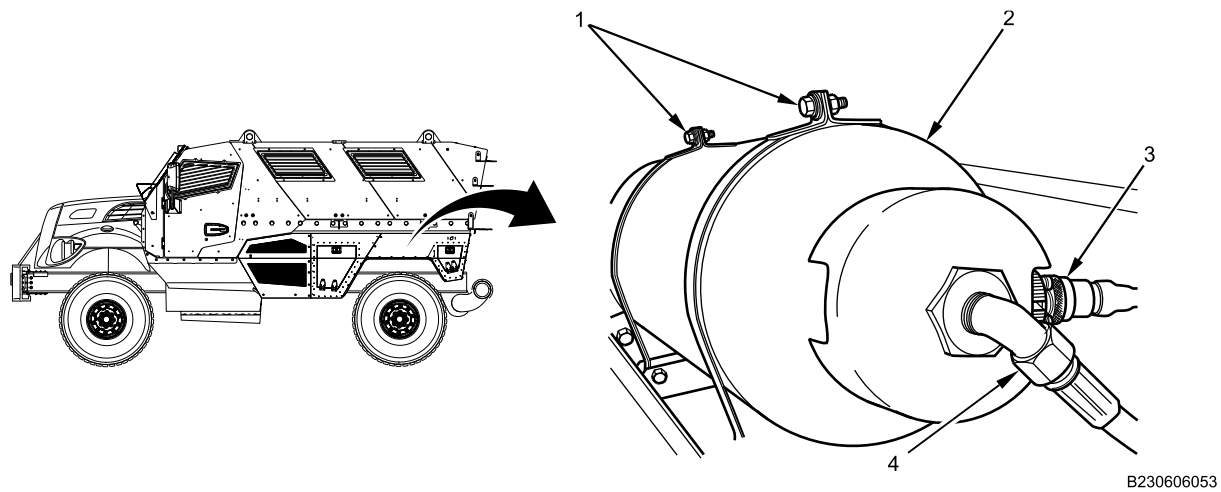
Dielectric grease is harmful to skin and eyes. If grease contacts eyes, rinse thoroughly and contact physician if irritation persists. If skin is contacted, wash thoroughly with soap and water. Failure to comply may result in serious injury to personnel.

NOTE

Apply dielectric grease to all electrical connectors.

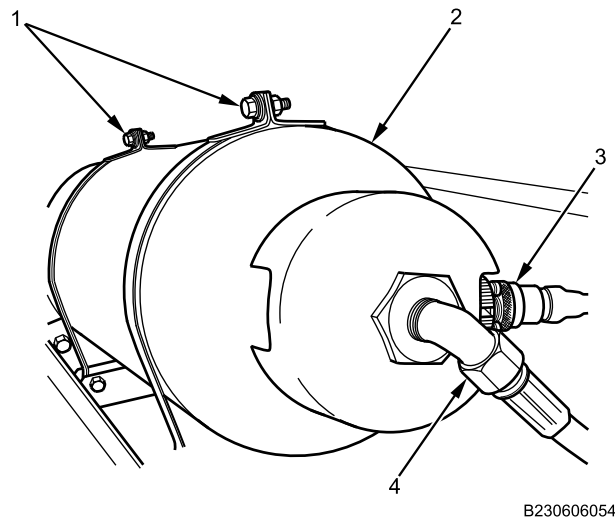

Figure 2. FSS Tire Cylinder Connections.

1. Install electrical connector (Figure 2, Item 3) and hose (Figure 2, Item 4) on cylinder (Figure 2, Item 2).
2. Position FSS tire cylinder on bracket.
3. Install nuts and bolts (Figure 2, Item 1) on FSS tire cylinder mounting straps and tighten securely.

END OF TASK**FOLLOW-ON MAINTENANCE**

1. Install left side rear stowage box (WP 0676).
2. Enable FSS (WP 0736).
3. Remove wheel chocks (TM-9-2355-106-10).

END OF TASK**END OF WORK PACKAGE**

FIELD MAINTENANCE
FIRE SUPPRESSION SYSTEM (FSS) FRONT TIRE DISPERSION UNIT AND PIPE REMOVAL AND INSTALLATION

INITIAL SETUP:**Tools and Special Tools**

General Mechanic's Tool Kit (GMTK)
(WP 0795, Item 37)

TM 9-2355-106-23P

WP 0782

Materials/Parts

Compound (WP 0794, Item 13)
Gloves (WP 0794, Item 18)
Faceshield, industrial (WP 0794, Item 16)

Equipment Condition

Parking brake set (TM 9-2355-106-10)
Transmission set in NEUTRAL (N) (TM 9-2355-106-10)
Engine off (TM 9-2355-106-10)
MAIN POWER switch off (TM 9-2355-106-10)
Wheels chocked (TM 9-2355-106-10)
FSS disabled (WP 0736)

References

TM 9-2355-106-10

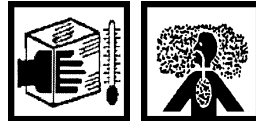
WARNING

Prior to servicing Fire Suppression System (FSS), make sure FSS power is off, and FSS is disabled. Failure to comply may result in discharging of system and serious injury or death to personnel.

NOTE

The FSS front tire dispersion unit and pipe system consists of nozzles, fittings, pipes, and hoses that are connected to the FSS tire cylinder. If system is being serviced due to damage, replace necessary components, noting their respective routing and locations for reference.

Right side shown, left side similar.

FIRE SUPPRESSION SYSTEM (FSS) FRONT TIRE DISPERSION UNIT AND PIPE REMOVAL AND INSTALLATION - (CONTINUED)

REMOVAL

1. Remove compression nut (Figure 1, Item 8) connecting pipe (Figure 1, Item 7) to hose (Figure 1, Item 9).

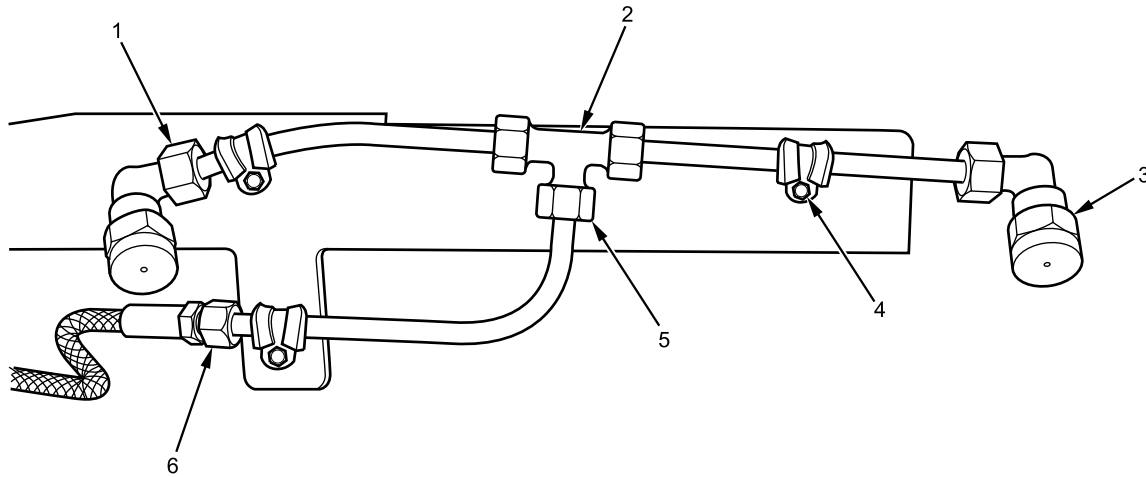

B237601972

Figure 1. FSS Front Tire Dispersion Unit and Pipe.

2. Remove three screws (Figure 1, Item 4) securing pipe assembly to bracket (Figure 1, Item 5).
3. Remove nozzle (Figure 1, Item 3) if nozzles are being replaced.
4. Remove pipe and elbows being serviced from T (Figure 1, Item 2) by loosening nuts (Figure 1, Item 1 and 6) if pipe is being replaced.

END OF TASK

INSTALLATION

WARNING



Corrosion preventive compound is toxic. Use only in well-ventilated area. Do not get in eyes; wear chemical safety goggles and full-face shield when using. Avoid contact with skin and wear rubber or plastic, solvent-resistant gloves. In case of contact, remove contaminated clothing and immediately wash area with soap and water. If compound contacts eyes, flush eyes with large amounts of water for at least 15 minutes and get immediate medical attention. If swallowed, do not induce vomiting; contact a physician immediately. Failure to comply may result in serious injury or death to personnel.

NOTE

Transfer parts as necessary if only a section of FSS front tire dispersion unit and pipe is being replaced.

1. Install pipe (Figure 2, Item 7) on T (Figure 2, Item 2) and tighten compression nut (Figure 2, Item 6) securely.

FIRE SUPPRESSION SYSTEM (FSS) FRONT TIRE DISPERSION UNIT AND PIPE REMOVAL AND INSTALLATION - (CONTINUED)

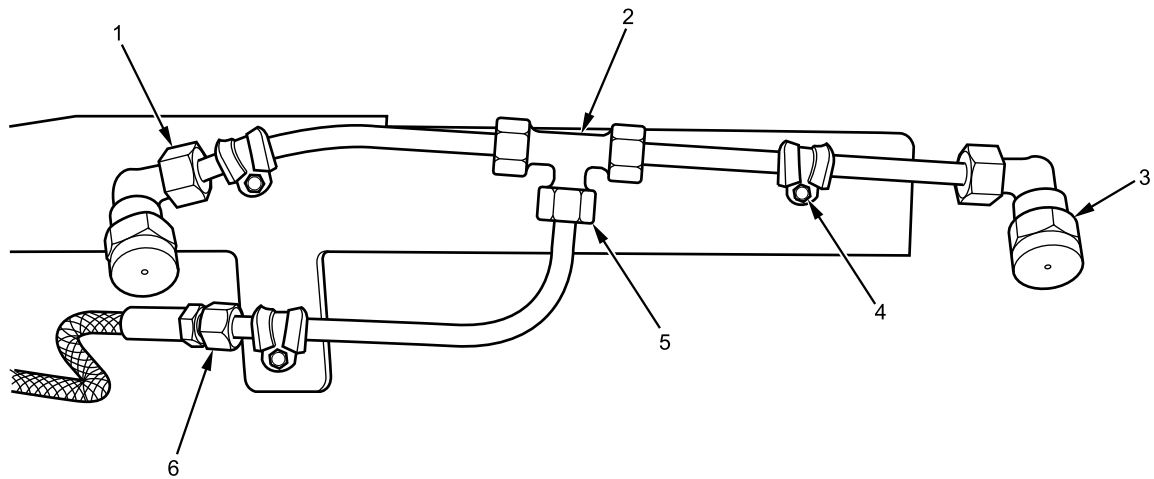

B237601972

Figure 2. FSS Front Tire Dispersion Unit and Pipe.

2. Install elbow (Figure 2, Item 1) on pipe and tighten securely.
3. Install nozzle (Figure 2, Item 3) on elbow (Figure 2, Item 1) and tighten securely.
4. Position pipe assembly on bracket (Figure 2, Item 5). Apply corrosion preventive compound to three screws (Figure 2, Item 4) and install. Tighten securely.
5. Install pipe (Figure 2, Item 7) on hose (Figure 2, Item 9) and tighten compression nut (Figure 2, Item 8) securely.

END OF TASK

FOLLOW-ON MAINTENANCE

1. Enable FSS (WP 0736).
2. Remove wheel chocks (TM-2355-106-10).

END OF TASK

END OF WORK PACKAGE

FIELD MAINTENANCE**FIRE SUPPRESSION SYSTEM (FSS) REAR TIRE DISPERSION UNIT AND PIPE REMOVAL AND INSTALLATION**

INITIAL SETUP:**Tools and Special Tools**

General Mechanic's Tool Kit (GMTK)
(WP 0795, Item 37)

References

TM 9-2355-106-10
TM 9-2355-106-23P
WP 0786
WP 0782

Equipment Condition

Parking brake set (TM 9-2355-106-10)
Transmission set in NEUTRAL (N) (TM 9-2355-106-10)
Engine off (TM 9-2355-106-10)
MAIN POWER switch off (TM 9-2355-106-10)
Wheels chocked (TM 9-2355-106-10)
FSS disabled (WP 0736)

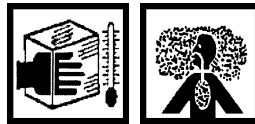
WARNING

Prior to servicing Fire Suppression System (FSS), make sure FSS power is off, and FSS is disabled. Failure to comply may result in discharging of system and serious injury or death to personnel.

NOTE

The FSS rear tire dispersion unit and pipe system consists of nozzles, fittings, pipes, and hoses that are connected to the FSS tire cylinder. If system is being serviced due to damage, replace necessary components, noting their respective routing and locations for reference.

Right side of FSS Rear Tire Dispersion Unit shown; left side similar.

FIRE SUPPRESSION SYSTEM (FSS) REAR TIRE DISPERSION UNIT AND PIPE REMOVAL AND INSTALLATION - (CONTINUED)

REMOVAL

1. Remove compression nut (Figure 1, Item 1) connecting pipe to hose.

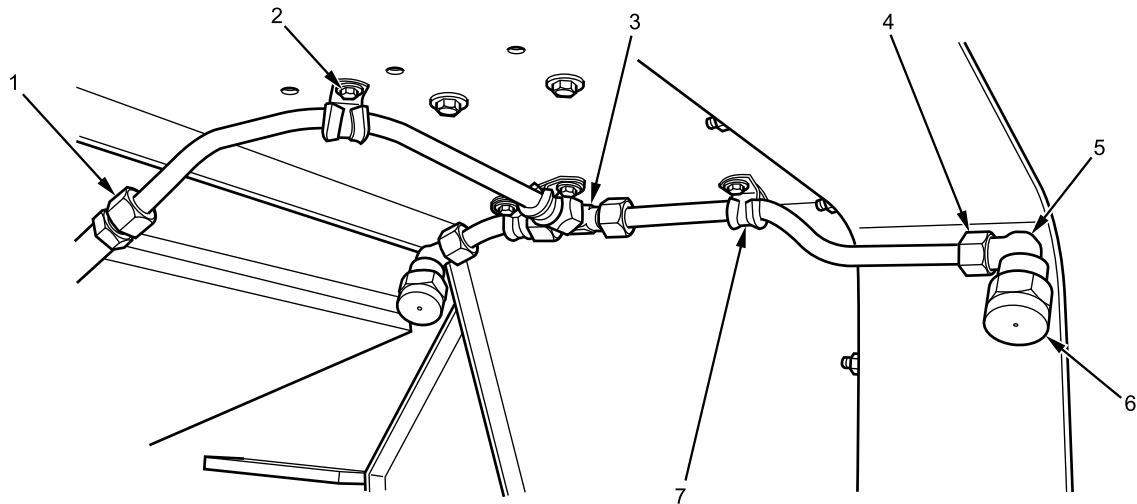

B237603217

Figure 1. FSS Rear Tire Dispersion Unit and Pipe.

2. Remove four bolts (Figure 1, Item 2) securing pipe clamps (Figure 1, Item 7) to wheel well.
3. Remove nozzle (Figure 1, Item 6) from elbow (Figure 1, Item 5) if nozzle is being serviced.
4. Remove elbow (Figure 1, Item 5) from pipe by loosening nut (Figure 1, Item 4).
5. Remove pipe being serviced from T-fitting (Figure 1, Item 3) if pipe is being replaced.

END OF TASK

INSTALLATION

NOTE

Transfer parts as necessary if only a section of FSS rear tire dispersion unit and pipe is being replaced.

1. Install pipes to T-fitting (Figure 2, Item 3) as necessary.

FIRE SUPPRESSION SYSTEM (FSS) REAR TIRE DISPERSION UNIT AND PIPE REMOVAL AND INSTALLATION - (CONTINUED)

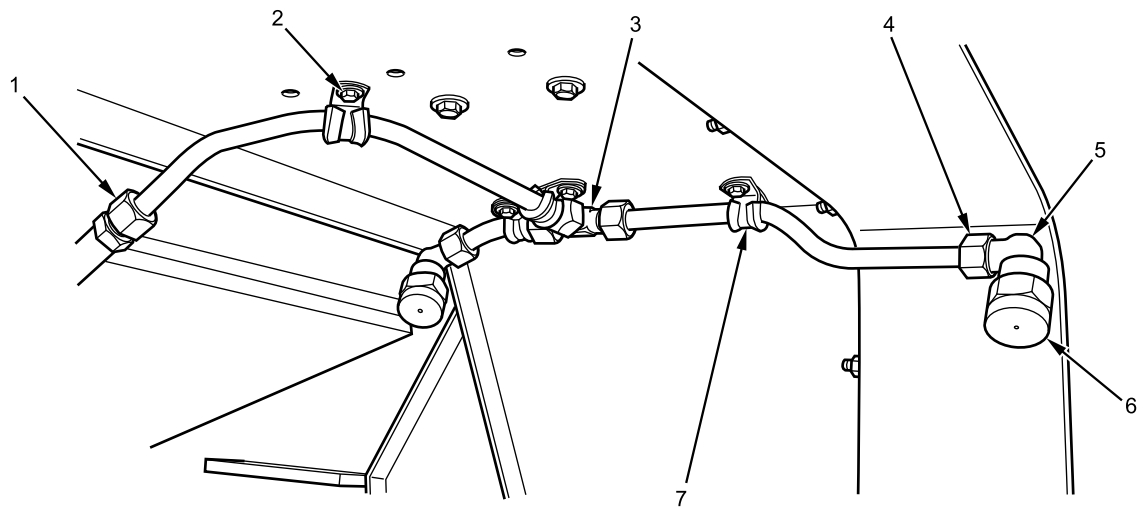

B237603217

Figure 2. FSS Rear Tire Dispersion Unit and Pipe.

2. Install pipe on hose and tighten compression nut (Figure 2, Item 1) securely.
3. Install elbow (Figure 2, Item 5) on pipe and tighten securely.
4. Install nozzle (Figure 2, Item 6) on elbow (Figure 2, Item 5).
5. Position pipe assembly on wheel well. Install four bolts (Figure 2, Item 2) and pipe clamps (Figure 2, Item 7). Tighten bolts securely.

END OF TASK

FOLLOW-ON MAINTENANCE

1. Enable FSS (WP 0736).
2. Remove wheel chocks (TM 9-2355-106-10).

END OF TASK

END OF WORK PACKAGE

FIELD MAINTENANCE
FIRE SUPPRESSION SYSTEM (FSS) ENGINE CYLINDER REMOVAL AND INSTALLATION

INITIAL SETUP:**Tools and Special Tools**

General Mechanic's Tool Kit (GMTK)
(WP 0795, Item 37)

WP 0782

Equipment Condition

Parking brake set (TM-9-2355-106-10)
Transmission set in NEUTRAL (N)
(TM-9-2355-106-10)
Engine off (TM-9-2355-106-10)
MAIN POWER switch off (TM-9-2355-106-10)
Wheels chocked (TM-9-2355-106-10)
FSS disabled (WP 0736)

Materials/Parts

Grease (WP 0794, Item 22)

References

TM 9-2355-106-10
TM 9-2355-106-23P
WP 0786

WARNING

Replace fire extinguisher immediately after use, even if only partly used. Failure to comply may result in serious injury or death to personnel.

Some fire suppression systems have a safety pin to install before disconnecting lines. Check to see if system uses a safety pin and install it before disconnecting lines. When disconnecting the extinguisher lines, use extreme caution. Do not disturb the pyrotechnic actuator and pressure switch; this will cause the extinguisher to discharge automatically. Failure to comply may result in damage to equipment and serious injury or death to personnel.

FSS extinguisher can move violently when discharging. Ensure extinguisher is properly secured during use. Failure to comply may result in damage to equipment and serious injury or death to personnel.

Before installing FSS extinguisher, verify correct part number is being installed. Check for visible damage to the canister, such as dents, cracked plastic, chips, or scratches where hoses connect. If damage is visible anywhere, do not use; contact your supervisor. Failure to comply may result in damage to equipment and serious injury or death to personnel.

Prior to servicing Fire Suppression System (FSS), make sure FSS power is off, and FSS is disabled. Failure to comply may result in discharging of system and serious injury or death to personnel.

FIRE SUPPRESSION SYSTEM (FSS) ENGINE CYLINDER REMOVAL AND INSTALLATION - (CONTINUED)**REMOVAL****NOTE**

FSS engine cylinder is located on right side of vehicle on frame rail.

1. Remove electrical connector (Figure 1, Item 2) and hose (Figure 1, Item 1) from cylinder.

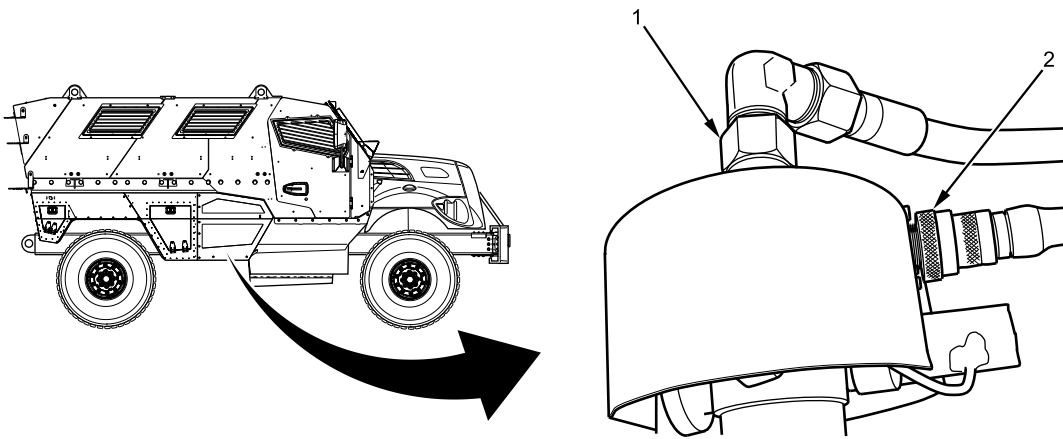

B230606059

Figure 1. FSS Engine Cylinder Connections.

2. Remove nuts and bolts (Figure 2, Item 1) from mounting strap bracket (Figure 2, Item 3) of FSS engine cylinder (Figure 2, Item 2).

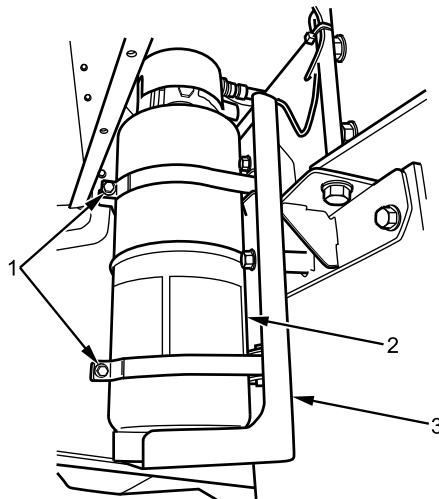

B230606047

Figure 2. FSS Engine Cylinder Mount.

3. Remove FSS engine cylinder (Figure 2, Item 2).

END OF TASK

FIRE SUPPRESSION SYSTEM (FSS) ENGINE CYLINDER REMOVAL AND INSTALLATION - (CONTINUED)**INSTALLATION****WARNING**

Dielectric grease is harmful to skin and eyes. If grease contacts eyes, rinse thoroughly and contact physician if irritation persists. If skin is contacted, wash thoroughly with soap and water. Failure to comply may result in serious injury to personnel.

NOTE

Apply dielectric grease to all electrical connectors.

1. Position FSS engine cylinder (Figure 3, Item 2) on mounting strap bracket (Figure 3, Item 3).

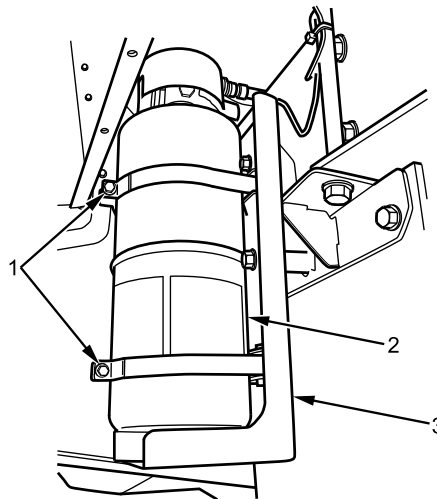

B230606047

Figure 3. FSS Engine Cylinder Mount.

2. Install nuts and bolts (Figure 3, Item 1) on mounting strap bracket (Figure 3, Item 3) of FSS engine cylinder (Figure 3, Item 2) and tighten securely.

FIRE SUPPRESSION SYSTEM (FSS) ENGINE CYLINDER REMOVAL AND INSTALLATION - (CONTINUED)

3. Install electrical connector (Figure 4, Item 2) and hose (Figure 4, Item 1) on cylinder and tighten securely.

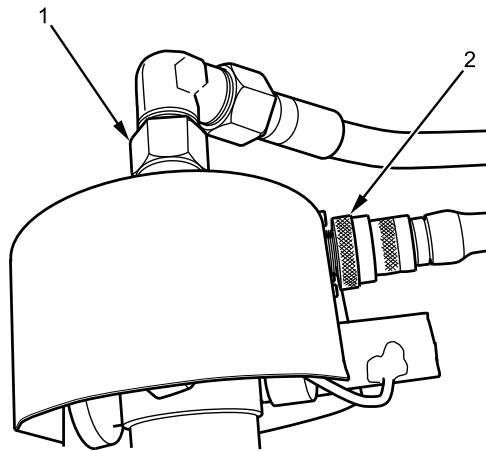

B237601611

Figure 4. FSS Engine Cylinder Connections.

END OF TASK**FOLLOW-ON MAINTENANCE**

1. Enable FSS (WP 0736).
2. Remove wheel chocks (TM-9-2355-106-10).

END OF TASK**END OF WORK PACKAGE**

FIELD MAINTENANCE
FIRE SUPPRESSION SYSTEM (FSS) ENGINE DISPERSION UNIT AND PIPE REMOVAL AND INSTALLATION

INITIAL SETUP:**Tools and Special Tools**

General Mechanic's Tool Kit (GMTK)
(WP 0795, Item 37)

WP 0782

Equipment Condition

Parking brake set (TM 9-2355-106-10)
Transmission set in NEUTRAL (N) (TM
9-2355-106-10)
Engine off (TM 9-2355-106-10)
MAIN POWER switch off (TM 9-2355-106-10)
Wheels chocked (TM 9-2355-106-10)
Engine hood open and secured (TM 9-2355-106-10)

Materials/Parts

Cable lock strap (WP 0796, Item 124)

References

TM 9-2355-106-10
TM 9-2355-106-23P
WP 0786

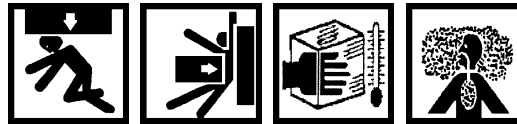
WARNING

Engine hood is extremely heavy and requires two-person lift. Ensure that there is adequate space in front of the vehicle to open hood completely without pinning or pinching personnel between hood and any other structure. Use extreme care when working under hood and make sure it is properly supported. Failure to comply may result in serious injury or death to personnel.

Prior to servicing Fire Suppression System (FSS), make sure FSS power is off, and FSS is disabled. Failure to comply may result in discharging of system and serious injury or death to personnel.

NOTE

The FSS engine dispersion unit and pipe system consists of nozzles, fittings, pipes, and hoses that are connected to the FSS engine cylinder. If system is being serviced due to damage, replace necessary components, noting their respective routing and locations for reference.

Note cable lock strap locations during removal for installation.

FIRE SUPPRESSION SYSTEM (FSS) ENGINE DISPERSION UNIT AND PIPE REMOVAL AND INSTALLATION - (CONTINUED)

REMOVAL

NOTE

Left side shown; right side similar.

1. Hold fitting (Figure 1, Item 4) and loosen nut (Figure 1, Item 5) securing nozzle (Figure 1, Item 6).

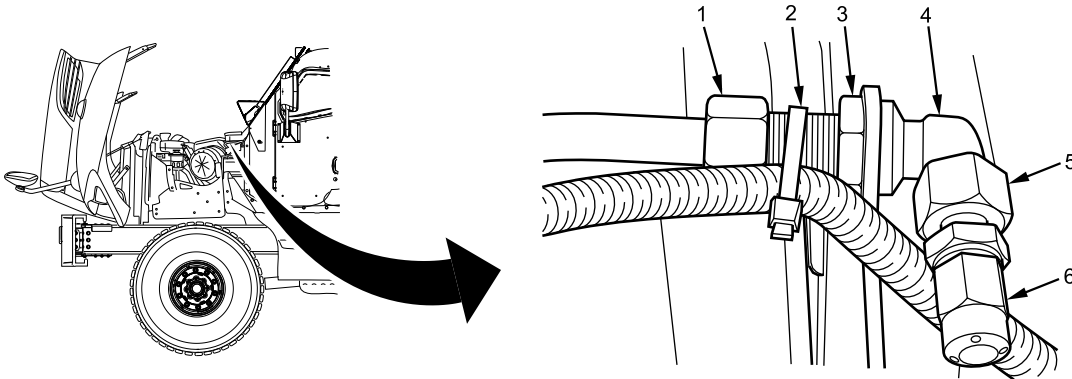

B237610593

Figure 1. FSS Engine Dispersion Unit and Pipe.

2. Cut and discard cable lock strap (Figure 1, Item 2).
3. Loosen nut (Figure 1, Item 1) securing pipe to fitting (Figure 1, Item 4).
4. Remove nut (Figure 1, Item 3) and remove fitting (Figure 1, Item 4).

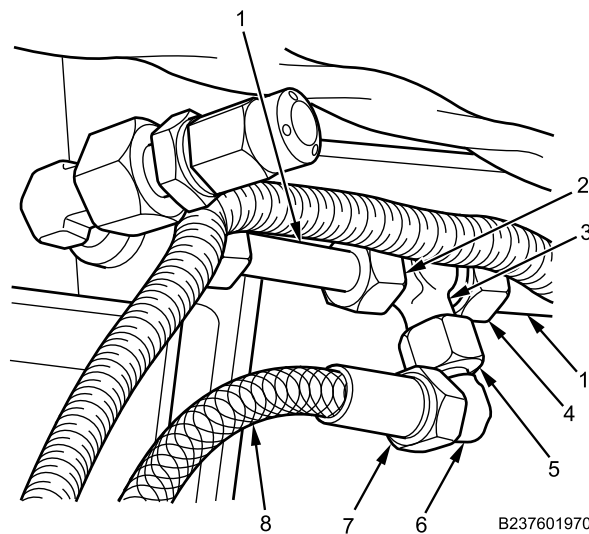

B237601970

Figure 2. FSS Engine Dispersion Unit and Pipe.

5. Remove hose (Figure 2, Item 8) from fitting (Figure 2, Item 6) by loosening nut (Figure 2, Item 7).
6. Remove pipes (Figure 2, Item 1) from T (Figure 2, Item 3) by loosening nuts (Figure 2, Item 2 and 4).
7. Remove fitting (Figure 2, Item 6) from T (Figure 2, Item 3) by loosening nut (Figure 2, Item 5).

END OF TASK

**FIRE SUPPRESSION SYSTEM (FSS) ENGINE DISPERSION UNIT AND PIPE REMOVAL AND INSTALLATION
- (CONTINUED)****INSTALLATION****NOTE**

Transfer parts as necessary if only a section of FSS engine dispersion unit and pipe is being replaced.

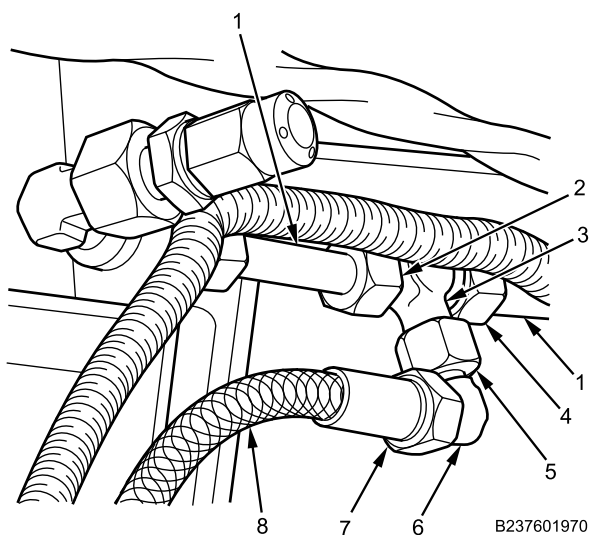

Figure 3. FSS Engine Dispersion Unit and Pipe.

1. Install fitting (Figure 3, Item 6) on T (Figure 3, Item 3) with nut (Figure 3, Item 5). Tighten securely.
2. Install pipes (Figure 3, Item 1) on T (Figure 3, Item 3) with nuts (Figure 3, Item 2 and 4). Tighten securely.
3. Install hose (Figure 3, Item 8) on fitting (Figure 3, Item 6) with nut (Figure 3, Item 7).

**FIRE SUPPRESSION SYSTEM (FSS) ENGINE DISPERSION UNIT AND PIPE REMOVAL AND INSTALLATION
- (CONTINUED)****NOTE**

Left side shown; right side similar.

4. Position fitting (Figure 4, Item 4) on bracket. Install nut (Figure 4, Item 3) and tighten securely.

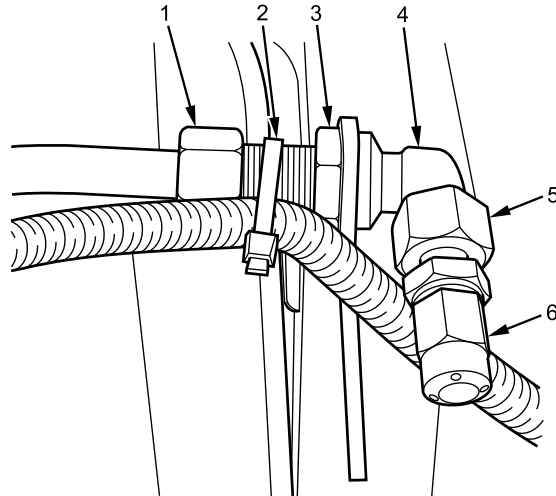

B237601971

Figure 4. FSS Engine Dispersion Unit and Pipe.

5. Hold fitting (Figure 4, Item 4) and install nut (Figure 4, Item 5) securing nozzle (Figure 4, Item 6) and tighten securely.
6. Install nut (Figure 4, Item 1) on fitting (Figure 4, Item 4) and tighten securely.
7. Install new cable lock strap (Figure 4, Item 2).

END OF TASK**FOLLOW-ON MAINTENANCE**

1. Close and secure engine hood (TM 9-2355-106-10).
2. Remove wheel chocks (TM 9-2355-106-10).

END OF TASK**END OF WORK PACKAGE**

FIELD MAINTENANCE

HEATING VENTILATING AND AIR CONDITIONING (HVAC)/LIFE SUPPORT SYSTEM (LSS) MAIN AIR DUCT
REMOVAL AND INSTALLATION

INITIAL SETUP:

Tools and Special Tools

General Mechanic's Tool Kit (GMTK)
(WP 0795, Item 37)

Materials/Parts

Cable lock strap (WP 0796, Item 120)

Personnel Required

Maintainer - (2)

References

TM 9-2355-106-10
TM 9-2355-106-23P
WP 0786

WP 0782

Equipment Condition

Parking brake set (TM 9-2355-106-10)
Transmission set in NEUTRAL (N) (TM
9-2355-106-10)
Engine off (TM 9-2355-106-10)
MAIN POWER switch off (TM 9-2355-106-10)
Wheels chocked (TM 9-2355-106-10)
Communications rack removed (WP 0667)
HVAC/LSS defogging air duct removed (WP 0754)
HVAC fresh air inlet tube removed (WP 0720)
HVAC/LSS air duct louvers removed (WP 0753)

REMOVAL

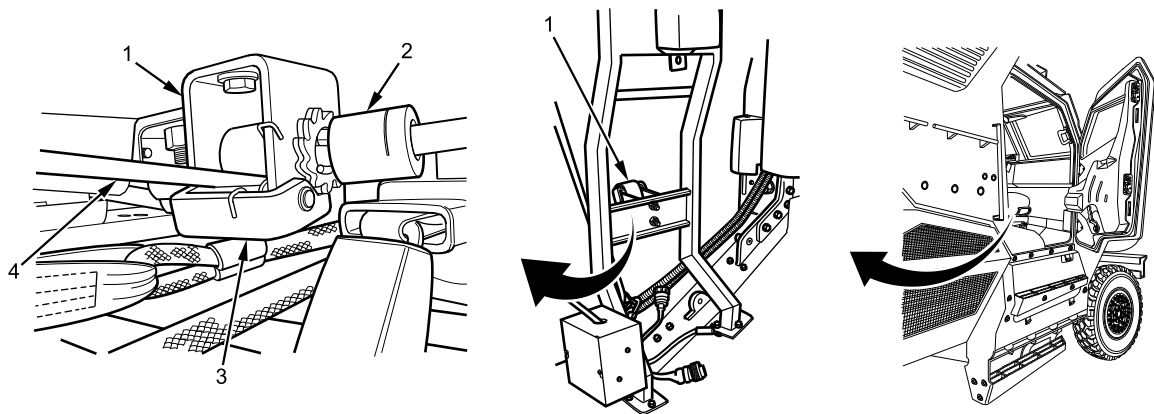

B239110606

Figure 1. Rear Seat Ratchet.

NOTE

Perform steps 1 through 3 for driver and passenger seats.

1. Release tension on driver and passenger rear seat hanger safety strap (Figure 1, Item 4) by turning nut with socket (Figure 1, Item 2) on ratchet assembly (Figure 1, Item 1). Hold release latch (Figure 1, Item 3) while loosening strap (Figure 1, Item 4).

HEATING VENTILATING AND AIR CONDITIONING (HVAC)/LIFE SUPPORT SYSTEM (LSS) MAIN AIR DUCT REMOVAL AND INSTALLATION - (CONTINUED)

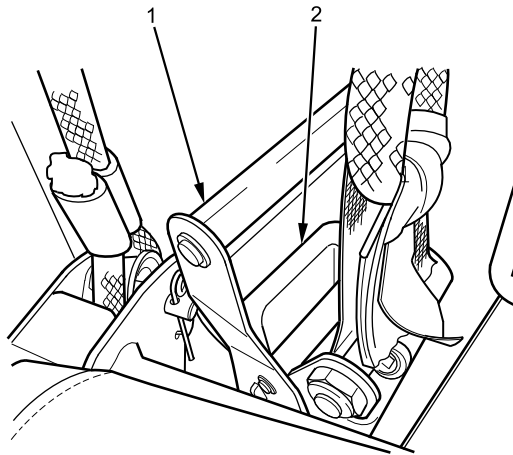

B230601679

Figure 2. Seat Suspension Lever Position.

2. Place hand on lever (Figure 2, Item 1), lift up on latch (Figure 2, Item 2), and swing handle down.

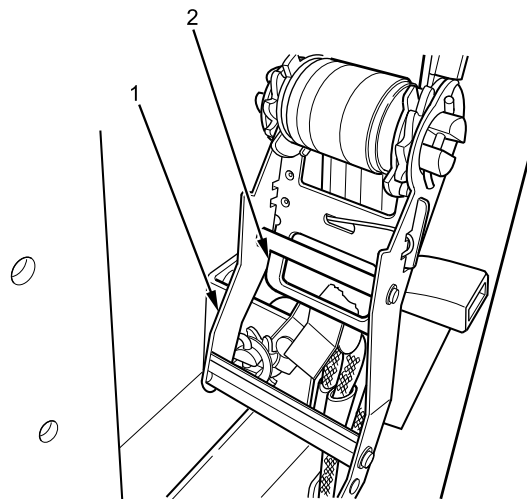

B230601682

Figure 3. Seat Suspension Lever Release.

3. With handle (Figure 3, Item 1) in down position, pull down on release lever (Figure 3, Item 2) to release tension on seat suspension.
4. Disconnect fire suppression line fitting (Figure 4, Item 2) located above left front seat.

**HEATING VENTILATING AND AIR CONDITIONING (HVAC)/LIFE SUPPORT SYSTEM (LSS) MAIN AIR DUCT
REMOVAL AND INSTALLATION - (CONTINUED)**

Figure 4. Fire Suppression Fitting.

5. Remove four suspension seat upper pulley block shackle bolts (Figure 4, Item 1) and shackles (Figure 4, Item 3).

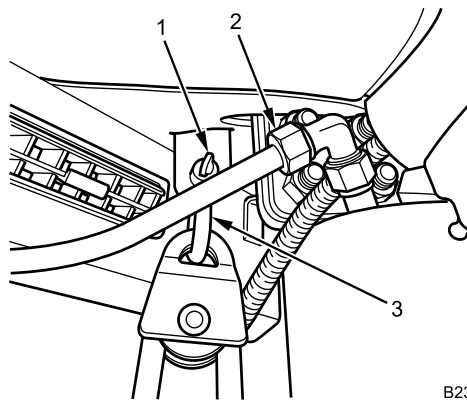
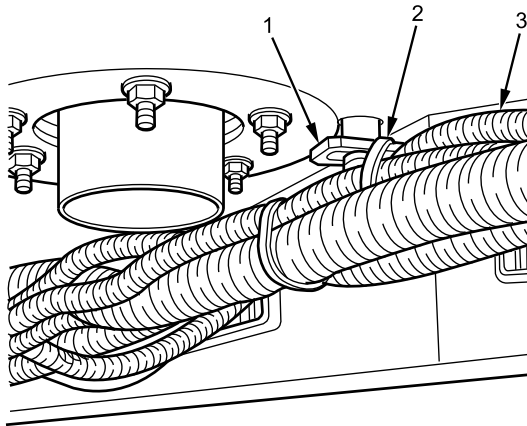
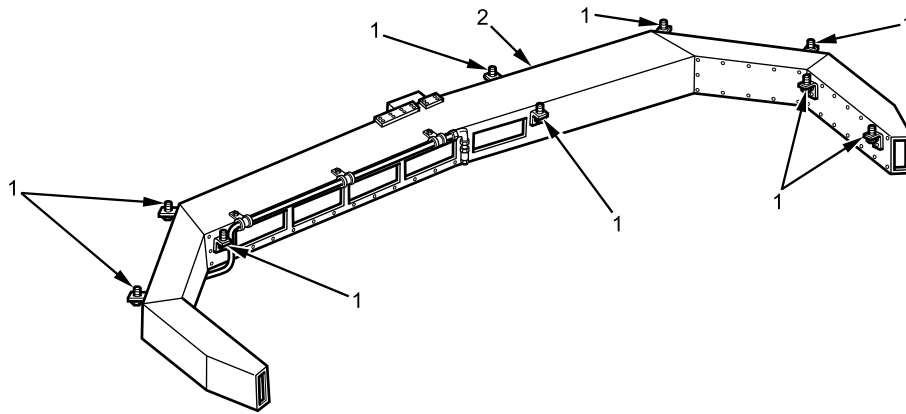

Figure 5. Wire Harness Cable Lock Strap.

6. Cut cable lock strap (Figure 5, Item 2) from main air duct (Figure 5, Item 1) and wire harness (Figure 5, Item 3). Discard cable lock strap.

HEATING VENTILATING AND AIR CONDITIONING (HVAC)/LIFE SUPPORT SYSTEM (LSS) MAIN AIR DUCT REMOVAL AND INSTALLATION - (CONTINUED)

- Remove nine bolts (Figure 6, Item 1) and flat washers from main air duct (Figure 6, Item 2).



B239110611

Figure 6. Main Air Duct Removal.

- Remove main air duct (Figure 6, Item 2) from roof headliner.

END OF TASK

DISASSEMBLY

NOTE

Note position and orientation of fire suppression line prior to removal to aid in installation.

- Remove three bolts (Figure 6, Item 2) from fire suppression line (Figure 6, Item 1).
- Remove fire suppression line (Figure 6, Item 1) from main air duct (Figure 6, Item 3).

END OF TASK

ASSEMBLY

- Position and orientate fire suppression line (Figure 6, Item 1) on main air duct (Figure 6, Item 3) as noted during removal.
- Install three bolts (Figure 6, Item 2) on fire suppression line (Figure 6, Item 1). Tighten bolts securely.

END OF TASK

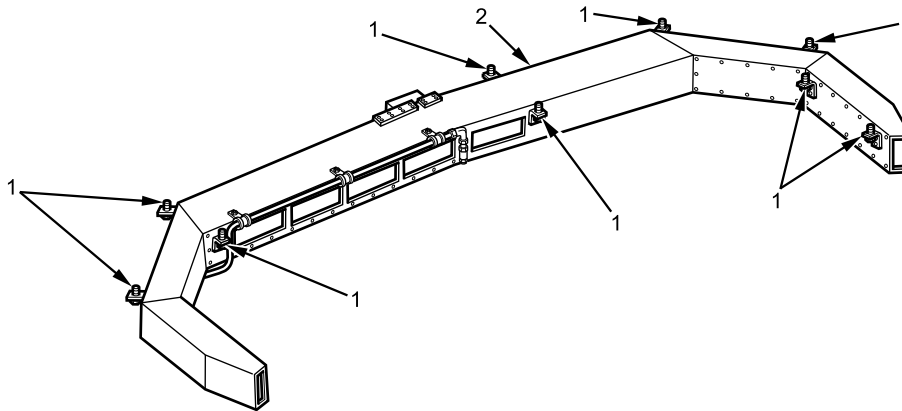
**HEATING VENTILATING AND AIR CONDITIONING (HVAC)/LIFE SUPPORT SYSTEM (LSS) MAIN AIR DUCT
REMOVAL AND INSTALLATION - (CONTINUED)****INSTALLATION**

B239110611

Figure 7. Main Air Duct Installation.

1. Install main air duct (Figure 7, Item 2) on roof headliner with nine bolts (Figure 7, Item 1) and flat washers. Tighten bolts securely.

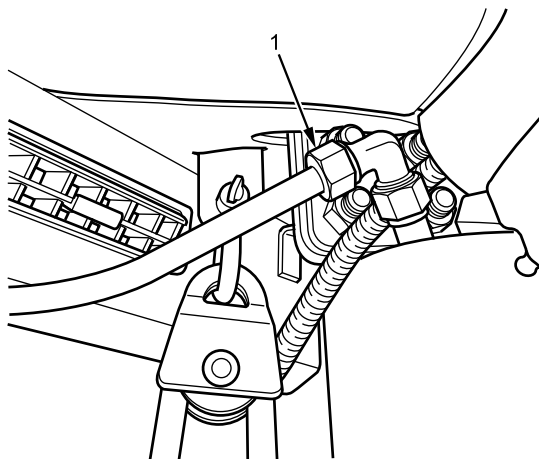

B239101961

Figure 8. Fire Suppression Fitting.

2. Connect fire suppression line fitting (Figure 8, Item 1) above left front seat. Tighten fitting securely.

HEATING VENTILATING AND AIR CONDITIONING (HVAC)/LIFE SUPPORT SYSTEM (LSS) MAIN AIR DUCT REMOVAL AND INSTALLATION - (CONTINUED)

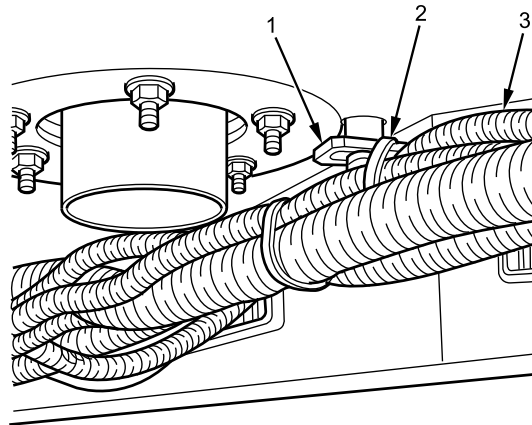

B239101962

Figure 9. Wire Harness Cable Lock Strap.

3. Install wire harness (Figure 9, Item 3) on main air duct (Figure 9, Item 1) with new cable lock strap (Figure 9, Item 2). Tighten cable lock strap securely.
4. Install four suspension seat upper pulley block shackles (Figure 10, Item 2) to upper pulley blocks (Figure 10, Item 3).

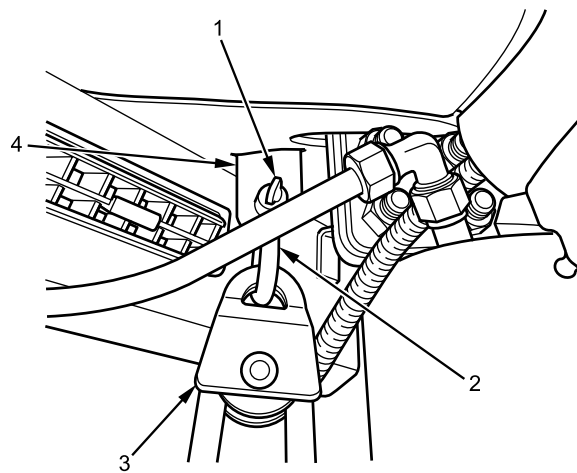

B239103265

Figure 10. Suspension Seat Shackles.

5. Position pulley block shackles (Figure 10, Item 2) to roof brackets (Figure 10, Item 4) and install shackle bolts (Figure 10, Item 1). Tighten shackle bolts securely.

HEATING VENTILATING AND AIR CONDITIONING (HVAC)/LIFE SUPPORT SYSTEM (LSS) MAIN AIR DUCT REMOVAL AND INSTALLATION - (CONTINUED)

NOTE

Perform steps 6 through 9 for driver and passenger seats.

6. Ensure handle (Figure 11, Item 1) is in down position and pull up on strap to remove slack.

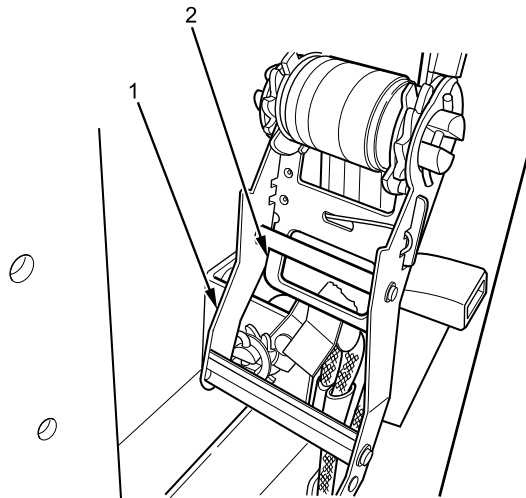

B230601682

Figure 11. Seat Suspension Lever Position.

7. Pull down on release latch (Figure 11, Item 2) and lift up on handle (Figure 11, Item 1) to begin ratcheting seat suspension handle until rope is tight.

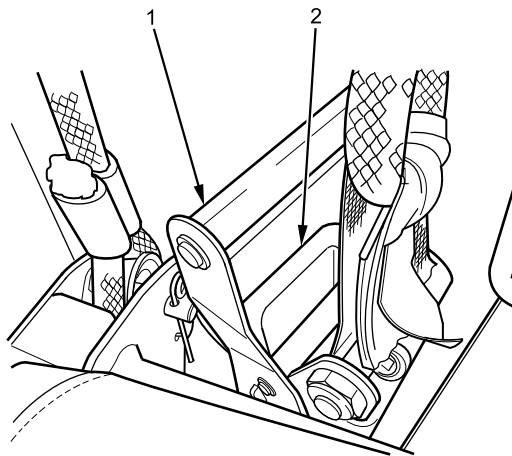

B230601679

Figure 12. Seat Suspension Lever Engaged.

8. Place handle (Figure 12, Item 1) in up position when rope is tightened and ensure latch (Figure 12, Item 2) is engaged in down position.

**HEATING VENTILATING AND AIR CONDITIONING (HVAC)/LIFE SUPPORT SYSTEM (LSS) MAIN AIR DUCT
REMOVAL AND INSTALLATION - (CONTINUED)**

Figure 13. Rear Seat Ratchet.

9. Turn seat ratchet (Figure 13, Item 2) until tight. Ensure latch (Figure 13, Item 1) is engaged.

END OF TASK**FOLLOW-ON MAINTENANCE**

1. Install HVAC/LSS air duct louvers (WP 0753).
2. Install HVAC fresh air inlet tube (WP 0720).
3. Install HVAC/LSS defogging air duct (WP 0754).
4. Install communications rack (WP 0667).
5. Remove wheel chocks (TM 9-2355-106-10).

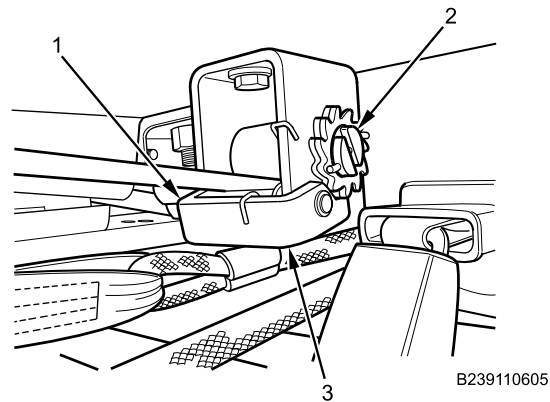
END OF TASK**END OF WORK PACKAGE**

FIELD MAINTENANCE

HEATING VENTILATING AND AIR CONDITIONING (HVAC)/LIFE SUPPORT SYSTEM (LSS) AIR DUCT
LOUVER REMOVAL AND INSTALLATION

INITIAL SETUP:

Tools and Special Tools

General Mechanic's Tool Kit (GMTK) WP 0795, Item 37

References

TM 9-2355-106-10
TM 9-2355-106-23P
WP 0782

Equipment Condition

Parking brake set (TM 9-2355-106-10)
Transmission set in NEUTRAL (N) (TM 9-2355-106-10)
Engine shut off (TM 9-2355-106-10)
MAIN POWER switch off (TM 9-2355-106-10)
Wheels chocked (TM 9-2355-106-10)

REMOVAL

NOTE

Forward facing right side center louver shown. Other forward facing louvers similar.

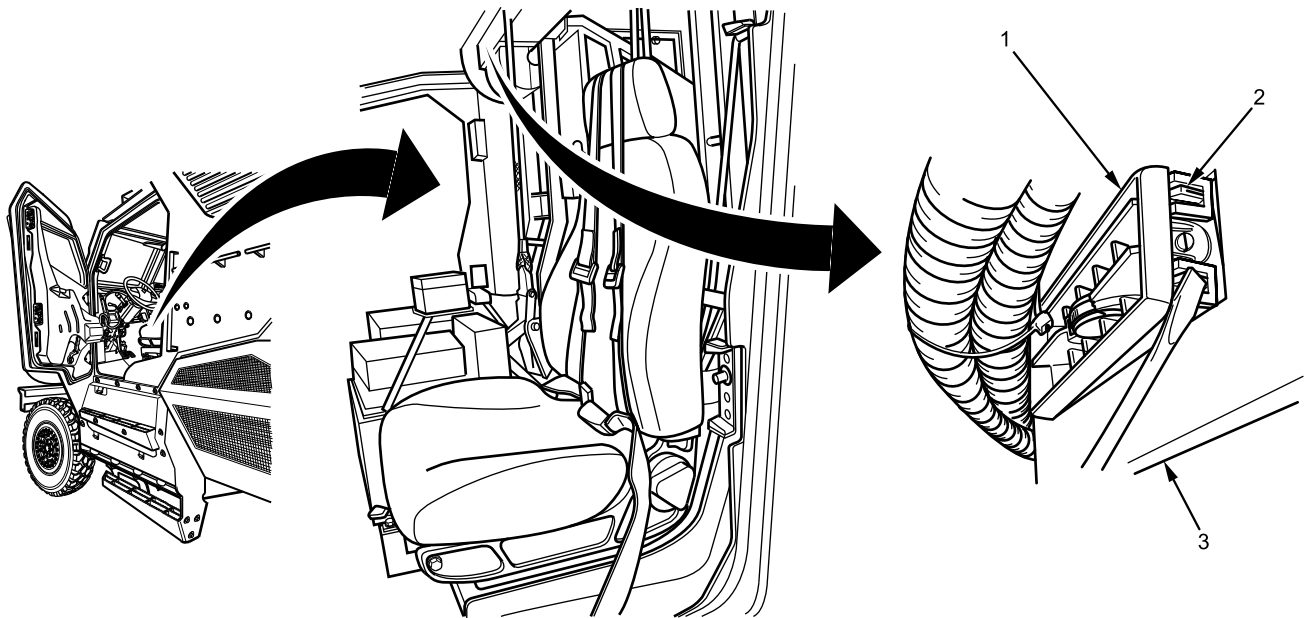

B239110592

Figure 1. Forward Facing Right Side Center Louver.

1. Carefully disengage retaining tabs (Figure 1, Item 2) on forward facing louver (Figure 1, Item 1) and remove louver from main air duct (Figure 1, Item 3).

HEATING VENTILATING AND AIR CONDITIONING (HVAC)/LIFE SUPPORT SYSTEM (LSS) AIR DUCT LOUVER REMOVAL AND INSTALLATION - (CONTINUED)

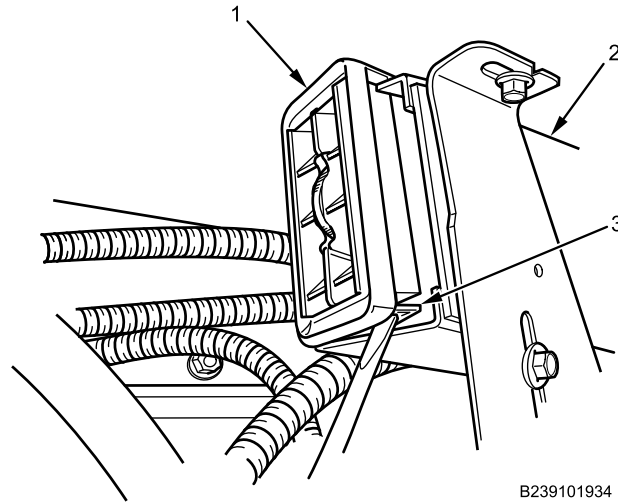

Figure 2. Rear Facing Left Side Louver.

NOTE

Rear facing left side louver shown. Rear facing right side louver similar.

- Carefully disengage retaining tabs (Figure 2, Item 3) on rear facing side louver (Figure 2, Item 1) and remove louver from main air duct (Figure 2, Item 2).

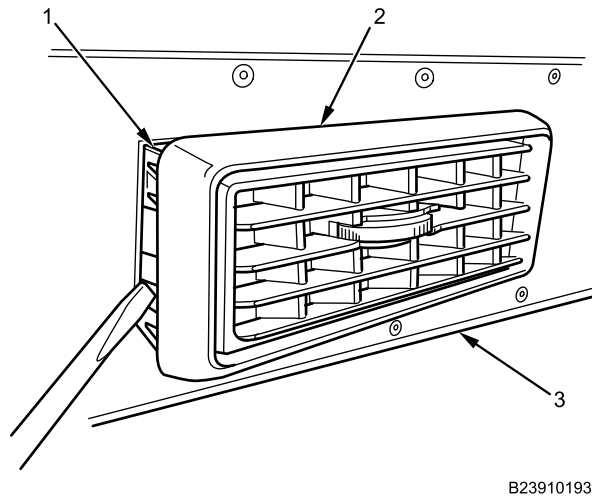
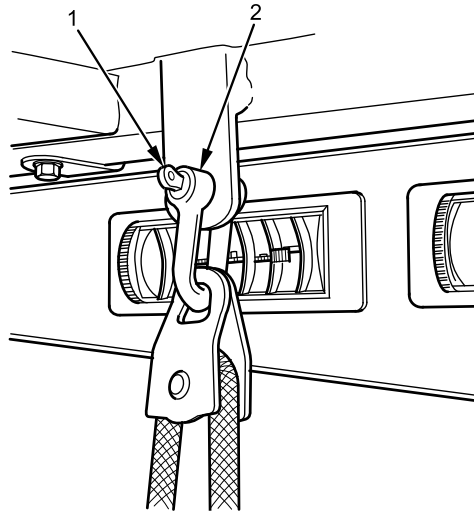

Figure 3. Rear Facing Right Side Center Louver.

**HEATING VENTILATING AND AIR CONDITIONING (HVAC)/LIFE SUPPORT SYSTEM (LSS) AIR DUCT
LOUVER REMOVAL AND INSTALLATION - (CONTINUED)****NOTE**

Rear facing right side center louver shown. Other rear facing center louver removal similar, except for rear facing louver behind seat suspension mount.

3. Carefully disengage retaining tabs (Figure 3, Item 1) on rear facing center louver (Figure 3, Item 2) and remove louver from main air duct (Figure 3, Item 3).



P239101062

Figure 4. Seat Suspension Mount Clevis and Pin.

4. To remove rear facing louver behind seat suspension mount, release tension on seat suspension (WP 0663) and remove clevis pin (Figure 4, Item 1) and clevis (Figure 4, Item 2).
5. Carefully disengage retaining tabs and remove louver from air duct.

END OF TASK

HEATING VENTILATING AND AIR CONDITIONING (HVAC)/LIFE SUPPORT SYSTEM (LSS) AIR DUCT LOUVER REMOVAL AND INSTALLATION - (CONTINUED)

INSTALLATION

NOTE

Rear facing left side louver shown. Rear facing right side louver similar.

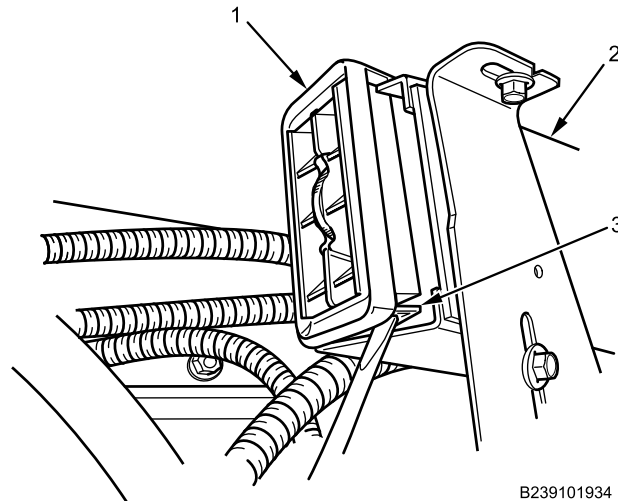

Figure 5. Rear Facing Left Side Louver.

1. Push rear facing side louver (Figure 5, Item 1) into main air duct (Figure 5, Item 2) until retaining tabs (Figure 5, Item 3) engage air duct securely.

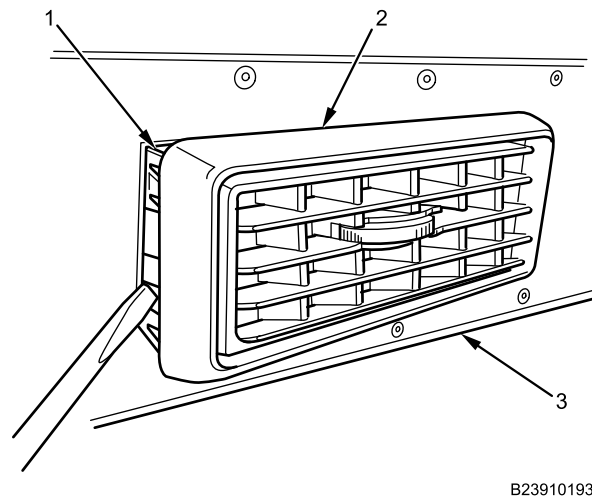

Figure 6. Rear Facing Right Side Center Louver.

NOTE

Rear facing right side center louver shown. Other rear facing center louvers similar, except for rear facing louver behind seat suspension mount.

2. Push rear facing center louver (Figure 6, Item 2) into main air duct (Figure 6, Item 3) until retaining tabs (Figure 6, Item 1) engage air duct securely.

HEATING VENTILATING AND AIR CONDITIONING (HVAC)/LIFE SUPPORT SYSTEM (LSS) AIR DUCT LOUVER REMOVAL AND INSTALLATION - (CONTINUED)

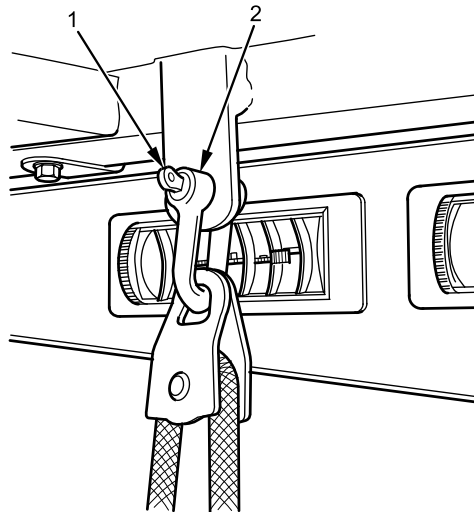

P239101062

Figure 7. Seat Suspension Mount Clevis and Pin.

3. To install rear facing louver behind seat suspension mount, push louver into air duct until retaining tabs engage air duct securely.
4. Install seat suspension mount clevis (Figure 7, Item 2) and pin (Figure 7, Item 1) and tighten seat suspension (WP 0663).

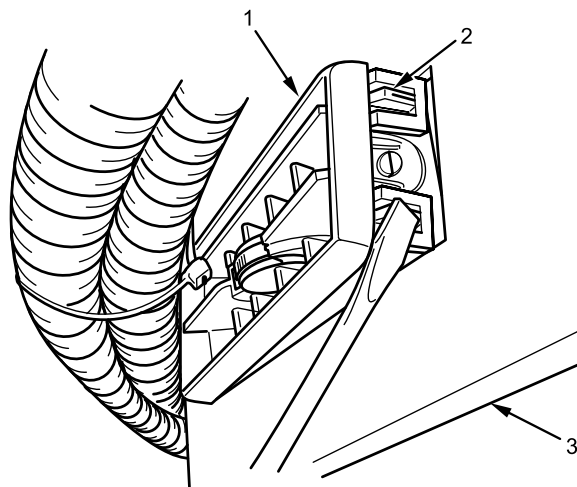

B239101936

Figure 8. Forward Facing Right Side Center Louver.

NOTE

Forward facing right side center louver shown. Other forward facing louvers similar.

5. Push forward facing louver (Figure 8, Item 1) into main air duct (Figure 8, Item 3) until retaining tabs (Figure 8, Item 2) engage air duct securely.

END OF TASK

**HEATING VENTILATING AND AIR CONDITIONING (HVAC)/LIFE SUPPORT SYSTEM (LSS) AIR DUCT
LOUVER REMOVAL AND INSTALLATION - (CONTINUED)**

FOLLOW-ON MAINTENANCE

1. Remove wheel chocks (TM 9-2355-106-10).

END OF TASK

END OF WORK PACKAGE

FIELD MAINTENANCE**HEATING VENTILATING AND AIR CONDITIONING (HVAC)/LIFE SUPPORT SYSTEM (LSS) DEFOGGING AIR DUCT REMOVAL AND INSTALLATION**

INITIAL SETUP:**Tools and Special Tools**

General Mechanic's Tool Kit (GMTK)
(WP 0795, Item 37)

WP 0786

WP 0782

Materials/Parts

Cable lock strap (WP 0796, Item 120)
Tape (WP 0794, Item 51)
Fasteners (WP 0796, Item 159)

Equipment Condition

Parking brake set (TM 9-2355-106-10)

Transmission set in NEUTRAL (N) (TM
9-2355-106-10)

Engine off (TM 9-2355-106-10)

MAIN POWER switch off (TM 9-2355-106-10)

Wheels chocked (TM 9-2355-106-10)

Electronics equipment removed from defogging air
duct**References**

TM 9-2355-106-10

TM 9-2355-106-23P

NOTE

Remove cable lock straps as necessary to perform procedure. Note position and size of cable lock straps to aid installation.

HEATING VENTILATING AND AIR CONDITIONING (HVAC)/LIFE SUPPORT SYSTEM (LSS) DEFOGGING AIR DUCT REMOVAL AND INSTALLATION - (CONTINUED)

REMOVAL

1. Loosen Velcro® (Figure 1, Item 7) from defogging air duct (Figure 1, Item 9) and main air duct (Figure 1, Item 8).

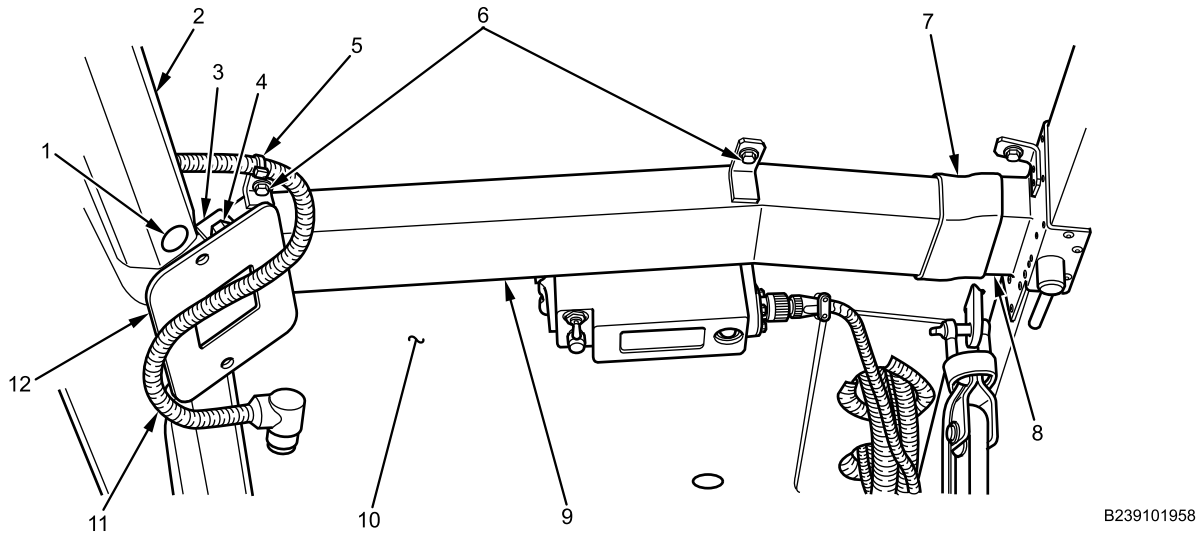

Figure 1. Defogging Air Duct Mounting.

2. Remove duct tape from seam between defogging air duct (Figure 1, Item 9) and main air duct (Figure 1, Item 8).
3. Remove six fasteners (Figure 1, Item 1) from right and left interior windshield trim (Figure 1, Item 2).
4. Remove two nuts (Figure 1, Item 4) from plate support mount (Figure 1, Item 3) and plate assembly mount (Figure 1, Item 12).
5. Remove plate assembly mount (Figure 1, Item 12).
6. Remove right and left interior windshield trim (Figure 1, Item 2) from roof headliner (Figure 1, Item 10).
7. Cut cable lock strap (Figure 1, Item 5) from wire harness (Figure 1, Item 11). Discard cable lock strap.
8. Remove three bolts (Figure 1, Item 6), spacers, and flat washers from defogging air duct (Figure 1, Item 9).
9. Remove defogging air duct (Figure 1, Item 9) from main air duct (Figure 1, Item 8) and roof headliner (Figure 1, Item 10).

END OF TASK

HEATING VENTILATING AND AIR CONDITIONING (HVAC)/LIFE SUPPORT SYSTEM (LSS) DEFOGGING AIR DUCT REMOVAL AND INSTALLATION - (CONTINUED)

INSTALLATION

1. Install defogging air duct (Figure 2, Item 9) on main air duct (Figure 2, Item 8) and roof headliner (Figure 2, Item 10) with three bolts (Figure , Item 6) , spacers, and flat washers. Tighten bolts securely.

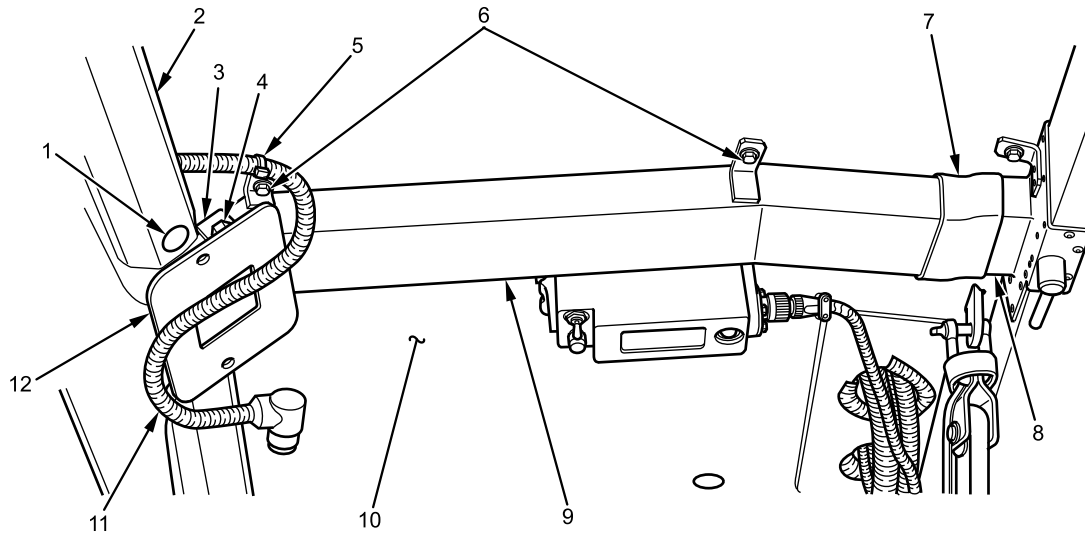

B239101958

Figure 2. Defogging Air Duct Mounting.

2. Install duct tape at seam between main air duct (Figure 2, Item 8) and defogging air duct (Figure 2, Item 9).
3. Install Velcro® (Figure 2, Item 7) at seam between main air duct (Figure 2, Item 8) and defogging air duct (Figure 2, Item 9).
4. Install right and left interior windshield trim (Figure 2, Item 2) with six fasteners (Figure 2, Item 1).
5. Install plate assembly mount (Figure 2, Item 12) and two nuts (Figure 2, Item 4) to plate support mount (Figure 2, Item 3).
6. Install wire harness (Figure 2, Item 11) on defogging air duct (Figure 2, Item 9) with new cable lock strap (Figure 2, Item 5).
7. Install all cable lock straps and tighten securely.

END OF TASK

FOLLOW-ON MAINTENANCE

END OF TASK

ADDITIONAL MAINTENANCE TASK

1. Install electronics equipment on defogging air duct.
2. Remove wheel chocks (TM 9-2355-106-10).

END OF TASK

END OF WORK PACKAGE

FIELD MAINTENANCE

HEATING VENTILATING AND AIR CONDITIONING (HVAC)/LIFE SUPPORT SYSTEM (LSS) DIFFUSER AIR DUCT REMOVAL AND INSTALLATION

INITIAL SETUP:

Tools and Special Tools

General Mechanic's Tool Kit (GMTK)
(WP 0795, Item 37)

References

TM 9-2355-106-10
TM 9-2355-106-23P
WP 0786
WP 0782

Equipment Condition

Parking brake set (TM 9-2355-106-10)
Transmission set in NEUTRAL (N) (TM 9-2355-106-10)
Engine off (TM 9-2355-106-10)
MAIN POWER switch off (TM 9-2355-106-10)
Wheels chocked (TM 9-2355-106-10)
HVAC upper panel removed (WP 0767)

CAUTION

Blower motor fan housing is secured using the eight bolts, on the diffuser air duct. Ensure blower motor does not drop when eight bolts are removed.

REMOVAL

1. Remove eight bolts (Figure 1, Item 3), lockwashers (Figure 1, Item 4), and washers (Figure 1, Item 5) from diffuser air duct (Figure 1, Item 6). Discard lockwashers.

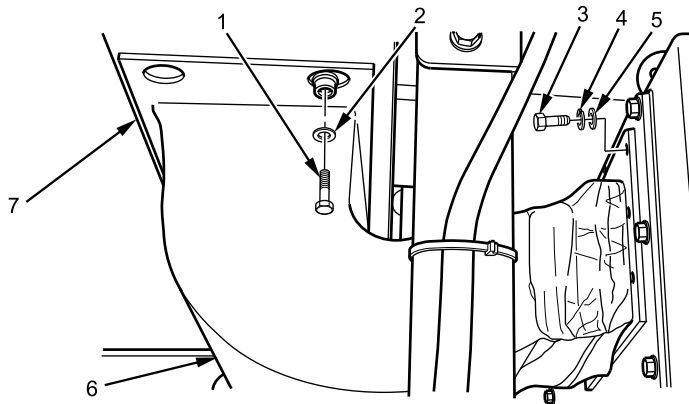

B235210862

Figure 1. Diffuser Air Duct.

2. Remove four bolts (Figure 1, Item 1) and flat washers (Figure 1, Item 2) from diffuser air duct (Figure 1, Item 5).
3. Remove diffuser air duct (Figure 1, Item 6) from main air duct (Figure 1, Item 7).

END OF TASK

HEATING VENTILATING AND AIR CONDITIONING (HVAC)/LIFE SUPPORT SYSTEM (LSS) DIFFUSER AIR DUCT REMOVAL AND INSTALLATION - (CONTINUED)

INSTALLATION

1. Install diffuser air duct (Figure 2, Item 6) on main air duct (Figure 2, Item 7) with four bolts (Figure 2, Item 1) and flat washers (Figure 2, Item 2) and tighten securely.

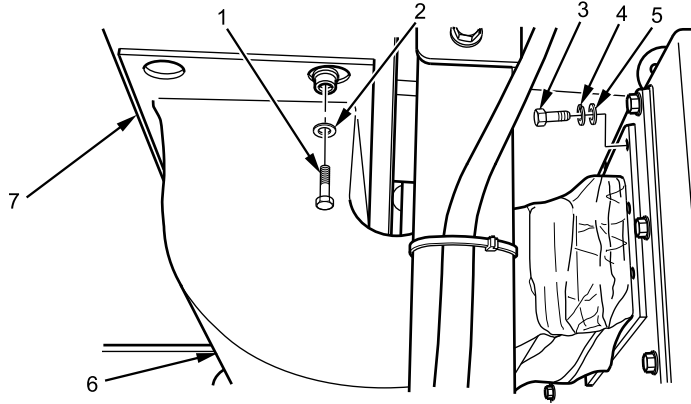

B235210862

Figure 2. Diffuser Air Duct.

2. Install diffuser air duct (Figure 2, Item 6) on blower mounting panel with eight bolts (Figure 2, Item 3) and new lockwashers (Figure 2, Item 4), and washers (Figure 2, Item 5). Tighten bolts securely.

END OF TASK

FOLLOW-ON MAINTENANCE

1. Install HVAC upper panel (WP 0767).
2. Remove wheel chocks (TM 9-2355-106-10).

END OF TASK

END OF WORK PACKAGE

FIELD MAINTENANCE

HEATING VENTILATING AND AIR CONDITIONING (HVAC)/LIFE SUPPORT SYSTEM (LSS) FRESH AIR INLET FLANGE REMOVAL AND INSTALLATION

INITIAL SETUP:

Tools and Special Tools

General Mechanic's Tool Kit (GMTK)
(WP 0795, Item 37)

TM 9-2355-106-23P

WP 0786

WP 0782

Materials/Parts

Goggles, industrial (WP 0794, Item 20)
Faceshield, industrial (WP 0794, Item 16)
Gasket (WP 0796, Item 180)
Sealing compound (WP 0794, Item 43)
Gloves (WP 0794, Item 18)

Equipment Condition

Parking brake set (TM 9-2355-106-10)
Transmission set in NEUTRAL (N) (TM 9-2355-106-10)
Engine off (TM 9-2355-106-10)
MAIN POWER switch off (TM 9-2355-106-10)
Wheels chocked (TM 9-2355-106-10)
Roof armor front spoiler removed (WP 0585)

Personnel Required

Maintainer - (2)

References

TM 9-2355-106-10

REMOVAL

1. Loosen hose clamp (Figure 1, Item 2) on fresh air inlet tube (Figure 1, Item 5).

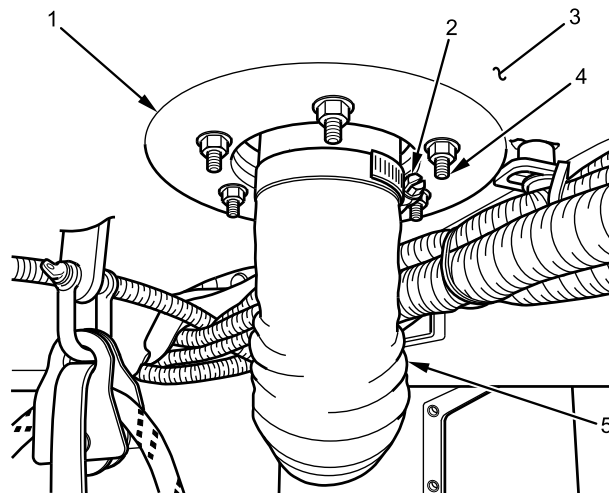

Figure 1. Fresh Air Inlet Flange.

2. Remove fresh air inlet tube (Figure 1, Item 5) from fresh air inlet flange (Figure 1, Item 1).

NOTE

Assistant required to hold bolts on roof while other maintainer removes nuts during next step.

3. With assistant, remove six bolts (Figure 1, Item 4) and nuts from fresh air inlet flange (Figure 1, Item 1).
4. Remove fresh air inlet flange (Figure 1, Item 1) and gasket from roof (Figure 1, Item 3). Discard gasket.

END OF TASK

HEATING VENTILATING AND AIR CONDITIONING (HVAC)/LIFE SUPPORT SYSTEM (LSS) FRESH AIR INLET FLANGE REMOVAL AND INSTALLATION - (CONTINUED)

INSTALLATION

WARNING



Sealing compound is toxic. Use only in well-ventilated area. Do not get in eyes; wear chemical safety goggles and full-face shield when using. Avoid contact with skin and wear rubber or plastic, solvent-resistant gloves. In case of contact, remove contaminated clothing and immediately wash area with soap and water. If compound contacts eyes, flush eyes with large amounts of water for at least 15 minutes and get immediate medical attention. If swallowed, do not induce vomiting; contact a physician immediately. Failure to comply may result in serious injury or death to personnel.

1. Apply gasket sealer around each bolt hole on gasket (Figure 2, Item 8).

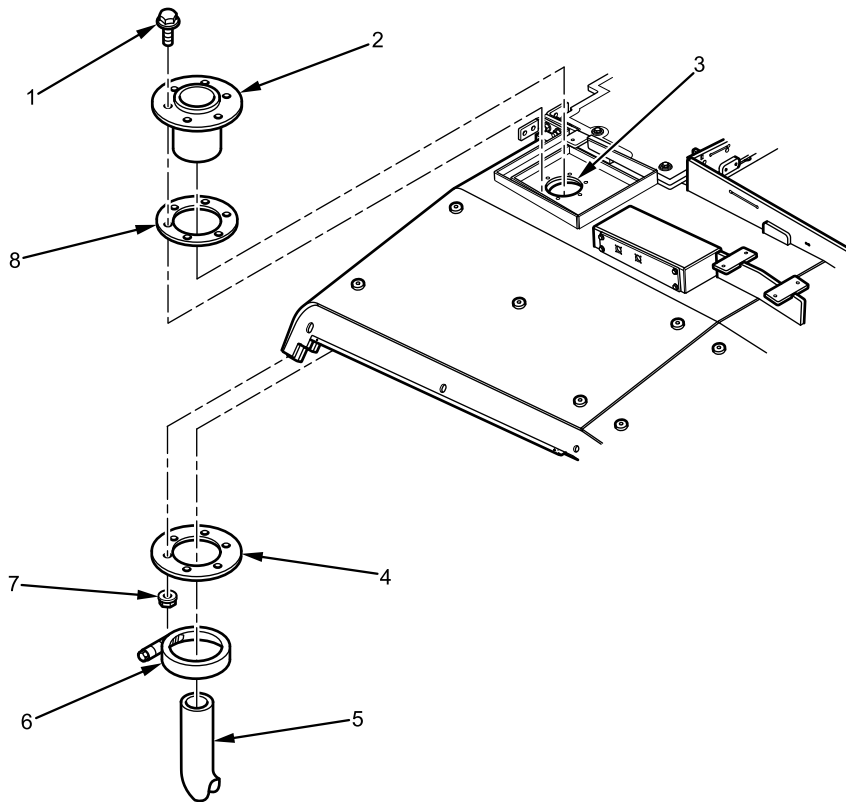

B239103404

Figure 2. Fresh Air Inlet Flange.

2. Position fresh air inlet flange (Figure 2, Item 2) and gasket (Figure 2, Item 8) on roof (Figure 2, Item 3) with six bolts (Figure 2, Item 1).

NOTE

Assistant required to hold bolts on roof while other maintainer tightens nuts during next step.

HEATING VENTILATING AND AIR CONDITIONING (HVAC)/LIFE SUPPORT SYSTEM (LSS) FRESH AIR INLET FLANGE REMOVAL AND INSTALLATION - (CONTINUED)

3. With assistant, install retainer ring (Figure 2, Item 4) with six nuts (Figure 2, Item 7) and tighten securely.
4. Install fresh air inlet tube (Figure 2, Item 5) on fresh air inlet flange (Figure 2, Item 2) with hose clamp (Figure 2, Item 6) and tighten securely.

END OF TASK**FOLLOW-ON MAINTENANCE**

1. Install roof armor front spoiler (WP 0585).
2. Remove wheel chocks (TM 9-2355-106-10).

END OF TASK**END OF WORK PACKAGE**

FIELD MAINTENANCE

HEATING VENTILATING AND AIR CONDITIONING (HVAC)/LIFE SUPPORT SYSTEM (LSS) OVERPRESSURE RELIEF VALVE REMOVAL AND INSTALLATION

INITIAL SETUP:

Tools and Special Tools

General Mechanic's Tool Kit (GMTK)
(WP 0795, Item 37)

TM 9-2355-106-23P

WP 0786

WP 0782

Materials/Parts

Compound (WP 0794, Item 13)
Gloves (WP 0794, Item 28)
Goggles, industrial (WP 0794, Item 20)
Faceshield, industrial (WP 0794, Item 16)
Gloves (WP 0794, Item 18)
O-ring (WP 0796, Item 126)

Equipment Condition

Parking brake set (TM 9-2355-106-10)
Transmission set in NEUTRAL (N) (TM 9-2355-106-10)
Engine off (TM 9-2355-106-10)
MAIN POWER switch off (TM 9-2355-106-10)
Wheels chocked (TM 9-2355-106-10)

References

TM 9-2355-106-10

REMOVAL

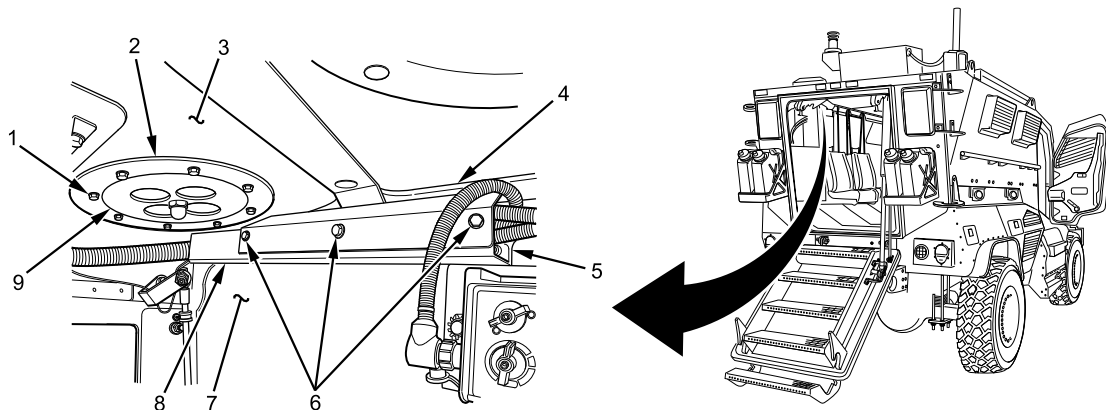

B239110864

Figure 1. Overpressure Relief Valve Mounting.

1. Remove three bolts (Figure 1, Item 6) and flat washers from wire harness shield cover (Figure 1, Item 4).
2. Remove wire harness shield cover (Figure 1, Item 4) from wire harness shield (Figure 1, Item 8).
3. Remove two nuts (Figure 1, Item 5) from wire harness shield (Figure 1, Item 8). One nut shown. One nut hidden from view.
4. Remove wire harness shield (Figure 1, Item 8) from left rear wall (Figure 1, Item 7).

NOTE

Note orientation of overpressure relief valve prior to removal to aid in proper installation.

5. Remove eight bolts (Figure 1, Item 1) from overpressure relief valve retaining ring (Figure 1, Item 2).
6. Remove overpressure relief valve retaining ring (Figure 1, Item 2) from headliner (Figure 1, Item 3).
7. Remove overpressure relief valve (Figure 1, Item 9) from headliner (Figure 1, Item 3).

HEATING VENTILATING AND AIR CONDITIONING (HVAC)/LIFE SUPPORT SYSTEM (LSS) OVERPRESSURE RELIEF VALVE REMOVAL AND INSTALLATION - (CONTINUED)

8. Remove overpressure relief valve shield assembly (Figure 2, Item 2) from roof (Figure 2, Item 1).

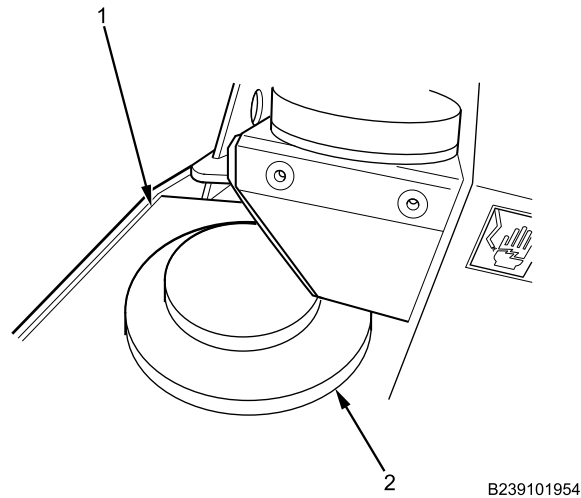

Figure 2. Overpressure Relief Valve Shield Assembly Mounting.

9. Remove three bolts (Figure 3, Item 1) and washers (Figure 3, Item 2) from overpressure relief valve shield assembly (Figure 3, Item 3 and 4).
10. Remove upper shield (Figure 3, Item 3) from lower shield (Figure 3, Item 4).

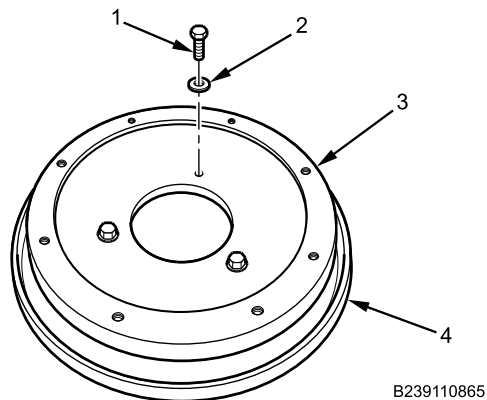
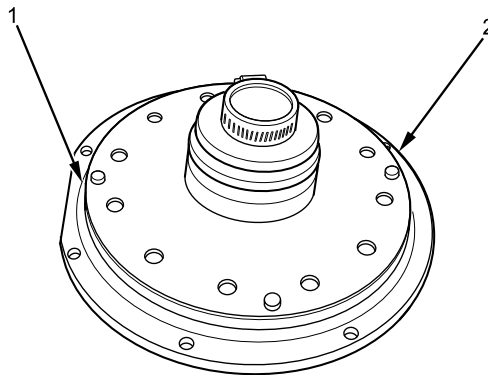

Figure 3. Overpressure Relief Valve Shield Assembly.

HEATING VENTILATING AND AIR CONDITIONING (HVAC)/LIFE SUPPORT SYSTEM (LSS) OVERPRESSURE RELIEF VALVE REMOVAL AND INSTALLATION - (CONTINUED)

11. Remove O-ring (Figure 4, Item 1) from overpressure relief valve (Figure 4, Item 2). Discard O-ring.



B239101953

Figure 4. Overpressure Relief Valve O-Ring.

END OF TASK**INSTALLATION****WARNING**

Corrosion preventive compound is toxic. Use only in well-ventilated area. Do not get in eyes; wear chemical safety goggles and full-face shield when using. Avoid contact with skin and wear rubber or plastic, solvent-resistant gloves. In case of contact, remove contaminated clothing and immediately wash area with soap and water. If compound contacts eyes, flush eyes with large amounts of water for at least 15 minutes and get immediate medical attention. If swallowed, do not induce vomiting; contact a physician immediately. Failure to comply may result in serious injury or death to personnel.

1. Apply corrosion preventive compound to three bolts (Figure 3, Item 1) and washers (Figure 3, Item 2).
2. Install overpressure relief valve upper shield (Figure 3, Item 3) on overpressure relief valve lower shield (Figure 3, Item 4) with three bolts (Figure 3, Item 1) and washers (Figure 3, Item 2) and tighten securely.

HEATING VENTILATING AND AIR CONDITIONING (HVAC)/LIFE SUPPORT SYSTEM (LSS) OVERPRESSURE RELIEF VALVE REMOVAL AND INSTALLATION - (CONTINUED)

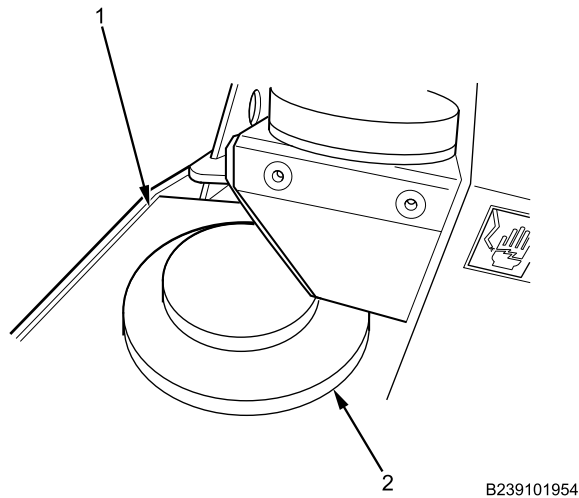

Figure 5. Overpressure Relief Valve Shield Assembly Mounting.

3. Position overpressure relief valve shield assembly (Figure 5, Item 2) on roof (Figure 5, Item 1) with holes aligned.

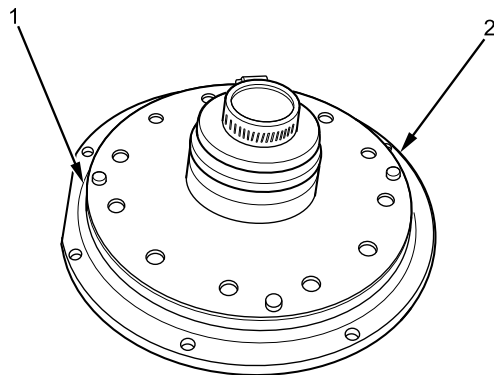

Figure 6. Overpressure Relief Valve O-Ring.

WARNING



Ensure overpressure relief valve O-ring is clean and properly installed on overpressure relief valve. A leaking O-ring could cause outside contaminants to leak into cabin as a result of low cabin pressure. Failure to comply may result in serious injury or death to personnel.

4. Install new overpressure relief valve O-ring (Figure 6, Item 1) in groove of overpressure relief valve (Figure 6, Item 2).

HEATING VENTILATING AND AIR CONDITIONING (HVAC)/LIFE SUPPORT SYSTEM (LSS) OVERPRESSURE RELIEF VALVE REMOVAL AND INSTALLATION - (CONTINUED)

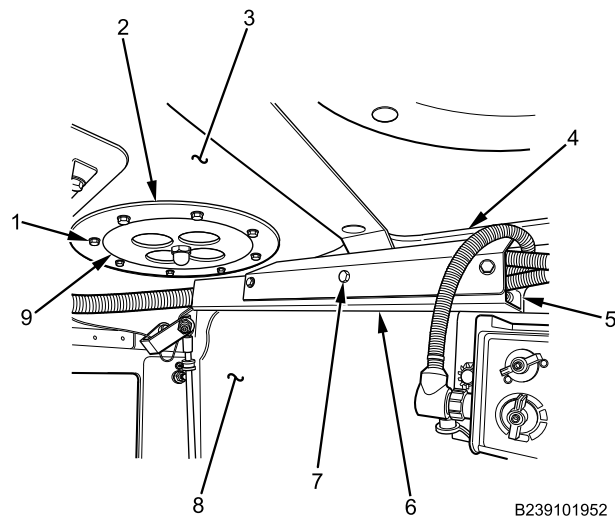

Figure 7. Overpressure Relief Valve Mounting.

WARNING

The headliner must not be pinched between the overpressure relief valve and the roof. The overpressure relief valve must be installed above the headliner to obtain a good seal. Failure to comply may result in serious injury or death to personnel.

Ensure area where overpressure relief valve O-ring contacts vehicle roof is clean. O-ring contact area should also be smooth and free of cracks that could allow cabin pressure loss. Failure to comply may result in serious injury or death to personnel.

5. Apply corrosion preventive compound to eight bolts (Figure 7, Item 1).
6. Install overpressure relief valve (Figure 7, Item 9) above headliner (Figure 7, Item 3), with overpressure relief valve retaining ring (Figure 7, Item 2) and eight bolts (Figure 7, Item 1). Tighten bolts securely.
7. Install wire harness shield (Figure 7, Item 6) on left rear wall (Figure 7, Item 8) with two nuts (Figure 7, Item 5) and tighten securely. One nut shown. One nut hidden from view.
8. Install wire harness shield cover (Figure 7, Item 4) on wire harness shield (Figure 7, Item 6) with three bolts (Figure 7, Item 7) and flat washers and tighten securely.

END OF TASK

HEATING VENTILATING AND AIR CONDITIONING (HVAC)/LIFE SUPPORT SYSTEM (LSS) OVERPRESSURE RELIEF VALVE REMOVAL AND INSTALLATION - (CONTINUED)**FOLLOW-ON MAINTENANCE**

1. Turn MAIN POWER switch on (TM 9-2355-106-10).
2. Start engine (TM 9-2355-106-10).
3. Close all doors and hatches securely (TM 9-2355-106-10).
4. Turn on HVAC/LSS to verify proper cabin pressure (TM 9-2355-106-10).
5. Turn HVAC/LSS off (TM 9-2355-106-10).
6. Turn engine off (TM 9-2355-106-10).
7. Turn MAIN POWER switch off (TM 9-2355-106-10).
8. Remove wheel chocks (TM 9-2355-106-10).

END OF TASK**END OF WORK PACKAGE**

FIELD MAINTENANCE**HEATING VENTILATING AND AIR CONDITIONING (HVAC) RECEIVER/DRIER REMOVAL AND INSTALLATION**

INITIAL SETUP:**Tools and Special Tools**

General Mechanic's Tool Kit (GMTK)
(WP 0795, Item 37)
Refrigeration Ordnance Service Tool Kit
(WP 0795, Item 85)
Measure, liquid, 2 qt (WP 0795, Item 71)

Materials/Parts

Faceshield, industrial (WP 0794, Item 16)
Lubricating oil (WP 0794, Item 31)
Lockwasher - (2) (WP 0796, Item 172)
Lockwasher - (4) (WP 0796, Item 168)
O-ring - (2) (WP 0796, Item 34)
O-ring - (2) (WP 0796, Item 36)
O-ring (WP 0796, Item 171)

Personnel Required

Maintainer - (2)

References

TM 9-2355-106-10
TM 9-2355-106-23P
WP 0786
WP 0782

Equipment Condition

Parking brake set (TM 9-2355-106-10)
Transmission set in NEUTRAL (N) (TM 9-2355-106-10)
Engine off (TM 9-2355-106-10)
MAIN POWER switch off (TM 9-2355-106-10)
Wheels chocked (TM 9-2355-106-10)
Engine hood open and secured (TM 9-2355-106-10)
HVAC/Life Support System (LSS) upper panel removed (WP 0767)
HVAC system evacuated and discharged (WP 0707)

HEATING VENTILATING AND AIR CONDITIONING (HVAC) RECEIVER/DRIER REMOVAL AND INSTALLATION - (CONTINUED)

WARNING

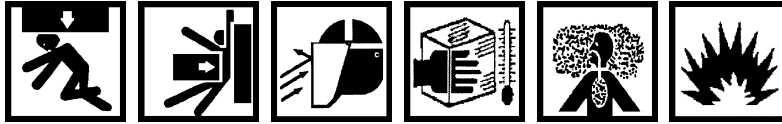

Engine hood is extremely heavy and requires two-person lift. Ensure that there is adequate space in front of the vehicle to open hood completely without pinning or pinching personnel between hood and any other structure. Use extreme care when working under hood and make sure it is properly supported. Failure to comply may result in serious injury or death to personnel.

Do not install or remove air-conditioning testing or charging equipment while engine is running. Wait 30 seconds after engine shutdown to allow high side and low side pressures to equalize. Failure to comply may result in damage to equipment and environment, and serious injury or death to personnel.

Never open the high side hand valve of the manifold gauge set while HVAC system is operating. If hot, high pressure refrigerant is forced through gauge to refrigerant supply cylinder, which could rupture. Failure to comply may result in damage to equipment and environment, and serious injury or death to personnel.

The temperature of liquid refrigerant is -20°F (-29°C). Wear full face shield, protective rubberized gloves, and protective clothing when working with refrigerant. If refrigerant contacts skin, remove all contaminated clothing. Treat skin as though it were frostbitten or frozen and seek immediate medical attention. If refrigerant contacts eyes, do not rub them. Flush eyes with cold water for at least 15 minutes to gradually increase temperature above freezing point. Seek immediate medical attention. Failure to comply may result in serious injury or death to personnel.

Do not expose refrigerant containers, empty or full, to open flames or temperatures above 125°F (52°C). Do not discard empty containers where they may be subject to heat from a trash burner; containers may explode. Failure to comply may result in damage to equipment and serious injury or death to personnel.

Refrigerant becomes a poisonous gas in the presence of heat. Do not smoke or allow any type of flame in immediate area while servicing air conditioning system. Never weld, solder, steam clean, or use excessive heat on any part of the air conditioning system while charged/pressurized. Failure to comply may result in damage to equipment and serious injury or death to personnel.

R-134a refrigerant must not be mixed with air and then pressurized. When mixed with large quantities of air and pressurized, R-134a becomes combustible. Failure to comply may result in damage to equipment and environment, and serious injury or death to personnel.

Refrigerant evaporates very quickly and may displace oxygen in surrounding work area, especially in a small or enclosed area. This can cause suffocation or brain damage. If leak occurs, avoid breathing refrigerant vapor and thoroughly ventilate area before continuing service. If personnel breathe refrigerant vapors, obtain immediate medical assistance. Failure to comply may result in serious injury or death to personnel.

Federal and state laws require that refrigerant be recovered and recycled. Refrigerant must be recovered from system with authorized recommended equipment before any work can be performed on unit. Always use approved recycling equipment to prevent accidental discharge. Failure to comply may result in damage to equipment and environment, and serious injury or death to personnel.

HEATING VENTILATING AND AIR CONDITIONING (HVAC) RECEIVER/DRIER REMOVAL AND INSTALLATION - (CONTINUED)

Do not check compressor oil level when HVAC system is charged with refrigerant. Never open the high side hand valve of the manifold gauge set while HVAC system is operating. If hot, high pressure refrigerant is forced through gauge to refrigerant supply cylinder, which could rupture. Do not disconnect HVAC lines from compressor. Release of refrigerant may cause damage to equipment or environment and serious injury or death to personnel.

Do not use parts other than those specified for the system being serviced. Failure to comply may result in damage to equipment and serious injury or death to personnel.

Accidental or intentional introduction of liquid contaminants into the environment is a violation of state, federal, and military regulations. Store, install, and dispose of containers in accordance with standard operating procedures. Refer to Army Petroleum, Oil, and Lubricants (POL) (para. 1-8) for information concerning storage, use, and disposal of liquid contaminants. Failure to comply may result in damage to environment and serious injury or death to personnel.

REMOVAL

1. Remove heatshrink tubing (Figure 1, Item 1) from receiver/drier inlet hose connection at evaporator assembly (Figure 1, Item 3). Discard heat shrink tubing.

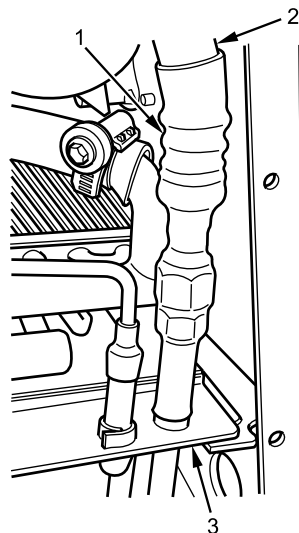

B235201691

Figure 1. Inlet Hose at Evaporator Assembly.

2. Disconnect receiver/drier inlet hose (Figure 1, Item 2) from evaporator assembly (Figure 1, Item 3).

HEATING VENTILATING AND AIR CONDITIONING (HVAC) RECEIVER/DRIER REMOVAL AND INSTALLATION - (CONTINUED)

3. Remove heatshrink tubing (Figure 2, Item 2) from receiver/drier inlet hose connection at receiver/drier (Figure 2, Item 3). Discard heat shrink tubing.

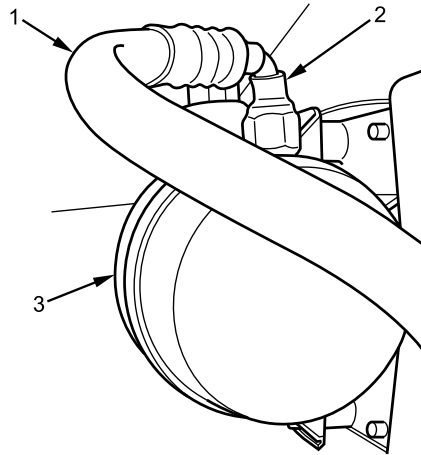

B235201692

Figure 2. Inlet Hose at Receiver/Drier.

4. Disconnect receiver/drier inlet hose connection at receiver/drier (Figure 2, Item 3) and remove receiver/drier inlet hose (Figure 2, Item 1). Avoid spilling PAG oil.
5. Pour PAG oil from receiver/drier inlet hose (Figure 2, Item 1) into measured container.
6. Remove O-rings from receiver/drier inlet hose (Figure 2, Item 1). Discard O-rings.
7. Disconnect LSS harness connector (Figure 3, Item 2) from bracket (Figure 3, Item 4).

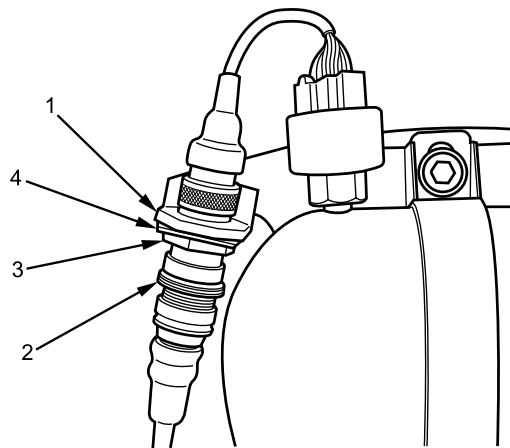

B235201693

Figure 3. Pressure Switch Connection.

8. Remove nut (Figure 3, Item 3) and remove high pressure switch harness locknut connector (Figure 3, Item 1) from bracket (Figure 3, Item 4).

**HEATING VENTILATING AND AIR CONDITIONING (HVAC) RECEIVER/DRIER REMOVAL AND INSTALLATION
- (CONTINUED)**

9. Remove heatshrink tubing (Figure 4, Item 3) from receiver/drier outlet hose (Figure 4, Item 1) at thermal expansion valve (Figure 4, Item 2). Discard heat shrink tubing.

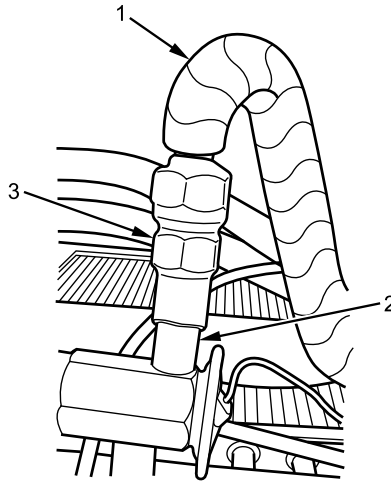

B235201694

Figure 4. Discharge Hose at Thermal Expansion Valve.

10. Disconnect receiver/drier outlet hose (Figure 4, Item 1) from thermal expansion valve (Figure 4, Item 2).

CAUTION

Avoid contact with heater radiator fins. Failure to comply may result in damage to heater radiator.

11. While supporting receiver/drier (Figure 5, Item 2), remove four bolts (Figure 5, Item 1) and remove receiver/drier. Avoid spilling PAG oil. Discard lockwashers.

HEATING VENTILATING AND AIR CONDITIONING (HVAC) RECEIVER/DRIER REMOVAL AND INSTALLATION - (CONTINUED)

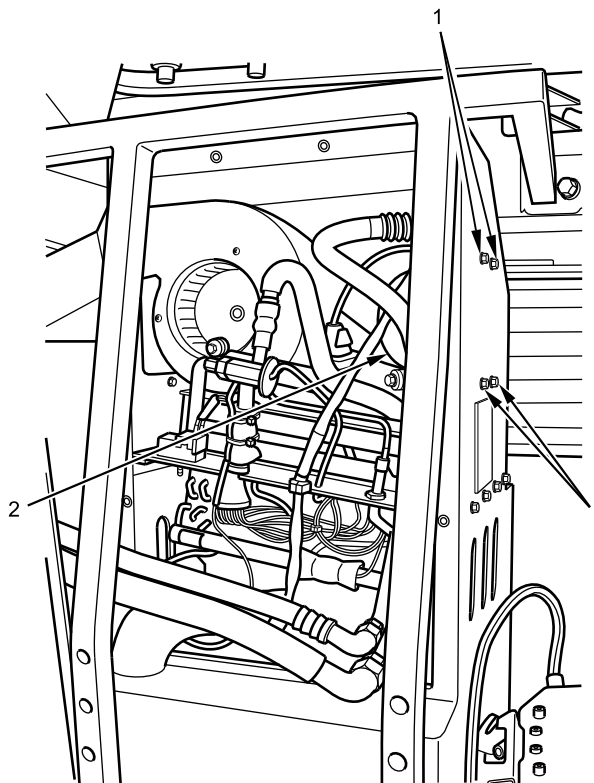

B235203376

Figure 5. Receiver/Drier Mounting Bolts.

12. Pour PAG oil from receiver/drier and receiver/drier outlet hose into measured container.
13. Remove heatshrink tubing (Figure 6, Item 2) from receiver/drier outlet hose (Figure 6, Item 3) at receiver/drier (Figure 6, Item 1). Discard heat shrink tubing.

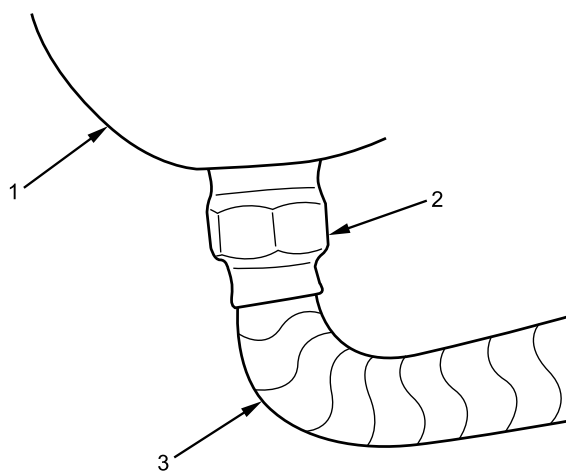

B235201696

Figure 6. Discharge Hose at Receiver/Drier.

14. Remove receiver/drier outlet hose (Figure 6, Item 3) from receiver/drier (Figure 6, Item 1).
15. Remove O-rings from receiver/drier outlet hose (Figure 6, Item 3). Discard O-rings.
16. Remove HVAC high pressure switch (Figure 7, Item 1) from receiver/drier (Figure 7, Item 2).

HEATING VENTILATING AND AIR CONDITIONING (HVAC) RECEIVER/DRIER REMOVAL AND INSTALLATION - (CONTINUED)

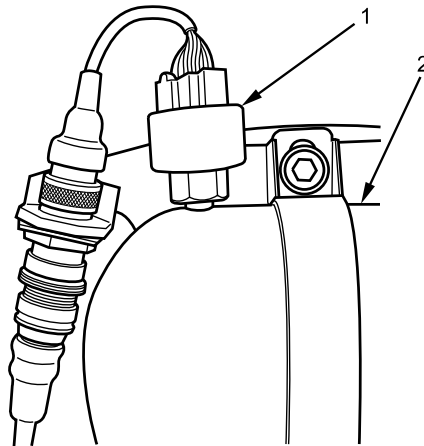

B235201711

Figure 7. High Pressure Switch.

17. Remove O-ring from HVAC high pressure switch (Figure 7, Item 1). Discard O-ring.
18. Remove two bolts (Figure 8, Item 1), flat washers and lockwashers from clamp (Figure 8, Item 4). Remove clamp and receiver/drier (Figure 8, Item 3) from receiver/drier mounting plate (Figure 8, Item 2). Discard lockwashers.

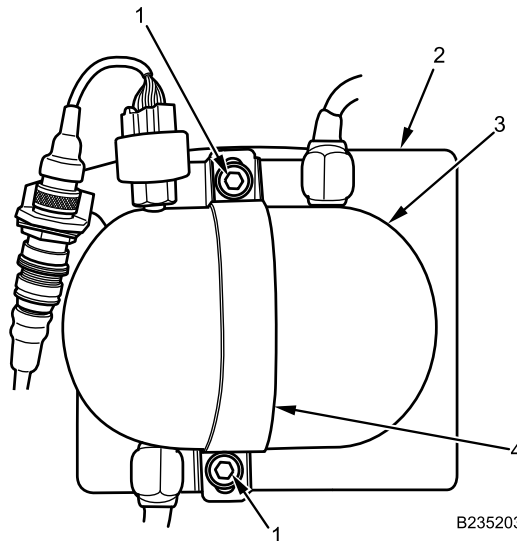

B235203377

Figure 8. Receiver/Drier Mounting Plate and Clamp.

END OF TASK

HEATING VENTILATING AND AIR CONDITIONING (HVAC) RECEIVER/DRIER REMOVAL AND INSTALLATION - (CONTINUED)

INSTALLATION

1. Install receiver/drier (Figure 9, Item 3) on receiver/drier mounting plate (Figure 9, Item 2) with clamp (Figure 9, Item 4), two bolts (Figure 9, Item 1), flat washers, and new lockwashers. Tighten finger-tight.

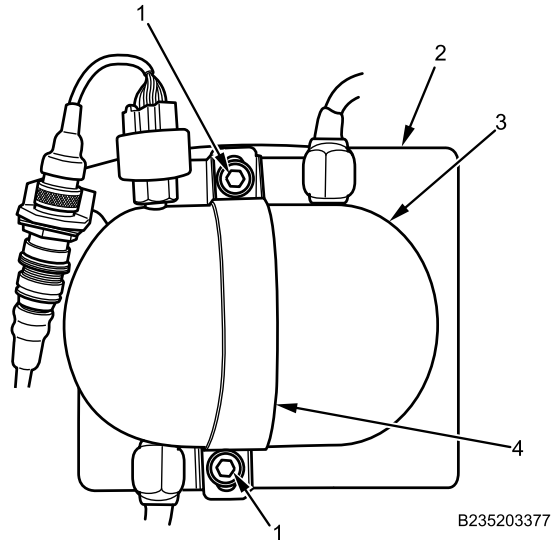

Figure 9. Receiver/Drier Mounting Plate and Clamp.

2. Coat new O-ring with PAG oil and install on HVAC high pressure switch (Figure 10, Item 1).

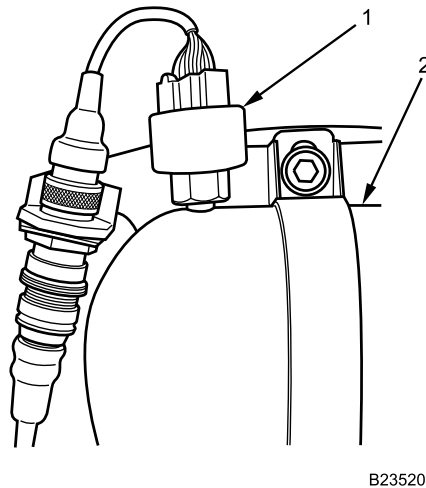
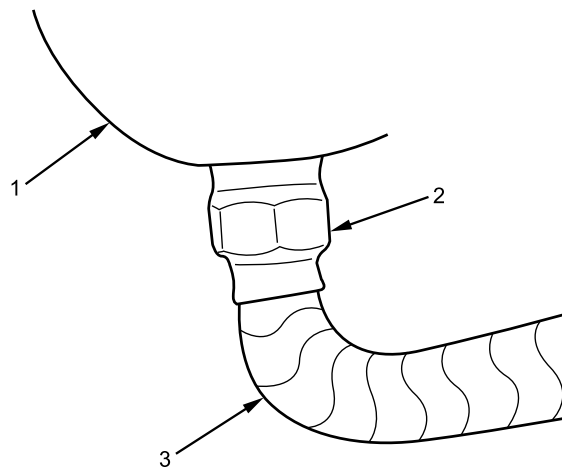

Figure 10. High Pressure Switch.

3. Install HVAC high pressure switch (Figure 10, Item 1) on receiver/drier (Figure 10, Item 2).
4. Coat new O-rings with PAG oil and install one O-ring on each end of receiver/drier outlet hose (Figure 11, Item 3).

**HEATING VENTILATING AND AIR CONDITIONING (HVAC) RECEIVER/DRYER REMOVAL AND INSTALLATION
- (CONTINUED)**

B235201696

Figure 11. Discharge Hose at Receiver/Drier.

5. Connect receiver/drier outlet hose (Figure 11, Item 3) to receiver/drier (Figure 11, Item 1). Do not tighten fitting (Figure 11, Item 2).
6. Add clean PAG oil, equal to amount drained from receiver/drier and receiver/drier outlet hose (Figure 11, Item 3), to other end of hose.

**HEATING VENTILATING AND AIR CONDITIONING (HVAC) RECEIVER/DRIER REMOVAL AND INSTALLATION
- (CONTINUED)****CAUTION**

Avoid contact with heater core fins. Failure to comply may result in damage to heater core.

7. While supporting receiver/drier (Figure 12, Item 2), loosely install receiver/drier with four bolts (Figure 12, Item 1), flat washers, and new lockwashers and tighten securely.

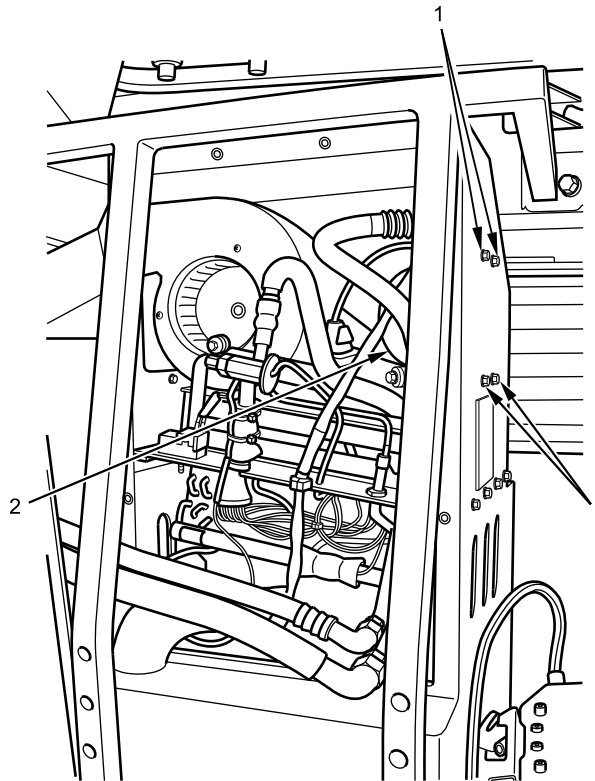

B235203376

Figure 12. Receiver/Drier Mounting Bolts.

8. Connect receiver/drier outlet hose (Figure 13, Item 1) to thermal expansion valve (Figure 13, Item 2) and tighten securely.

HEATING VENTILATING AND AIR CONDITIONING (HVAC) RECEIVER/DRIER REMOVAL AND INSTALLATION - (CONTINUED)

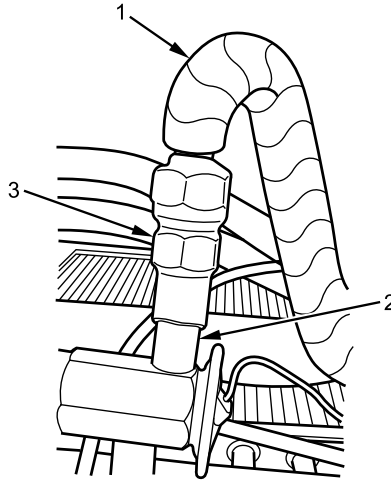

B235201694

Figure 13. Discharge Hose at Thermal Expansion Valve.

9. Tighten receiver/drier clamp bolts (Figure 13, Item 1) and mounting bolts (Figure 12, Item 1) securely.
10. Tighten receiver/drier outlet hose fitting (Figure 11, Item 2) at receiver/drier (Figure 11, Item 1) securely.

NOTE

Align nipple on connector with grooved slot on bracket.

11. Install HVAC high pressure switch harness locknut connector (Figure 14, Item 1) on bracket (Figure 14, Item 4) with nut (Figure 14, Item 3) and tighten securely.

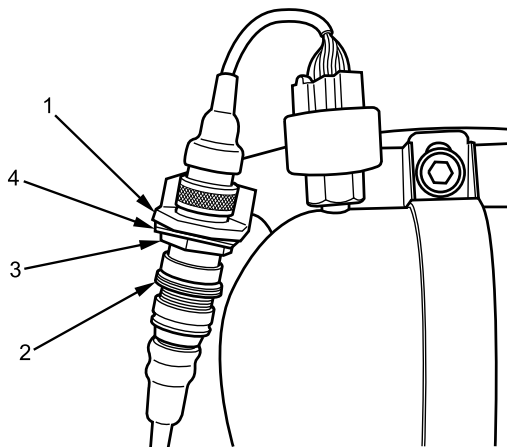

B235201693

Figure 14. Pressure Switch Connection.

12. Connect LSS harness connector (Figure 14, Item 2) to locknut connector (Figure 14, Item 1).
13. Coat new O-rings with PAG oil and install one O-ring on each end of receiver/drier inlet hose (Figure 15, Item 1).

HEATING VENTILATING AND AIR CONDITIONING (HVAC) RECEIVER/DRIER REMOVAL AND INSTALLATION - (CONTINUED)

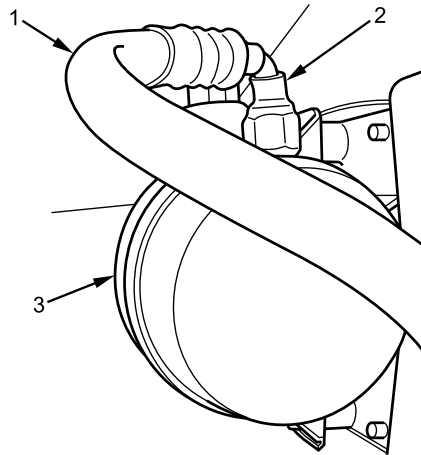

B235201692

Figure 15. Inlet Hose at Receiver/Drier.

14. Connect receiver/drier inlet hose (Figure 15, Item 1) to receiver/drier (Figure 15, Item 3). Do not tighten fitting (Figure 15, Item 2).
15. Add clean PAG oil, equal to amount drained from receiver/drier inlet hose (Figure 16, Item 2), to other end of hose.

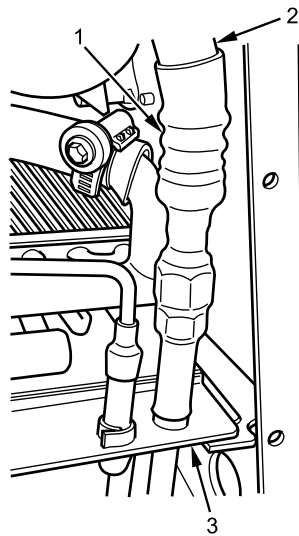

B235201691

Figure 16. Inlet Hose at Evaporator Assembly.

16. Connect receiver/drier inlet hose (Figure 16, Item 2) to evaporator assembly (Figure 16, Item 3) and tighten securely.
17. Tighten receiver/drier inlet hose fitting (Figure 16, Item 2) at receiver/drier (Figure 16, Item 3) securely.

END OF TASK

FOLLOW-ON MAINTENANCE

1. Evacuate and recharge HVAC system (WP 0707).
2. Install HVAC/LSS upper panel (WP 0767).

**HEATING VENTILATING AND AIR CONDITIONING (HVAC) RECEIVER/DRIER REMOVAL AND INSTALLATION
- (CONTINUED)**

3. Remove wheel chocks (TM 9-2355-106-10).

END OF TASK**END OF WORK PACKAGE**

FIELD MAINTENANCE**HEATING VENTILATING AND AIR CONDITIONING (HVAC) MAIN EVAPORATOR ASSEMBLY REMOVAL
AND INSTALLATION**

INITIAL SETUP:**Tools and Special Tools**

General Mechanic's Tool Kit (GMTK)
(WP 0795, Item 37)
Measure, liquid, 2 qt (WP 0795, Item 71)

TM 9-2355-106-23P

WP 0707

WP 0782

Materials/Parts

Wire tags (WP 0794, Item 33)
Faceshield, industrial (WP 0794, Item 16)
Gloves (WP 0794, Item 18)
Lubricating oil (WP 0794, Item 31)
Cable lock strap - (6) (WP 0796, Item 134)
O-ring (WP 0796, Item 35)
O-ring (WP 0796, Item 37)
Lockwasher - (8) (WP 0796, Item 168)

Equipment Condition

Parking brake set (TM 9-2355-106-10)
Transmission set in NEUTRAL (N) (TM
9-2355-106-10)
Engine off (TM 9-2355-106-10)
MAIN POWER switch off (TM 9-2355-106-10)
Wheels chocked (TM 9-2355-106-10)
HVAC/Life Support System (LSS) upper panel
removed (WP 0767)
HVAC heater radiator removed (WP 0760)

ReferencesTM 9-2355-106-10

HEATING VENTILATING AND AIR CONDITIONING (HVAC) MAIN EVAPORATOR ASSEMBLY REMOVAL AND INSTALLATION - (CONTINUED)**WARNING**

The temperature of liquid refrigerant is -20°F (-29°C). Wear full face shield, protective rubberized gloves, and protective clothing when working with refrigerant. If refrigerant contacts skin, remove all contaminated clothing. Treat skin as though it were frostbitten or frozen and seek immediate medical attention. If refrigerant contacts eyes, do not rub them. Flush eyes with cold water for at least 15 minutes to gradually increase temperature above freezing point. Seek immediate medical attention. Failure to comply may result in serious injury or death to personnel.

Do not expose refrigerant containers, empty or full, to open flames or temperatures above 125°F (52°C). Do not discard empty containers where they may be subject to heat from a trash burner; containers may explode. Failure to comply may result in damage to equipment and serious injury or death to personnel.

R-134a refrigerant must not be mixed with air and then pressurized. When mixed with large quantities of air and pressurized, R-134a becomes combustible. Failure to comply may result in damage to equipment and environment, and serious injury or death to personnel.

Federal and state laws require that refrigerant be recovered and recycled. Refrigerant must be recovered from system with authorized recommended equipment before any work can be performed on unit. Always use approved recycling equipment to prevent accidental discharge. Failure to comply may result in damage to equipment and environment, and serious injury or death to personnel.

Refrigerant evaporates very quickly and may displace oxygen in surrounding work area, especially in a small or enclosed area. This can cause suffocation or brain damage. If leak occurs, avoid breathing refrigerant vapor and thoroughly ventilate area before continuing service. If personnel breathe refrigerant vapors, obtain immediate medical assistance. Failure to comply may result in serious injury or death to personnel.

Never open the high side hand valve of the manifold gauge set while HVAC system is operating. If hot, high pressure refrigerant is forced through gauge to refrigerant supply cylinder, which could rupture. Failure to comply may result in damage to equipment and environment, and serious injury or death to personnel.

Do not install or remove air-conditioning testing or charging equipment while engine is running. Wait 30 seconds after engine shutdown to allow high side and low side pressures to equalize. Failure to comply may result in damage to equipment and environment, and serious injury or death to personnel.

Refrigerant becomes a poisonous gas in the presence of heat. Do not smoke or allow any type of flame in immediate area while servicing air conditioning system. Never weld, solder, steam clean, or use excessive heat on any part of the air conditioning system while charged/pressurized. Failure to comply may result in damage to equipment and serious injury or death to personnel.

HEATING VENTILATING AND AIR CONDITIONING (HVAC) MAIN EVAPORATOR ASSEMBLY REMOVAL AND INSTALLATION - (CONTINUED)

Do not check compressor oil level when HVAC system is charged with refrigerant. Never open the high side hand valve of the manifold gauge set while HVAC system is operating. If hot, high pressure refrigerant is forced through gauge to refrigerant supply cylinder, which could rupture. Do not disconnect HVAC lines from compressor. Release of refrigerant may cause damage to equipment or environment and serious injury or death to personnel.

Do not use parts other than those specified for the system being serviced. Failure to comply may result in damage to equipment and serious injury or death to personnel.

Accidental or intentional introduction of liquid contaminants into the environment is a violation of state, federal, and military regulations. Store, install, and dispose of containers in accordance with standard operating procedures. Refer to Army Petroleum, Oil, and Lubricants (POL) (para. 1-8) for information concerning storage, use, and disposal of liquid contaminants. Failure to comply may result in damage to environment and serious injury or death to personnel.

REMOVAL

1. Remove heatshrink tubing (Figure 1, Item 2) from evaporator inlet hose (Figure 1, Item 1) at evaporator inlet hose fitting (Figure 1, Item 3). Discard heatshrink tubing.

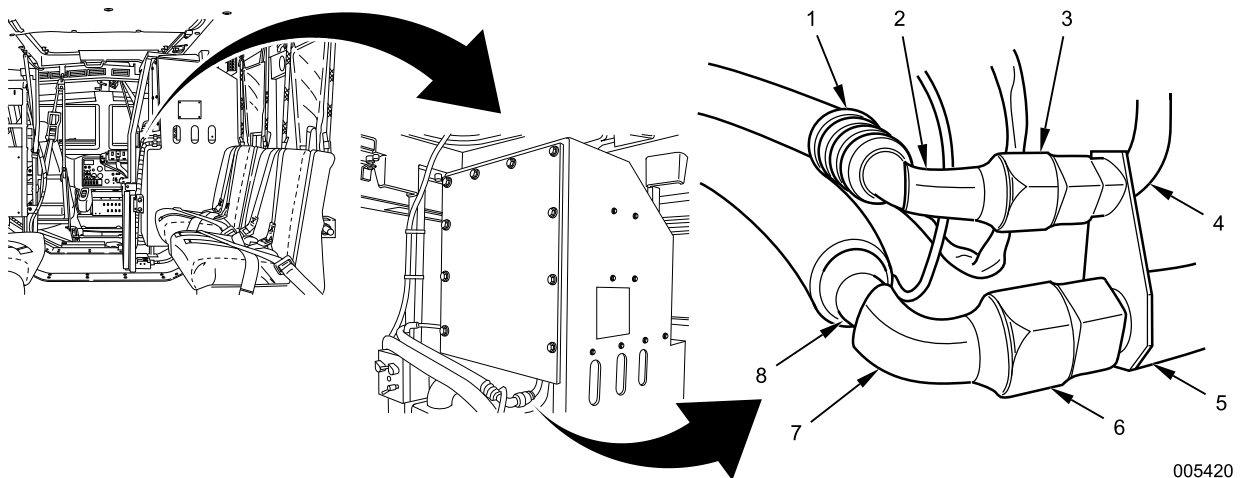
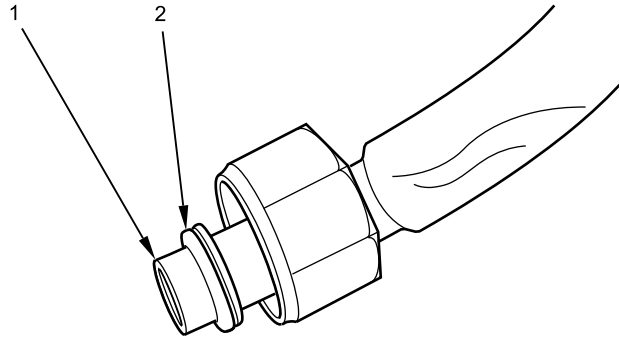

Figure 1. Evaporator Fittings.

2. Disconnect evaporator inlet hose (Figure 1, Item 1) from evaporator inlet (Figure 1, Item 4).
3. Allow PAG oil to drain from evaporator inlet hose (Figure 1, Item 1) into liquid measure.
4. Remove heatshrink tubing (Figure 1, Item 7) from evaporator outlet hose (Figure 1, Item 8) at evaporator outlet hose fitting (Figure 1, Item 6). Discard heatshrink tubing.
5. Disconnect evaporator outlet hose (Figure 1, Item 8) from evaporator outlet (Figure 1, Item 5).
6. Allow PAG oil to drain from evaporator outlet hose (Figure 1, Item 1) into liquid measure.

HEATING VENTILATING AND AIR CONDITIONING (HVAC) MAIN EVAPORATOR ASSEMBLY REMOVAL AND INSTALLATION - (CONTINUED)

7. Remove O-rings (Figure 2, Item 2) from evaporator hose ends (Figure 2, Item 1). Discard O-rings.



B235203067

Figure 2. Evaporator Hose With O-Ring Installed.

NOTE

Identify and label HVAC thermostat wire connections before removing to aid in installation.

8. Remove and discard cable lock straps (Figure 3, Item 2).

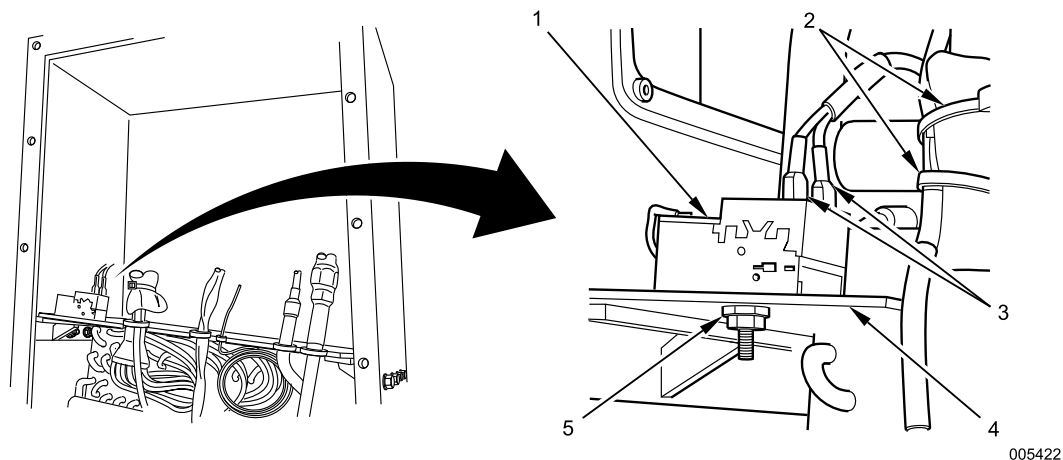

005422

Figure 3. HVAC Thermostat.

9. Disconnect LSS harness connections (Figure 3, Item 3) from HVAC thermostat (Figure 3, Item 1) and set harness aside.
10. Remove nut (Figure 3, Item 5) and HVAC thermostat (Figure 3, Item 1) from evaporator assembly (Figure 3, Item 4).
11. Remove evaporator assembly (Figure 4, Item 1) from mounting brackets (Figure 4, Item 3). Avoid spilling PAG oil.

HEATING VENTILATING AND AIR CONDITIONING (HVAC) MAIN EVAPORATOR ASSEMBLY REMOVAL AND INSTALLATION - (CONTINUED)

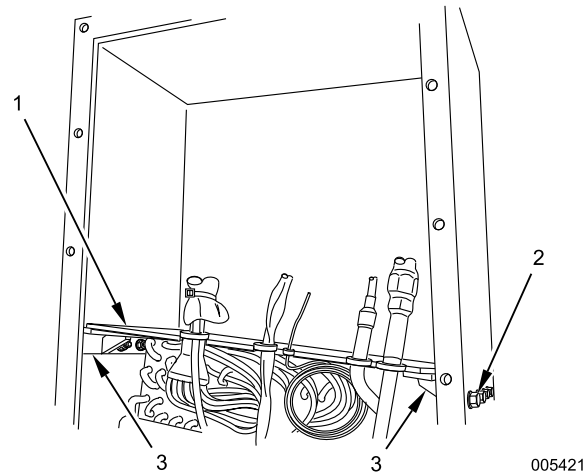

Figure 4. Evaporator Mounting Bracket Bolts.

12. Drain PAG oil from evaporator assembly (Figure 4, Item 1) into measured container.
13. Remove eight evaporator assembly bolts (Figure 4, Item 2), lockwashers, flat washers, and evaporator mounting brackets (Figure 4, Item 3). Discard lockwashers.

END OF TASK

INSTALLATION

1. Install evaporator mounting brackets (Figure 5, Item 3) with eight flat washers, lockwashers, and bolts (Figure 5, Item 2). Tighten mounting bracket bolts securely.

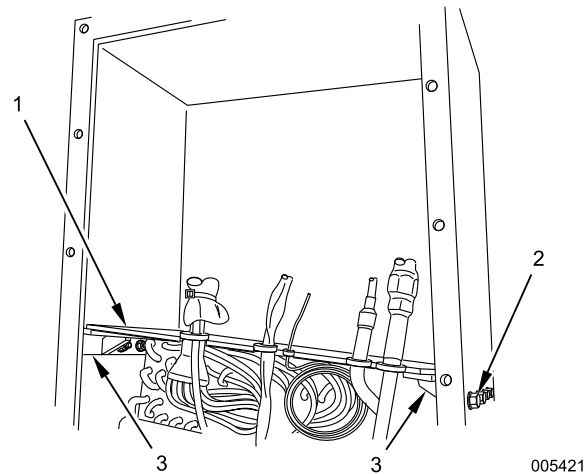

Figure 5. Evaporator Mounting Bracket Bolts.

2. Add clean PAG oil, equal to amount drained from evaporator assembly (Figure 5, Item 1), to evaporator assembly.
3. Position evaporator assembly (Figure 5, Item 1) on evaporator mounting brackets (Figure 5, Item 3). Avoid spilling PAG oil.

HEATING VENTILATING AND AIR CONDITIONING (HVAC) MAIN EVAPORATOR ASSEMBLY REMOVAL AND INSTALLATION - (CONTINUED)

4. Install HVAC thermostat (Figure 6, Item 1) on evaporator assembly (Figure 6, Item 4) with nut (Figure 6, Item 5) and tighten securely.

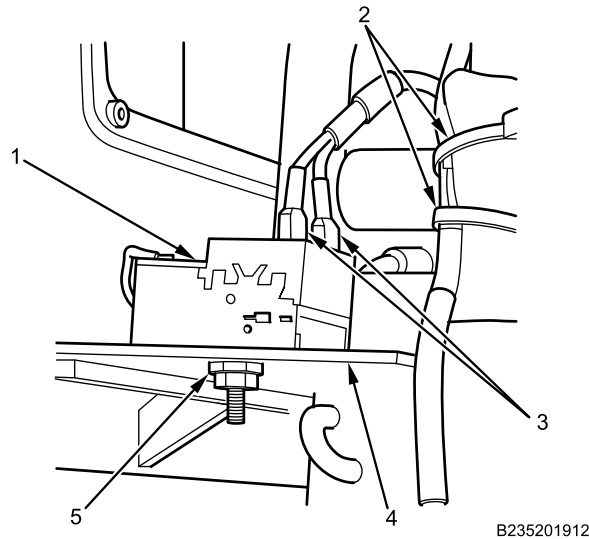
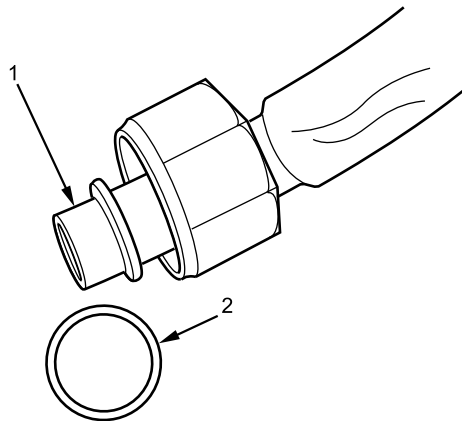

Figure 6. HVAC Thermostat.

5. Connect LSS harness connections (Figure 6, Item 3) to HVAC thermostat (Figure 6, Item 1).
6. Install new cable lock straps (Figure 6, Item 2).
7. Coat new O-rings (Figure 7, Item 2) with PAG oil and install one O-ring on each end of evaporator hose (Figure 7, Item 1).



B235203066

Figure 7. Evaporator Hose With O-Ring Removed

8. Connect evaporator outlet hose (Figure 8, Item 6) to evaporator outlet (Figure 8, Item 4) and tighten evaporator outlet hose fitting (Figure 8, Item 5) securely.

HEATING VENTILATING AND AIR CONDITIONING (HVAC) MAIN EVAPORATOR ASSEMBLY REMOVAL AND INSTALLATION - (CONTINUED)

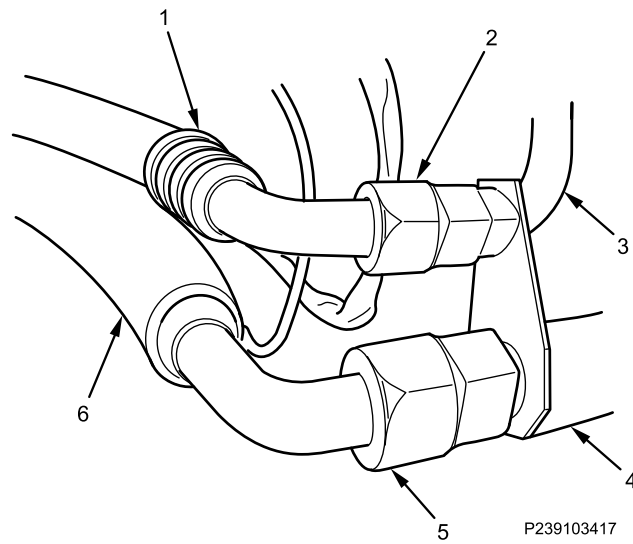

Figure 8. Evaporator Outlet Hose at Evaporator.

9. Connect evaporator inlet hose (Figure 8, Item 1) to evaporator inlet (Figure 8, Item 3) and tighten evaporator inlet hose fitting (Figure 8, Item 2) securely.

END OF TASK

FOLLOW-ON MAINTENANCE

1. Install HVAC heater radiator (WP 0760).
2. Evacuate and recharge HVAC system (WP 0707).
3. Install HVAC/LSS upper panel (WP 0767).
4. Turn MAIN POWER switch on (TM 9-2355-106-10).
5. Start engine (TM 9-2355-106-10).
6. Turn on HVAC/LSS to check for proper operation (TM 9-2355-106-10).
7. Turn off HVAC/LSS (TM 9-2355-106-10).
8. Turn engine off (TM 9-2355-106-10).
9. Turn MAIN POWER switch off (TM 9-2355-106-10).
10. Remove wheel chocks (TM 9-2355-106-10).

END OF TASK

END OF WORK PACKAGE

FIELD MAINTENANCE
HEATING VENTILATING AND AIR CONDITIONING (HVAC) HEATER RADIATOR REMOVAL AND INSTALLATION

INITIAL SETUP:**Tools and Special Tools**

General Mechanic's Tool Kit (GMTK)
(WP 0795, Item 37)
Pan, drain, 5-gal. capacity (WP 0795, Item 75)

WP 0782

Equipment Condition

Parking brake set (TM 9-2355-106-10)
Transmission set in NEUTRAL (N) (TM 9-2355-106-10)
Engine off (TM 9-2355-106-10)
MAIN POWER switch off (TM 9-2355-106-10)
Wheels chocked (TM 9-2355-106-10)
Engine hood open and secured (TM 9-2355-106-10)
HVAC/Life Support System (LSS) upper panel removed (WP 0767)
HVAC blower removed (WP 0766)
HVAC receiver/drier removed (WP 0758)

Materials/Parts

Cable lock strap - (6) (WP 0796, Item 134)
Clamp - (4) (WP 0796, Item 140)
Lockwasher - (6) (WP 0796, Item 168)

References

TM 9-2355-106-10
TM 9-2355-106-23P
WP 0786

REMOVAL**WARNING**

Cooling system components become extremely hot during normal operation. Allow engine to cool completely prior to working on or near radiator. Use extreme care when working in close quarters in engine compartment. Failure to comply may result in serious injury or death to personnel.

Engine hood is extremely heavy and requires two-person lift. Ensure that there is adequate space in front of the vehicle to open hood completely without pinning or pinching personnel between hood and any other structure. Use extreme care when working under hood and make sure it is properly supported. Failure to comply may result in serious injury or death to personnel.

HEATING VENTILATING AND AIR CONDITIONING (HVAC) HEATER RADIATOR REMOVAL AND INSTALLATION - (CONTINUED)

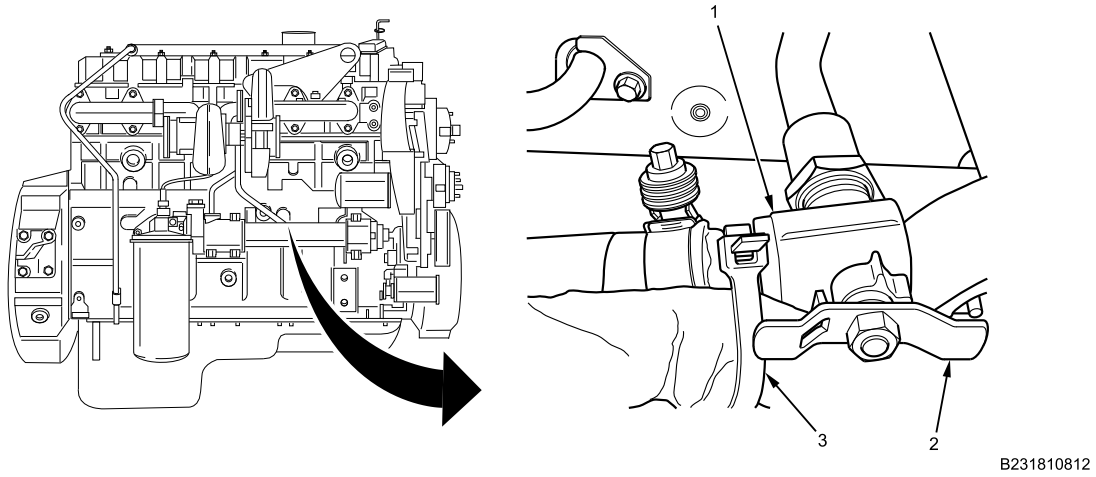

Figure 1. Heater Coolant Engine Outlet Valve.

1. Close outlet valve (Figure 1, Item 1) by turning handle (Figure 1, Item 2) clockwise. Remove and discard cable lock strap if necessary.

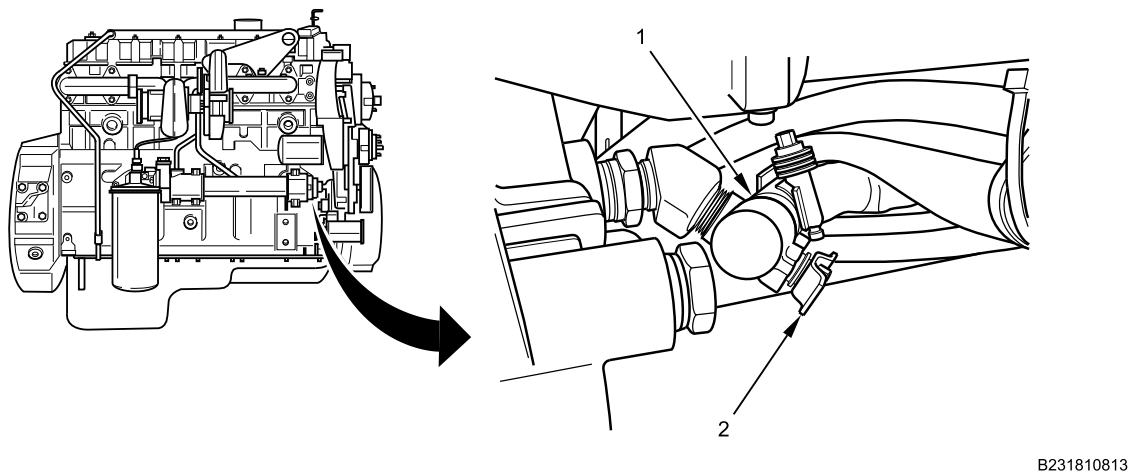
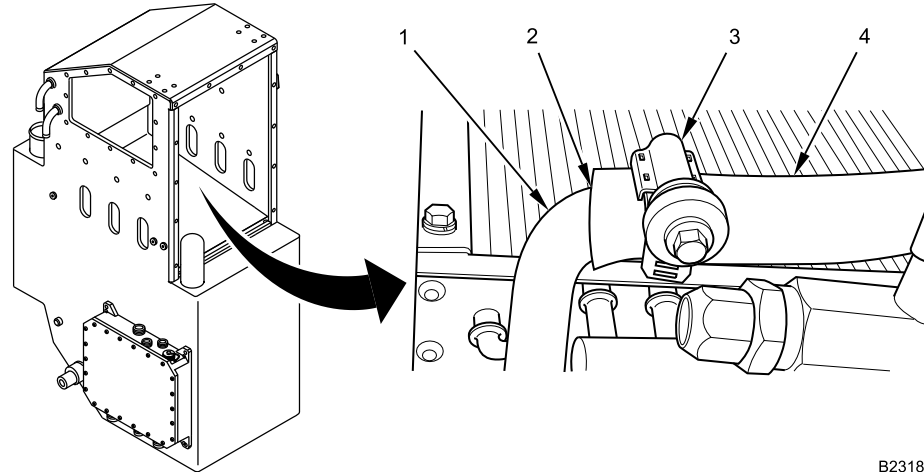

Figure 2. Heater Coolant Engine Inlet Valve.

2. Close inlet valve (Figure 2, Item 1) by turning handle (Figure 2, Item 2) clockwise.

HEATING VENTILATING AND AIR CONDITIONING (HVAC) HEATER RADIATOR REMOVAL AND INSTALLATION - (CONTINUED)



B231810809

Figure 3. Heater Radiator Outlet Fitting.

3. Position drain pan under heater radiator outlet hose connection (Figure 3, Item 2).
4. Loosen clamp (Figure 3, Item 3), disconnect heater radiator outlet hose (Figure 3, Item 4) from heater radiator outlet fitting (Figure 3, Item 1), and allow coolant to drain into drain pan.

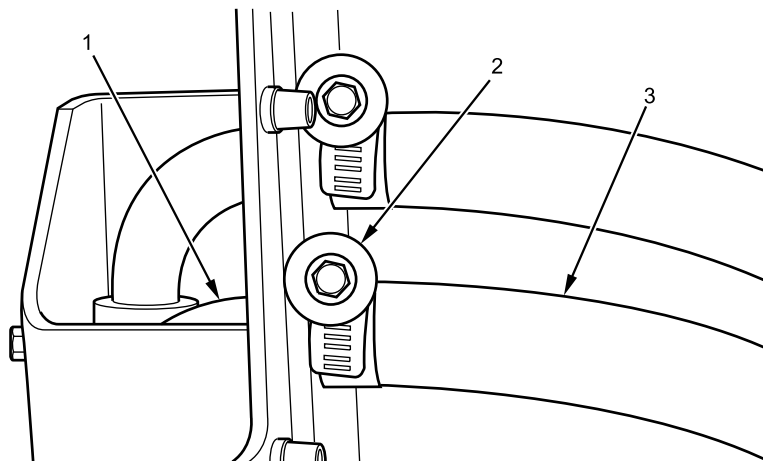

B235201706

Figure 4. Heater Radiator Outlet Hose Inside LSS Box at Panel.

5. Loosen clamp (Figure 4, Item 2), disconnect heater radiator outlet hose (Figure 4, Item 3) from pipe (Figure 4, Item 1) inside LSS box, and remove heater radiator outlet hose.
6. Remove clamps (Figure 4, Item 2) from heater radiator outlet hose (Figure 4, Item 3). Discard clamps.

HEATING VENTILATING AND AIR CONDITIONING (HVAC) HEATER RADIATOR REMOVAL AND INSTALLATION - (CONTINUED)

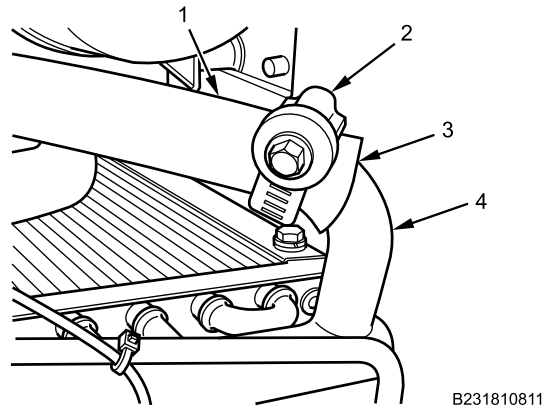

Figure 5. Heater Radiator Inlet Fitting.

7. Position drain pan under heater radiator inlet hose connection (Figure 5, Item 3).
8. Loosen clamp (Figure 5, Item 2), disconnect heater radiator inlet hose (Figure 5, Item 1) from heater radiator inlet fitting (Figure 5, Item 4), and allow coolant to drain into drain pan.

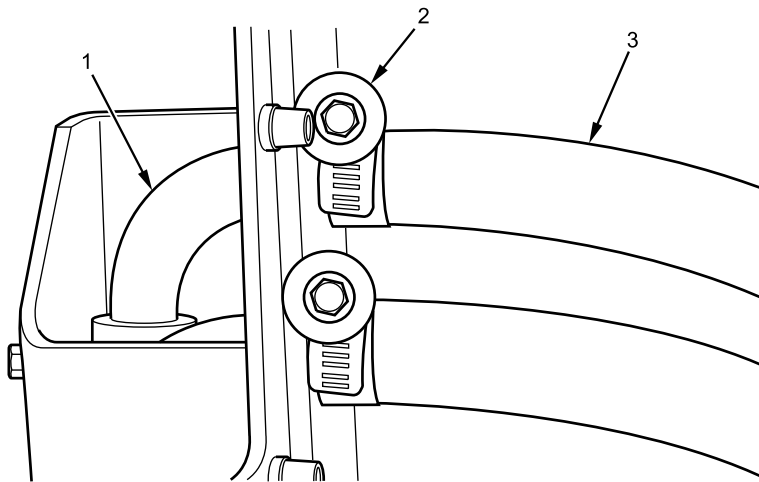
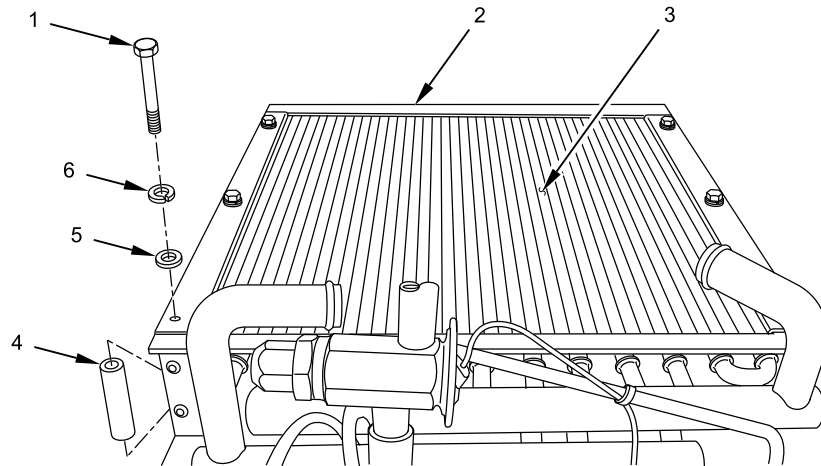

Figure 6. Heater Radiator Inlet Hose Inside LSS Box at Panel.

9. Loosen clamp (Figure 6, Item 2), disconnect heater radiator inlet hose (Figure 6, Item 3) from pipe (Figure 6, Item 1) inside LSS box, and remove heater radiator inlet hose.
10. Remove clamps (Figure 6, Item 2) from heater radiator inlet hose (Figure 6, Item 3). Discard clamps.

HEATING VENTILATING AND AIR CONDITIONING (HVAC) HEATER RADIATOR REMOVAL AND INSTALLATION - (CONTINUED)

B231810810

Figure 7. Heater Radiator.

NOTE

Ensure spacers do not fall out during removal of heater radiator.

Take notice of thermostat/freeze switch sensing probe location. The sensing probe that is part of the thermostat/freeze switch may need to be repositioned. The thermostat/freeze switch will not be removed in this procedure.

11. Remove six bolts (Figure 7, Item 1), lockwashers, (Figure 7, Item 6) and washers (Figure 7, Item 5) from heater radiator perimeter (Figure 7, Item 2). Discard lockwashers.
12. Remove heater radiator (Figure 7, Item 3) from LSS box with spacers (Figure 7, Item 4).

END OF TASK

HEATING VENTILATING AND AIR CONDITIONING (HVAC) HEATER RADIATOR REMOVAL AND INSTALLATION - (CONTINUED)

INSTALLATION

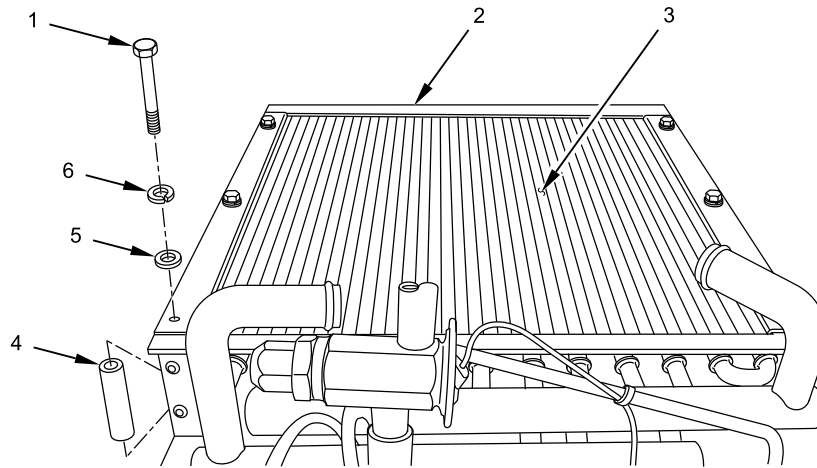

Figure 8. Heater Radiator.

NOTE

Ensure heater radiator spacers are installed prior to heater radiator installation.

Ensure thermostat/freeze switch sensing probe remains in position as noted in removal.

The evaporator core can be moved to aid in installation of heater radiator.

1. Install heater radiator (Figure 8, Item 3) with six bolts (Figure 8, Item 1), new lockwashers (Figure 8, Item 6), washers (Figure 8, Item 5), and spacers (Figure 8, Item 4) on heater radiator perimeter (Figure 8, Item 2) and tighten bolts securely.

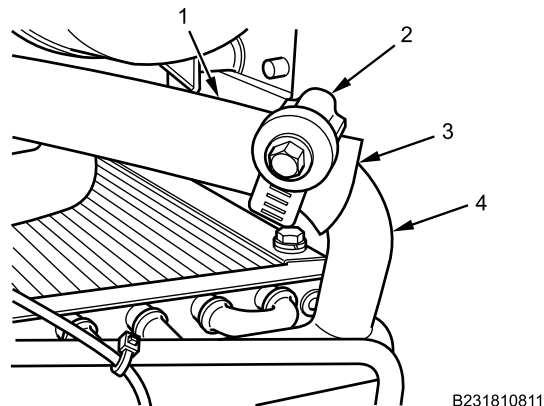
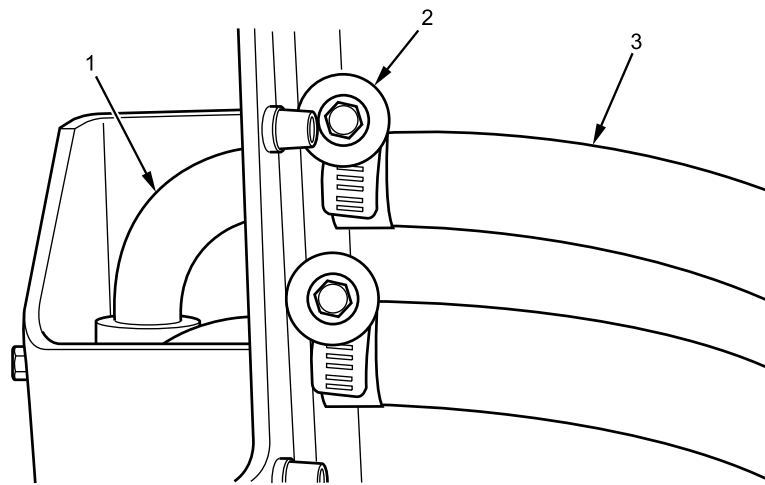

Figure 9. Heater Radiator Inlet Fitting.

2. Position new clamp (Figure 9, Item 2) near heater radiator inlet hose connection (Figure 9, Item 3) at each end of heater radiator inlet hose (Figure 9, Item 1).
3. Connect heater radiator inlet hose (Figure 9, Item 1) to heater radiator inlet fitting (Figure 9, Item 4) with new clamp (Figure 9, Item 2) and tighten securely.

HEATING VENTILATING AND AIR CONDITIONING (HVAC) HEATER RADIATOR REMOVAL AND INSTALLATION - (CONTINUED)



B235201707

Figure 10. Heater Radiator Inlet Hose Inside LSS Box at Panel.

4. Connect heater radiator inlet hose (Figure 10, Item 3) to pipe (Figure 10, Item 1) inside LSS box with new clamp (Figure 10, Item 2) and tighten securely.

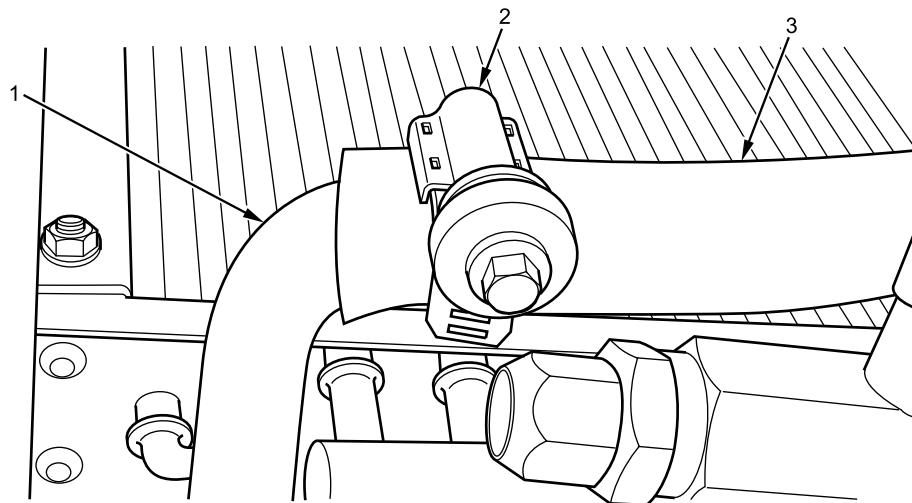

B235201709

Figure 11. Heater Radiator Outlet Fitting.

5. Position new clamp (Figure 11, Item 2) on each end of heater radiator outlet hose (Figure 11, Item 3).
6. Connect heater radiator outlet hose (Figure 11, Item 3) to heater radiator outlet fitting (Figure 11, Item 1) with new clamp (Figure 11, Item 2) and tighten securely.

HEATING VENTILATING AND AIR CONDITIONING (HVAC) HEATER RADIATOR REMOVAL AND INSTALLATION - (CONTINUED)

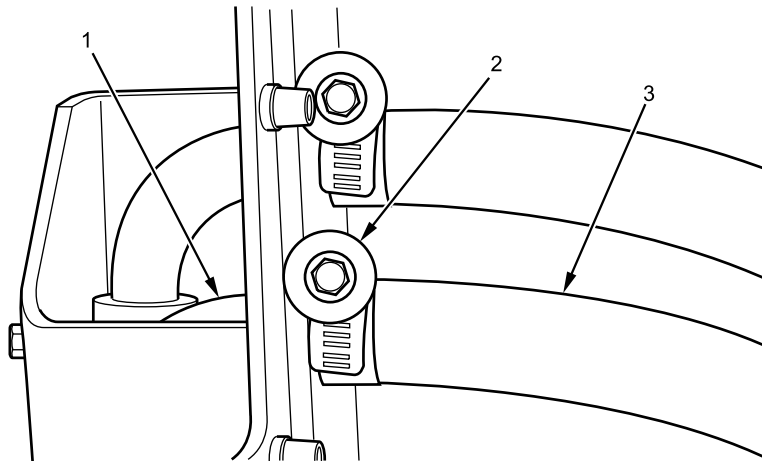

B235201706

Figure 12. Heater Radiator Outlet Hose Inside LSS Box at Panel.

7. Connect heater radiator outlet hose (Figure 12, Item 3) to pipe (Figure 12, Item 1) inside LSS box with clamp (Figure 12, Item 2) and tighten securely.
8. Remove drain pan.

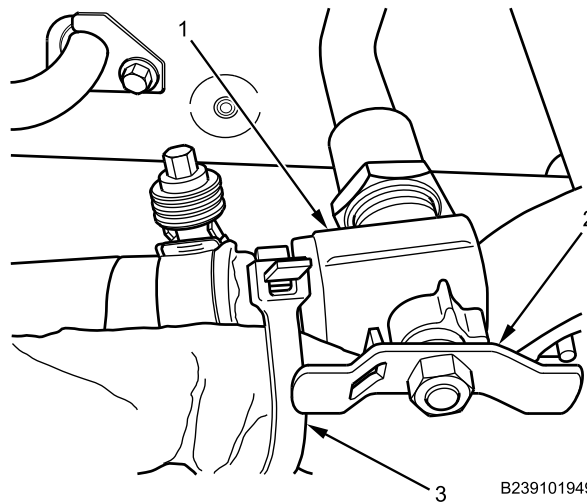

B239101949

Figure 13. Heater Coolant Engine Outlet Valve.

9. Open outlet valve (Figure 13, Item 1) by turning handle (Figure 13, Item 2) counterclockwise. Install new cable lock strap (Figure 13, Item 3) if removed.

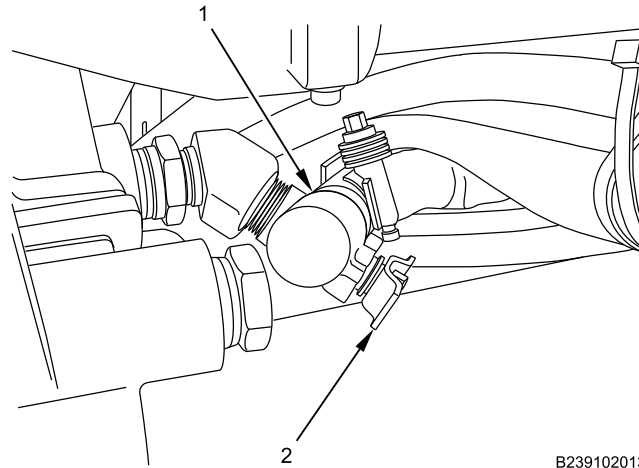
HEATING VENTILATING AND AIR CONDITIONING (HVAC) HEATER RADIATOR REMOVAL AND INSTALLATION - (CONTINUED)

B239102013

Figure 14. Heater Coolant Engine Inlet Valve.

10. Open inlet valve (Figure 14, Item 1) by turning handle (Figure 14, Item 2) counterclockwise.

END OF TASK**FOLLOW-ON MAINTENANCE**

1. Install HVAC receiver/drier (WP 0758).
2. Install HVAC blower (WP 0766).
3. Fill cooling system (WP 0277).
4. Install HVAC/LSS upper panel (WP 0767).
5. Turn MAIN POWER switch on (TM 9-2355-106-10).
6. Start engine (TM 9-2355-106-10).
7. Turn on HVAC/LSS to check for proper operation (TM 9-2355-106-10).
8. Turn off HVAC/LSS (TM 9-2355-106-10).
9. Turn engine off (TM 9-2355-106-10).
10. Turn MAIN POWER switch off (TM 9-2355-106-10).
11. Close and secure engine hood (TM 9-2355-106-10).
12. Remove wheel chocks (TM 9-2355-106-10).

END OF TASK**END OF WORK PACKAGE**

FIELD MAINTENANCE
**HEATING VENTILATING AND AIR CONDITIONING (HVAC)/LIFE SUPPORT SYSTEM (LSS) BOX REMOVAL
AND INSTALLATION**

INITIAL SETUP:**Tools and Special Tools**

General Mechanic's Tool Kit (GMTK)
(WP 0795, Item 37)
Pan, drain, 5-gal. capacity (WP 0795, Item 75)

TM 9-2355-106-23P

WP 0782

Materials/Parts

Antifreeze (WP 0794, Item 5)
Compound (WP 0794, Item 13)
Faceshield, industrial (WP 0794, Item 16)
Gloves (WP 0794, Item 18)
Gloves (WP 0794, Item 19)
Goggles, industrial (WP 0794, Item 20)
Grease (WP 0794, Item 22)
Lubricating oil (WP 0794, Item 30)
Wire tags (WP 0794, Item 49)
Clamp - (2) (WP 0796, Item 45)
O-ring (WP 0796, Item 35)
O-ring (WP 0796, Item 37)
Cable lock strap - (4) (WP 0796, Item 134)

Equipment Condition

Parking brake set (TM 9-2355-106-10)
Transmission set in NEUTRAL (N) (TM
9-2355-106-10)
Engine shut off (TM 9-2355-106-10)
MAIN POWER switch off (TM 9-2355-106-10)
Wheels chocked (TM 9-2355-106-10)
Hood open and secured (TM 9-2355-106-10)
LSS control switch off (TM 9-2355-106-10)
Nuclear, Biological, and Chemical (NBC) filter access
door removed (WP 0762)
HVAC fresh air inlet tube removed (WP 0720)
HVAC/LSS diffuser air duct removed (WP 0755)
Gunner platform/stand removed (WP 0668)
HVAC/LSS operator panel removed (WP 0770)
Climate Control Unit (CCU) box removed (WP 0769)
HVAC water drainage hose removed (WP 0719)
NBC dust tube removed (WP 0721)
HVAC refrigerant recovered (WP 0707)

Personnel Required

Maintainer - (3)

References

TM 9-2355-106-10

HEATING VENTILATING AND AIR CONDITIONING (HVAC)/LIFE SUPPORT SYSTEM (LSS) BOX REMOVAL AND INSTALLATION - (CONTINUED)

WARNING

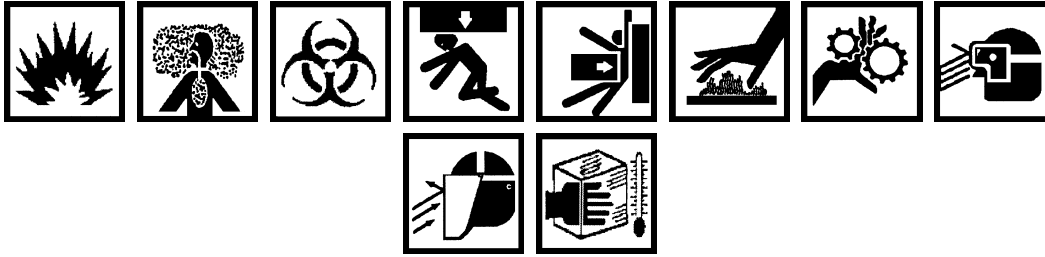

Federal and state laws require that refrigerant be recovered and recycled. Refrigerant must be recovered from system with authorized recommended equipment before any work can be performed on unit. Always use approved recycling equipment to prevent accidental discharge. Failure to comply may result in damage to equipment and environment, and serious injury or death to personnel.

Accidental or intentional introduction of liquid contaminants into the environment is a violation of state, federal, and military regulations. Store, install, and dispose of containers in accordance with standard operating procedures. Refer to Army Petroleum, Oil, and Lubricants (POL) (para. 1-8) for information concerning storage, use, and disposal of liquid contaminants. Failure to comply may result in damage to environment and serious injury or death to personnel.

Refrigerant becomes a poisonous gas in the presence of heat. Do not smoke or allow any type of flame in immediate area while servicing air conditioning system. Never weld, solder, steam clean, or use excessive heat on any part of the air conditioning system while charged/pressurized. Failure to comply may result in damage to equipment and serious injury or death to personnel.

NBC system maintenance procedures require at least two personnel due to risk of medical emergency from possible exposure to NBC agents. Maintenance must be performed by properly trained, authorized personnel with proper safety equipment and protective clothing. Make sure batteries are disconnected and area is well ventilated. Do not smoke or allow open flame near vehicle. Never operate system with cover or panel removed. Failure to comply may result in serious injury or death to personnel.

Engine hood is extremely heavy and requires two-person lift. Ensure that there is adequate space in front of the vehicle to open hood completely without pinning or pinching personnel between hood and any other structure. Use extreme care when working under hood and make sure it is properly supported. Failure to comply may result in serious injury or death to personnel.

Engine components become extremely hot during normal operation. Allow engine to cool completely prior to performing maintenance. Use extreme care when working in close quarters in engine compartment. Stay clear of rotating parts. Wear safety goggles, work gloves, and long sleeves or shop coat. Failure to comply may result in serious injury or death to personnel.

The temperature of liquid refrigerant is -20°F (-29°C). Wear full faceshield, protective rubberized gloves, and protective clothing when working with refrigerant. If refrigerant contacts skin, remove all contaminated clothing. Treat skin as though it were frostbitten or frozen and seek immediate medical attention. If refrigerant contacts eyes, do not rub them. Flush eyes with cold water for at least 15 minutes to gradually increase temperature above freezing point. Seek immediate medical attention. Failure to comply may result in serious injury or death to personnel.

HEATING VENTILATING AND AIR CONDITIONING (HVAC)/LIFE SUPPORT SYSTEM (LSS) BOX REMOVAL AND INSTALLATION - (CONTINUED)**REMOVAL****NOTE**

This procedure applies to either of two heater hoses.

1. Close outlet valve (Figure 1, Item 1) by turning handle (Figure 1, Item 2) clockwise. Remove and discard cable lock strap (Figure 1, Item 3) if necessary.

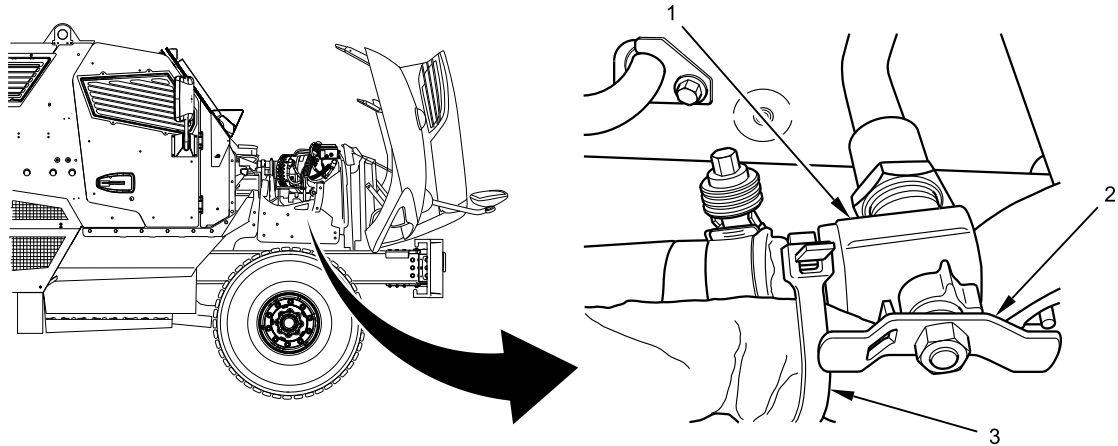

B232210699

Figure 1. Heater Coolant Engine Outlet Valve.

2. Close inlet valve (Figure 2, Item 1) by turning handle (Figure 2, Item 2) clockwise.

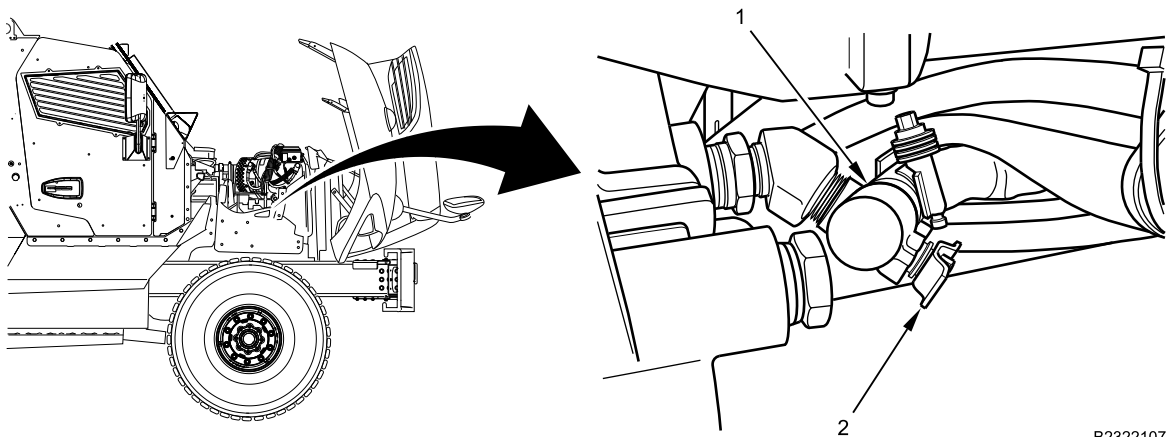

B232210700

Figure 2. Heater Coolant Engine Inlet Valve.

HEATING VENTILATING AND AIR CONDITIONING (HVAC)/LIFE SUPPORT SYSTEM (LSS) BOX REMOVAL AND INSTALLATION - (CONTINUED)

NOTE

Note position of heater hoses with wire tags to aid installation.

3. Position drain pan under heater hoses (Figure 3, Item 2).

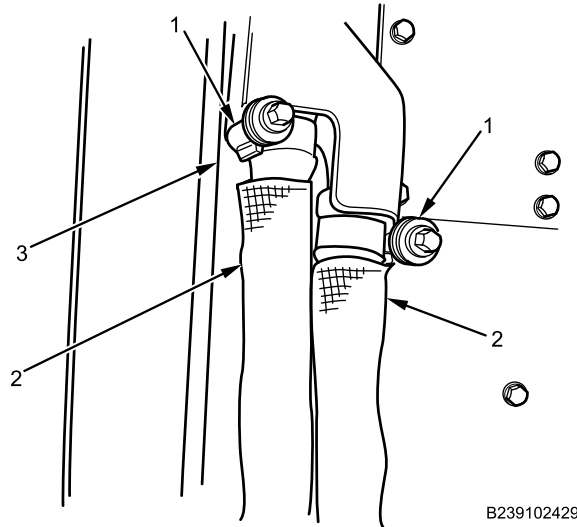

Figure 3. Heater Hoses.

4. Loosen two hose clamps (Figure 3, Item 1) and remove heater hoses (Figure 3, Item 2) from HVAC/LSS box (Figure 3, Item 3). Discard hose clamps.
5. If present, remove heatshrink tubing (Figure 4, Item 2) from evaporator inlet hose (Figure 4, Item 1) at evaporator inlet hose fitting (Figure 4, Item 3). Discard heatshrink tubing.

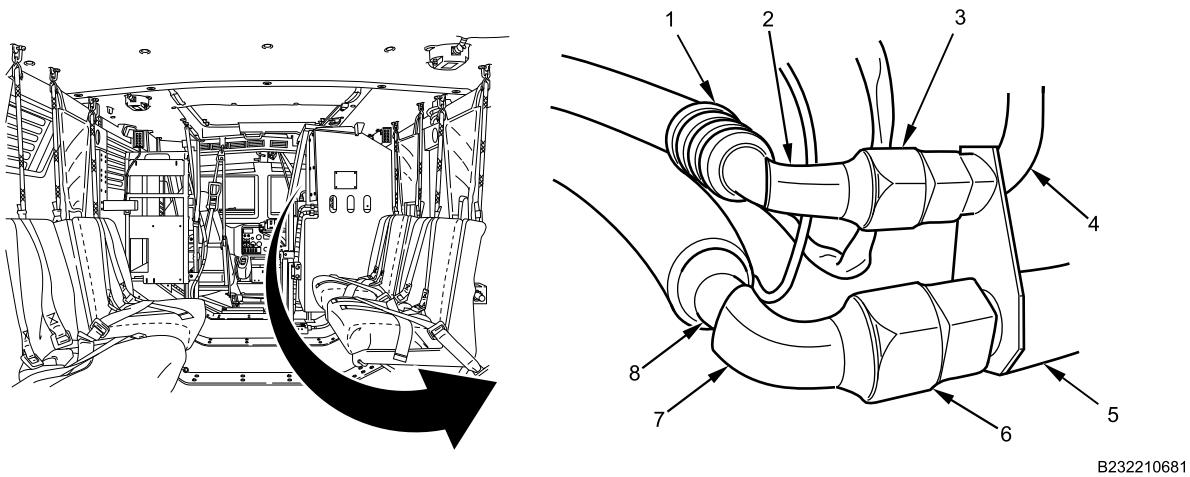
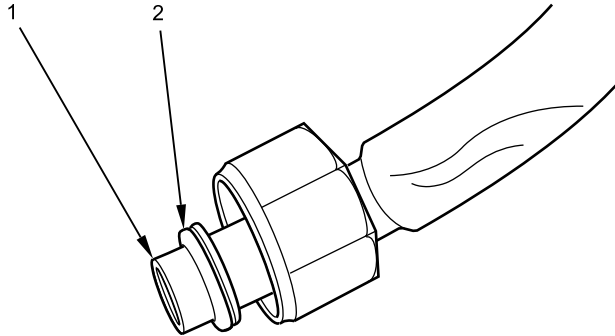

Figure 4. Evaporator Inlet Hose at Evaporator.

HEATING VENTILATING AND AIR CONDITIONING (HVAC)/LIFE SUPPORT SYSTEM (LSS) BOX REMOVAL AND INSTALLATION - (CONTINUED)

6. Disconnect evaporator inlet hose (Figure 4, Item 1) from evaporator inlet (Figure 4, Item 4).
7. If present, remove heatshrink tubing (Figure 4, Item 7) from evaporator outlet hose (Figure 4, Item 8) at evaporator outlet hose fitting (Figure 4, Item 6). Discard heatshrink tubing.
8. Disconnect evaporator outlet hose (Figure 4, Item 8) from evaporator outlet (Figure 4, Item 5).
9. Remove and discard O-rings (Figure 5, Item 2) from evaporator hose ends (Figure 5, Item 1).



B235203067

Figure 5. Evaporator Hose With O-Ring Installed.

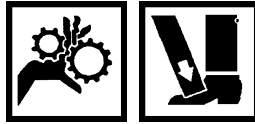
HEATING VENTILATING AND AIR CONDITIONING (HVAC)/LIFE SUPPORT SYSTEM (LSS) BOX REMOVAL AND INSTALLATION - (CONTINUED)**WARNING**

HVAC box is heavy. Do not attempt to lift or support HVAC box without the assistance of two maintainers. HVAC box can fall when removing fasteners. Wear safety goggles and work gloves. Keep feet and hands away from bottom of HVAC box. Failure to comply may result in damage to equipment and serious injury or death to personnel.

10. With two assistants supporting HVAC/LSS box from inside of vehicle, Remove 22 bolts on outside of vehicle (Figure 6, Item 1) securing HVAC/LSS box.

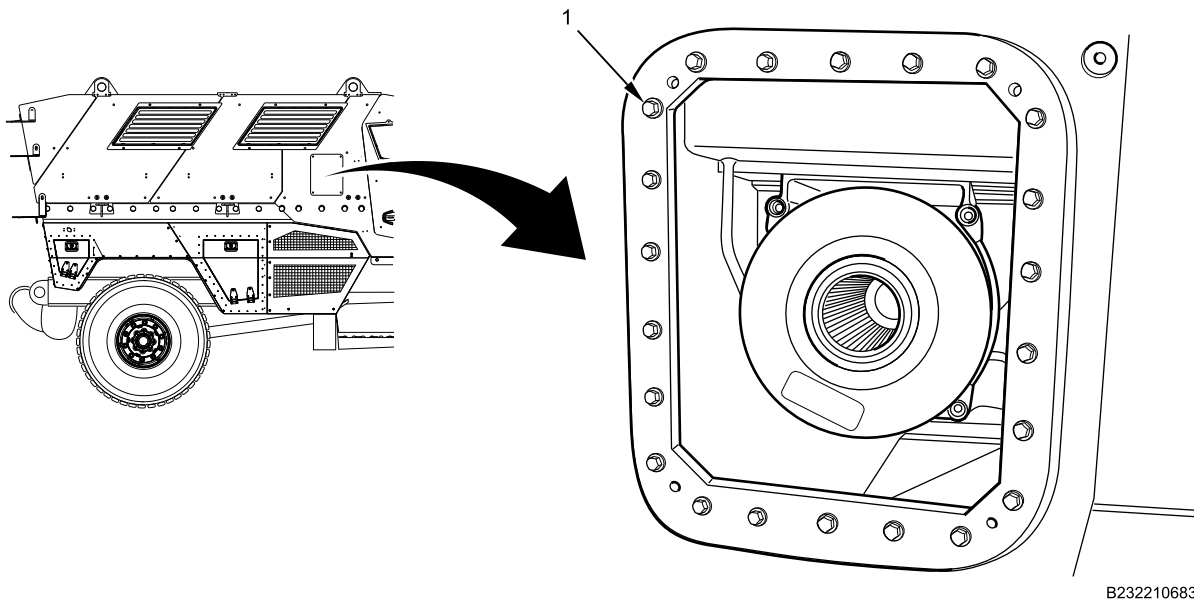

Figure 6. HVAC/LSS Box Mounting.

11. With two assistants, remove HVAC/LSS box.

END OF TASK

HEATING VENTILATING AND AIR CONDITIONING (HVAC)/LIFE SUPPORT SYSTEM (LSS) BOX REMOVAL AND INSTALLATION - (CONTINUED)**INSTALLATION****WARNING**

Corrosion preventive compound is toxic. Use only in well-ventilated area. Do not get in eyes; wear chemical safety goggles and full faceshield when using. Avoid contact with skin and wear rubber or plastic, solvent-resistant gloves. In case of contact, remove contaminated clothing and immediately wash area with soap and water. If compound contacts eyes, flush eyes with large amounts of water for at least 15 minutes and get immediate medical attention. If swallowed, do not induce vomiting; contact a physician immediately. Failure to comply may result in serious injury or death to personnel.

1. Ensure seal (Figure 7, Item 2) is completely seated in groove on outboard side of HVAC box (Figure 7, Item 1).

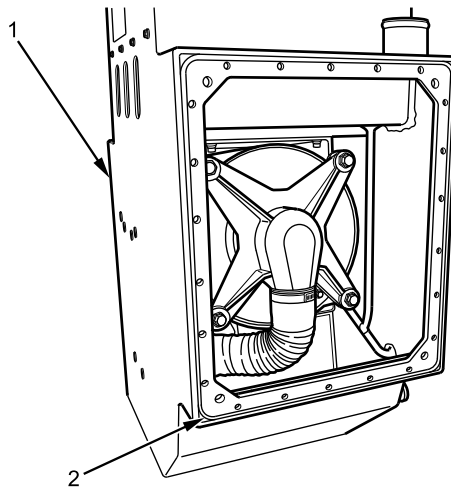

B239103096

Figure 7. HVAC Box Seal.

HEATING VENTILATING AND AIR CONDITIONING (HVAC)/LIFE SUPPORT SYSTEM (LSS) BOX REMOVAL AND INSTALLATION - (CONTINUED)

NOTE

Apply corrosion preventive compound to all HVAC/LSS box bolts.

2. With two assistants aligning HVAC/LSS box holes on inside of vehicle, install 22 HVAC/LSS bolts (Figure 8, Item 1) on outside of vehicle. Tighten bolts securely.

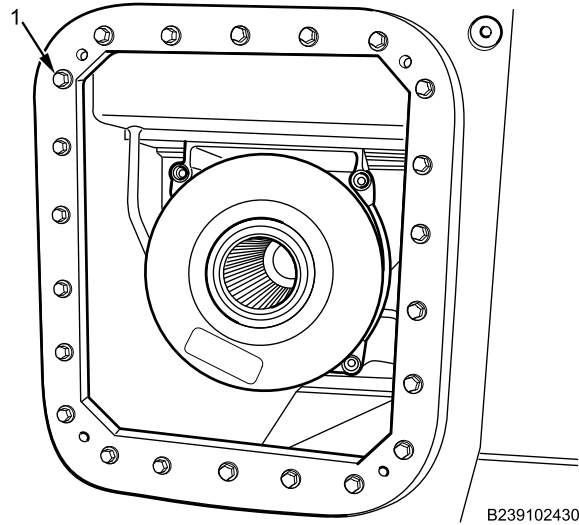
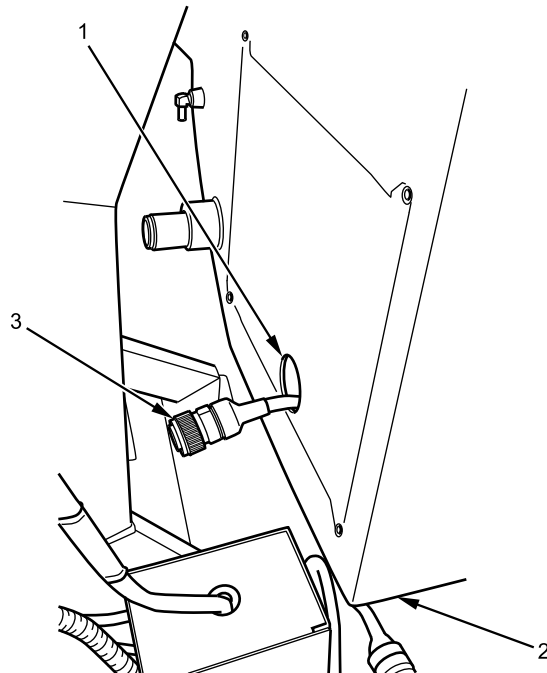

Figure 8. HVAC/LSS Box Mounting.

3. Route HVAC Fresh Air (FA) blower harness (Figure 9, Item 3) from inside NBC filter area through opening (Figure 9, Item 1) in front of HVAC box (Figure 9, Item 2), to aid installation of CCU.



B239103226

Figure 9. Blower Harness Routing.

HEATING VENTILATING AND AIR CONDITIONING (HVAC)/LIFE SUPPORT SYSTEM (LSS) BOX REMOVAL AND INSTALLATION - (CONTINUED)

4. Coat new O-rings (Figure 10, Item 2) with PAG oil and install one O-ring on each end of evaporator hose (Figure 10, Item 1).

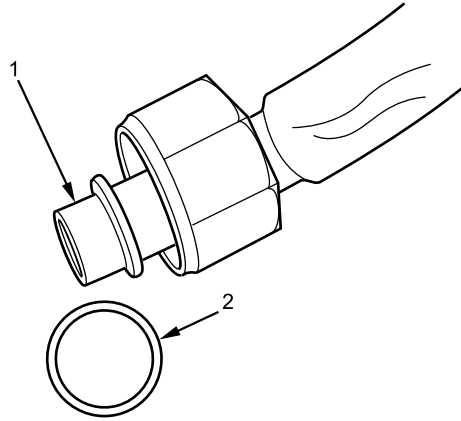

B235203066

Figure 10. Evaporator Hose With O-Ring Removed

5. Connect evaporator outlet hose (Figure 11, Item 6) to evaporator outlet (Figure 11, Item 4) and tighten evaporator outlet hose fitting (Figure 11, Item 5) securely.

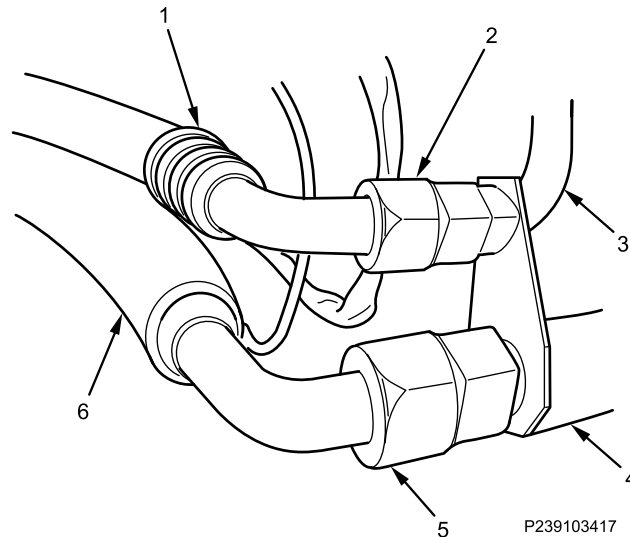

P239103417

Figure 11. Evaporator Outlet Hose at Evaporator.

6. Connect evaporator inlet hose (Figure 11, Item 1) to evaporator inlet (Figure 11, Item 3) and tighten evaporator inlet hose fitting (Figure 11, Item 2) securely.

HEATING VENTILATING AND AIR CONDITIONING (HVAC)/LIFE SUPPORT SYSTEM (LSS) BOX REMOVAL AND INSTALLATION - (CONTINUED)

7. Install two heater hoses (Figure 12, Item 2) on HVAC/LSS box (Figure 12, Item 3) with new hose clamps (Figure 12, Item 1) in positions noted during removal. Tighten hose clamps securely.

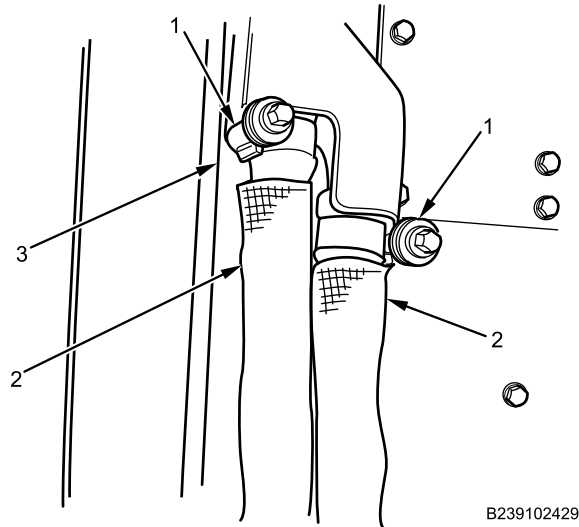

Figure 12. Heater Hoses.

8. Open outlet valve (Figure 13, Item 1) by turning handle (Figure 13, Item 2) counterclockwise. Install new cable lock strap (Figure 13, Item 3) if removed.

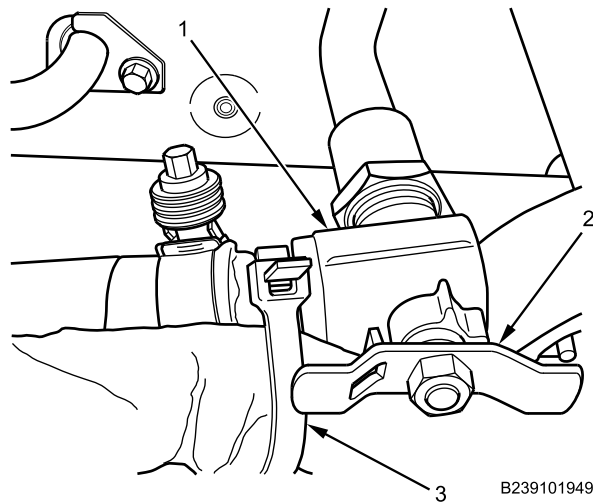
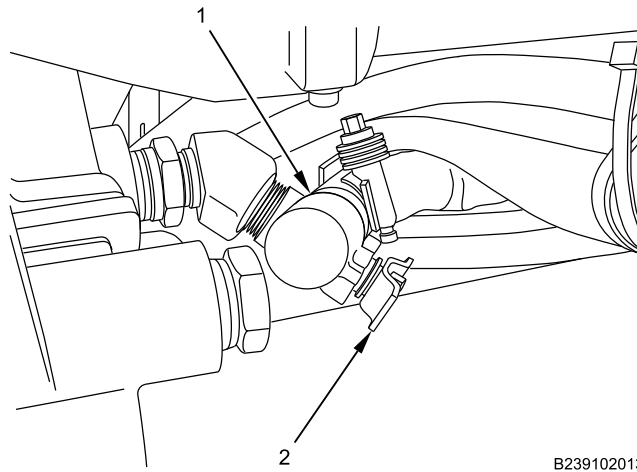

Figure 13. Heater Coolant Engine Outlet Valve.

HEATING VENTILATING AND AIR CONDITIONING (HVAC)/LIFE SUPPORT SYSTEM (LSS) BOX REMOVAL AND INSTALLATION - (CONTINUED)

9. Open inlet valve (Figure 14, Item 1) by turning handle (Figure 14, Item 2) counterclockwise.



B239102013

Figure 14. Heater Coolant Engine Inlet Valve.

10. Remove drain pan.

END OF TASK**FOLLOW-ON MAINTENANCE**

1. Fill coolant system(WP 0277).
2. Evacuate and recharge HVAC system (WP 0707).
3. Install NBC dust tube (WP 0721).
4. Install HVAC water drain hose (WP 0719).
5. Install CCU box (WP 0769).
6. Install HVAC/LSS operator panel (WP 0770).
7. Install gunner platform/stand (WP 0668).
8. Install HVAC/LSS diffuser air duct (WP 0755).
9. Install NBC filter access door (WP 0762).
10. Install HVAC fresh air inlet tube (WP 0720).
11. Close and secure hood (TM 9-2355-106-10).
12. Remove wheel chocks (TM 9-2355-106-10).

END OF TASK**END OF WORK PACKAGE**

FIELD MAINTENANCE
NUCLEAR, BIOLOGICAL, AND CHEMICAL (NBC) FILTER REMOVAL AND INSTALLATION

INITIAL SETUP:**Tools and Special Tools**

General Mechanic's Tool Kit (GMTK)
(WP 0795, Item 37)
Lifting device (Item 67)

TM 9-2355-106-23P

WP 0786

WP 0782

Materials/Parts

Compound (WP 0794, Item 13)
Gloves (WP 0794, Item 28)
Goggles, industrial (WP 0794, Item 20)
Faceshield, industrial (WP 0794, Item 16)
Gloves (WP 0794, Item 18)
Lockwasher - (4) (WP 0796, Item 173)

Equipment Condition

Parking brake set (TM 9-2355-106-10)
Transmission set in NEUTRAL (N) (TM
9-2355-106-10)
Engine off (TM 9-2355-106-10)
MAIN POWER switch off (TM 9-2355-106-10)
Wheels chocked (TM 9-2355-106-10)
Life Support System (LSS) control switch off (TM
9-2355-106-10)
Exterior body armor right front panel removed
(WP 0629)

Personnel Required

Maintainer - (2)

References

TM 9-2355-106-10

WARNING

NBC system maintenance procedures require at least two personnel due to risk of medical emergency from possible exposure to NBC agents. Maintenance must be performed by properly trained, authorized personnel with proper safety equipment and protective clothing. Make sure batteries are disconnected and area is well ventilated. Do not smoke or allow open flame near vehicle. Never operate system with cover or panel removed. Failure to comply may result in serious injury or death to personnel.

Armor parts are heavy. Use care when removing or installing. Do not attempt to lift without an assistant and lifting device. Wear gloves. Failure to comply may result in serious injury or death to personnel.

NUCLEAR, BIOLOGICAL, AND CHEMICAL (NBC) FILTER REMOVAL AND INSTALLATION - (CONTINUED)

REMOVAL

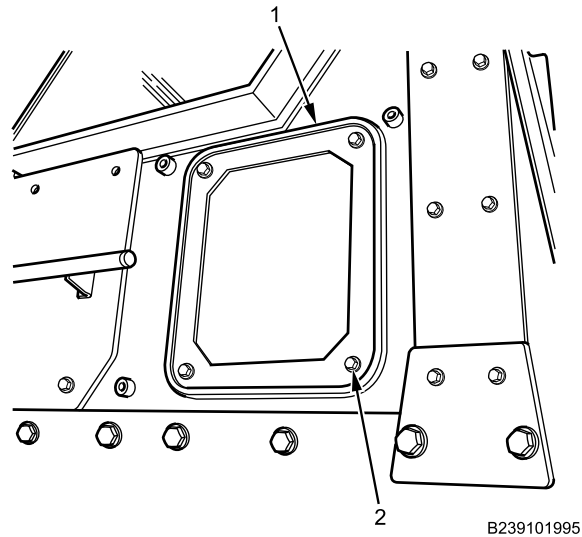

Figure 1. NBC Access Door.

1. Remove four bolts (Figure 1, Item 2) and flat washers from NBC access door (Figure 1, Item 1) and remove access door.

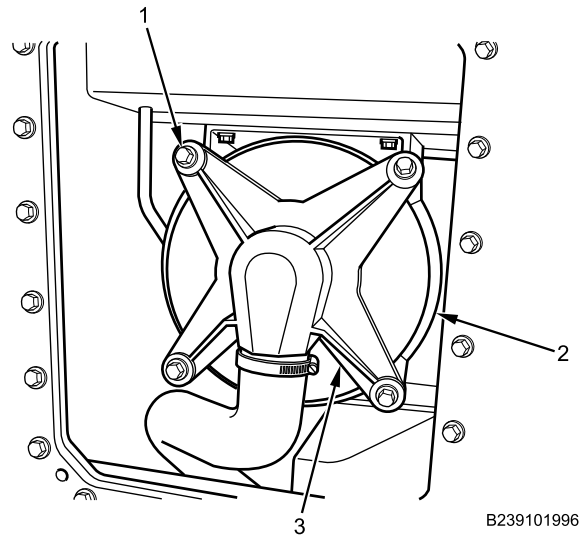

Figure 2. NBC Filter Cover.

2. Remove four bolts (Figure 2, Item 1) and lockwashers from NBC filter cover (Figure 2, Item 3). Discard lockwashers.
3. Remove NBC filter cover (Figure 2, Item 3) from NBC filter housing (Figure 2, Item 2).

NUCLEAR, BIOLOGICAL, AND CHEMICAL (NBC) FILTER REMOVAL AND INSTALLATION - (CONTINUED)

Figure 3. NBC Filter in NBC Filter Housing.

4. Remove NBC filter (Figure 3, Item 1) from NBC filter housing (Figure 3, Item 2).

END OF TASK**INSTALLATION**

Figure 4. NBC Filter Installation.

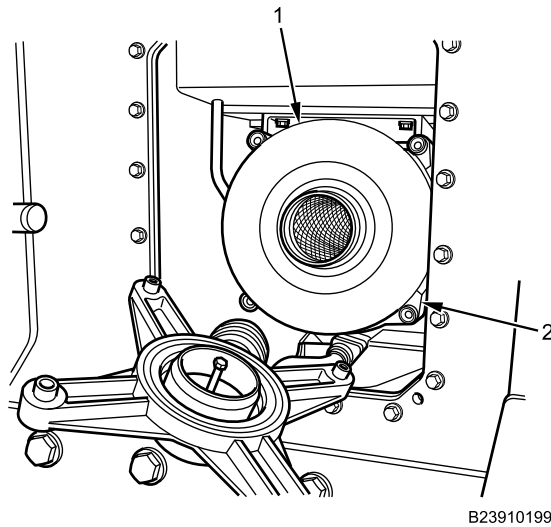
1. Insert NBC filter (Figure 4, Item 1) inside NBC filter housing (Figure 4, Item 2), with directional arrow pointed toward interior of vehicle.

NUCLEAR, BIOLOGICAL, AND CHEMICAL (NBC) FILTER REMOVAL AND INSTALLATION - (CONTINUED)

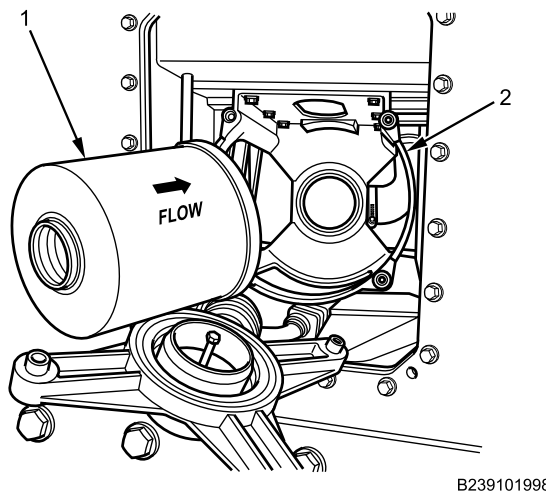
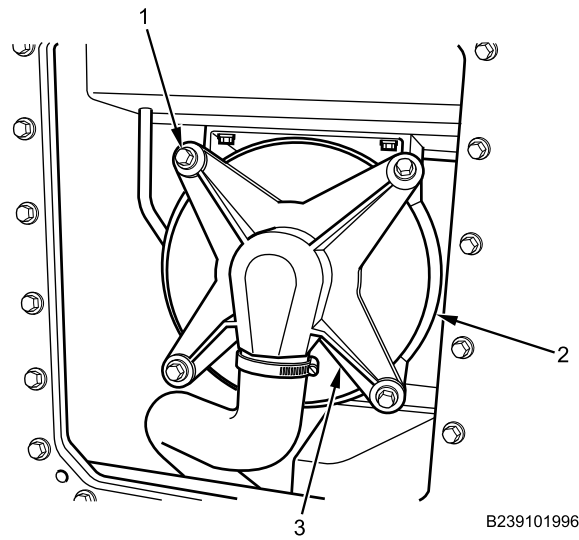

Figure 5. NBC Filter Cover.

2. Install NBC filter cover (Figure 5, Item 3) on NBC filter housing (Figure 5, Item 2) with four bolts (Figure 5, Item 1) and new lockwashers and tighten securely.

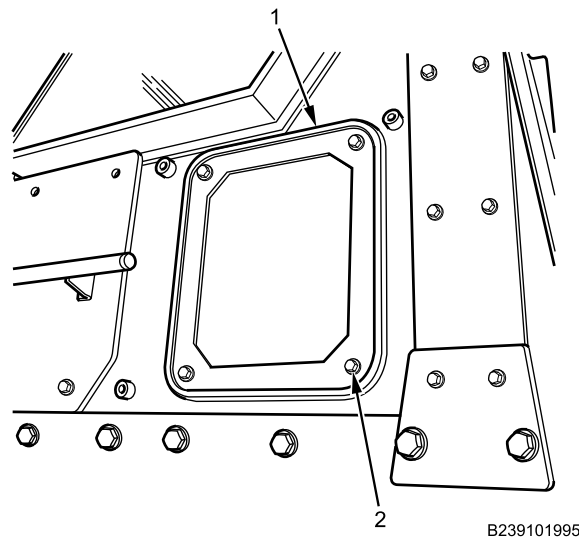

Figure 6. NBC Access Door.

NUCLEAR, BIOLOGICAL, AND CHEMICAL (NBC) FILTER REMOVAL AND INSTALLATION - (CONTINUED)**WARNING**

Corrosion preventive compound is toxic. Use only in well-ventilated area. Do not get in eyes; wear chemical safety goggles and full-face shield when using. Avoid contact with skin and wear rubber or plastic, solvent-resistant gloves. In case of contact, remove contaminated clothing and immediately wash area with soap and water. If compound contacts eyes, flush eyes with large amounts of water for at least 15 minutes and get immediate medical attention. If swallowed, do not induce vomiting; contact a physician immediately. Failure to comply may result in serious injury or death to personnel.

3. Apply corrosion preventive compound to four bolts (Figure 6, Item 2).
4. Install NBC access door (Figure 6, Item 1) with four bolts (Figure 6, Item 2) and flat washers and tighten securely.

END OF TASK**FOLLOW-ON MAINTENANCE**

1. Turn MAIN POWER switch on (TM 9-2355-106-10).
2. Start engine (TM 9-2355-106-10).
3. Close all doors and hatches securely (TM 9-2355-106-10).
4. Turn on Heating Ventilation and Air Conditioning (HVAC)/LSS to verify proper cabin pressure (TM 9-2355-106-10).
5. Turn off HVAC/LSS (TM 9-2355-106-10).
6. Turn engine off (TM 9-2355-106-10).
7. Turn MAIN POWER switch off (TM 9-2355-106-10).
8. Install exterior body armor right front panel (WP 0629).
9. Remove wheel chocks (TM 9-2355-106-10).

END OF TASK**END OF WORK PACKAGE**

FIELD MAINTENANCE**NUCLEAR, BIOLOGICAL, AND CHEMICAL (NBC) FILTER COVER AND HOUSING REMOVAL AND INSTALLATION**

INITIAL SETUP:**Tools and Special Tools**

General Mechanic's Tool Kit (GMTK)
(WP 0795, Item 37)

Materials/Parts

Lockwasher - (6) (WP 0796, Item 168)

Personnel Required

Maintainer - (2)

References

TM 9-2355-106-10
TM 9-2355-106-23P
WP 0786
WP 0782

Equipment Condition

Parking brake set (TM 9-2355-106-10)
Transmission set in NEUTRAL (N) (TM 9-2355-106-10)
Engine off (TM 9-2355-106-10)
MAIN POWER switch off (TM 9-2355-106-10)
Wheels chocked (TM 9-2355-106-10)
Heating Ventilating and Air Conditioning/Life Support System (HVAC/LSS) control switch off (TM 9-2355-106-10)
Right side exterior body armor front panel removed (WP 0633)
NBC filter removed (WP 0762)

WARNING

NBC system maintenance procedures require at least two personnel due to risk of medical emergency from possible exposure to NBC agents. Maintenance must be performed by properly trained, authorized personnel with proper safety equipment and protective clothing. Make sure batteries are disconnected and area is well ventilated. Do not smoke or allow open flame near vehicle. Never operate system with cover or panel removed. Failure to comply may result in serious injury or death to personnel.

NUCLEAR, BIOLOGICAL, AND CHEMICAL (NBC) FILTER COVER AND HOUSING REMOVAL AND INSTALLATION - (CONTINUED)

REMOVAL

1. Loosen hose clamp (Figure 1, Item 4) and remove NBC filter cover (Figure 1, Item 5) from NBC filter inlet tube (Figure 1, Item 1).

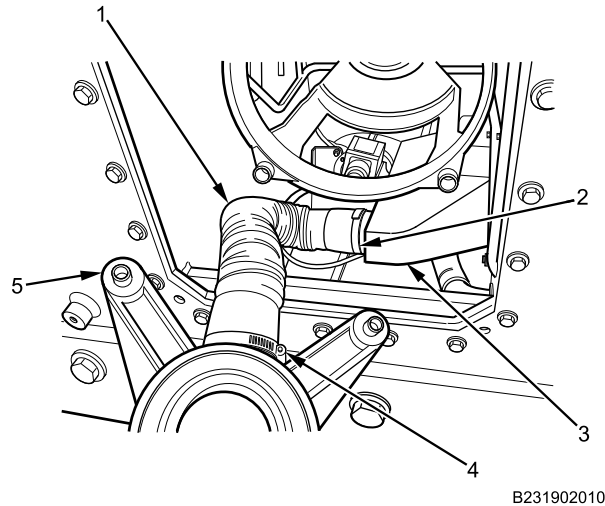

Figure 1. NBC Filter Cover.

2. Loosen hose clamp (Figure 1, Item 2) and remove NBC filter inlet tube (Figure 1, Item 1) from NBC particle separator filter (Figure 1, Item 3).
3. Loosen hose clamp (Figure 2, Item 4).

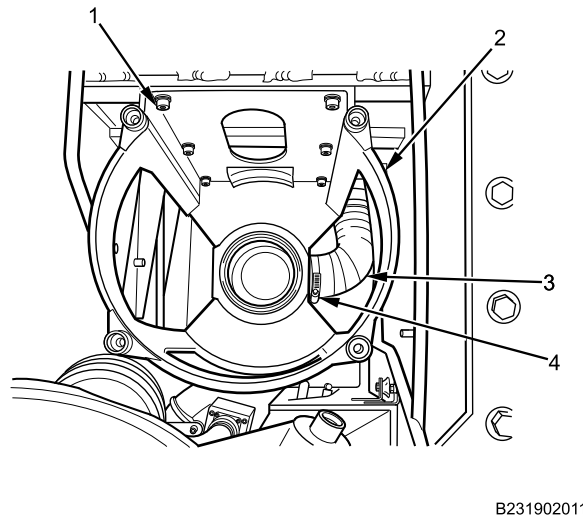

Figure 2. NBC Filter Housing.

4. Remove six allen head bolts (Figure 2, Item 1), lockwashers, and flat washers from NBC filter housing (Figure 2, Item 2). Discard lockwashers.
5. Remove NBC filter housing (Figure 2, Item 2) from NBC filter outlet tube (Figure 2, Item 3).
6. Remove NBC filter housing (Figure 2, Item 2).
7. Loosen hose clamp (Figure 3, Item 1) and remove NBC filter outlet tube (Figure 3, Item 3) from Heating Ventilating and Air Conditioning (HVAC) system inlet tube (Figure 3, Item 2).

NUCLEAR, BIOLOGICAL, AND CHEMICAL (NBC) FILTER COVER AND HOUSING REMOVAL AND INSTALLATION - (CONTINUED)

Figure 3. NBC Filter Outlet Tube.

8. Remove two hose clamps (Figure 3, Item 1) from NBC filter outlet tube (Figure 3, Item 3).

END OF TASK**INSTALLATION**

1. Install NBC filter outlet tube (Figure 4, Item 3) on HVAC system inlet tube (Figure 4, Item 2) with hose clamp (Figure 4, Item 1) and tighten securely.

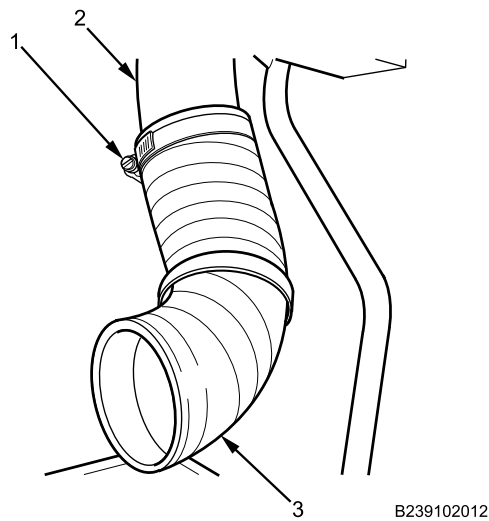
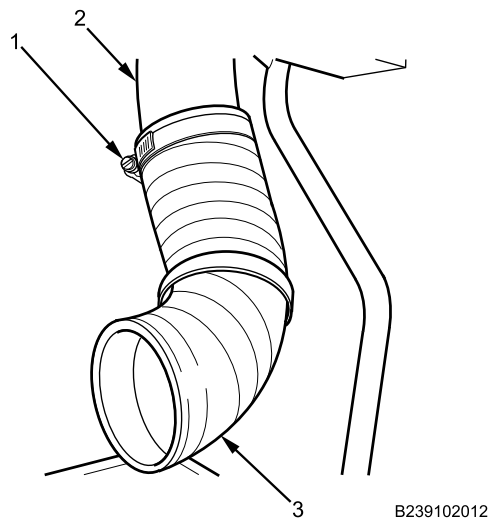
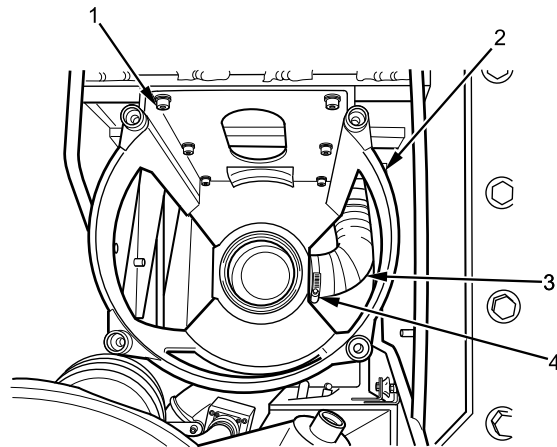

Figure 4. NBC Filter Outlet Tube.

2. Install NBC filter housing (Figure 5, Item 2) on NBC filter outlet tube (Figure 5, Item 3) with hose clamp (Figure 5, Item 4) and tighten securely.

NUCLEAR, BIOLOGICAL, AND CHEMICAL (NBC) FILTER COVER AND HOUSING REMOVAL AND INSTALLATION - (CONTINUED)



B231902011

Figure 5. NBC Filter Housing.

3. Install six allen head bolts (Figure 5, Item 1), flat washers, and new lockwashers on NBC filter housing (Figure 5, Item 2) and tighten securely.
4. Position two hose clamps (Figure 6, Item 2 and 4) on NBC filter inlet tube (Figure 6, Item 1).

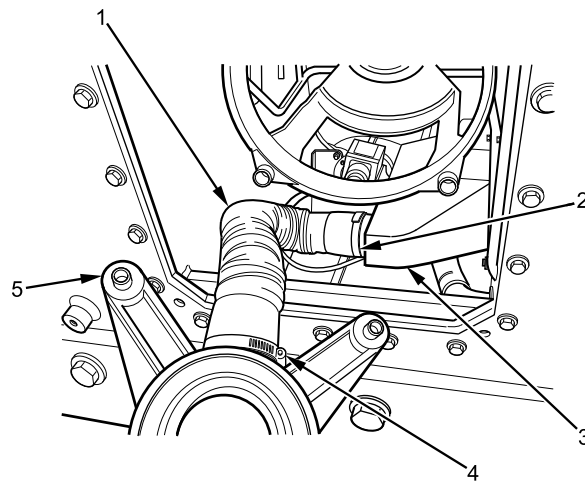

B231902010

Figure 6. NBC Filter Cover.

5. Install NBC filter inlet tube (Figure 6, Item 1) on NBC particle separator filter (Figure 6, Item 3) and tighten hose clamp (Figure 6, Item 2) securely.
6. Install NBC filter cover (Figure 6, Item 5) on NBC filter inlet tube (Figure 6, Item 1) and tighten hose clamp (Figure 6, Item 4) securely.

END OF TASK

NUCLEAR, BIOLOGICAL, AND CHEMICAL (NBC) FILTER COVER AND HOUSING REMOVAL AND INSTALLATION - (CONTINUED)**FOLLOW-ON MAINTENANCE**

1. Install NBC filter (WP 0762).
2. Turn MAIN POWER switch on (TM 9-2355-106-10).
3. Start engine (TM 9-2355-106-10).
4. Close all doors and hatches securely (TM 9-2355-106-10).
5. Turn on HVAC/LSS to verify proper cabin pressure (TM 9-2355-106-10).
6. Turn off HVAC/LSS (TM 9-2355-106-10).
7. Turn engine off (TM 9-2355-106-10).
8. Turn MAIN POWER switch off (TM 9-2355-106-10).
9. Install right side exterior body armor front panel (WP 0633).
10. Remove wheel chocks (TM 9-2355-106-10).

END OF TASK**END OF WORK PACKAGE**

FIELD MAINTENANCE
NUCLEAR, BIOLOGICAL, AND CHEMICAL (NBC) PARTICLE SEPARATOR FILTER REMOVAL AND INSTALLATION

INITIAL SETUP:**Tools and Special Tools**

General Mechanic's Tool Kit (GMTK)
(WP 0795, Item 37)

Transmission set in NEUTRAL (N) (TM 9-2355-106-10)

Engine off (TM 9-2355-106-10)

MAIN POWER switch off (TM 9-2355-106-10)

Wheels chocked (TM 9-2355-106-10)

Life Support System (LSS) control switch off (TM 9-2355-106-10)

Materials/Parts

Lockwashers - (3) (WP 0796, Item 168)

Exterior body armor right front panel removed
(WP 0629)

References**Equipment Condition**

Parking brake set (TM 9-2355-106-10)

NBC filter removed (WP 0762)

NBC filter cover and housing removed (WP 0763)

WARNING

NBC system maintenance procedures require at least two personnel due to risk of medical emergency from possible exposure to NBC agents. Maintenance must be performed by properly trained, authorized personnel with proper safety equipment and protective clothing. Make sure batteries are disconnected and area is well ventilated. Do not smoke or allow open flame near vehicle. Never operate system with cover or panel removed. Failure to comply may result in serious injury or death to personnel.

NUCLEAR, BIOLOGICAL, AND CHEMICAL (NBC) PARTICLE SEPARATOR FILTER REMOVAL AND INSTALLATION - (CONTINUED)

REMOVAL

1. Loosen two hose clamps (Figure 1, Item 2 and 5).

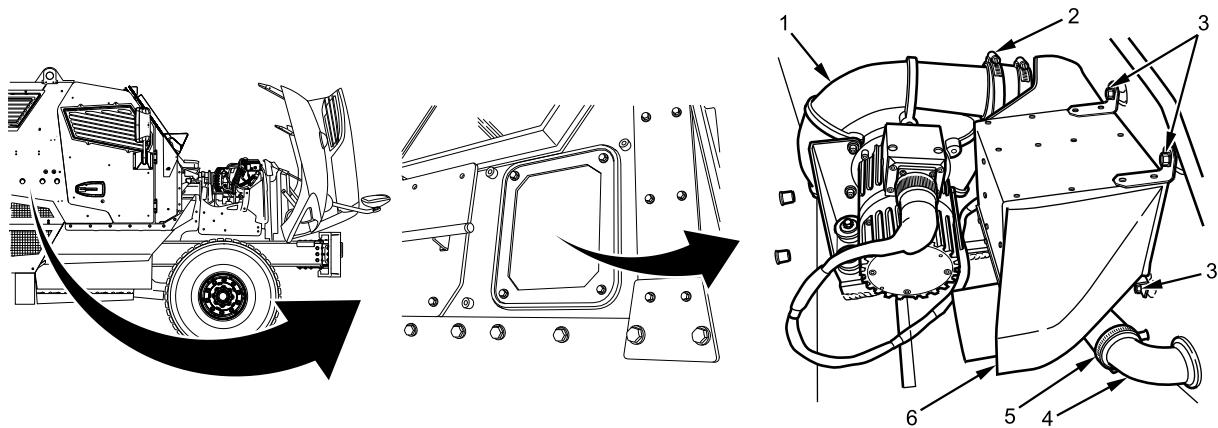

B231810806

Figure 1. NBC Particle Separator Filter Mounting.

2. Remove three bolts (Figure 1, Item 3), flat washers, and lockwashers from NBC particle separator filter assembly (Figure 1, Item 6). Discard lockwashers.
3. Remove particle separator filter assembly (Figure 1, Item 6) from main blower motor (Figure 1, Item 1) and dust tube (Figure 1, Item 4).

NOTE

Note position and orientation of NBC particle separator filter tubes prior to removal to aid in installation.

4. Remove four hose clamps (Figure 2, Item 2, 3, 5, and 6) from NBC particle separator filter assembly (Figure 2, Item 1).

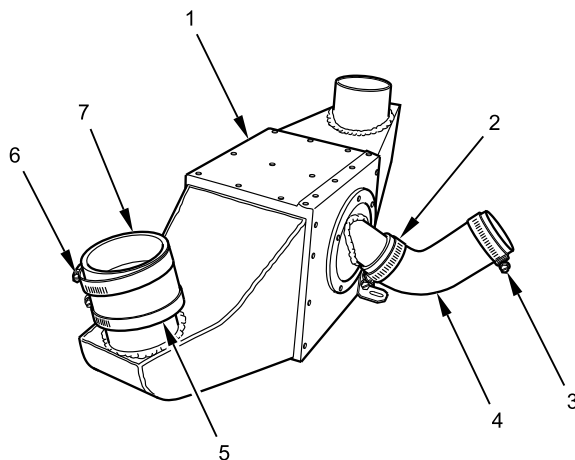

B239102017

Figure 2. NBC Particle Separator Filter.

5. Remove main blower outlet tube (Figure 2, Item 7) from NBC particle separator filter assembly (Figure 2, Item 1).

NUCLEAR, BIOLOGICAL, AND CHEMICAL (NBC) PARTICLE SEPARATOR FILTER REMOVAL AND INSTALLATION - (CONTINUED)

6. Remove dust outlet tube (Figure 2, Item 4) from NBC particle separator filter assembly (Figure 2, Item 1).

END OF TASK**INSTALLATION**

1. Position dust outlet tube (Figure 3, Item 4) on NBC particle separator filter assembly (Figure 3, Item 1) as noted during removal.

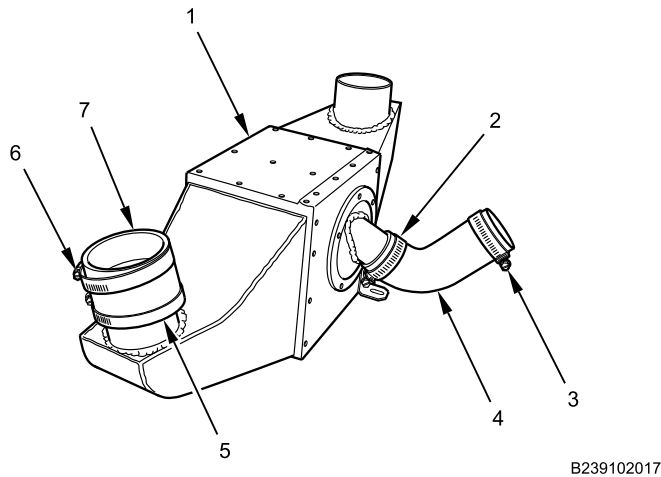
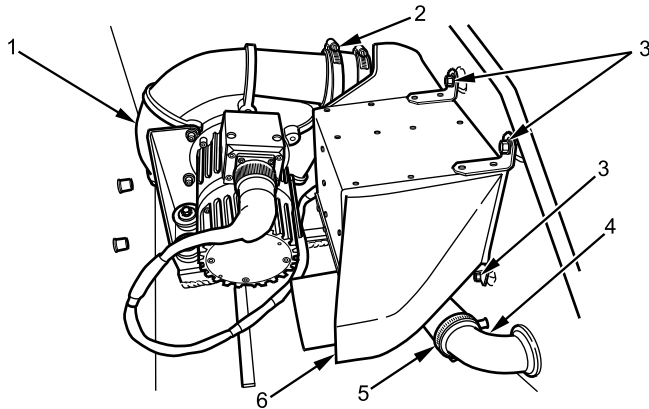

Figure 3. NBC Particle Separator Filter.

2. Position main blower outlet tube (Figure 3, Item 7) on NBC particle separator filter assembly (Figure 3, Item 1) as noted during removal.
3. Install two hose clamps (Figure 3, Item 2 and 5) and tighten securely.
4. Position hose clamp (Figure 3, Item 3) on dust outlet tube (Figure 3, Item 4).
5. Position hose clamp (Figure 3, Item 6) on main blower outlet tube (Figure 3, Item 7).

NUCLEAR, BIOLOGICAL, AND CHEMICAL (NBC) PARTICLE SEPARATOR FILTER REMOVAL AND INSTALLATION - (CONTINUED)

6. Install particle separator filter assembly (Figure 4, Item 6) on main blower motor (Figure 4, Item 1) and dust tube (Figure 4, Item 4) and tighten two hose clamps securely (Figure 4, Item 2 and 5).



B231810808

Figure 4. NBC Particle Separator Filter Mounting.

7. Install three bolts (Figure 4, Item 3), flat washers, and new lockwashers on NBC particle separator filter assembly (Figure 4, Item 6) and tighten securely.

END OF TASK

FOLLOW-ON MAINTENANCE

1. Install NBC filter cover and housing (WP 0763).
2. Install NBC filter (WP 0762).
3. Turn MAIN POWER switch on (TM 9-2355-106-10).
4. Start engine (TM 9-2355-106-10).
5. Close all doors and hatches securely (TM 9-2355-106-10).
6. Turn on Heating Ventilating and Air Conditioning (HVAC)/LSS to verify proper cabin pressure (TM 9-2355-106-10).
7. Turn off HVAC/LSS (TM 9-2355-106-10).
8. Turn engine off (TM 9-2355-106-10).
9. Turn MAIN POWER switch off (TM 9-2355-106-10).
10. Install right side exterior body armor front panel (WP 0633).
11. Remove wheel chocks (TM 9-2355-106-10).

END OF TASK

END OF WORK PACKAGE

FIELD MAINTENANCE

HEATING VENTILATING AND AIR CONDITIONING (HVAC)/LIFE SUPPORT SYSTEM (LSS) MAIN BLOWER MOTOR AND SUPPORT REMOVAL AND INSTALLATION

INITIAL SETUP:

Tools and Special Tools

General Mechanic's Tool Kit (GMTK)
(WP 0795, Item 37)

Materials/Parts

Lockwasher - (4) (WP 0796, Item 173)

References

TM 9-2355-106-10
TM 9-2355-106-23P
WP 0786
WP 0782

Equipment Condition

Parking brake set (TM 9-2355-106-10)

Transmission set in NEUTRAL (N) (TM 9-2355-106-10)

Engine off (TM 9-2355-106-10)

MAIN POWER switch off (TM 9-2355-106-10)

Wheels chocked (TM 9-2355-106-10)

LSS control switch off (TM 9-2355-106-10)

Exterior body armor right front panel removed (WP 0629)

Nuclear, Biological, and Chemical (NBC) filter removed (WP 0762)

NBC filter cover and housing removed (WP 0763)

NBC particle separator filter removed (WP 0764)

HVAC/LSS main blower motor wiring harness removed (WP 0778)

REMOVAL

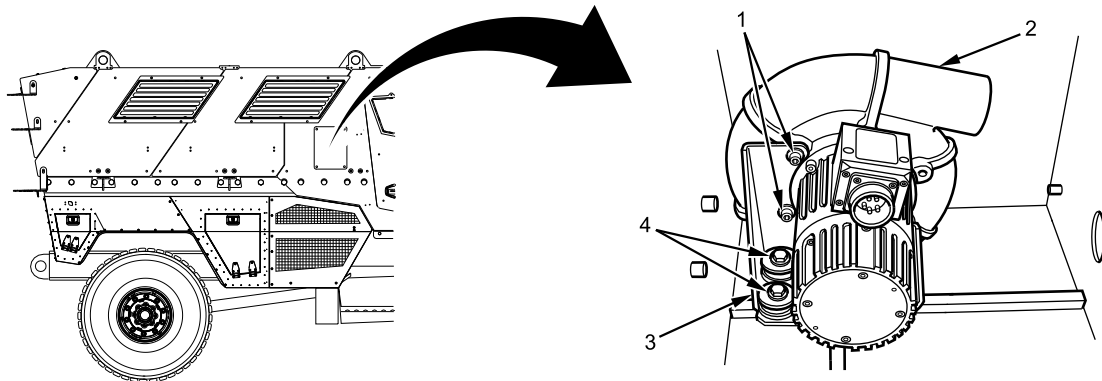

B239110609

Figure 1. HVAC/LSS Main Blower Motor.

1. Loosen four bolts (Figure 1, Item 4) securing main blower support (Figure 1, Item 3).
2. Remove HVAC/LSS main blower motor (Figure 1, Item 2) and support (Figure 1, Item 3).
3. Remove four Allen head bolts (Figure 1, Item 1), flat washers, and lockwashers from support (Figure 1, Item 3). Discard lockwashers. Two bolts shown.
4. Remove support (Figure 1, Item 3) from HVAC/LSS main blower motor (Figure 1, Item 2).

END OF TASK

HEATING VENTILATING AND AIR CONDITIONING (HVAC)/LIFE SUPPORT SYSTEM (LSS) MAIN BLOWER MOTOR AND SUPPORT REMOVAL AND INSTALLATION - (CONTINUED)

INSTALLATION

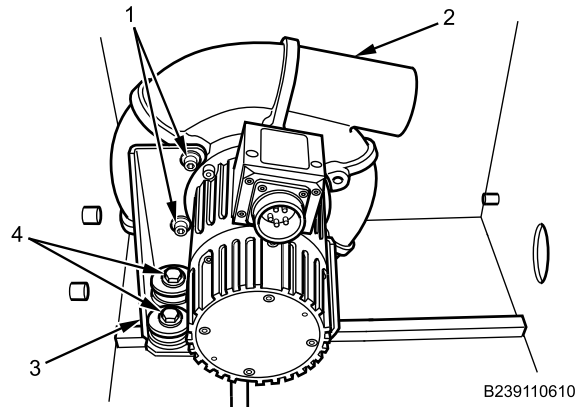

Figure 2. HVAC/LSS Main Blower Motor.

1. Install HVAC/LSS main blower motor (Figure 2, Item 2) on support (Figure 2, Item 3) with four Allen head bolts (Figure 2, Item 1), flat washers, and new lock washers. Tighten bolts securely.
2. Install four bolts (Figure 2, Item 4), eight isolators, and flat washers to main blower support (Figure 2, Item 3).
3. Install HVAC/LSS main blower motor (Figure 2, Item 2) and support (Figure 2, Item 3) into HVAC/LSS housing. Tighten bolts securely.

END OF TASK

FOLLOW-ON MAINTENANCE

1. Install HVAC/LSS main blower motor wiring harness (WP 0778).
2. Install NBC particle separator filter (WP 0764).
3. Install NBC filter cover and housing (WP 0763).
4. Install NBC filter (WP 0762).
5. Turn MAIN POWER switch on (TM 9-2355-106-10).
6. Start engine (TM 9-2355-106-10).
7. Close all doors and hatches securely (TM 9-2355-106-10).
8. Turn on HVAC/LSS to verify proper cabin pressure (TM 9-2355-106-10).
9. Turn off HVAC/LSS (TM 9-2355-106-10).
10. Turn engine off (TM 9-2355-106-10).
11. Turn MAIN POWER switch off (TM 9-2355-106-10).
12. Install right side exterior body armor front panel (WP 0629).
13. Remove wheel chocks (TM 9-2355-106-10).

END OF TASK

END OF WORK PACKAGE

FIELD MAINTENANCE**HEATING VENTILATING AND AIR CONDITIONING/LIFE SUPPORT SYSTEM (HVAC/LSS) UPPER BLOWER
REMOVAL AND INSTALLATION**

INITIAL SETUP:**Tools and Special Tools**

General Mechanic's Tool Kit (GMTK)
(WP 0795, Item 37)
Refrigeration Ordnance Service Tool Kit
(WP 0795, Item 85)

TM 9-2355-106-23P

WP 0786

WP 0782

Materials/Parts

Lockwasher - (25) (WP 0796, Item 168)

Equipment Condition

Parking brake set (TM 9-2355-106-10)

Transmission set in NEUTRAL (N) (TM
9-2355-106-10)

Engine off (TM 9-2355-106-10)

MAIN POWER switch off (TM 9-2355-106-10)

Wheels chocked (TM 9-2355-106-10)

Gunner's platform/stand removed (WP 0668)

HVAC/LSS upper panel removed (WP 0767)

HVAC/LSS diffuser air duct removed (WP 0755)

Personnel Required

Maintainer - (2)

References

TM 9-2355-106-10

HEATING VENTILATING AND AIR CONDITIONING/LIFE SUPPORT SYSTEM (HVAC/LSS) UPPER BLOWER REMOVAL AND INSTALLATION - (CONTINUED)

REMOVAL

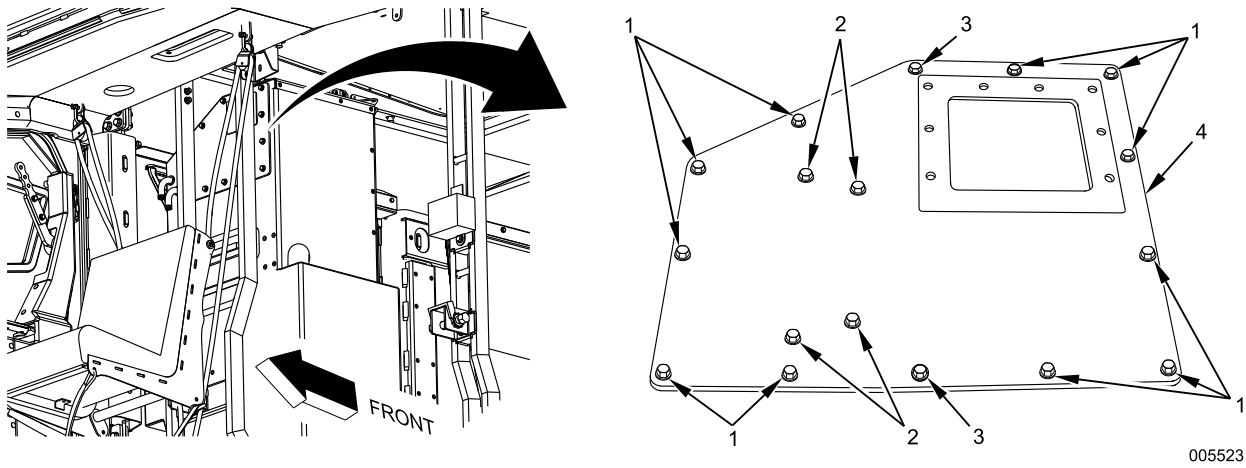

Figure 1. Blower Mounting Panel.

1. Loosen two bolts (Figure 1, Item 3) on blower mounting panel (Figure 1, Item 4).
2. Remove 11 bolts (Figure 1, Item 1), lockwashers, and flat washers from blower mounting panel (Figure 1, Item 4). Discard lockwashers.

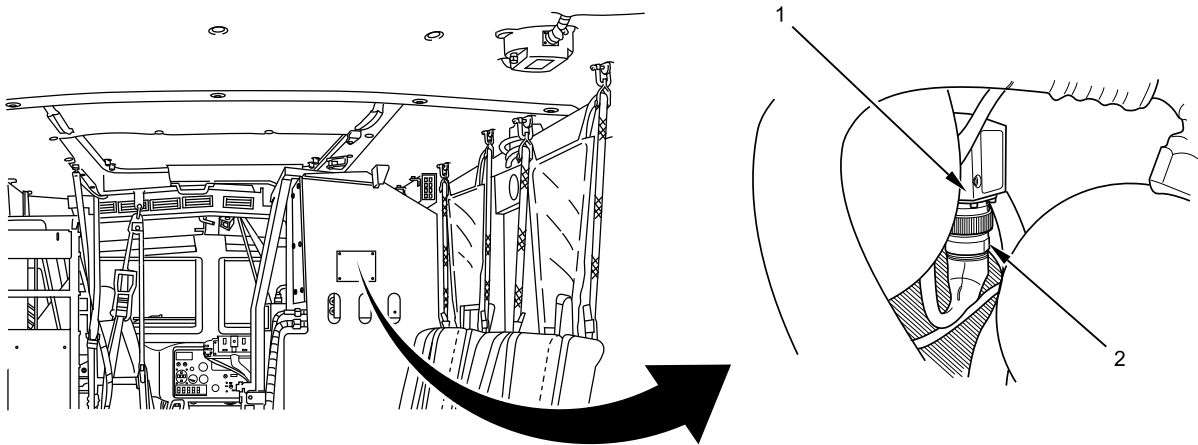

Figure 2. Blower Harness Connector.

CAUTION

Avoid touching heater radiator fins. Failure to comply may result in damage to heater radiator.

3. Disconnect blower motor harness connector (Figure 2, Item 2) from blower motor (Figure 2, Item 1).
4. Loosen four bolts (Figure 2, Item 2) on blower motor mounting panel.
5. With assistant supporting blower assembly, remove six bolts, lockwashers and flat washers (Figure 2, Item 2 and 3) and remove blower mounting panel. Discard lockwashers.
6. Remove blower assembly through blower mounting panel opening.
7. Remove and discard lockwashers from bolts (Figure 2, Item 2) and (Figure 1, Item 1, 2, and 3).

HEATING VENTILATING AND AIR CONDITIONING/LIFE SUPPORT SYSTEM (HVAC/LSS) UPPER BLOWER REMOVAL AND INSTALLATION - (CONTINUED)

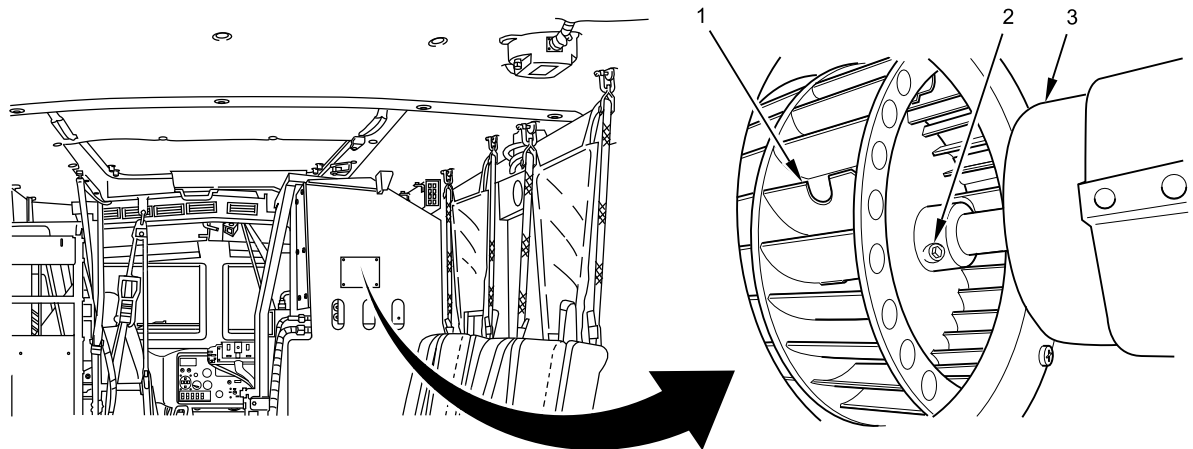

B235203072

Figure 3. Fan Drive Setscrew.

8. Loosen setscrew (Figure 3, Item 2) and separate fan (Figure 3, Item 1) from blower motor (Figure 3, Item 3).

END OF TASK

INSTALLATION

1. Connect fan (Figure 3, Item 1) to blower motor (Figure 3, Item 3) and tighten setscrew (Figure 3, Item 2) securely.

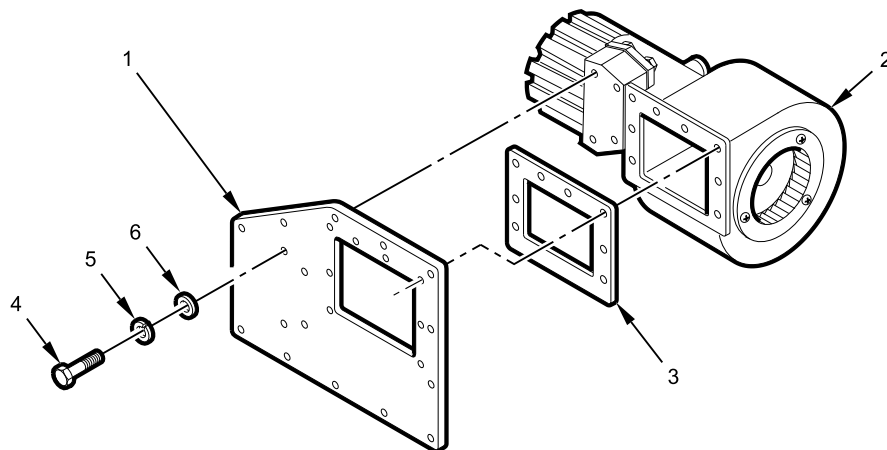

B235203073

Figure 4. Blower Motor and Mounting Panel.

CAUTION

Avoid touching heater radiator fins. Failure to comply may result in damage to heater radiator.

2. Install blower assembly through blower mounting panel opening.

HEATING VENTILATING AND AIR CONDITIONING/LIFE SUPPORT SYSTEM (HVAC/LSS) UPPER BLOWER REMOVAL AND INSTALLATION - (CONTINUED)

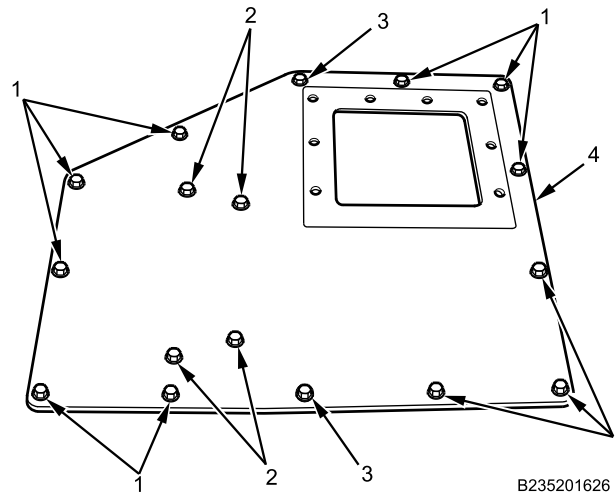

Figure 5. Blower Mounting Panel.

CAUTION

Four bolts (Figure 5, Item 2) are shorter than the rest. Avoid installing long bolts in these locations. Failure to comply may result in damage to components.

3. Loosely install blower mounting panel with two bolts, new lockwashers, and flat washers (Figure 5, Item 3).
4. With assistant supporting blower assembly, loosely install blower motor to mounting plate with four short bolts (Figure 5, Item 2), new lockwashers, and flat washers.

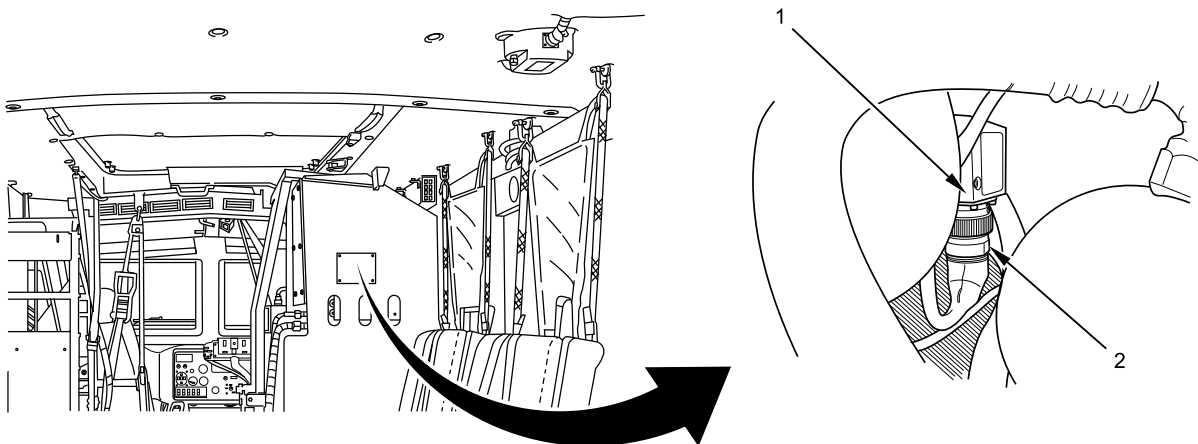

Figure 6. Blower Harness Connector.

5. Connect blower motor harness connector (Figure 6, Item 2) to blower motor (Figure 6, Item 1).
6. Loosely install 11 bolts (Figure 6, Item 1), new lockwashers, and flat washers in blower mounting panel.
7. Tighten bolts (Figure 6, Item 1, 2, and 3) securely.

END OF TASK

**HEATING VENTILATING AND AIR CONDITIONING/LIFE SUPPORT SYSTEM (HVAC/LSS) UPPER BLOWER
REMOVAL AND INSTALLATION - (CONTINUED)****FOLLOW-ON MAINTENANCE**

1. Install diffuser air duct (WP 0755).
2. Install HVAC/LSS upper panel (WP 0767).
3. Install gunner's stand (WP 0668).
4. Turn MAIN POWER switch on (TM 9-2355-106-10).
5. Verify correct blower operation (TM 9-2355-106-10).
6. Turn MAIN POWER switch off (TM 9-2355-106-10).
7. Remove wheel chocks (TM 9-2355-106-10).

END OF TASK**END OF WORK PACKAGE**

FIELD MAINTENANCE

HEATING VENTILATING AND AIR CONDITIONING/LIFE SUPPORT SYSTEM (HVAC/LSS) UPPER PANEL
REMOVAL AND INSTALLATION

INITIAL SETUP:

Tools and Special Tools

General Mechanic's Tool Kit (GMTK)
(WP 0795, Item 37)

WP 0786

WP 0782

Materials/Parts

Lockwasher - (10) (WP 0796, Item 168)

Equipment Condition

Parking brake set (TM 9-2355-106-10)

Transmission set in NEUTRAL (N) (TM
9-2355-106-10)

Engine off (TM 9-2355-106-10)

MAIN POWER switch off (TM 9-2355-106-10)

Wheels chocked (TM 9-2355-106-10)

References

TM 9-2355-106-10

TM 9-2355-106-23P

REMOVAL

1. Remove 10 bolts (Figure 1, Item 1), lockwashers, and washers and remove HVAC cover panel (Figure 1, Item 2). Discard lockwashers.

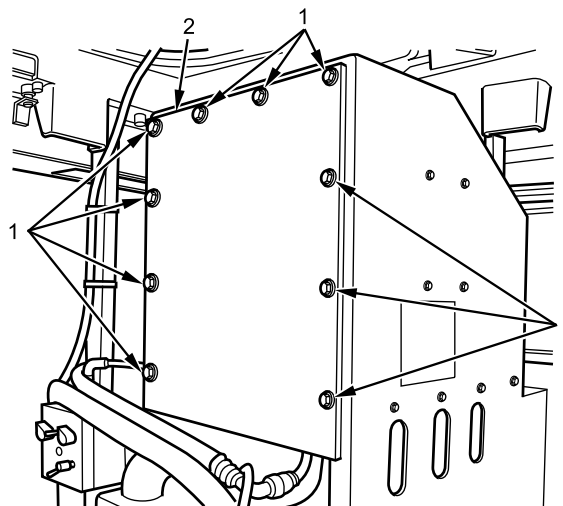

B239101636

Figure 1. HVAC Cover Panel.

END OF TASK

HEATING VENTILATING AND AIR CONDITIONING/LIFE SUPPORT SYSTEM (HVAC/LSS) UPPER PANEL REMOVAL AND INSTALLATION - (CONTINUED)

INSTALLATION

1. Install HVAC cover panel (Figure 2, Item 2) with 10 washers, new lockwashers, and bolts (Figure 2, Item 1).

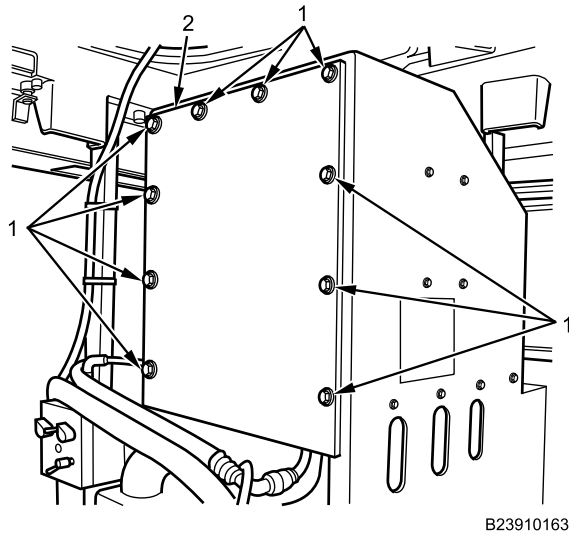

Figure 2. HVAC Cover Panel.

2. Tighten 10 bolts (Figure 2, Item 1) securely.

END OF TASK

FOLLOW-ON MAINTENANCE

1. Remove wheel chocks (TM 9-2355-106-10).

END OF TASK

END OF WORK PACKAGE

FIELD MAINTENANCE

HEATING VENTILATING AND AIR CONDITIONING (HVAC) RECIRCULATED AIR (RA) TEMPERATURE SENSOR REMOVAL AND INSTALLATION

INITIAL SETUP:

Tools and Special Tools

General Mechanic's Tool Kit (GMTK)
(WP 0795, Item 37)

WP 0782

Materials/Parts

Lockwasher - (2) (WP 0796, Item 168)

Equipment Condition

Parking brake set (TM 9-2355-106-10)
Transmission set in NEUTRAL (N) (TM
9-2355-106-10)
Engine off (TM 9-2355-106-10)
MAIN POWER switch off (TM 9-2355-106-10)
Wheels chocked (TM 9-2355-106-10)
HVAC/LSS upper panel removed (WP 0767)

References

TM 9-2355-106-10
TM 9-2355-106-23P
WP 0786

REMOVAL

1. Disconnect harness connector (Figure 1, Item 2) from RA sensor (Figure 1, Item 1).

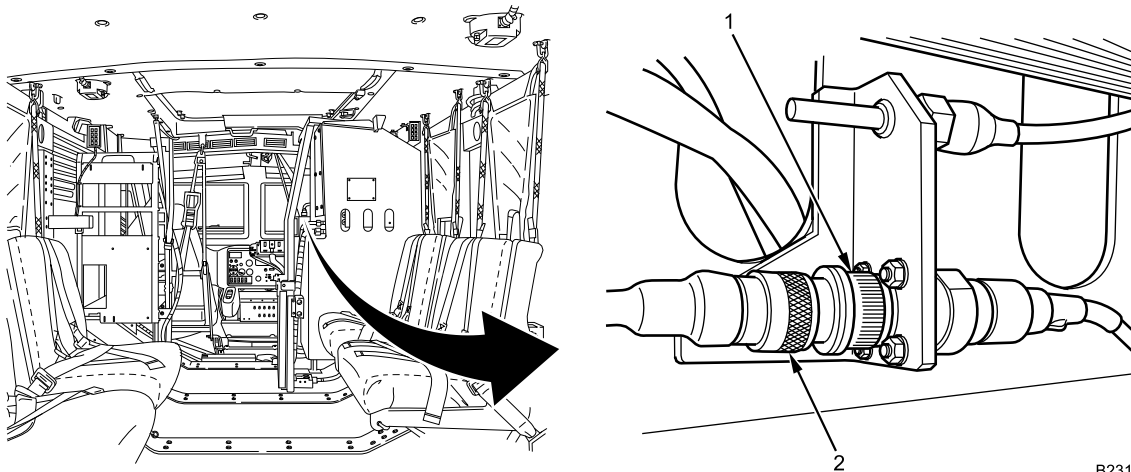

B231810776

Figure 1. RA Sensor Connector.

HEATING VENTILATING AND AIR CONDITIONING (HVAC) RECIRCULATED AIR (RA) TEMPERATURE SENSOR REMOVAL AND INSTALLATION - (CONTINUED)

2. Disconnect harness connector (Figure 2, Item 2) from LSS operator panel (Figure 2, Item 1).

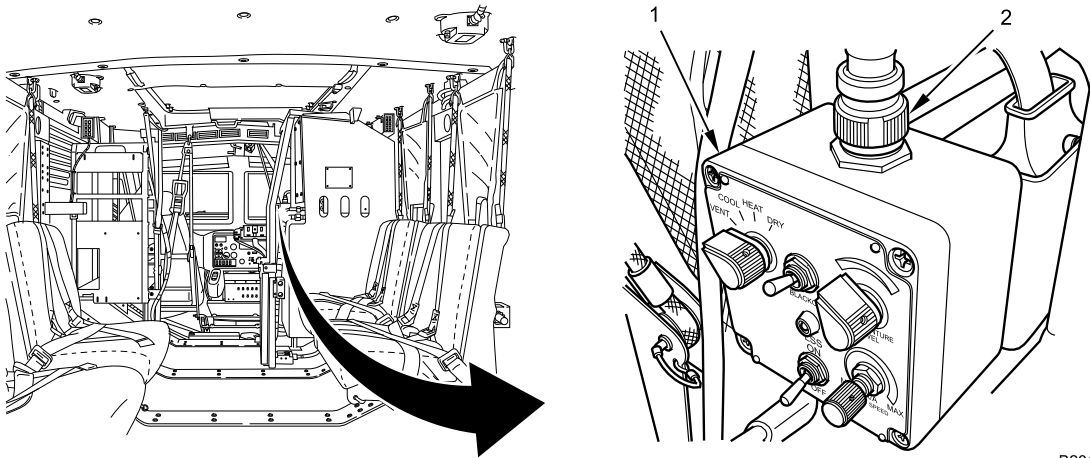

B231810775

Figure 2. LSS Operator Panel Connector.

3. Remove two bolts (Figure 3, Item 1), lockwashers, flat washers, and clamp from RA sensor. Discard lockwashers.

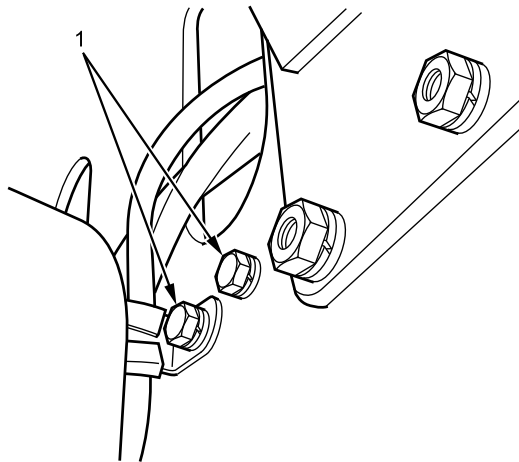

B235202063

Figure 3. RA Sensor Bolts.

END OF TASK

HEATING VENTILATING AND AIR CONDITIONING (HVAC) RECIRCULATED AIR (RA) TEMPERATURE SENSOR REMOVAL AND INSTALLATION - (CONTINUED)**INSTALLATION**

1. Install RA sensor and bracket with two bolts (Figure 4, Item 1), new lockwashers, flat washers, and clamp. Tighten bolts securely.

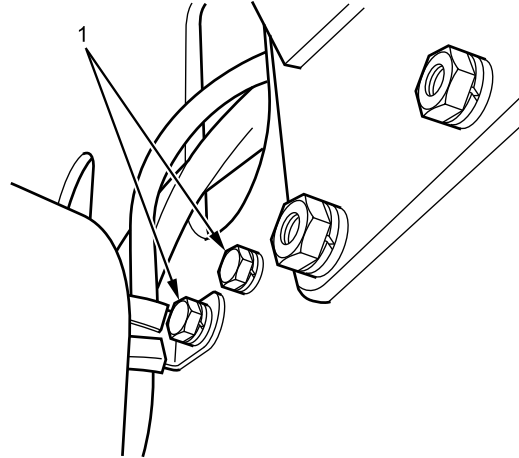

B235202063

Figure 4. RA Sensor Bolts.

2. Connect harness connector (Figure 5, Item 1).

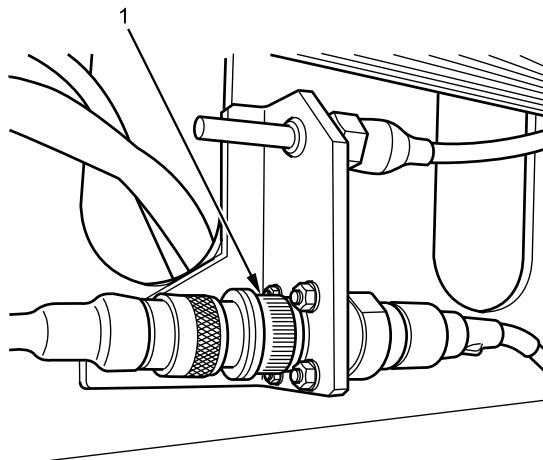

B235202062

Figure 5. RA Sensor Connector.

HEATING VENTILATING AND AIR CONDITIONING (HVAC) RECIRCULATED AIR (RA) TEMPERATURE SENSOR REMOVAL AND INSTALLATION - (CONTINUED)

3. Connect harness connector (Figure 6, Item 2) to LSS operator panel (Figure 6, Item 1).

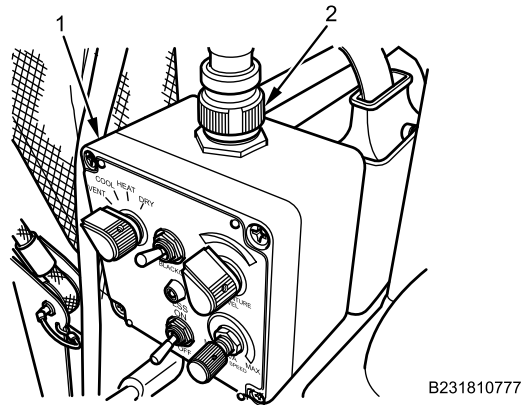

Figure 6. LSS Operator Panel Connector.

END OF TASK**FOLLOW-ON MAINTENANCE**

1. Install HVAC/LSS upper panel (WP 0767).
2. Turn MAIN POWER switch on (TM 9-2355-106-10).
3. Start engine (TM 9-2355-106-10).
4. Turn on HVAC/LSS to check for proper operation (TM 9-2355-106-10).
5. Turn off HVAC/LSS (TM 9-2355-106-10).
6. Turn engine off (TM 9-2355-106-10).
7. Turn MAIN POWER switch off (TM 9-2355-106-10).
8. Remove wheel chocks (TM 9-2355-106-10).

END OF TASK**END OF WORK PACKAGE**

FIELD MAINTENANCE

CLIMATE CONTROL UNIT (CCU) BOX REMOVAL AND INSTALLATION

INITIAL SETUP:

Tools and Special Tools

General Mechanic's Tool Kit (GMTK)
(WP 0795, Item 37)

WP 0786

WP 0782

Materials/Parts

Lockwasher - (4) (WP 0796, Item 168)

Equipment Condition

Parking brake set (TM 9-2355-106-10)

Transmission set in NEUTRAL (N) (TM
9-2355-106-10)

Engine shut off (TM 9-2355-106-10)

MAIN POWER switch off (TM 9-2355-106-10)

Wheels chocked (TM 9-2355-106-10)

References

TM 9-2355-106-10

TM 9-2355-106-23P

REMOVAL

1. Twisting counterclockwise, disconnect Life Support System (LSS) harness connector (Figure 1, Item 4), operating panel harness connector (Figure 1, Item 2), and blower harness connector (Figure 1, Item 3) from top of CCU box (Figure 1, Item 1).

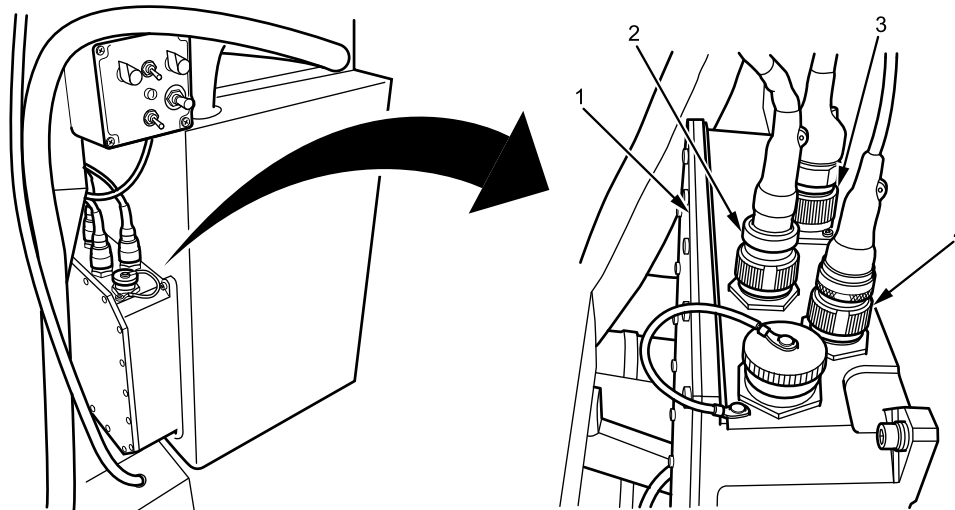

B239103070

Figure 1. CCU Box Upper Connections.

CLIMATE CONTROL UNIT (CCU) BOX REMOVAL AND INSTALLATION - (CONTINUED)

2. Twisting clockwise, disconnect Heating Ventilating and Air Conditioning (HVAC)/LSS control wiring harness connector (Figure 2, Item 2) and HVAC/LSS control power wiring harness connector (Figure 2, Item 3) from bottom of CCU box (Figure 2, Item 1).

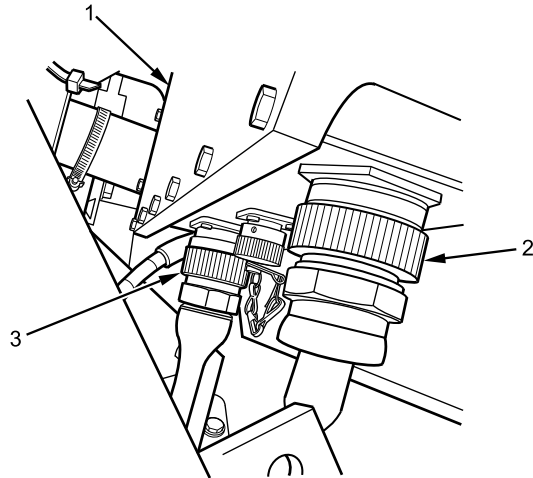

B239102028

Figure 2. CCU Box Lower Connections.

3. Remove bolt (Figure 3, Item 2), flat washer, and ground wire (Figure 3, Item 3) from bottom of CCU box (Figure 3, Item 1).

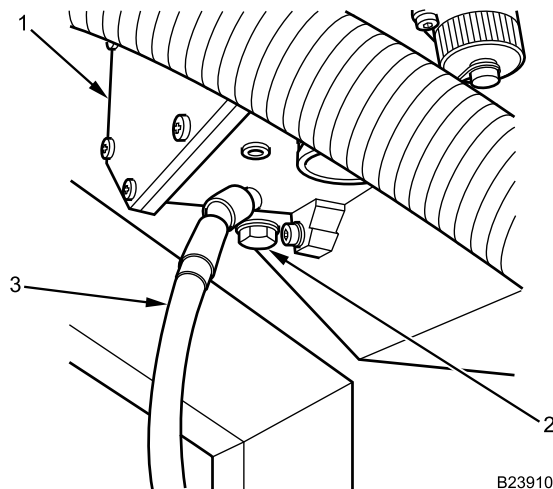

B239102029

Figure 3. CCU Box Ground.

4. Remove four hex head screws (Figure 4, Item 1), lockwashers, and flat washers from CCU box (Figure 4, Item 2). Discard lockwashers.

CLIMATE CONTROL UNIT (CCU) BOX REMOVAL AND INSTALLATION - (CONTINUED)

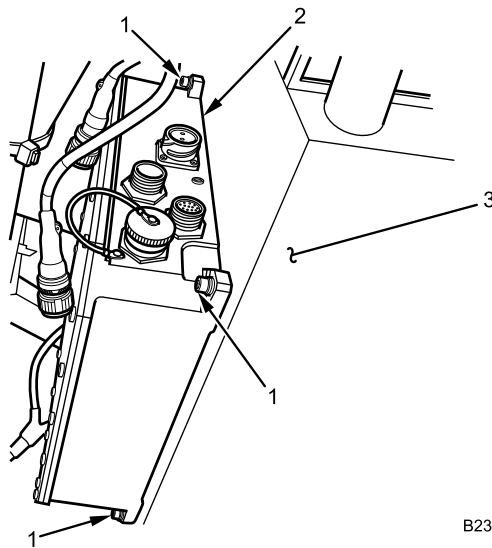

B239101941

Figure 4. CCU Box Mounting.

5. Position CCU box (Figure 4, Item 2) away from HVAC/LSS box (Figure 4, Item 3).
6. Twisting counterclockwise, remove electrical connector (Figure 5, Item 3) from side of CCU box (Figure 5, Item 1).

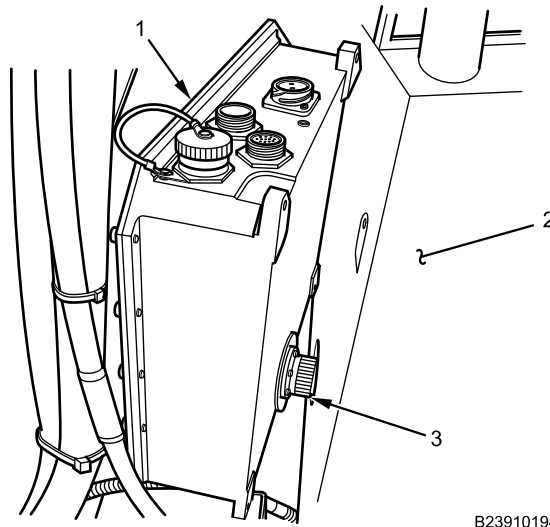

B239101942

Figure 5. CCU Box Side Connector.

7. Remove CCU box (Figure 5, Item 1) from HVAC/LSS box (Figure 5, Item 2).

END OF TASK

CLIMATE CONTROL UNIT (CCU) BOX REMOVAL AND INSTALLATION - (CONTINUED)

INSTALLATION

1. Position CCU box (Figure 6, Item 1) in front of HVAC/LSS box (Figure 6, Item 2).

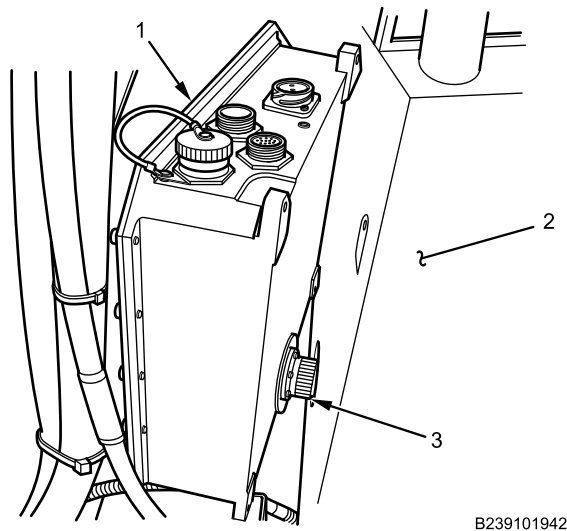

Figure 6. CCU Box Side Connector.

2. Connect electrical connector (Figure 6, Item 3) on side of CCU box (Figure 6, Item 1) by twisting connector clockwise until secure.
3. Install CCU box (Figure 7, Item 2) on HVAC/LSS box (Figure 7, Item 3) with four bolts (Figure 7, Item 1), flat washers, and new lockwashers, and tighten securely.

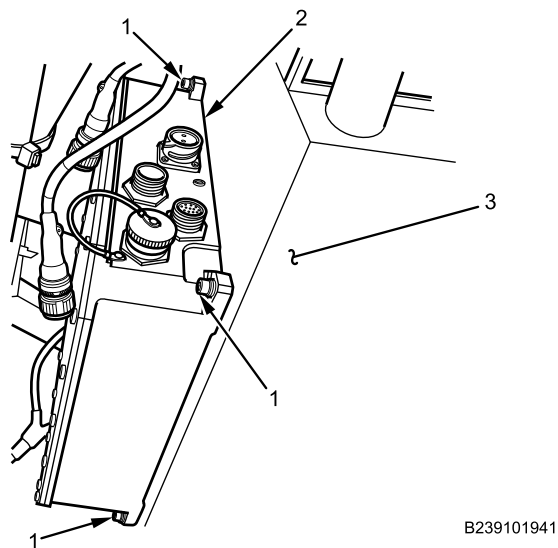
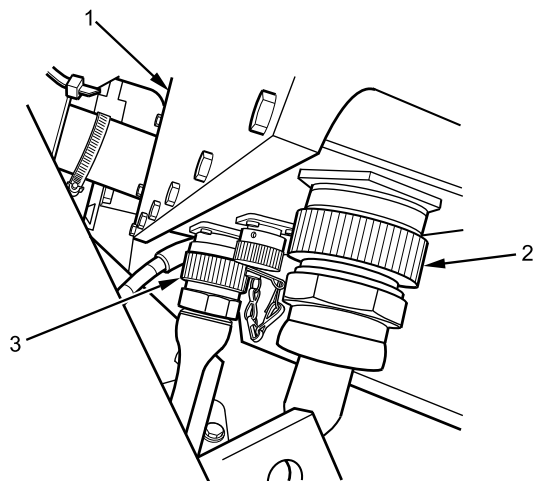

Figure 7. CCU Box Mounting.

4. Connect HVAC/LSS control in wiring harness connector (Figure 8, Item 2) and HVAC/LSS control power wiring harness connector (Figure 8, Item 3) on bottom of CCU box (Figure 8, Item 1) by twisting clockwise until secure.

CLIMATE CONTROL UNIT (CCU) BOX REMOVAL AND INSTALLATION - (CONTINUED)



B239102028

Figure 8. CCU Box Lower Connections.

5. Install ground wire (Figure 9, Item 3) on CCU box (Figure 9, Item 1) with bolt (Figure 9, Item 2) and flat washer, and tighten securely.

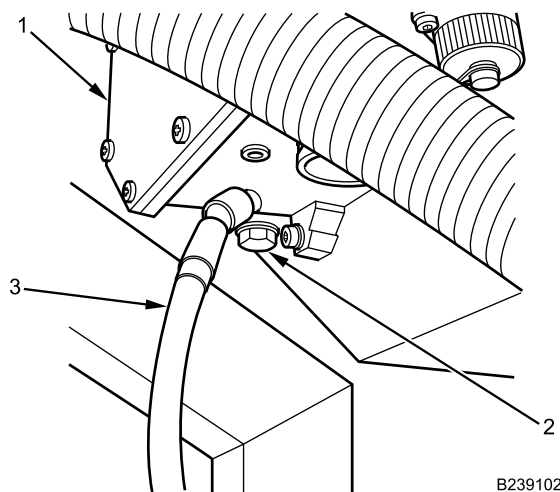

B239102029

Figure 9. CCU Box Ground.

CLIMATE CONTROL UNIT (CCU) BOX REMOVAL AND INSTALLATION - (CONTINUED)

6. Connect LSS harness connector (Figure 10, Item 4), operating panel harness connector (Figure 10, Item 2), and blower harness connector (Figure 10, Item 3) on CCU box (Figure 10, Item 1) by twisting clockwise until secure.

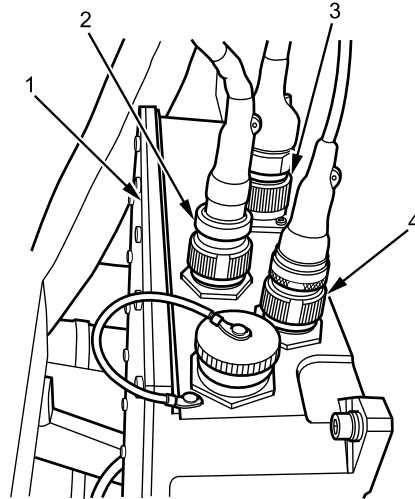

B239101940

Figure 10. CCU Box Upper Connections.

END OF TASK**FOLLOW-ON MAINTENANCE**

1. Turn MAIN POWER switch on (TM 9-2355-106-10).
2. Start engine (TM 9-2355-106-10).
3. Close all doors and hatches securely (TM 9-2355-106-10).
4. Turn on HVAC/LSS to verify proper operation (TM 9-2355-106-10).
5. Turn off HVAC/LSS (TM 9-2355-106-10).
6. Turn engine off (TM 9-2355-106-10).
7. Turn MAIN POWER switch off (TM 9-2355-106-10).
8. Remove wheel chocks (TM 9-2355-106-10).

END OF TASK**END OF WORK PACKAGE**

FIELD MAINTENANCE
**HEATING VENTILATING AND AIR CONDITIONING (HVAC)/LIFE SUPPORT SYSTEM (LSS) OPERATOR
PANEL REMOVAL AND INSTALLATION**

INITIAL SETUP:**Tools and Special Tools**

General Mechanic's Tool Kit (GMTK)
(WP 0795, Item 37)

WP 0786

WP 0782

Materials/Parts

Grease (WP 0794, Item 22)

Equipment Condition

Parking brake set (TM 9-2355-106-10)

Transmission set in NEUTRAL (N) (TM
9-2355-106-10)

Engine off (TM 9-2355-106-10)

MAIN POWER switch off (TM 9-2355-106-10)

Wheels chocked (TM 9-2355-106-10)

References

TM 9-2355-106-10

TM 9-2355-106-23P

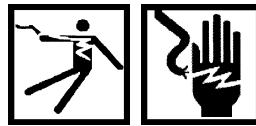
WARNING

Use extreme caution when testing or working on or around electrical circuits. Always assume that electrical circuits are live. Electrical shock can occur upon contact with voltage high enough to cause current flow through muscles or nerves. On Direct Current (DC) systems, generally 1 milliamp of current can be felt, 5 milliamps can cause severe pain, 15 milliamps can cause loss of muscle control, and 70 milliamps can be fatal. Wear protective clothing; ensure skin, clothing, and surrounding areas are dry; do not wear jewelry; and touch only the insulated, nonmetallic parts of electrical components and testing equipment. To prevent electrical arcing, avoid shorting electrical test probes and jumper wires. Electrical arcing can cause bright flashes of light, capable of causing temporary blindness. If electrical injury occurs, immediately shut off power supply and seek medical assistance. Failure to comply may result in serious injury or death to personnel.

NOTE

Note routing of wiring harness for proper installation.

HEATING VENTILATING AND AIR CONDITIONING (HVAC)/LIFE SUPPORT SYSTEM (LSS) OPERATOR PANEL REMOVAL AND INSTALLATION - (CONTINUED)

REMOVAL

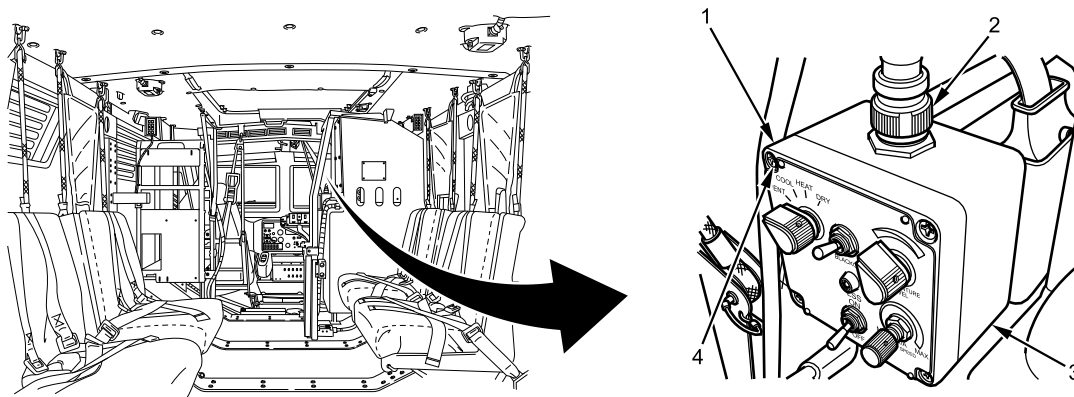

P230613247

Figure 1. LSS Operator Panel.

1. Remove LSS operator panel wiring harness connector from LSS operator panel housing (Figure 1, Item 3) by turning connector collar (Figure 1, Item 2) counterclockwise.
2. Loosen four screws (Figure 1, Item 4) in LSS operator panel (Figure 1, Item 1) until they disengage from the LSS operator panel housing (Figure 1, Item 3).
3. Position LSS operator panel (Figure 1, Item 1) away from LSS operator panel housing (Figure 1, Item 3).

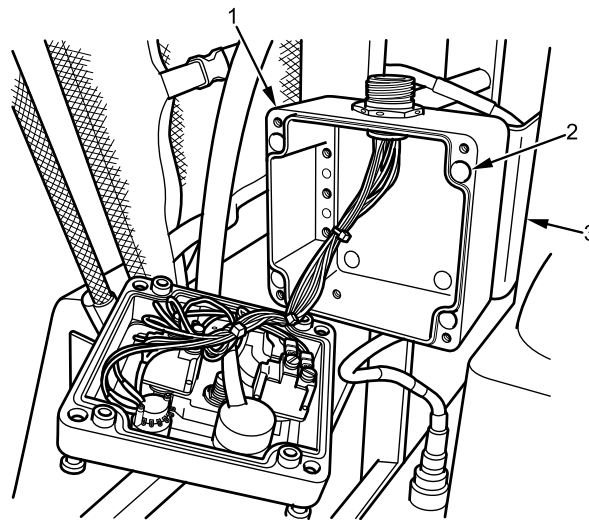

B239102049

Figure 2. LSS Operator Panel Housing.

HEATING VENTILATING AND AIR CONDITIONING (HVAC)/LIFE SUPPORT SYSTEM (LSS) OPERATOR PANEL REMOVAL AND INSTALLATION - (CONTINUED)

4. Remove four bolts (Figure 2, Item 2) from LSS operator panel housing (Figure 2, Item 1). Bolts hidden from view.
5. Remove LSS operator panel housing (Figure 2, Item 1) from bracket (Figure 2, Item 3).

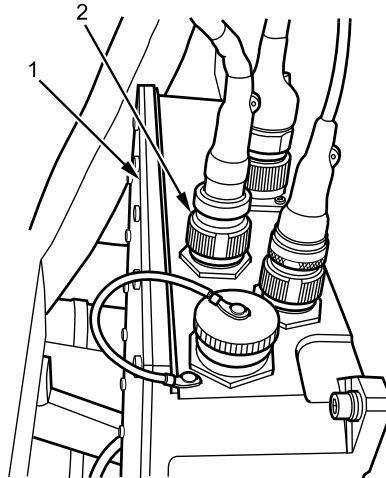

B239102050

Figure 3. LSS Operator Panel Wiring Harness.

6. Remove LSS operator panel wiring harness connector (Figure 3, Item 2) from Climate Control Unit (CCU) box (Figure 3, Item 1) by turning connector collar counterclockwise.
7. Remove LSS operator panel wiring harness from CCU box (Figure 3, Item 1).

END OF TASK

**HEATING VENTILATING AND AIR CONDITIONING (HVAC)/LIFE SUPPORT SYSTEM (LSS) OPERATOR
PANEL REMOVAL AND INSTALLATION - (CONTINUED)****INSTALLATION****WARNING**

Dielectric grease is harmful to skin and eyes. If grease contacts eyes, rinse thoroughly and contact physician if irritation persists. If skin is contacted, wash thoroughly with soap and water. Failure to comply may result in serious injury to personnel.

NOTE

Apply dielectric grease to all electrical contacts before installation.

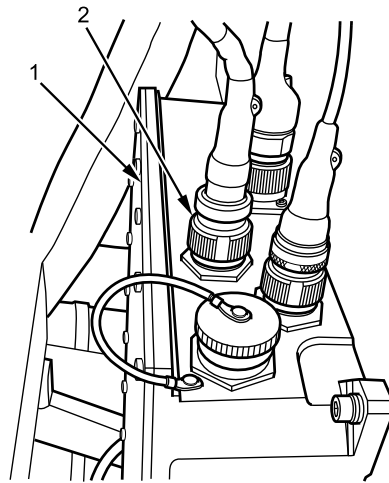

B239102050

Figure 4. LSS Operator Panel Wiring Harness.

1. Install LSS operator panel wiring harness connector (Figure 4, Item 2) on CCU box (Figure 4, Item 1) by turning connector collar clockwise. Tighten collar securely.

HEATING VENTILATING AND AIR CONDITIONING (HVAC)/LIFE SUPPORT SYSTEM (LSS) OPERATOR PANEL REMOVAL AND INSTALLATION - (CONTINUED)

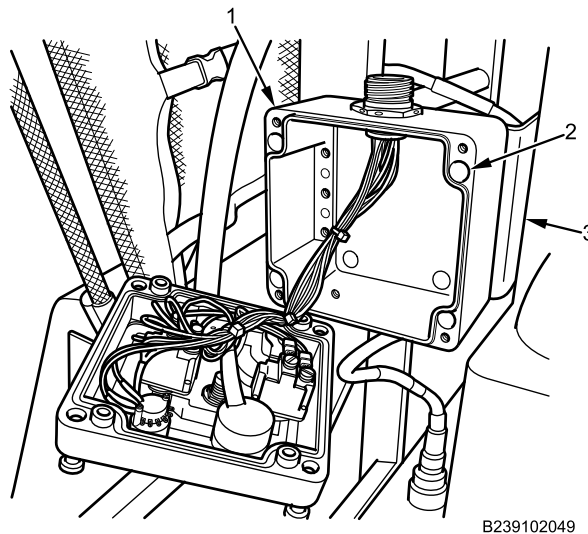

Figure 5. LSS Operator Panel Housing.

2. Install LSS operator panel housing (Figure 5, Item 1) on bracket (Figure 5, Item 3) with four bolts (Figure 5, Item 2) and tighten securely. Bolts hidden from view.

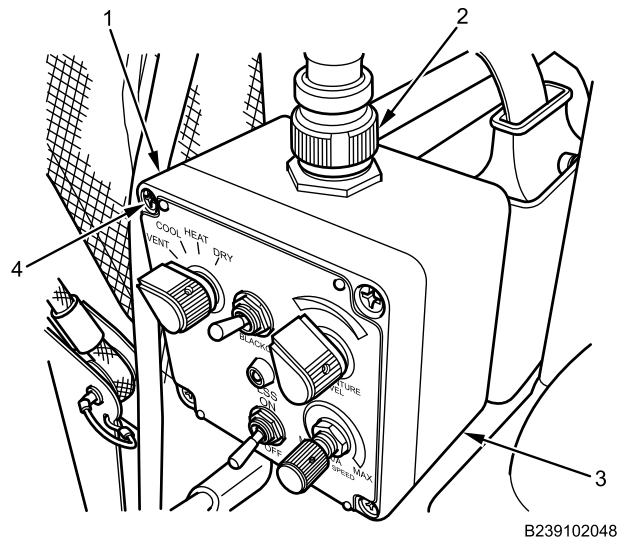

Figure 6. LSS Operator Panel.

3. Install LSS operator panel (Figure 6, Item 1) on LSS operator panel housing (Figure 6, Item 3) with four screws (Figure 6, Item 4). Tighten screws securely.
4. Install LSS operator panel wiring harness connector (Figure 6, Item 2) on LSS operator panel housing (Figure 6, Item 3) by turning connector collar clockwise. Tighten collar securely.

END OF TASK

**HEATING VENTILATING AND AIR CONDITIONING (HVAC)/LIFE SUPPORT SYSTEM (LSS) OPERATOR
PANEL REMOVAL AND INSTALLATION - (CONTINUED)****FOLLOW-ON MAINTENANCE**

1. Turn MAIN POWER switch on (TM 9-2355-106-10).
2. Start engine (TM 9-2355-106-10).
3. Turn on HVAC/LSS to check for proper operation (TM 9-2355-106-10).
4. Turn off HVAC/LSS (TM 9-2355-106-10).
5. Turn engine off (TM 9-2355-106-10).
6. Turn MAIN POWER switch off (TM 9-2355-106-10).
7. Remove wheel chocks (TM 9-2355-106-10).

END OF TASK**END OF WORK PACKAGE**

FIELD MAINTENANCE**HEATING VENTILATING AND AIR CONDITIONING (HVAC) LOW PRESSURE SWITCH REMOVAL AND INSTALLATION**

INITIAL SETUP:**Tools and Special Tools**

General Mechanic's Tool Kit (GMTK)
(WP 0795, Item 37)
Gloves (WP 0795, Item 38)

WP 0786

WP 0782

Materials/Parts

Grease (WP 0794, Item 22)
Goggles, industrial (WP 0794, Item 20)
Face shield, industrial (WP 0794, Item 16)

Equipment Condition

Parking brake set (TM 9-2355-106-10)
Transmission set in NEUTRAL (N) (TM
9-2355-106-10)
Engine off (TM 9-2355-106-10)
MAIN POWER switch off (TM 9-2355-106-10)
Wheels chocked (TM 9-2355-106-10)
Engine hood open and secured (TM 9-2355-106-10)
HVAC system recovered (WP 0707)

References

TM 9-2355-106-10
TM 9-2355-106-23P

HEATING VENTILATING AND AIR CONDITIONING (HVAC) LOW PRESSURE SWITCH REMOVAL AND INSTALLATION - (CONTINUED)

WARNING



Do not install or remove air-conditioning testing or charging equipment while engine is running. Wait 30 seconds after engine shutdown to allow high side and low side pressures to equalize. Failure to comply may result in damage to equipment and environment, and serious injury or death to personnel.

Never open the high side hand valve of the manifold gauge set while HVAC system is operating. If hot, high pressure refrigerant is forced through gauge to refrigerant supply cylinder, which could rupture. Failure to comply may result in damage to equipment and environment, and serious injury or death to personnel.

The temperature of liquid refrigerant is -20°F (-29°C). Wear full face shield, protective rubberized gloves, and protective clothing when working with refrigerant. If refrigerant contacts skin, remove all contaminated clothing. Treat skin as though it were frostbitten or frozen and seek immediate medical attention. If refrigerant contacts eyes, do not rub them. Flush eyes with cold water for at least 15 minutes to gradually increase temperature above freezing point. Seek immediate medical attention. Failure to comply may result in serious injury or death to personnel.

Do not expose refrigerant containers, empty or full, to open flames or temperatures above 125°F (52°C). Do not discard empty containers where they may be subject to heat from a trash burner; refrigerant becomes a poisonous gas in the presence of heat. Do not smoke or allow any type of flame in immediate area while servicing air conditioning system. Never weld, solder, steam clean, or use excessive heat on any part of the air conditioning system while charged/pressurized. Failure to comply may result in damage to equipment and serious injury or death to personnel. Containers may explode. Failure to comply may result in damage to equipment and serious injury or death to personnel.

R-134a refrigerant must not be mixed with air and then pressurized. When mixed with large quantities of air and pressurized, R-134a becomes combustible. Failure to comply may result in damage to equipment and environment, and serious injury or death to personnel.

Refrigerant evaporates very quickly and may displace oxygen surrounding work area, especially in a small or enclosed area. This can cause suffocation or brain damage. If leak occurs, avoid breathing refrigerant vapor and thoroughly ventilate area before continuing service. If personnel breathe refrigerant vapors, obtain immediate medical assistance. Failure to comply may result in serious injury or death to personnel.

Federal and state laws require that refrigerant be recovered and recycled. Refrigerant must be recovered from system with authorized recommended equipment before any work can be performed on unit. Always use approved recycling equipment to prevent accidental discharge. Failure to comply may result in damage to equipment and environment, and serious injury or death to personnel.

Do not check compressor oil level when HVAC system is charged with refrigerant. Never open the high side hand valve of the manifold gauge set while HVAC system is operating. If hot, high pressure refrigerant is forced through gauge to refrigerant supply cylinder, which could rupture. Do not disconnect HVAC lines from compressor. Release of refrigerant may cause damage to equipment or environment and serious injury or death to personnel.

HEATING VENTILATING AND AIR CONDITIONING (HVAC) LOW PRESSURE SWITCH REMOVAL AND INSTALLATION - (CONTINUED)

Do not use parts other than those specified for the system being serviced. Failure to comply may result in damage to equipment and serious injury or death to personnel.

Accidental or intentional introduction of liquid contaminants into the environment is a violation of state, federal, and military regulations. Store, install, and dispose of containers in accordance with standard operating procedures. Refer to Army Petroleum, Oil, and Lubricants (POL) (para. 1-8) for information concerning storage, use, and disposal of liquid contaminants. Failure to comply may result in damage to environment and serious injury or death to personnel.

Use extreme caution when testing or working on or around electrical circuits. Always assume that electrical circuits are live. Electrical shock can occur upon contact with voltage high enough to cause current flow through muscles or nerves. On Direct Current (DC) systems, generally 1 milliamp of current can be felt, 5 milliamps can cause severe pain, 15 milliamps can cause loss of muscle control, and 70 milliamps can be fatal. Wear protective clothing; ensure skin, clothing, and surrounding areas are dry; do not wear jewelry; and touch only the insulated, nonmetallic parts of electrical components and testing equipment. To prevent electrical arcing, avoid shorting electrical test probes and jumper wires. Electrical arcing can cause bright flashes of light, capable of causing temporary blindness. If electrical injury occurs, immediately shut off power supply and seek medical assistance. Failure to comply may result in serious injury or death to personnel.

CAUTION

To prevent damage to test equipment, make sure test equipment is clear of all moving parts in the engine compartment. Failure to comply may result in damage to equipment.

REMOVAL

1. Disconnect electrical connectors (Figure 1, Item 2) from engine harness (Figure 1, Item 1).

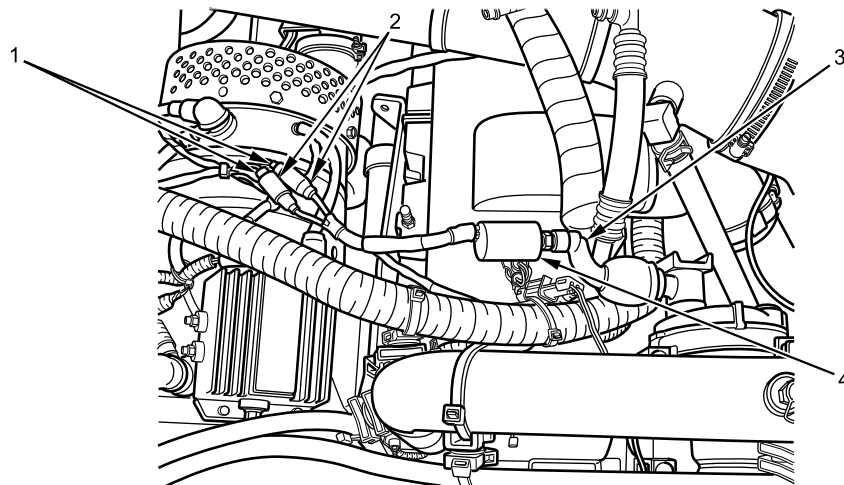

B235203249

Figure 1. HVAC Low Pressure Switch.

2. Remove switch (Figure 1, Item 4) from HVAC line (Figure 1, Item 3).

END OF TASK

HEATING VENTILATING AND AIR CONDITIONING (HVAC) LOW PRESSURE SWITCH REMOVAL AND INSTALLATION - (CONTINUED)**INSTALLATION****WARNING**

Dielectric grease is harmful to skin and eyes. If grease contacts eyes, rinse thoroughly and contact physician if irritation persists. If skin is contacted, wash thoroughly with soap and water. Failure to comply may result in serious injury to personnel.

NOTE

Apply dielectric grease to all electrical connections.

1. Ensure HVAC line (Figure 2, Item 3) and switch (Figure 2, Item 4) are clean and dry.

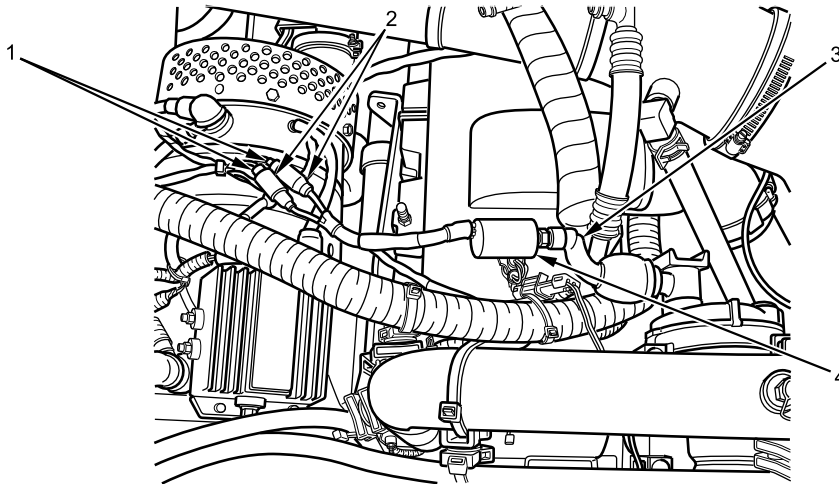

B235203249

Figure 2. HVAC Low Pressure Switch.

2. Install switch (Figure 2, Item 4) on HVAC line (Figure 2, Item 3). Tighten securely.
3. Connect electrical connectors (Figure 2, Item 2) to engine harness (Figure 2, Item 1).

END OF TASK

HEATING VENTILATING AND AIR CONDITIONING (HVAC) LOW PRESSURE SWITCH REMOVAL AND INSTALLATION - (CONTINUED)**FOLLOW-ON MAINTENANCE**

1. Recharge HVAC system (WP 0707).
2. Turn MAIN POWER switch on (TM 9-2355-106-10).
3. Start engine (TM 9-2355-106-10).
4. Verify HVAC system operation (TM 9-2355-106-10).
5. Turn engine off (TM 9-2355-106-10).
6. Turn MAIN POWER switch off (TM 9-2355-106-10).
7. Remove wheel chocks (TM 9-2355-106-10).

END OF TASK**END OF WORK PACKAGE**

FIELD MAINTENANCE
**HEATING VENTILATING AND AIR CONDITIONING (HVAC) LEFT CONDENSER CONTROL WIRING
HARNESS REMOVAL AND INSTALLATION**

INITIAL SETUP:**Tools and Special Tools**

General Mechanic's Tool Kit (GMTK)
(WP 0795, Item 37)

WP 0782

Materials/Parts

Grease (WP 0794, Item 22)
Wire (WP 0794, Item 57)
Cable lock strap - (4) (WP 0796, Item 134)

Equipment Condition

Parking brake set (TM 9-2355-106-10)
Transmission set in NEUTRAL (N) (TM
9-2355-106-10)
Engine off (TM 9-2355-106-10)
MAIN POWER switch off (TM 9-2355-106-10)
Wheels chocked (TM 9-2355-106-10)
Engine hood open and secured (TM 9-2355-106-10)
Air Conditioning A/C condenser panel removed
(WP 0672)

References

TM 9-2355-106-10
TM 9-2355-106-23P
WP 0786

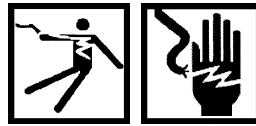
WARNING

Use extreme caution when testing or working on or around electrical circuits. Always assume that electrical circuits are live. Electrical shock can occur upon contact with voltage high enough to cause current flow through muscles or nerves. On Direct Current (DC) systems, generally 1 milliamp of current can be felt, 5 milliamps can cause severe pain, 15 milliamps can cause loss of muscle control, and 70 milliamps can be fatal. Wear protective clothing; ensure skin, clothing, and surrounding areas are dry; do not wear jewelry; and touch only the insulated, nonmetallic parts of electrical components and testing equipment. To prevent electrical arcing, avoid shorting electrical test probes and jumper wires. Electrical arcing can cause bright flashes of light, capable of causing temporary blindness. If electrical injury occurs, immediately shut off power supply and seek medical assistance. Failure to comply may result in serious injury or death to personnel.

NOTE

Remove cable lock straps as necessary to perform procedure. Note position and size of cable lock straps to aid installation.

HEATING VENTILATING AND AIR CONDITIONING (HVAC) LEFT CONDENSER CONTROL WIRING HARNESS REMOVAL AND INSTALLATION - (CONTINUED)

REMOVAL

1. Disconnect harness connector (Figure 1, Item 1) from condenser (Figure 1, Item 2).

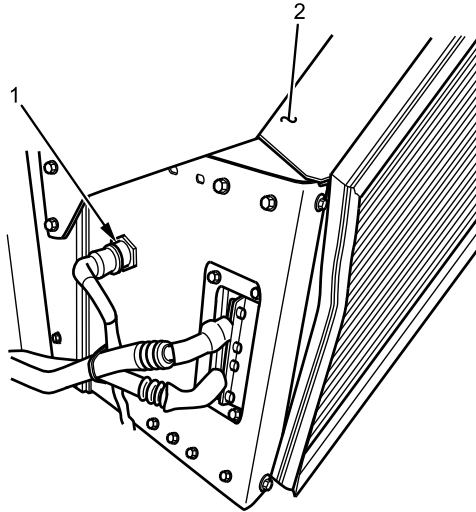

B235202484

Figure 1. Left Condenser.

2. Disconnect harness connections (Figure 2, Item 2) from left side condenser wiring harness (Figure 2, Item 1) at engine compartment.

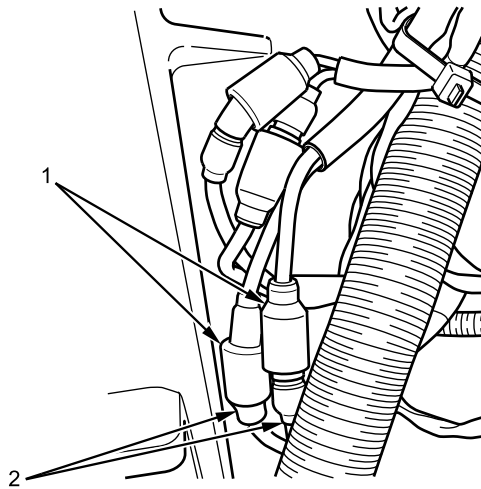

B235202483

Figure 2. Left Condenser Harness Connectors.

3. Connect mechanic's wire securely to harness in engine area.
4. Pull harness and mechanic's wire to condenser.
5. Disconnect mechanic's wire from harness.

END OF TASK

HEATING VENTILATING AND AIR CONDITIONING (HVAC) LEFT CONDENSER CONTROL WIRING HARNESS REMOVAL AND INSTALLATION - (CONTINUED)

INSTALLATION

WARNING



Dielectric grease is harmful to skin and eyes. If grease contacts eyes, rinse thoroughly and contact physician if irritation persists. If skin is contacted, wash thoroughly with soap and water. Failure to comply may result in serious injury to personnel.

NOTE

Apply dielectric grease to all electrical connections.

1. Connect mechanic's wire securely to end of engine harness at condenser.
2. Pull mechanic's wire and harness to engine compartment. Disconnect mechanic's wire from harness.
3. Connect harness connector (Figure 3, Item 1) to condenser (Figure 3, Item 2).

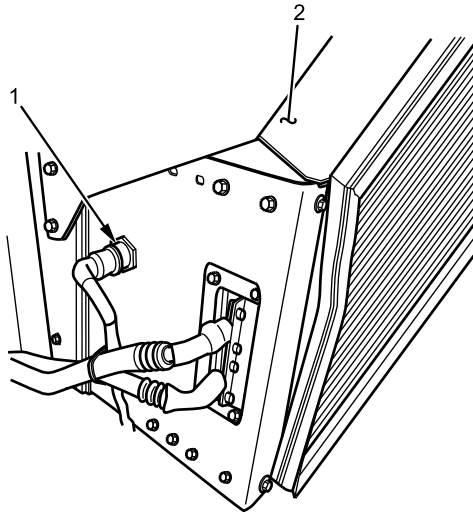

B235202484

Figure 3. Left Condenser.

4. Connect harness connectors (Figure 4, Item 2) to left side condenser wiring harness connector (Figure 4, Item 1) at engine compartment.

**HEATING VENTILATING AND AIR CONDITIONING (HVAC) LEFT CONDENSER CONTROL WIRING HARNESS
REMOVAL AND INSTALLATION - (CONTINUED)**

Figure 4. Left Condenser Harness Connectors.

5. Install new cable lock straps and tighten securely.

END OF TASK**FOLLOW-ON MAINTENANCE**

1. Turn MAIN POWER switch on (TM 9-2355-106-10).
2. Start engine (TM 9-2355-106-10).
3. Turn on HVAC/LSS to check for proper operation (TM 9-2355-106-10).
4. Turn off HVAC/LSS (TM 9-2355-106-10).
5. Turn engine off (TM 9-2355-106-10).
6. Turn MAIN POWER switch off (TM 9-2355-106-10).
7. Install Air Conditioning A/C condenser panel (WP 0672).
8. Close engine hood (TM 9-2355-106-10).
9. Remove wheel chocks (TM 9-2355-106-10).

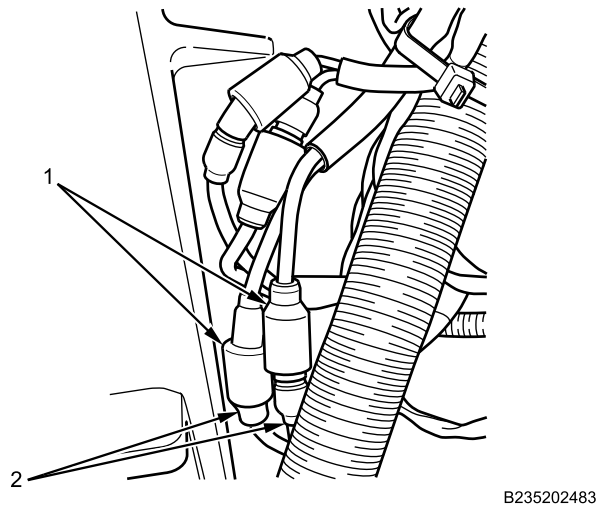
END OF TASK**END OF WORK PACKAGE**

FIELD MAINTENANCE
**HEATING VENTILATING AND AIR CONDITIONING (HVAC) RIGHT CONDENSER CONTROL WIRING
HARNESS REMOVAL AND INSTALLATION**

INITIAL SETUP:**Tools and Special Tools**

General Mechanic's Tool Kit (GMTK)
(WP 0795, Item 37)

WP 0782

Materials/Parts

Grease (WP 0794, Item 22)
Wire (WP 0794, Item 57)
Cable lock strap - (6) (WP 0796, Item 134)

Equipment Condition

Parking brake set (TM 9-2355-106-10)
Transmission set in NEUTRAL (N) (TM
9-2355-106-10)
Engine off (TM 9-2355-106-10)
MAIN POWER switch off (TM 9-2355-106-10)
Wheels chocked (TM 9-2355-106-10)
Engine hood open and secured (TM 9-2355-106-10)
Air Conditioning A/C condenser panel removed
(WP 0672)

References

TM 9-2355-106-10
TM 9-2355-106-23P
WP 0786

WARNING

Use extreme caution when testing or working on or around electrical circuits. Always assume that electrical circuits are live. Electrical shock can occur upon contact with voltage high enough to cause current flow through muscles or nerves. On Direct Current (DC) systems, generally 1 milliamp of current can be felt, 5 milliamps can cause severe pain, 15 milliamps can cause loss of muscle control, and 70 milliamps can be fatal. Wear protective clothing; ensure skin, clothing, and surrounding areas are dry; do not wear jewelry; and touch only the insulated, nonmetallic parts of electrical components and testing equipment. To prevent electrical arcing, avoid shorting electrical test probes and jumper wires. Electrical arcing can cause bright flashes of light, capable of causing temporary blindness. If electrical injury occurs, immediately shut off power supply and seek medical assistance. Failure to comply may result in serious injury or death to personnel.

NOTE

Remove cable lock straps as necessary to perform procedure. Note position and size of cable lock straps to aid installation.

HEATING VENTILATING AND AIR CONDITIONING (HVAC) RIGHT CONDENSER CONTROL WIRING HARNESS REMOVAL AND INSTALLATION - (CONTINUED)

REMOVAL

1. Disconnect harness connector (Figure 1, Item 1) from condenser (Figure 1, Item 2).

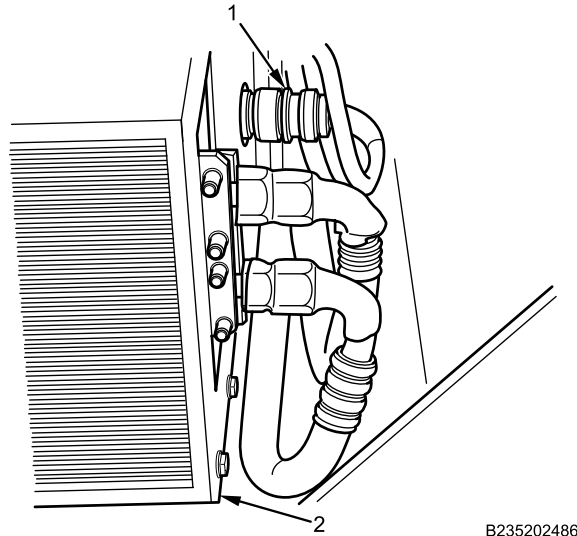

B235202486

Figure 1. Right Condenser.

2. Connect mechanic's wire to harness connector (Figure 1, Item 1).
3. Disconnect harness connections (Figure 2, Item 2) at engine compartment from right side condenser wiring harness connectors (Figure 2, Item 1).

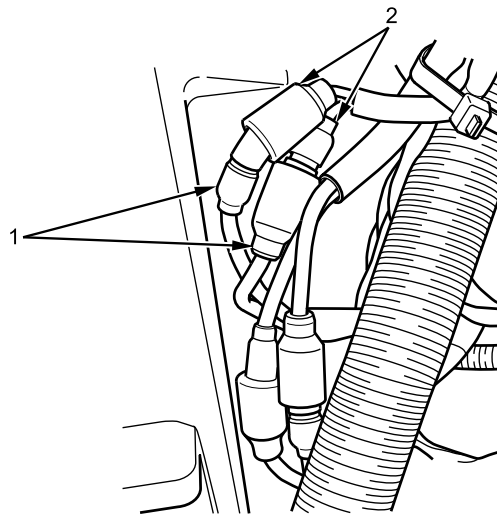

B235202485

Figure 2. Right Condenser Harness Connectors.

4. Pull harness and mechanic's wire to engine compartment.
5. Disconnect mechanic's wire from harness.

END OF TASK

HEATING VENTILATING AND AIR CONDITIONING (HVAC) RIGHT CONDENSER CONTROL WIRING HARNESS REMOVAL AND INSTALLATION - (CONTINUED)**INSTALLATION****WARNING**

Dielectric grease is harmful to skin and eyes. If grease contacts eyes, rinse thoroughly and contact physician if irritation persists. If skin is contacted, wash thoroughly with soap and water. Failure to comply may result in serious injury to personnel.

NOTE

Apply dielectric grease to all electrical contacts before installation.

1. Connect mechanic's wire securely to condenser end of harness at engine compartment.
2. Pull mechanic's wire and harness to condenser. Disconnect mechanic's wire from harness.
3. Connect harness connector (Figure 3, Item 1) to condenser (Figure 3, Item 2).

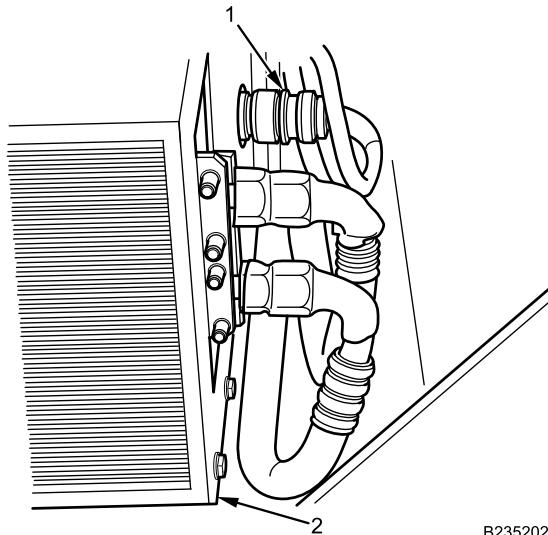

B235202486

Figure 3. Right Condenser.

HEATING VENTILATING AND AIR CONDITIONING (HVAC) RIGHT CONDENSER CONTROL WIRING HARNESS REMOVAL AND INSTALLATION - (CONTINUED)

4. Connect harness connectors (Figure 4, Item 2) to right side condenser wiring harness connectors (Figure 4, Item 1) at engine compartment.

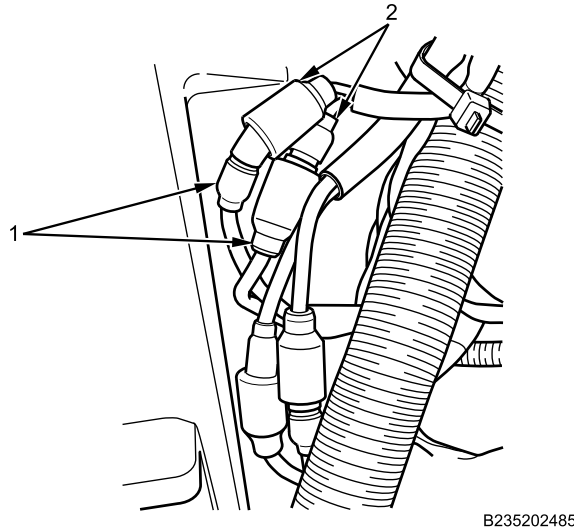

Figure 4. Right Condenser Harness Connectors.

5. Install new cable lock straps and tighten securely.

END OF TASK**FOLLOW-ON MAINTENANCE**

1. Turn MAIN POWER switch on (TM 9-2355-106-10).
2. Start engine (TM 9-2355-106-10).
3. Turn on HVAC/LSS to check for proper operation (TM 9-2355-106-10).
4. Turn off HVAC/LSS (TM 9-2355-106-10).
5. Turn engine off (TM 9-2355-106-10).
6. Turn MAIN POWER switch off (TM 9-2355-106-10).
7. Install Air Conditioning A/C condenser panel (WP 0672).
8. Close engine hood (TM 9-2355-106-10).
9. Remove wheel chocks (TM 9-2355-106-10).

END OF TASK**END OF WORK PACKAGE**

FIELD MAINTENANCE
**HEATING VENTILATING AND AIR CONDITIONING (HVAC)/LIFE SUPPORT SYSTEM (LSS) ENGINE WIRING
HARNESS REMOVAL AND INSTALLATION**

INITIAL SETUP:**Tools and Special Tools**

General Mechanic's Tool Kit (GMTK)
(WP 0795, Item 37)

WP 0786

WP 0782

Materials/Parts

Grease (WP 0794, Item 22)
O-ring (WP 0796, Item 34)
Cable lock strap - (4) (WP 0796, Item 134)

Equipment Condition

Parking brake set (TM 9-2355-106-10)
Transmission set in NEUTRAL (N) (TM
9-2355-106-10)
Engine off (TM 9-2355-106-10)
MAIN POWER switch off (TM 9-2355-106-10)
Wheels chocked (TM 9-2355-106-10)
Engine hood open and secured (TM 9-2355-106-10)
Right door open and secured (WP 0608)

References

TM 9-2355-106-10
TM 9-2355-106-23P

WARNING

Engine hood is extremely heavy and requires two-person lift. Ensure that there is adequate space in front of the vehicle to open hood completely without pinning or pinching personnel between hood and any other structure. Use extreme care when working under hood and make sure it is properly supported. Failure to comply may result in serious injury or death to personnel.

Use extreme caution when testing or working on or around electrical circuits. Always assume that electrical circuits are live. Electrical shock can occur upon contact with voltage high enough to cause current flow through muscles or nerves. On Direct Current (DC) systems, generally 1 milliamp of current can be felt, 5 milliamps can cause severe pain, 15 milliamps can cause loss of muscle control, and 70 milliamps can be fatal. Wear protective clothing; ensure skin, clothing, and surrounding areas are dry; do not wear jewelry; and touch only the insulated, nonmetallic parts of electrical components and testing equipment. To prevent electrical arcing, avoid shorting electrical test probes and jumper wires. Electrical arcing can cause bright flashes of light, capable of causing temporary blindness. If electrical injury occurs, immediately shut off power supply and seek medical assistance. Failure to comply may result in serious injury or death to personnel.

NOTE

Remove cable lock straps as necessary to perform procedure. Note position and size of cable lock straps to aid installation.

HEATING VENTILATING AND AIR CONDITIONING (HVAC)/LIFE SUPPORT SYSTEM (LSS) ENGINE WIRING HARNESS REMOVAL AND INSTALLATION - (CONTINUED)

REMOVAL

1. Disconnect interior harness connector (Figure 1, Item 2) from HVAC/LSS engine wiring harness (Figure 1, Item 3) at penetration dust plate (Figure 1, Item 1).

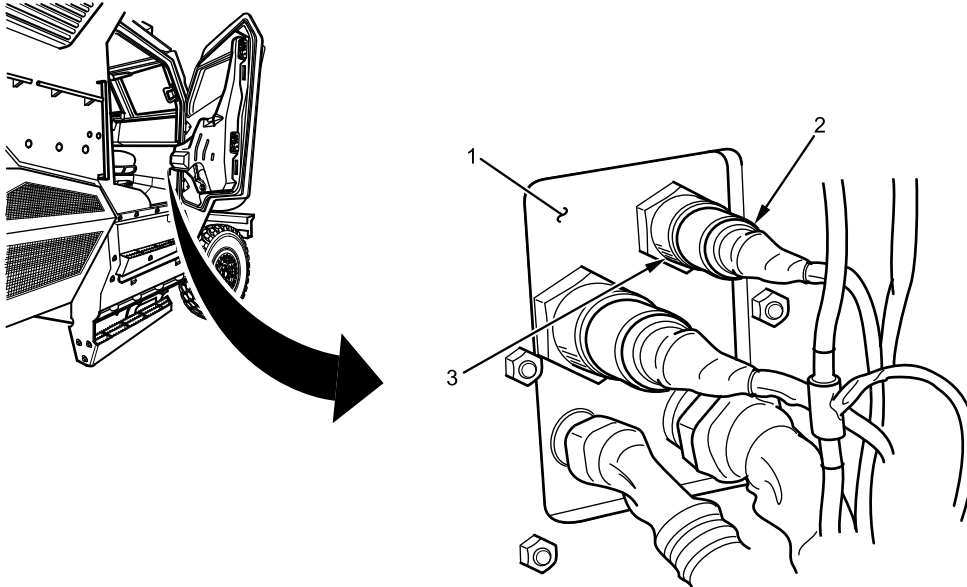

B239110029

Figure 1. Interior Penetration Plate.

2. Remove nut (Figure 2, Item 1) from HVAC/LSS engine wiring harness (Figure 2, Item 2) at penetration dust plate (Figure 2, Item 3).

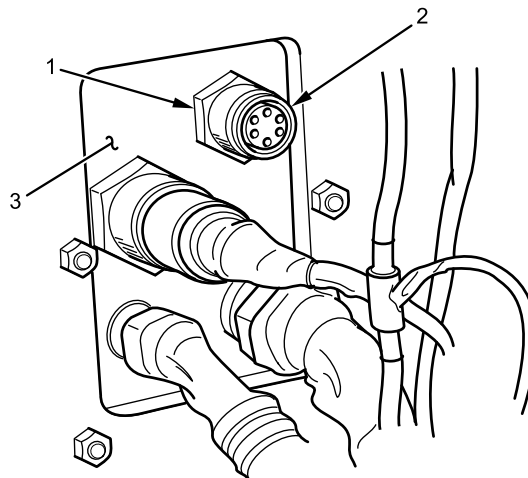

B239102898

Figure 2. Interior HVAC/LSS Wiring Harness.

HEATING VENTILATING AND AIR CONDITIONING (HVAC)/LIFE SUPPORT SYSTEM (LSS) ENGINE WIRING HARNESS REMOVAL AND INSTALLATION - (CONTINUED)

3. Remove HVAC/LSS wiring harness (Figure 3, Item 1) from penetration dust plate (Figure 3, Item 2).

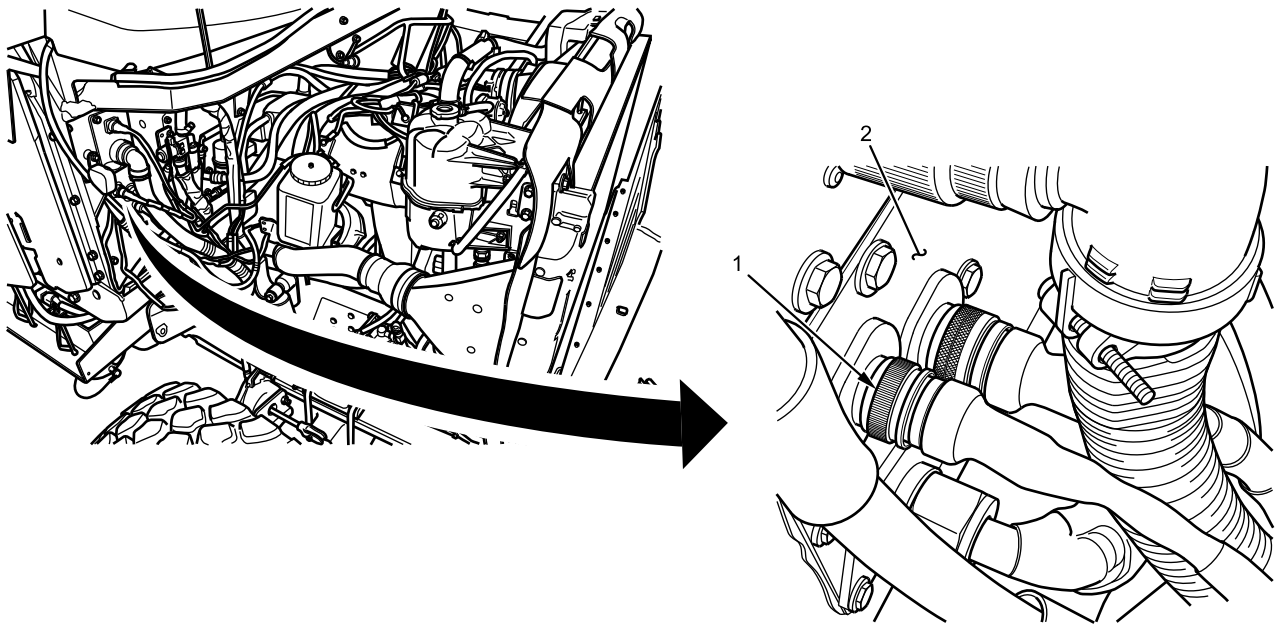

B239110030

Figure 3. Penetration Plate.

4. Remove O-ring (Figure 4, Item 1) from HVAC/LSS engine wiring harness (Figure 4, Item 2). Discard O-ring.

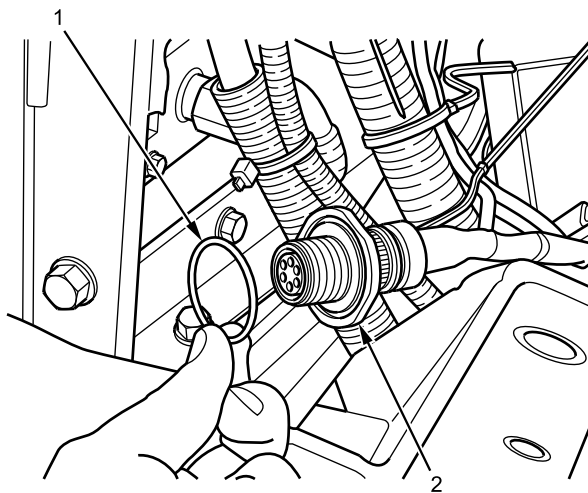

B239102899

Figure 4. HVAC/LSS Engine Harness O-Ring.

HEATING VENTILATING AND AIR CONDITIONING (HVAC)/LIFE SUPPORT SYSTEM (LSS) ENGINE WIRING HARNESS REMOVAL AND INSTALLATION - (CONTINUED)

5. Disconnect harness connectors (Figure 5, Item 1) at 3-way valve.

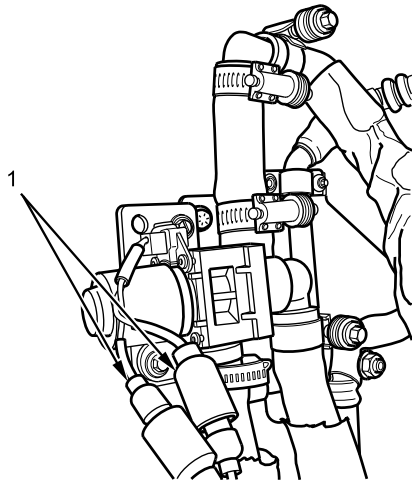

B235202508

Figure 5. 3-Way Valve.

6. Disconnect high idle request circuit harness connector (Figure 6, Item 1).

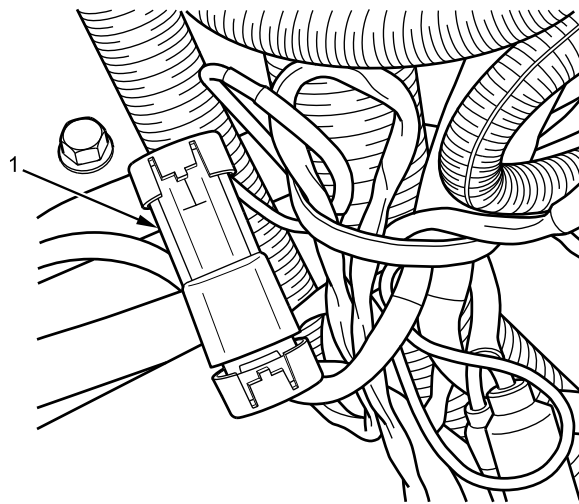

B235202510

Figure 6. High Idle Request Circuit Connector.

HEATING VENTILATING AND AIR CONDITIONING (HVAC)/LIFE SUPPORT SYSTEM (LSS) ENGINE WIRING HARNESS REMOVAL AND INSTALLATION - (CONTINUED)

7. Disconnect harness connectors (Figure 7, Item 1) at low pressure switch.

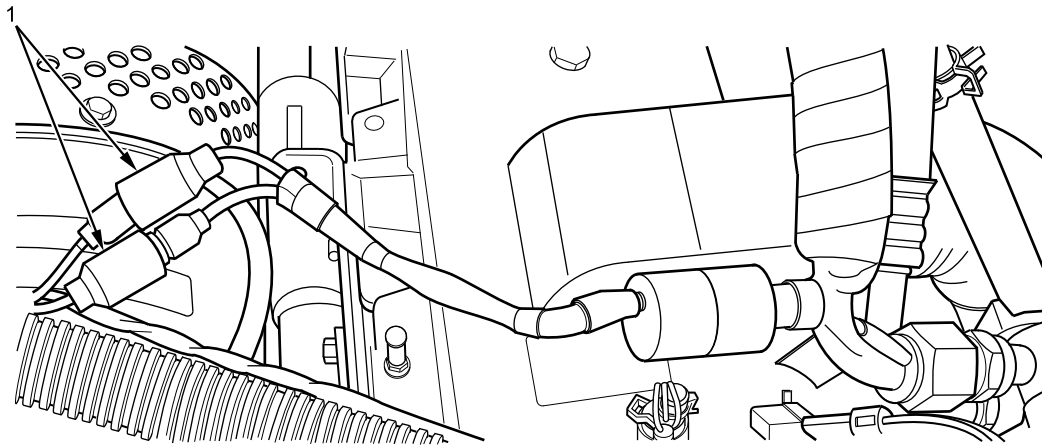

B235202509

Figure 7. Low Pressure Switch Connector.

8. Remove LSS engine wiring harness from vehicle.

END OF TASK

HEATING VENTILATING AND AIR CONDITIONING (HVAC)/LIFE SUPPORT SYSTEM (LSS) ENGINE WIRING HARNESS REMOVAL AND INSTALLATION - (CONTINUED)**INSTALLATION****WARNING**

Dielectric grease is harmful to skin and eyes. If grease contacts eyes, rinse thoroughly and contact physician if irritation persists. If skin is contacted, wash thoroughly with soap and water. Failure to comply may result in serious injury to personnel.

NOTE

Apply dielectric grease to all electrical connections.

1. Install LSS engine wiring harness on vehicle.

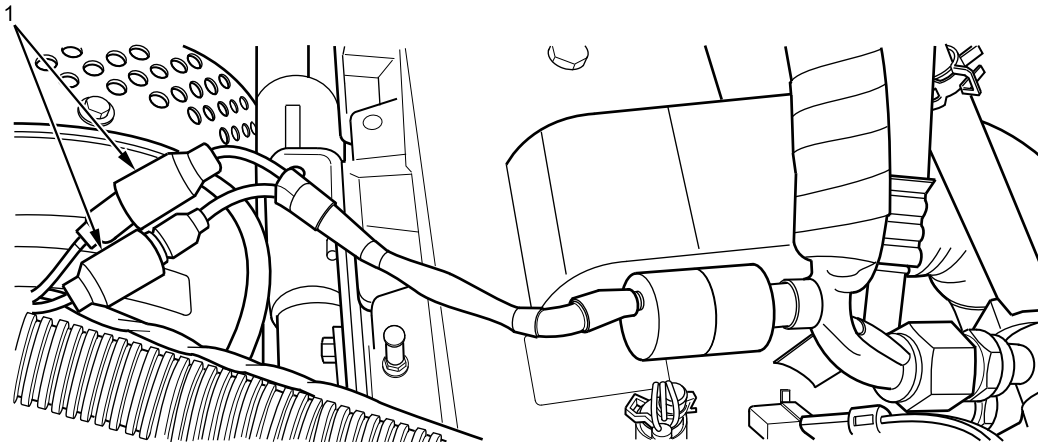

B235202509

Figure 8. Low Pressure Switch Connector.

2. Connect harness connectors (Figure 8, Item 1) at low pressure switch.

HEATING VENTILATING AND AIR CONDITIONING (HVAC)/LIFE SUPPORT SYSTEM (LSS) ENGINE WIRING HARNESS REMOVAL AND INSTALLATION - (CONTINUED)

3. Connect high idle request circuit harness connector (Figure 9, Item 1).

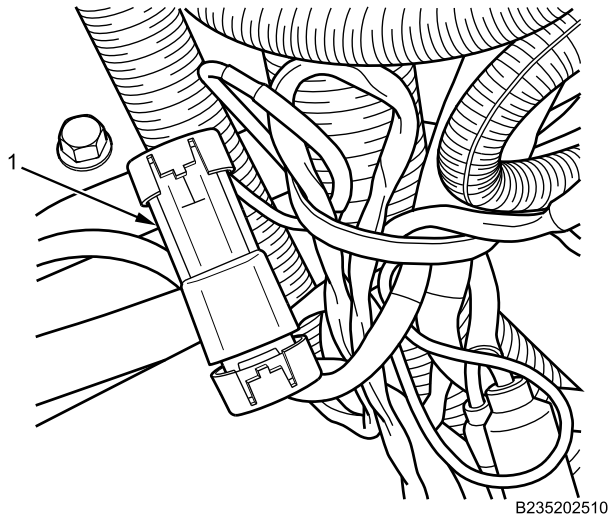

Figure 9. High Idle Request Circuit Connector.

4. Connect harness connectors (Figure 10, Item 1) at 3-way valve.

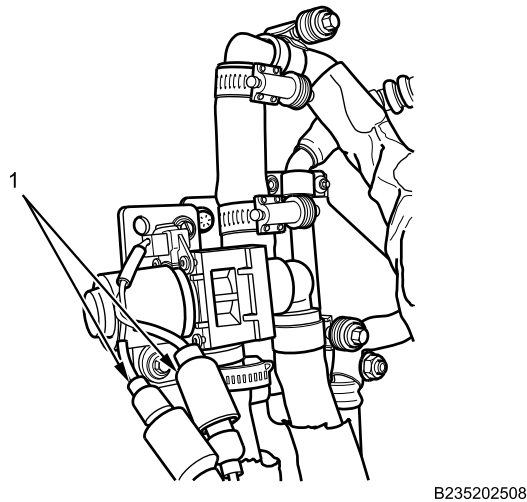

Figure 10. 3-Way Valve.

HEATING VENTILATING AND AIR CONDITIONING (HVAC)/LIFE SUPPORT SYSTEM (LSS) ENGINE WIRING HARNESS REMOVAL AND INSTALLATION - (CONTINUED)

5. Install new O-ring (Figure 11, Item 1) on HVAC/LSS engine harness connector (Figure 11, Item 2).

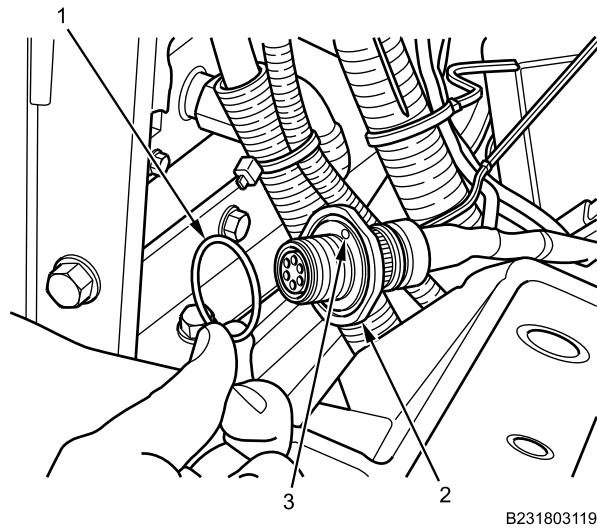

Figure 11. HVAC/LSS Engine Harness O-Ring.

6. Align locator pin (Figure 11, Item 3) on HVAC/LSS engine harness connector (Figure 12, Item 1) with hole in penetration dust plate (Figure 12, Item 2) and connect.

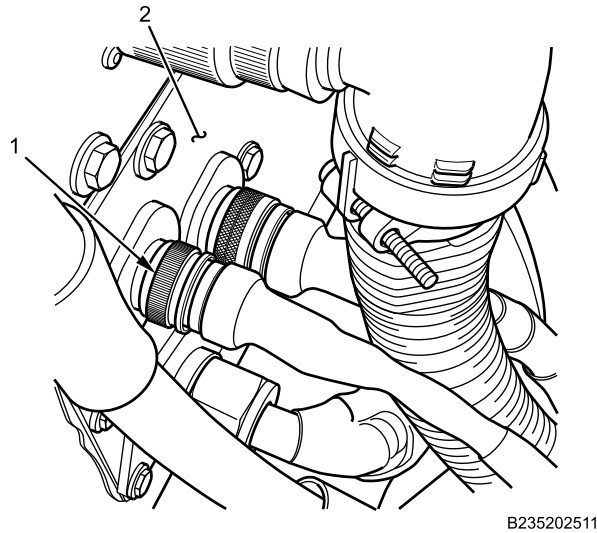
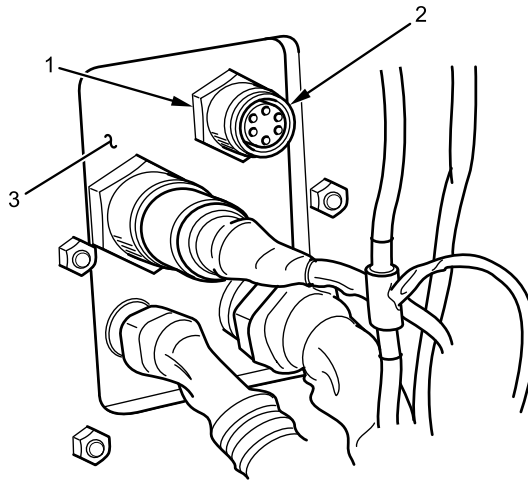

Figure 12. Penetration Plate.

HEATING VENTILATING AND AIR CONDITIONING (HVAC)/LIFE SUPPORT SYSTEM (LSS) ENGINE WIRING HARNESS REMOVAL AND INSTALLATION - (CONTINUED)

- Install nut (Figure 13, Item 1) on HVAC/LSS engine harness connector (Figure 13, Item 2) at penetration dust plate (Figure 13, Item 3). Tighten nut securely.



B239102898

Figure 13. Interior HVAC/LSS Wiring Harness.

- Install interior harness connector (Figure 14, Item 2) to HVAC/LSS engine wiring harness (Figure 14, Item 3) at penetration dust plate (Figure 14, Item 1).

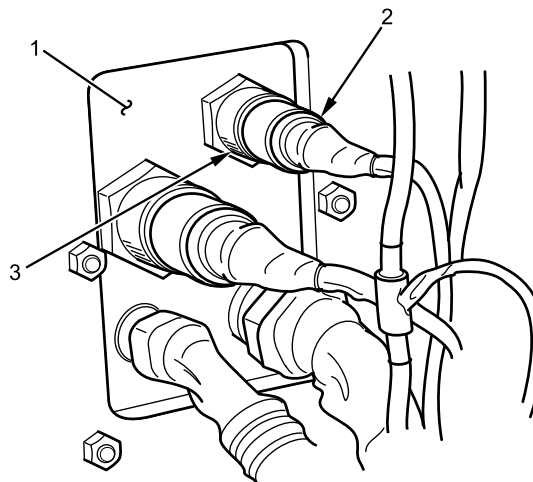

B239102897

Figure 14. Interior Penetration Plate.

- Install new cable lock straps and tighten securely.

END OF TASK

FOLLOW-ON MAINTENANCE

- Turn MAIN POWER switch on (TM 9-2355-106-10).
- Start engine (TM 9-2355-106-10).

HEATING VENTILATING AND AIR CONDITIONING (HVAC)/LIFE SUPPORT SYSTEM (LSS) ENGINE WIRING HARNESS REMOVAL AND INSTALLATION - (CONTINUED)

3. Turn on HVAC/LSS to check for proper operation (TM 9-2355-106-10).
4. Turn off HVAC/LSS (TM 9-2355-106-10).
5. Turn engine off (TM 9-2355-106-10).
6. Turn MAIN POWER switch off (TM 9-2355-106-10).
7. Close and secure right door (WP 0608).
8. Close engine hood (TM 9-2355-106-10).
9. Remove wheel chocks (TM 9-2355-106-10).

END OF TASK

END OF WORK PACKAGE

FIELD MAINTENANCE
HEATING VENTILATING AND AIR CONDITIONING (HVAC) CONTROL INPUT WIRING HARNESS REMOVAL AND INSTALLATION

INITIAL SETUP:**Tools and Special Tools**

General Mechanic's Tool Kit (GMTK)
(WP 0795, Item 37)

WP 0786

WP 0782

Materials/Parts

Cable lock strap - (4) (WP 0796, Item 134)

Equipment Condition

Parking brake set (TM 9-2355-106-10)

Transmission set in NEUTRAL (N) (TM
9-2355-106-10)

Engine off (TM 9-2355-106-10)

MAIN POWER switch off (TM 9-2355-106-10)

Wheels chocked (TM 9-2355-106-10)

References

TM 9-2355-106-10

TM 9-2355-106-23P

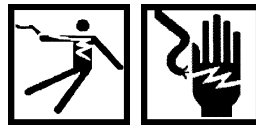
WARNING

Use extreme caution when testing or working on or around electrical circuits. Always assume that electrical circuits are live. Electrical shock can occur upon contact with voltage high enough to cause current flow through muscles or nerves. On Direct Current (DC) systems, generally 1 milliamp of current can be felt, 5 milliamps can cause severe pain, 15 milliamps can cause loss of muscle control, and 70 milliamps can be fatal. Wear protective clothing; ensure skin, clothing, and surrounding areas are dry; do not wear jewelry; and touch only the insulated, nonmetallic parts of electrical components and testing equipment. To prevent electrical arcing, avoid shorting electrical test probes and jumper wires. Electrical arcing can cause bright flashes of light, capable of causing temporary blindness. If electrical injury occurs, immediately shut off power supply and seek medical assistance. Failure to comply may result in serious injury or death to personnel.

HEATING VENTILATING AND AIR CONDITIONING (HVAC) CONTROL INPUT WIRING HARNESS REMOVAL AND INSTALLATION - (CONTINUED)

REMOVAL

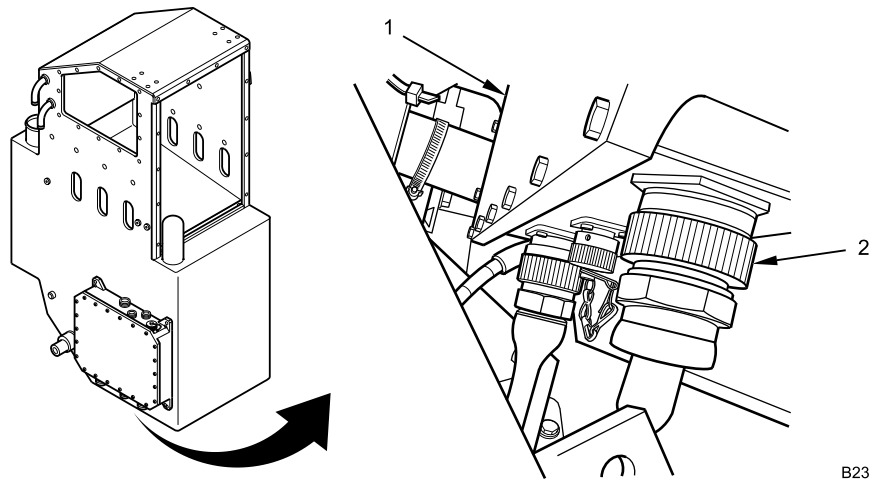

B230604979

Figure 1. HVAC/LSS Control Input Wiring Harness Connections at Climate Control Unit (CCU) Box.

1. Twisting counterclockwise, disconnect HVAC/LSS control input wiring harness connector (Figure 1, Item 2) from CCU box (Figure 1, Item 1).

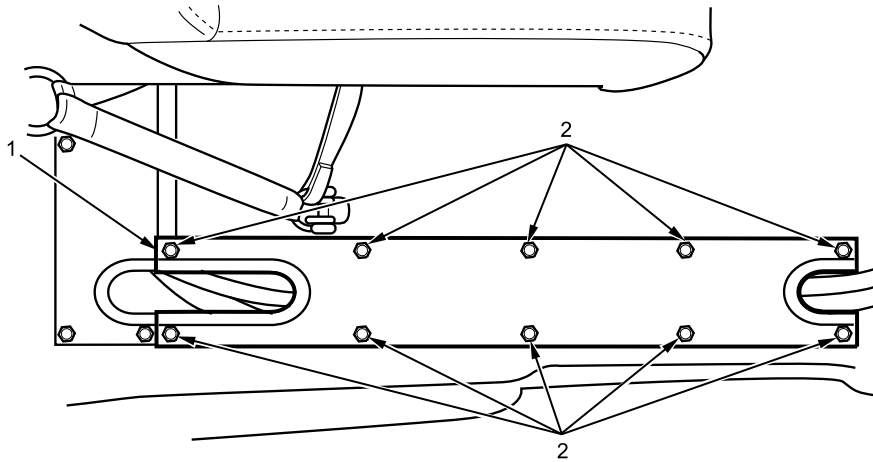

B235201541

Figure 2. Right HVAC Channel Cover.

2. Remove 10 bolts (Figure 2, Item 2) and right channel cover (Figure 2, Item 1).

HEATING VENTILATING AND AIR CONDITIONING (HVAC) CONTROL INPUT WIRING HARNESS REMOVAL AND INSTALLATION - (CONTINUED)

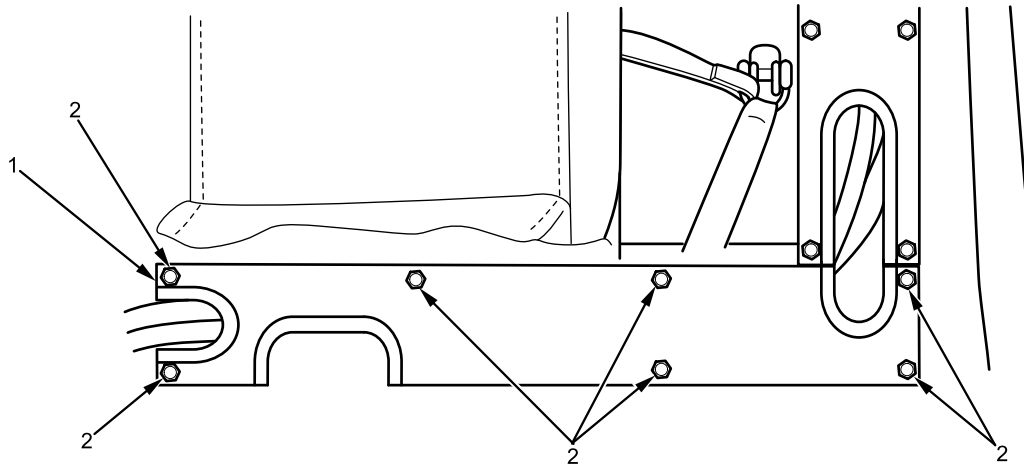

B235201542

Figure 3. Rear HVAC Channel Cover.

3. Remove seven bolts (Figure 3, Item 2) and rear channel cover (Figure 3, Item 1).

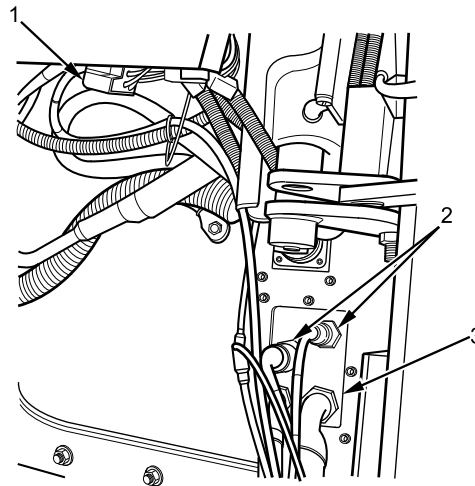

B239102078

Figure 4. HVAC Condenser Relay Harness Connector.

4. Disconnect HVAC condenser relay harness connector (Figure 4, Item 1). Remove and discard cable lock straps as necessary.
5. Twisting counterclockwise, disconnect two electrical connectors (Figure 4, Item 2) at penetration dust plate (Figure 4, Item 3) and remove HVAC/LSS control input wiring harness.

END OF TASK

HEATING VENTILATING AND AIR CONDITIONING (HVAC) CONTROL INPUT WIRING HARNESS REMOVAL AND INSTALLATION - (CONTINUED)

INSTALLATION

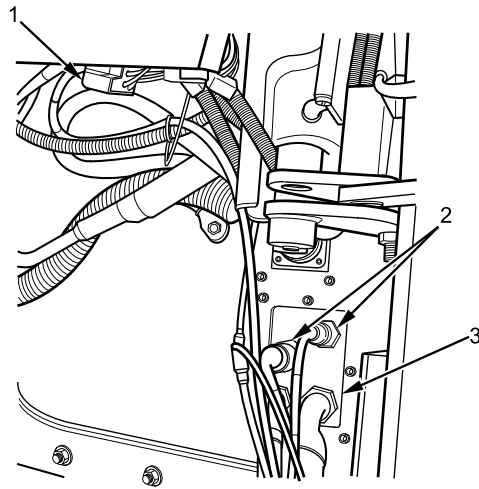

B239102078

Figure 5. HVAC Condenser Relay Harness Connector.

1. Connect HVAC condenser relay harness connector (Figure 5, Item 1). Install new cable lock straps as necessary.
2. Connect two electrical connectors (Figure 5, Item 2) at penetration dust plate (Figure 5, Item 3) by twisting clockwise until secure.
3. Install the HVAC/LSS control input wiring harness into HVAC channel.

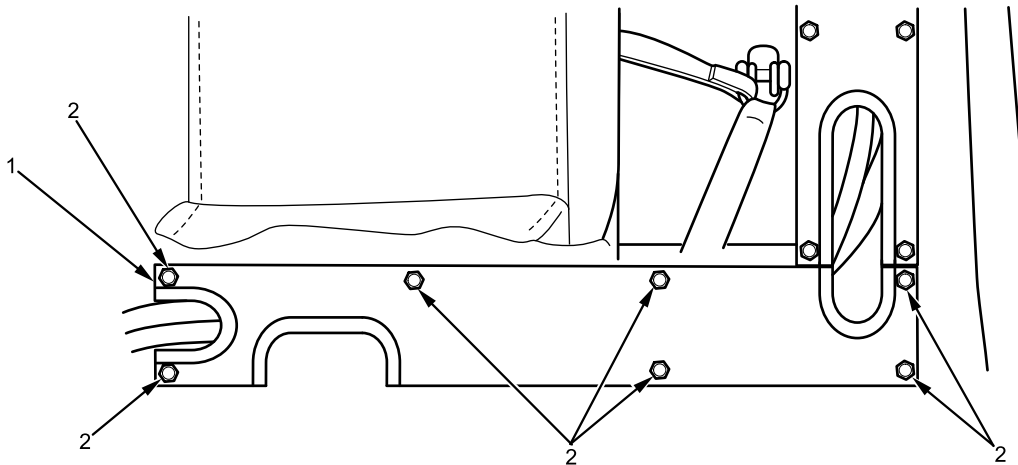

B235201542

Figure 6. Rear HVAC Channel Cover.

4. Install rear channel cover (Figure 6, Item 1) with seven bolts (Figure 6, Item 2). Tighten bolts securely.

HEATING VENTILATING AND AIR CONDITIONING (HVAC) CONTROL INPUT WIRING HARNESS REMOVAL AND INSTALLATION - (CONTINUED)

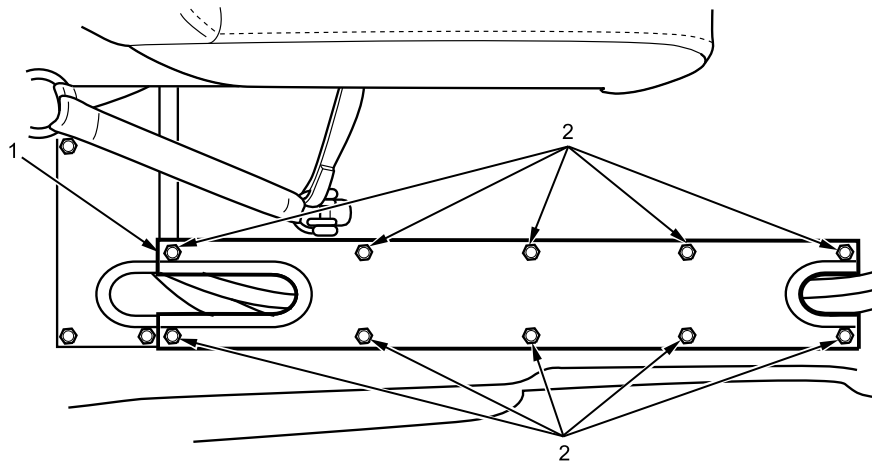

B235201541

Figure 7. Right HVAC Channel Cover.

5. Install right channel cover (Figure 7, Item 1) with 10 bolts (Figure 7, Item 2). Tighten bolts securely.

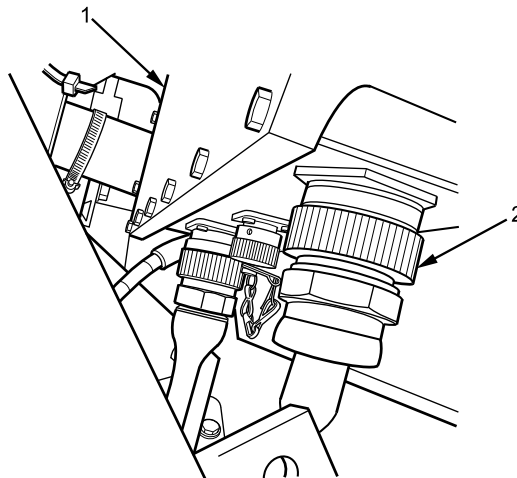

B239102077

Figure 8. HVAC/LSS Control Input Wiring Harness Connections at Climate Control Unit (CCU) Box.

6. Connect HVAC/LSS control input wiring harness connector (Figure 8, Item 2) on CCU box (Figure 8, Item 1) by twisting clockwise until secure.

END OF TASK

HEATING VENTILATING AND AIR CONDITIONING (HVAC) CONTROL INPUT WIRING HARNESS REMOVAL AND INSTALLATION - (CONTINUED)**FOLLOW-ON MAINTENANCE**

1. Turn MAIN POWER switch on (TM 9-2355-106-10).
2. Start engine (TM 9-2355-106-10).
3. Close all doors and hatches securely (TM 9-2355-106-10).
4. Turn on HVAC/LSS to verify proper operation (TM 9-2355-106-10).
5. Turn off HVAC/LSS (TM 9-2355-106-10).
6. Turn engine off (TM 9-2355-106-10).
7. Turn MAIN POWER switch off (TM 9-2355-106-10).
8. Remove wheel chocks (TM 9-2355-106-10).

END OF TASK**END OF WORK PACKAGE**

FIELD MAINTENANCE
HEATING VENTILATING AND AIR CONDITIONING (HVAC) CONTROL 2 WIRING HARNESS REMOVAL AND INSTALLATION

INITIAL SETUP:**Tools and Special Tools**

General Mechanic's Tool Kit (GMTK)
(WP 0795, Item 37)

WP 0786

WP 0782

Materials/Parts

Grease (WP 0794, Item 22)
Wire tags (WP 0794, Item 33)
Cable lock strap - (8) (WP 0796, Item 134)

Equipment Condition

Parking brake set (TM 9-2355-106-10)
Transmission set in NEUTRAL (N) (TM 9-2355-106-10)
Engine off (TM 9-2355-106-10)
MAIN POWER switch off (TM 9-2355-106-10)
Wheels chocked (TM 9-2355-106-10)
Engine hood open and secured (TM 9-2355-106-10)
Right cabin door secured safely open (WP 0608)

References

TM 9-2355-106-10
TM 9-2355-106-23P

WARNING

Use extreme caution when testing or working on or around electrical circuits. Always assume that electrical circuits are live. Electrical shock can occur upon contact with voltage high enough to cause current flow through muscles or nerves. On Direct Current (DC) systems, generally 1 milliamp of current can be felt, 5 milliamps can cause severe pain, 15 milliamps can cause loss of muscle control, and 70 milliamps can be fatal. Wear protective clothing; ensure skin, clothing, and surrounding areas are dry; do not wear jewelry; and touch only the insulated, nonmetallic parts of electrical components and testing equipment. To prevent electrical arcing, avoid shorting electrical test probes and jumper wires. Electrical arcing can cause bright flashes of light, capable of causing temporary blindness. If electrical injury occurs, immediately shut off power supply and seek medical assistance. Failure to comply may result in serious injury or death to personnel.

Cabin door must be secured in the open position by using heavy duty straps to prevent accidental closure during vehicle maintenance. Pull door hinge pin prior to securing door open. Failure to comply may result in serious injury or death to personnel.

Use the appropriate lifting strap sling or chain hoist for the type of load. Always clean and inspect lifting strap slings and chain hoists prior to use. Inspect for damage such as wear, corrosion, elongation, tears, or punctures. Replace lifting strap slings or chain hoists that are damaged. Failure to comply may result in component damage and death or injury to personnel.

Engine hood is extremely heavy and requires two-person lift. Ensure that there is adequate space in front of the vehicle to open hood completely without pinning or pinching personnel between hood and any other structure. Use extreme care when working under hood and make sure it is properly supported. Failure to comply may result in serious injury or death to personnel.

HEATING VENTILATING AND AIR CONDITIONING (HVAC) CONTROL 2 WIRING HARNESS REMOVAL AND INSTALLATION - (CONTINUED)

NOTE

Remove cable lock straps as necessary to perform procedure. Note position and size of cable lock straps to aid installation.

Label all wires before removal to facilitate installation.

REMOVAL

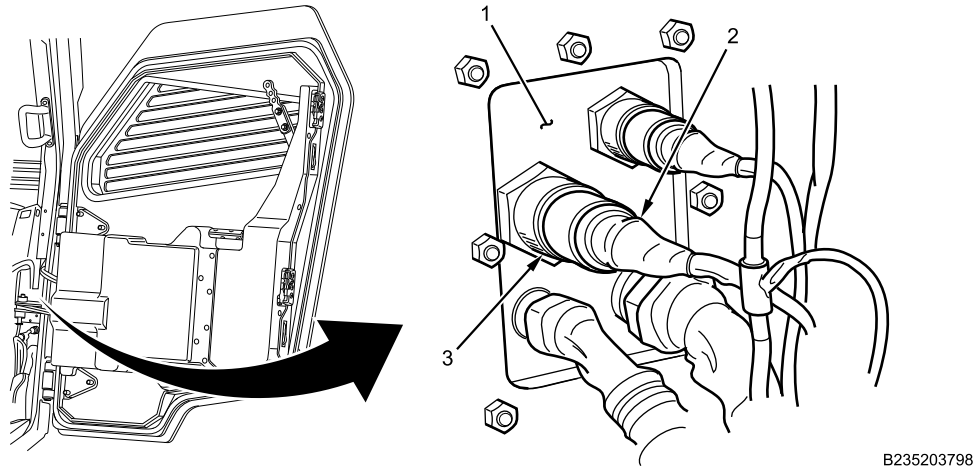

Figure 1. Interior Pass-Through Plate.

1. Disconnect interior wiring harness connector (Figure 1, Item 2) from HVAC control 2 wiring harness connector (Figure 1, Item 3) at interior pass-through plate (Figure 1, Item 1).

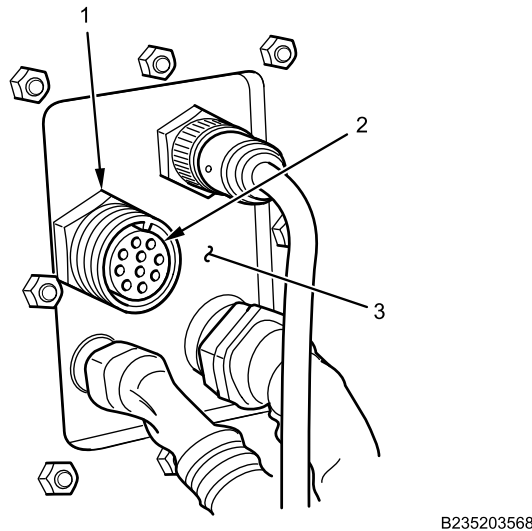
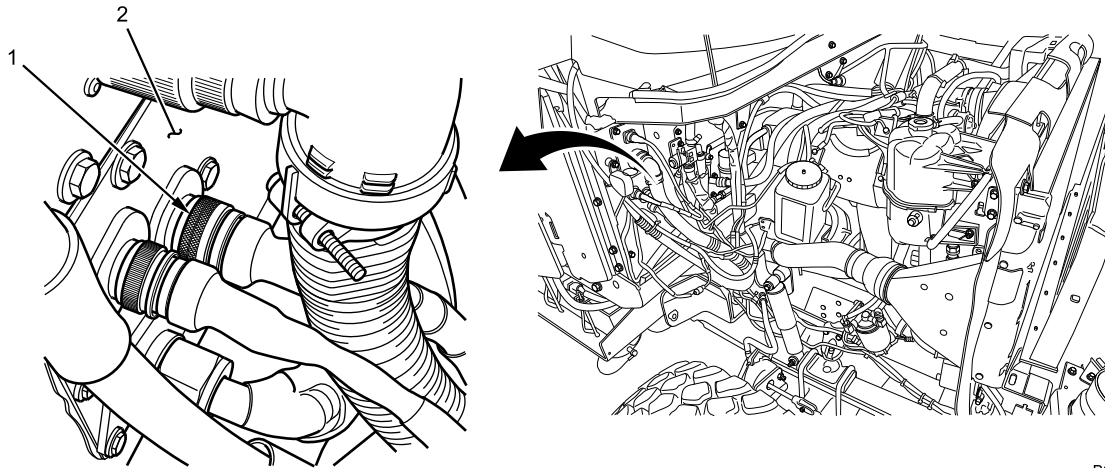

Figure 2. Interior HVAC Control 2 Wiring Harness Connector.

2. Remove nut (Figure 2, Item 1) from HVAC control 2 engine wiring harness connector (Figure 2, Item 2) at interior pass-through plate (Figure 2, Item 3).

HEATING VENTILATING AND AIR CONDITIONING (HVAC) CONTROL 2 WIRING HARNESS REMOVAL AND INSTALLATION - (CONTINUED)



B235203799

Figure 3. Exterior Pass-Through Plate.

3. Remove HVAC control 2 wiring harness connector (Figure 3, Item 1) from exterior pass-through plate (Figure 3, Item 2).

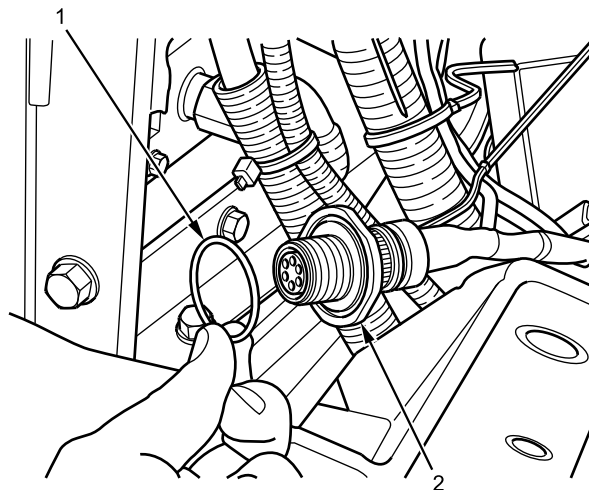

B239102899

Figure 4. HVAC Control 2 Wiring Harness O-Ring.

4. Remove O-ring (Figure 4, Item 1) from HVAC control 2 wiring harness connector (Figure 4, Item 2) and inspect O-ring for cuts or cracks. If cuts or cracks are found, replace harness.

HEATING VENTILATING AND AIR CONDITIONING (HVAC) CONTROL 2 WIRING HARNESS REMOVAL AND INSTALLATION - (CONTINUED)

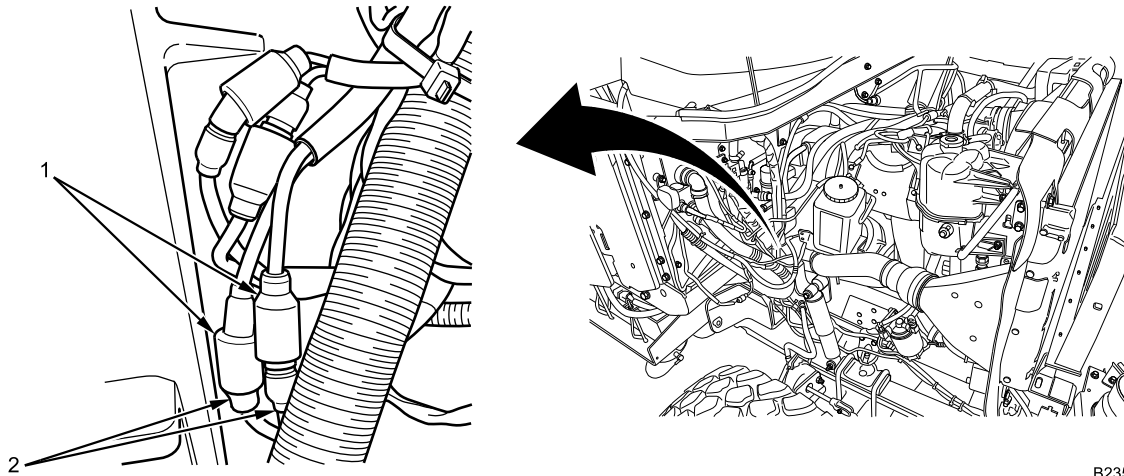

B235203800

Figure 5. Left Condenser Harness Connectors.

5. Disconnect left condenser harness connectors (Figure 5, Item 1) from HVAC control 2 wiring harness connectors (Figure 5, Item 2).

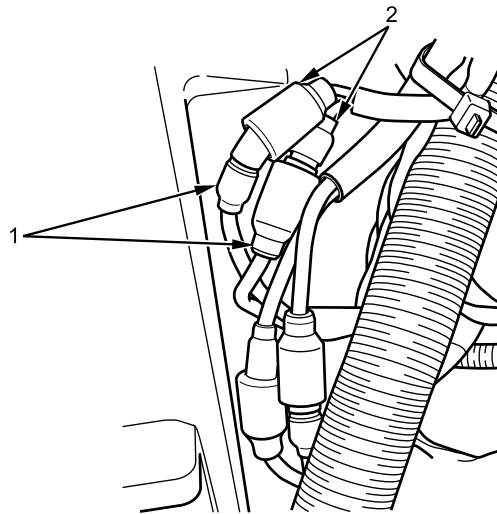

B235202485

Figure 6. Right Condenser Harness Connectors.

6. Disconnect HVAC control 2 wiring harness connectors (Figure 6, Item 1) from right condenser harness connectors (Figure 6, Item 2).
7. Disconnect HVAC compressor connector (Figure 7, Item 2) from HVAC control 2 wiring harness (Figure 7, Item 1). Remove HVAC control 2 wiring harness.

HEATING VENTILATING AND AIR CONDITIONING (HVAC) CONTROL 2 WIRING HARNESS REMOVAL AND INSTALLATION - (CONTINUED)

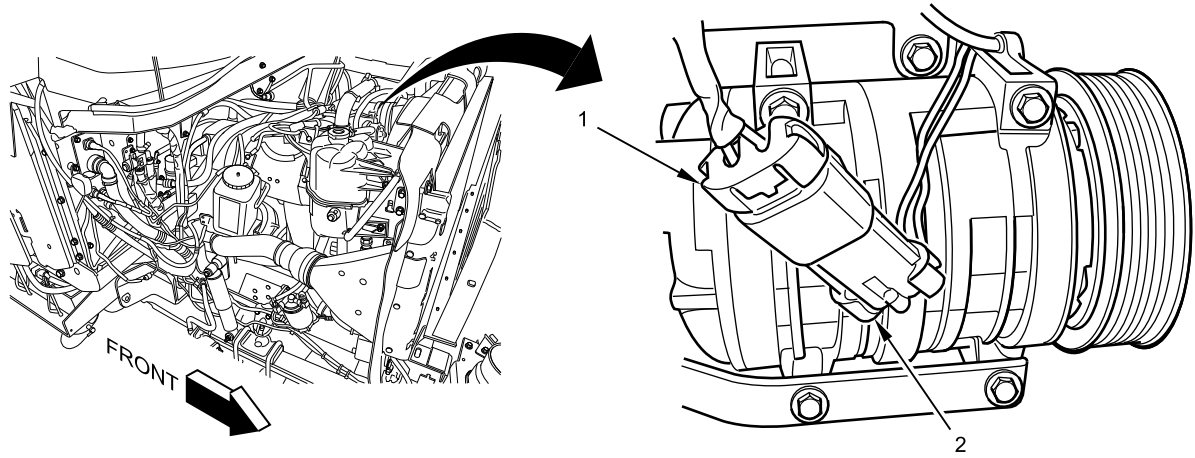

B230612269

Figure 7. HVAC Compressor Connector.

END OF TASK

HEATING VENTILATING AND AIR CONDITIONING (HVAC) CONTROL 2 WIRING HARNESS REMOVAL AND INSTALLATION - (CONTINUED)

INSTALLATION

WARNING



Dielectric grease is harmful to skin and eyes. If grease contacts eyes, rinse thoroughly and contact physician if irritation persists. If skin is contacted, wash thoroughly with soap and water. Failure to comply may result in serious injury to personnel.

NOTE

Apply dielectric grease to all HVAC control 2 wiring harness electrical connections before installation.

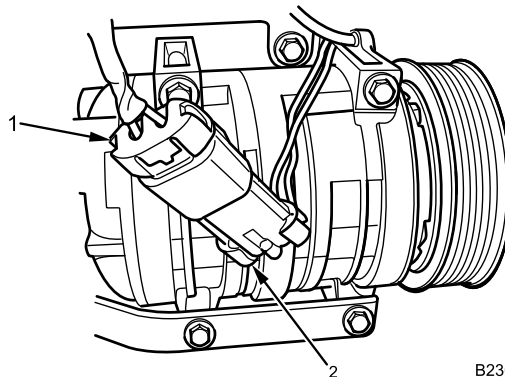

B230610198

Figure 8. HVAC Compressor Harness Connector.

1. Connect HVAC control 2 wiring harness (Figure 8, Item 1) to HVAC compressor connector (Figure 8, Item 2).

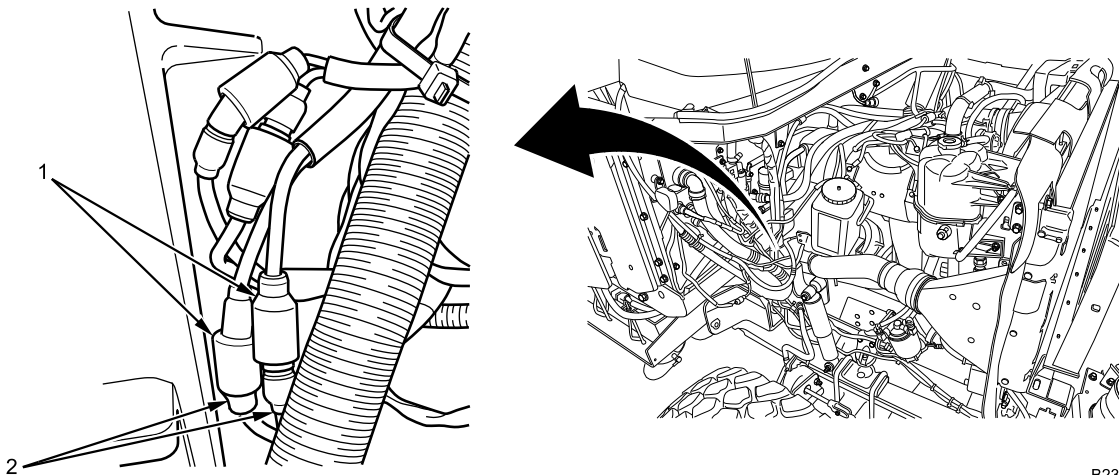

B235203800

Figure 9. Left Condenser Connectors.

2. Connect HVAC control 2 wiring harness connectors (Figure 9, Item 2) to left condenser harness connectors (Figure 9, Item 1).

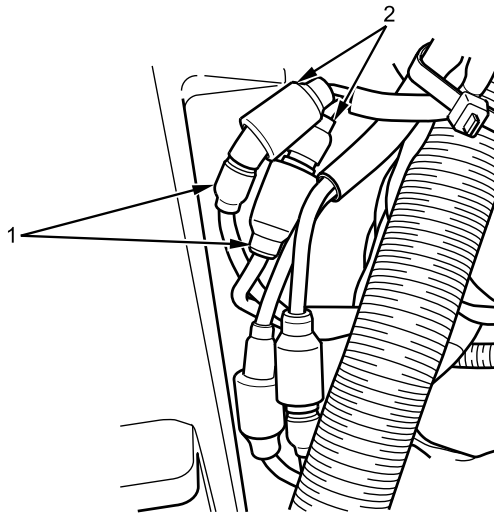
HEATING VENTILATING AND AIR CONDITIONING (HVAC) CONTROL 2 WIRING HARNESS REMOVAL AND INSTALLATION - (CONTINUED)

B235202485

Figure 10. Right Condenser Connectors.

3. Connect HVAC control 2 wiring harness connectors (Figure 10, Item 1) to right condenser harness connectors (Figure 10, Item 2).

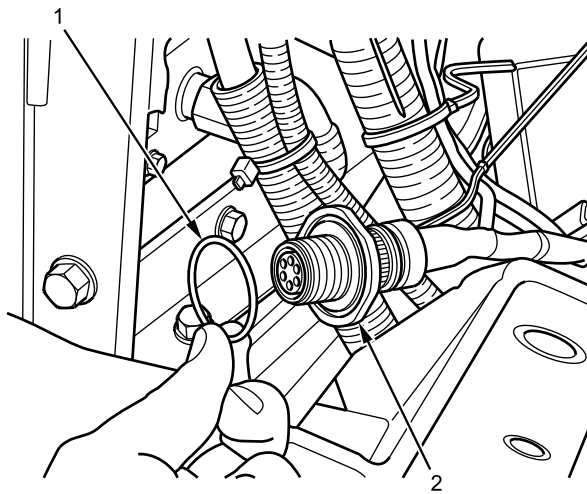

B239102899

Figure 11. HVAC Control 2 Harness O-Ring.

4. Install O-ring (Figure 11, Item 1) on HVAC control 2 wiring harness connector (Figure 11, Item 2).

HEATING VENTILATING AND AIR CONDITIONING (HVAC) CONTROL 2 WIRING HARNESS REMOVAL AND INSTALLATION - (CONTINUED)

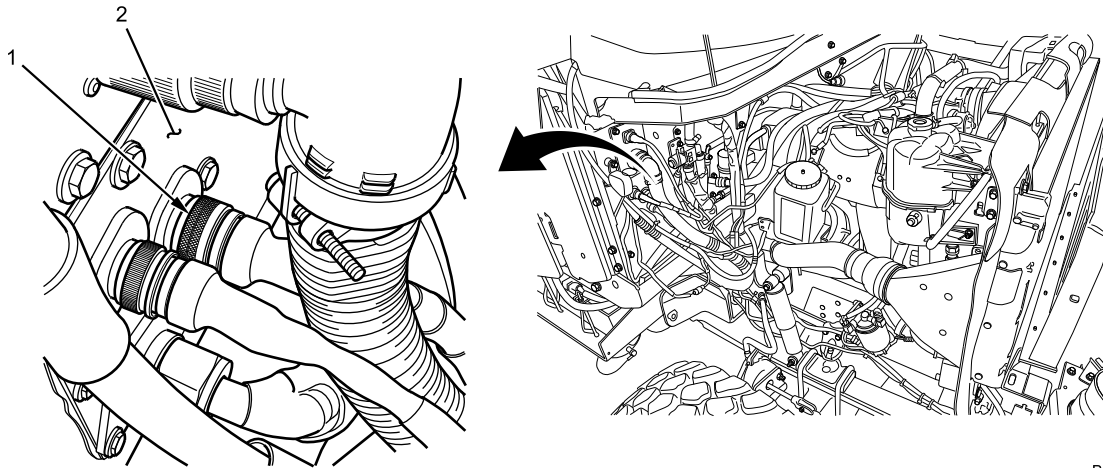

B235203799

Figure 12. Exterior Pass-Through Plate.

5. Insert HVAC control 2 wiring harness connector (Figure 12, Item 1) through hole on exterior pass-through plate (Figure 12, Item 2).

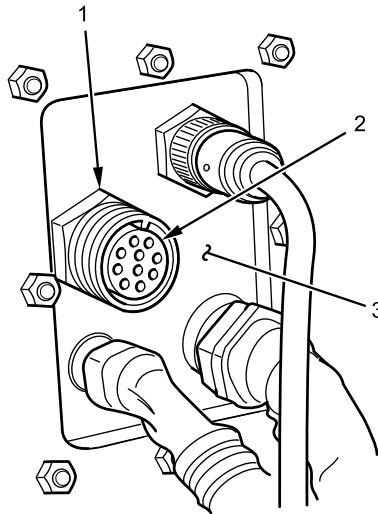

B235203568

Figure 13. Interior HVAC Wiring Harness Connector.

NOTE

Ensure O-ring remains in position when installing nut.

6. Install nut (Figure 13, Item 1) on HVAC control 2 wiring harness connector (Figure 13, Item 2) at interior pass-through plate (Figure 13, Item 3). Tighten nut securely.

HEATING VENTILATING AND AIR CONDITIONING (HVAC) CONTROL 2 WIRING HARNESS REMOVAL AND INSTALLATION - (CONTINUED)

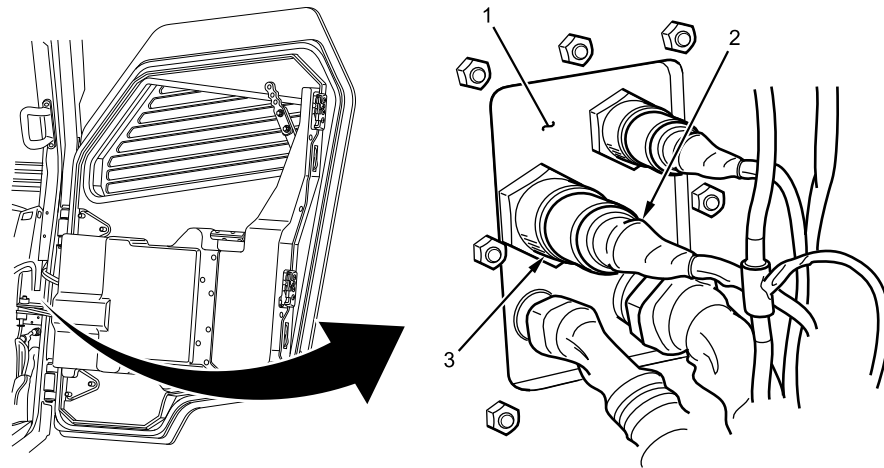

B235203798

Figure 14. Interior Pass-Through Plate.

7. Install interior wiring harness connector (Figure 14, Item 2) on HVAC control 2 wiring harness connector (Figure 14, Item 3) at interior pass-through plate (Figure 14, Item 1).
8. Install all cable lock straps and tighten securely.

END OF TASK

FOLLOW-ON MAINTENANCE

1. Close and secure right cabin door (WP 0608).
2. Close engine hood (TM 9-2355-106-10).
3. Turn MAIN POWER switch on (TM 9-2355-106-10).
4. Start engine (TM 9-2355-106-10).
5. Turn on HVAC/LSS to check for proper operation (TM 9-2355-106-10).
6. Turn off HVAC/LSS (TM 9-2355-106-10).
7. Turn engine off (TM 9-2355-106-10).
8. Turn MAIN POWER switch off (TM 9-2355-106-10).
9. Remove wheel chocks (TM 9-2355-106-10).

END OF TASK

END OF WORK PACKAGE

FIELD MAINTENANCE
**HEATING VENTILATING AND AIR CONDITIONING (HVAC)/LIFE SUPPORT SYSTEM (LSS) CONTROL
POWER WIRING HARNESS REMOVAL AND INSTALLATION**

INITIAL SETUP:**Tools and Special Tools**

General Mechanic's Tool Kit (GMTK)
(WP 0795, Item 37)

WP 0786

WP 0782

Materials/Parts

Grease (WP 0794, Item 22)
Wire - 6 ft (1.8 m) (WP 0794, Item 57)
Cable lock straps - (6) (WP 0796, Item 134)

Equipment Condition

Parking brake set (TM 9-2355-106-10)
Transmission set in NEUTRAL (N) (TM
9-2355-106-10)
Engine off (TM 9-2355-106-10)
Wheels chocked (TM 9-2355-106-10)
MAIN POWER switch off (TM 9-2355-106-10)
Transmission auto shift control module removed
(WP 0452)

References

TM 9-2355-106-10
TM 9-2355-106-23P

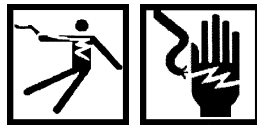
WARNING

Use extreme caution when testing or working on or around electrical circuits. Always assume that electrical circuits are live. Electrical shock can occur upon contact with voltage high enough to cause current flow through muscles or nerves. On Direct Current (DC) systems, generally 1 milliamp of current can be felt, 5 milliamps can cause severe pain, 15 milliamps can cause loss of muscle control, and 70 milliamps can be fatal. Wear protective clothing; ensure skin, clothing, and surrounding areas are dry; do not wear jewelry; and touch only the insulated, nonmetallic parts of electrical components and testing equipment. To prevent electrical arcing, avoid shorting electrical test probes and jumper wires. Electrical arcing can cause bright flashes of light, capable of causing temporary blindness. If electrical injury occurs, immediately shut off power supply and seek medical assistance. Failure to comply may result in serious injury or death to personnel.

HEATING VENTILATING AND AIR CONDITIONING (HVAC)/LIFE SUPPORT SYSTEM (LSS) CONTROL POWER WIRING HARNESS REMOVAL AND INSTALLATION - (CONTINUED)

REMOVAL

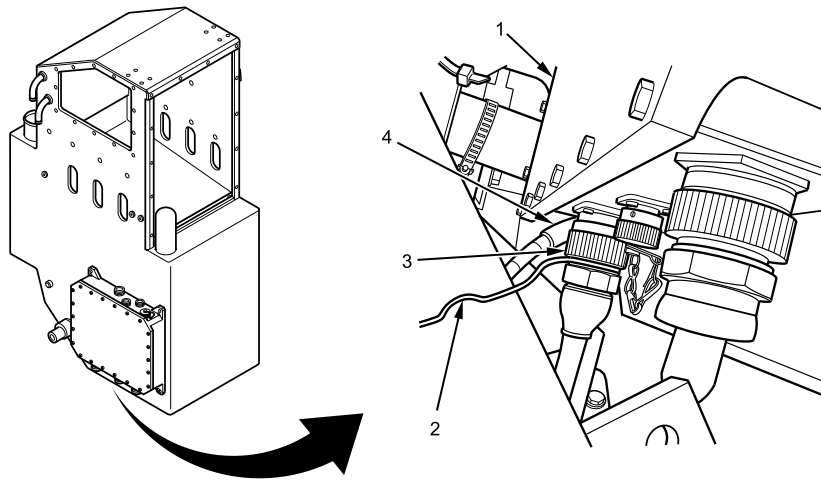

B230604923

Figure 1. HVAC/LSS Control Power Wiring Harness Connection at Climate Control Unit (CCU) Box.

1. Twisting counterclockwise, disconnect HVAC/LSS control power wiring harness connector (Figure 1, Item 3) from CCU box (Figure 1, Item 1).
2. Remove nut that attaches ground cable (Figure 1, Item 4) to CCU box (Figure 1, Item 1). Nut hidden from view.

NOTE

Mechanic's wire will be used to pull wiring harness under radio tray.

3. Connect one end of mechanic's wire (Figure 1, Item 2) behind control power wiring harness connector (Figure 1, Item 3).

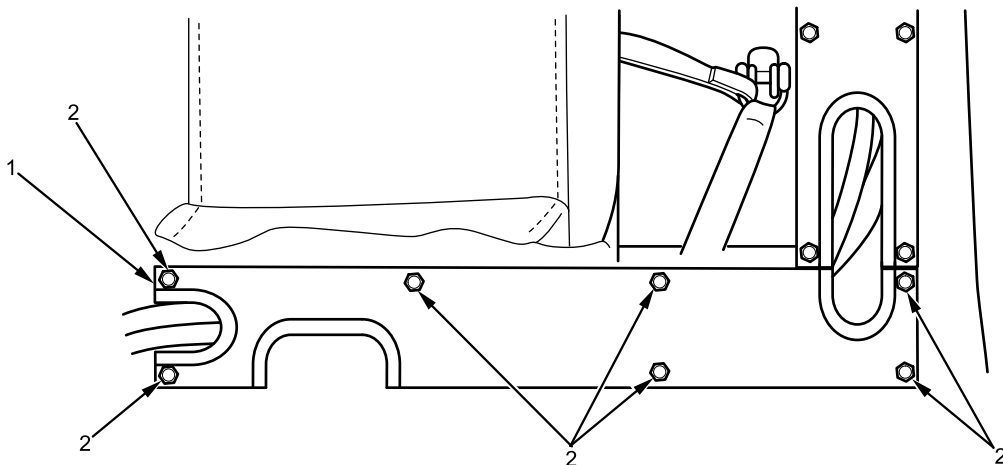

B235201542

Figure 2. Rear HVAC Channel Cover.

4. Remove seven bolts (Figure 2, Item 2) and rear channel cover (Figure 2, Item 1).

**HEATING VENTILATING AND AIR CONDITIONING (HVAC)/LIFE SUPPORT SYSTEM (LSS) CONTROL
POWER WIRING HARNESS REMOVAL AND INSTALLATION - (CONTINUED)**

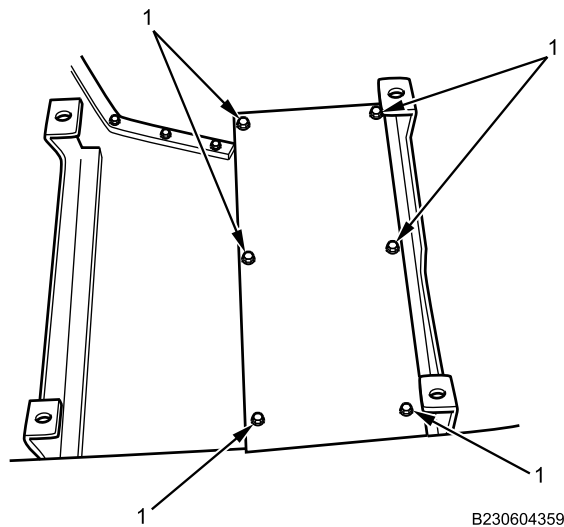

Figure 3. Electrical Harness Storage Duct Cover.

5. Remove six bolts (Figure 3, Item 1) from electrical harness storage duct cover (Figure 3, Item 2) and remove electrical harness storage duct cover.

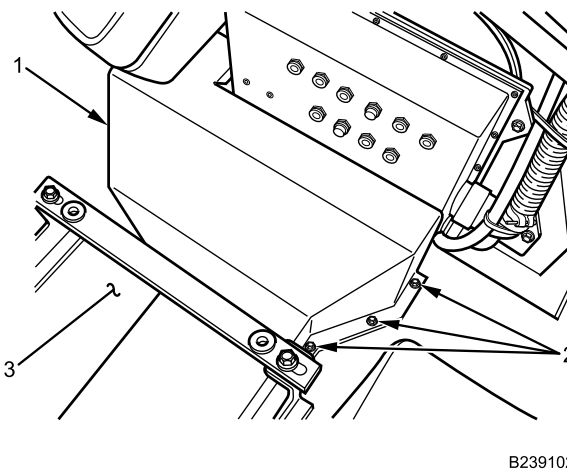

Figure 4. Power Distribution Module (PDM) Harness Electrical Storage Shield.

6. Remove eight bolts (Figure 4, Item 2) from power distribution module (PDM) harness electrical storage shield (Figure 4, Item 1). Three bolts shown. Five bolts hidden from view.
7. Remove PDM harness electrical storage shield (Figure 4, Item 1) from floor (Figure 4, Item 3).

NOTE

Note locations of cable lock straps to aid installation.

8. Cut and discard cable lock straps as necessary to remove harness.

HEATING VENTILATING AND AIR CONDITIONING (HVAC)/LIFE SUPPORT SYSTEM (LSS) CONTROL POWER WIRING HARNESS REMOVAL AND INSTALLATION - (CONTINUED)

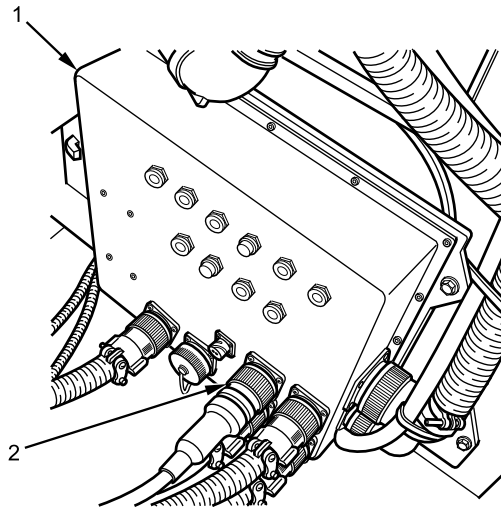

B239102115

Figure 5. HVAC/LSS Control Power Wiring Harness Connection at PDM.

9. Twisting counterclockwise, remove HVAC/LSS control power wiring harness connector (Figure 5, Item 2) from PDM (Figure 5, Item 1).

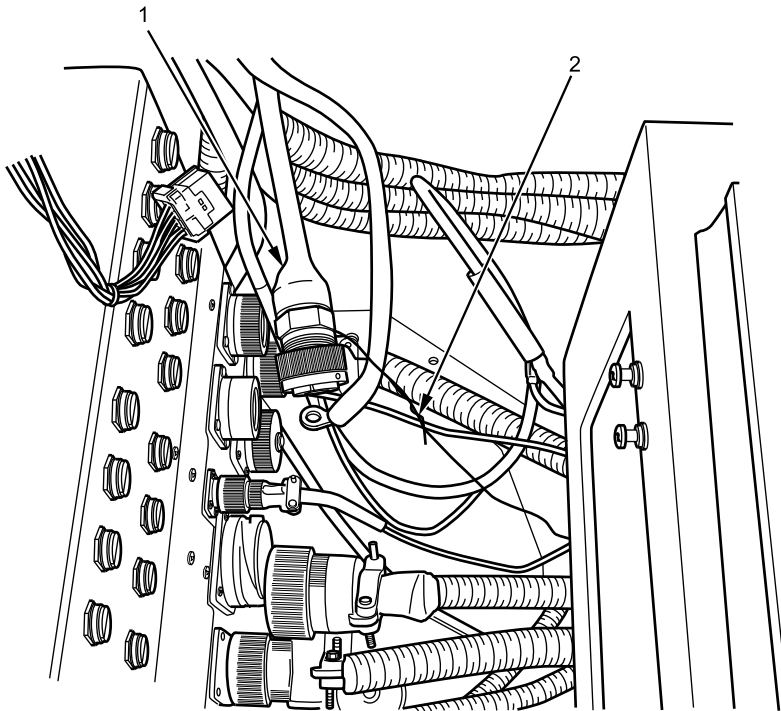

B230603256

Figure 6. HVAC/LSS Control Power Wiring Harness Routing with Mechanic's Wire.

NOTE

Leave mechanic's wire under government furnished equipment (GFE) tray in order to route harness during installation.

10. Pull HVAC/LSS control power wiring harness (Figure 6, Item 1) under (GFE) tray.

HEATING VENTILATING AND AIR CONDITIONING (HVAC)/LIFE SUPPORT SYSTEM (LSS) CONTROL POWER WIRING HARNESS REMOVAL AND INSTALLATION - (CONTINUED)

11. Disconnect mechanic's wire (Figure 6, Item 2) from HVAC/LSS control power wiring harness (Figure 6, Item 1), and remove harness from vehicle.

END OF TASK**INSTALLATION****WARNING**

Dielectric grease is harmful to skin and eyes. If grease contacts eyes, rinse thoroughly and contact physician if irritation persists. If skin is contacted, wash thoroughly with soap and water. Failure to comply may result in serious injury to personnel.

NOTE

Apply dielectric grease to all electrical connections.

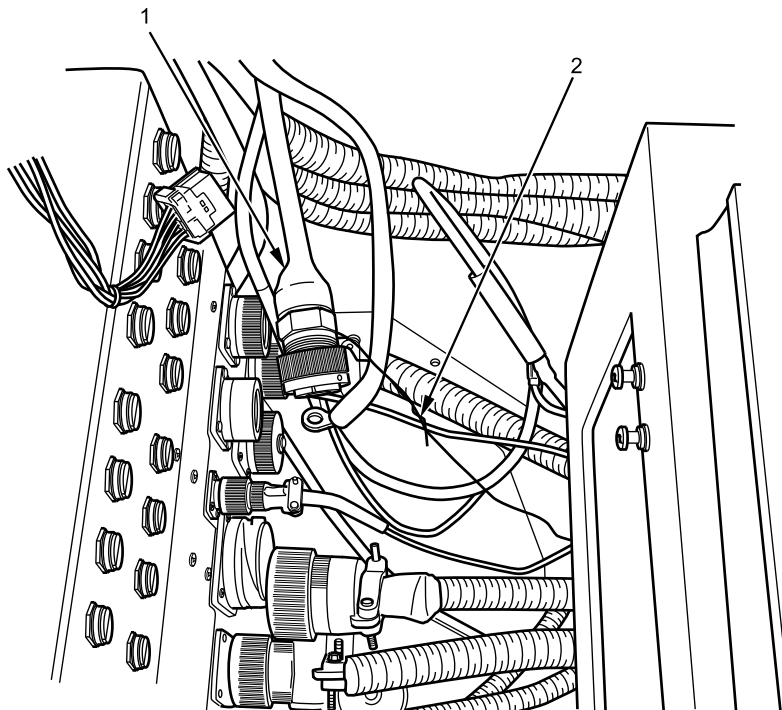

B230603256

Figure 7. HVAC/LSS Control Power Wiring Harness Routing with Mechanic's Wire.

1. Connect end of mechanic's wire (Figure 7, Item 2) to CCU end of HVAC/LSS control power wiring harness (Figure 7, Item 1), and pull harness under government furnished equipment (GFE) tray.

HEATING VENTILATING AND AIR CONDITIONING (HVAC)/LIFE SUPPORT SYSTEM (LSS) CONTROL POWER WIRING HARNESS REMOVAL AND INSTALLATION - (CONTINUED)

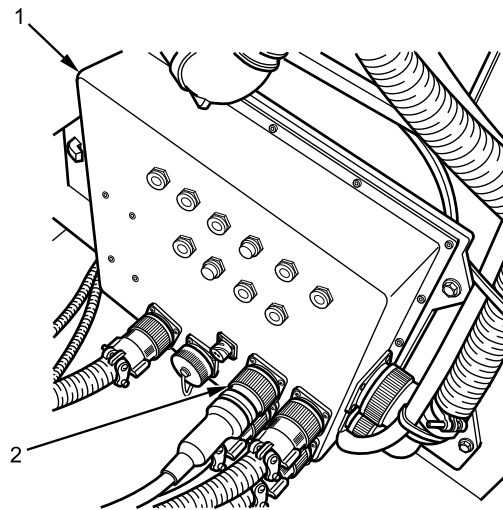

B239102115

Figure 8. HVAC/LSS Control Power Wiring Harness Connection at Circuit Breaker Panel.

2. Connect HVAC/LSS control power wiring harness connector (Figure 8, Item 2) on circuit breaker panel (Figure 8, Item 1) by twisting clockwise until secure.

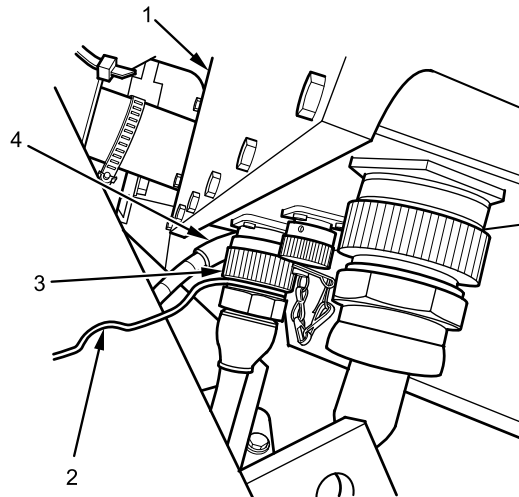

B239102114

Figure 9. HVAC/LSS Control Power Wiring Harness Connection at CCU Box.

3. Remove mechanic's wire (Figure 9, Item 2) from HVAC/LSS control power wiring harness connector (Figure 9, Item 3).
4. Install ground cable (Figure 9, Item 4) on CCU box (Figure 9, Item 1) with nut and tighten securely. Nut hidden from view.
5. Connect HVAC/LSS control power wiring harness connector (Figure 9, Item 3) on CCU box (Figure 9, Item 1) by twisting clockwise until secure.
6. Install new cable lock straps in locations noted during removal.

HEATING VENTILATING AND AIR CONDITIONING (HVAC)/LIFE SUPPORT SYSTEM (LSS) CONTROL POWER WIRING HARNESS REMOVAL AND INSTALLATION - (CONTINUED)

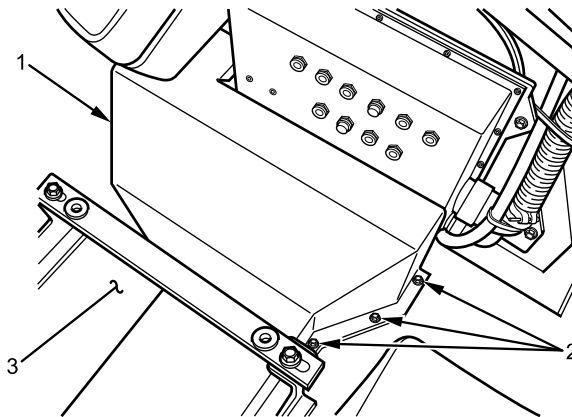

B239102113

Figure 10. Power Distribution Module (PDM) Harness Electrical Storage Shield.

7. Install PDM harness electrical storage shield (Figure 10, Item 1) on floor (Figure 10, Item 3) with eight bolts (Figure 10, Item 2) and tighten securely. Three bolts shown. Five bolts hidden from view.

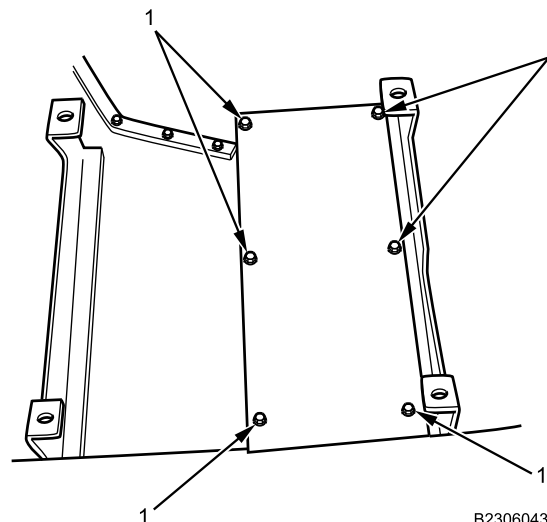

B230604359

Figure 11. Electrical Harness Storage Duct Cover.

8. Install electrical harness storage duct cover (Figure 11, Item 2) with six bolts (Figure 11, Item 1). Tighten bolts securely.

**HEATING VENTILATING AND AIR CONDITIONING (HVAC)/LIFE SUPPORT SYSTEM (LSS) CONTROL
POWER WIRING HARNESS REMOVAL AND INSTALLATION - (CONTINUED)**

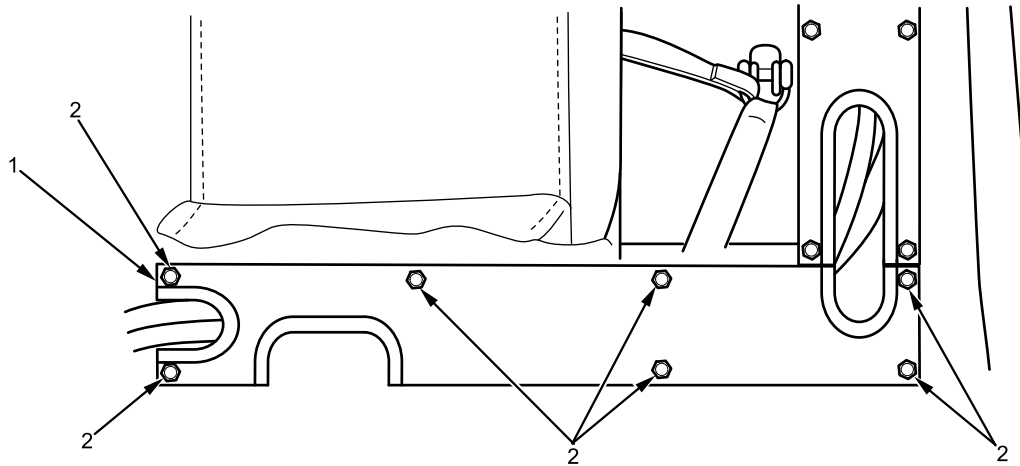

B235201542

Figure 12. Rear HVAC Channel Cover.

9. Install rear channel cover (Figure 12, Item 1) with seven bolts (Figure 12, Item 2). Tighten bolts securely.

END OF TASK

FOLLOW-ON MAINTENANCE

1. Install transmission auto shift control module (WP 0452).
2. Turn MAIN POWER switch on (TM 9-2355-106-10).
3. Start engine (TM 9-2355-106-10).
4. Close all doors and hatches securely (TM 9-2355-106-10).
5. Turn on HVAC/LSS to verify proper operation (TM 9-2355-106-10).
6. Turn off HVAC/LSS (TM 9-2355-106-10).
7. Turn engine off (TM 9-2355-106-10).
8. Turn MAIN POWER switch off (TM 9-2355-106-10).
9. Remove wheel chocks (TM 9-2355-106-10).

END OF TASK

END OF WORK PACKAGE

FIELD MAINTENANCE
HEATING VENTILATING AND AIR CONDITIONING (HVAC)/LIFE SUPPORT SYSTEM (LSS) MAIN BLOWER MOTOR WIRING HARNESS REMOVAL AND INSTALLATION

INITIAL SETUP:**Tools and Special Tools**

General Mechanic's Tool Kit (GMTK)
(WP 0795, Item 37)

Materials/Parts

Grease (WP 0794, Item 22)

References

TM 9-2355-106-10
TM 9-2355-106-23P
WP 0786
WP 0782

Equipment Condition

Parking brake set (TM 9-2355-106-10)

Transmission set in NEUTRAL (N) (TM 9-2355-106-10)

Engine off (TM 9-2355-106-10)

MAIN POWER switch off (TM 9-2355-106-10)

Wheels chocked (TM 9-2355-106-10)

Turn LSS control switch off (TM 9-2355-106-10)

Right side exterior body armor front panel removed (WP 0633)

Nuclear, Biological, and Chemical (NBC) filter removed (WP 0762)

NBC filter cover and housing removed (WP 0763)

NBC particle separator filter removed (WP 0764)

WARNING

Use extreme caution when testing or working on or around electrical circuits. Always assume that electrical circuits are live. Electrical shock can occur upon contact with voltage high enough to cause current flow through muscles or nerves. On Direct Current (DC) systems, generally 1 milliamp of current can be felt, 5 milliamps can cause severe pain, 15 milliamps can cause loss of muscle control, and 70 milliamps can be fatal. Wear protective clothing; ensure skin, clothing, and surrounding areas are dry; do not wear jewelry; and touch only the insulated, nonmetallic parts of electrical components and testing equipment. To prevent electrical arcing, avoid shorting electrical test probes and jumper wires. Electrical arcing can cause bright flashes of light, capable of causing temporary blindness. If electrical injury occurs, immediately shut off power supply and seek medical assistance. Failure to comply may result in serious injury or death to personnel.

HEATING VENTILATING AND AIR CONDITIONING (HVAC)/LIFE SUPPORT SYSTEM (LSS) MAIN BLOWER MOTOR WIRING HARNESS REMOVAL AND INSTALLATION - (CONTINUED)

REMOVAL

1. Twisting counterclockwise, remove HVAC/LSS main blower motor wiring harness connector (Figure 1, Item 2) from HVAC/LSS main blower motor (Figure 1, Item 1).

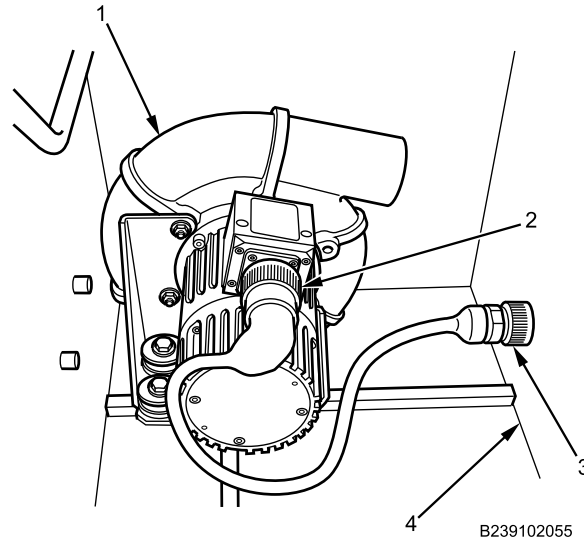

Figure 1. HVAC/LSS Main Blower Motor Wiring Harness.

2. Twisting counterclockwise, remove HVAC/LSS main blower motor wiring harness connector (Figure 1, Item 3) from HVAC/LSS box (Figure 1, Item 4).

END OF TASK

INSTALLATION

WARNING



Dielectric grease is harmful to skin and eyes. If grease contacts eyes, rinse thoroughly and contact physician if irritation persists. If skin is contacted, wash thoroughly with soap and water. Failure to comply may result in serious injury to personnel.

NOTE

Apply dielectric grease to all electrical connections.

1. Install HVAC/LSS main blower motor wiring harness connector (Figure 2, Item 2) on HVAC/LSS main blower motor (Figure 2, Item 1) by twisting clockwise until secure.

HEATING VENTILATING AND AIR CONDITIONING (HVAC)/LIFE SUPPORT SYSTEM (LSS) MAIN BLOWER MOTOR WIRING HARNESS REMOVAL AND INSTALLATION - (CONTINUED)

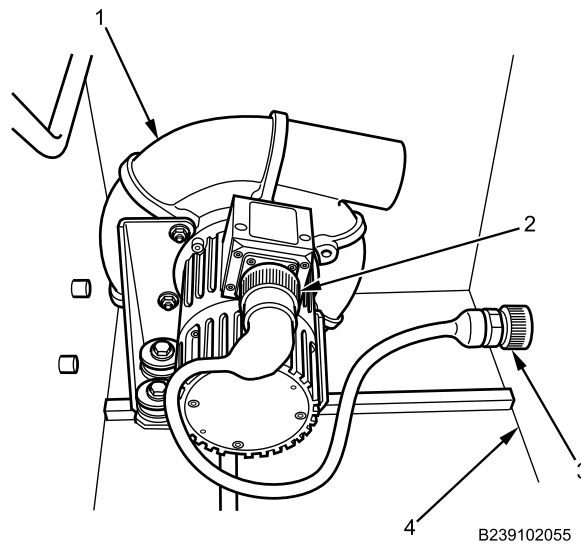

Figure 2. HVAC/LSS Main Blower Motor Wiring Harness.

2. Install HVAC/LSS main blower motor wiring harness connector (Figure 2, Item 3) on HVAC/LSS box (Figure 2, Item 4) by twisting clockwise until secure.

END OF TASK

FOLLOW-ON MAINTENANCE

1. Install NBC particle separator filter (WP 0764).
2. Install NBC filter cover and housing (WP 0763).
3. Install NBC filter (WP 0762).
4. Turn MAIN POWER switch on (TM 9-2355-106-10).
5. Start engine (TM 9-2355-106-10).
6. Close all doors and hatches securely (TM 9-2355-106-10).
7. Turn on HVAC/LSS to verify proper cabin pressure (TM 9-2355-106-10).
8. Turn off HVAC/LSS (TM 9-2355-106-10).
9. Turn engine off (TM 9-2355-106-10).
10. Install right side exterior body armor front panel (WP 0633).
11. Turn MAIN POWER switch off (TM 9-2355-106-10).
12. Remove wheel chocks (TM 9-2355-106-10).

END OF TASK

END OF WORK PACKAGE

FIELD MAINTENANCE**HEATING VENTILATING AND AIR CONDITIONING (HVAC)/LIFE SUPPORT SYSTEM (LSS) UPPER BLOWER
WIRING HARNESS REMOVAL AND INSTALLATION**

INITIAL SETUP:**Tools and Special Tools**

General Mechanic's Tool Kit (GMTK)
(WP 0795, Item 37)

WP 0782

Materials/Parts

Grease (WP 0794, Item 22)

Equipment Condition

Parking brake set (TM 9-2355-106-10)
Transmission set in NEUTRAL (N) (TM
9-2355-106-10)
Engine off (TM 9-2355-106-10)
Wheels chocked (TM 9-2355-106-10)
MAIN POWER switch off (TM 9-2355-106-10)
HVAC/LSS upper panel removed (WP 0767)

References

TM 9-2355-106-10
TM 9-2355-106-23P
WP 0786

WARNING

Use extreme caution when testing or working on or around electrical circuits. Always assume that electrical circuits are live. Electrical shock can occur upon contact with voltage high enough to cause current flow through muscles or nerves. On Direct Current (DC) systems, generally 1 milliamp of current can be felt, 5 milliamps can cause severe pain, 15 milliamps can cause loss of muscle control, and 70 milliamps can be fatal. Wear protective clothing; ensure skin, clothing, and surrounding areas are dry; do not wear jewelry; and touch only the insulated, nonmetallic parts of electrical components and testing equipment. To prevent electrical arcing, avoid shorting electrical test probes and jumper wires. Electrical arcing can cause bright flashes of light, capable of causing temporary blindness. If electrical injury occurs, immediately shut off power supply and seek medical assistance. Failure to comply may result in serious injury or death to personnel.

HEATING VENTILATING AND AIR CONDITIONING (HVAC)/LIFE SUPPORT SYSTEM (LSS) UPPER BLOWER WIRING HARNESS REMOVAL AND INSTALLATION - (CONTINUED)

REMOVAL

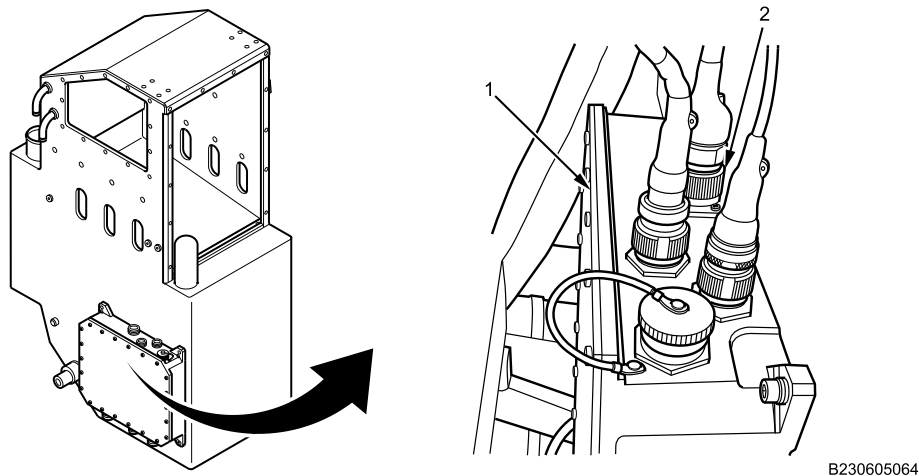

Figure 1. HVAC/LSS Upper Blower Wiring Harness at Climate Control Unit (CCU) Box.

1. Twisting counterclockwise, disconnect HVAC/LSS upper blower wiring harness connector (Figure 1, Item 2) from CCU box (Figure 1, Item 1).

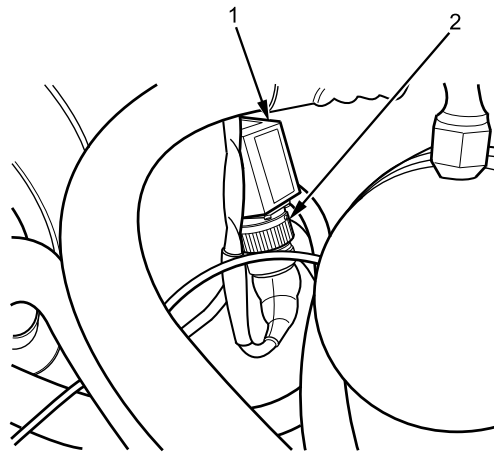
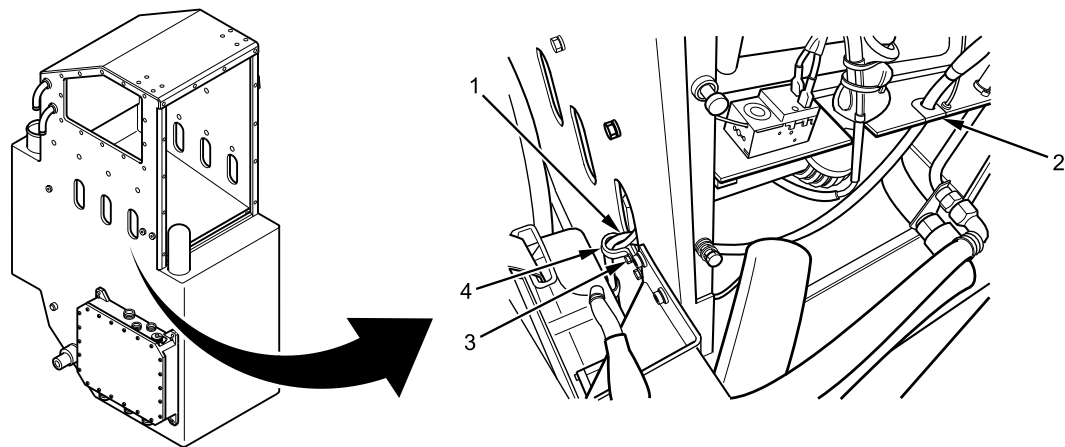

Figure 2. HVAC/LSS Upper Blower Wiring Harness at Upper HVAC/LSS Blower.

2. Twisting counterclockwise, disconnect HVAC/LSS upper blower wiring harness connector (Figure 2, Item 2) from HVAC/LSS upper blower (Figure 2, Item 1).

HEATING VENTILATING AND AIR CONDITIONING (HVAC)/LIFE SUPPORT SYSTEM (LSS) UPPER BLOWER WIRING HARNESS REMOVAL AND INSTALLATION - (CONTINUED)



B230605046

Figure 3. HVAC/LSS Upper Blower Wiring Harness Routing.

3. Remove bolt (Figure 3, Item 3) from insulated wire harness retainer (Figure 3, Item 4).
4. Remove insulated wire harness retainer (Figure 3, Item 4) from HVAC/LSS upper blower wiring harness (Figure 3, Item 1).
5. Remove HVAC/LSS upper blower wiring harness (Figure 3, Item 1) from wiring harness insulator (Figure 3, Item 2).

NOTE

HVAC/LSS upper blower wiring harness has different size connectors at each end. Harness must be removed as instructed in following step and must be aligned precisely to fit through HVAC box opening.

6. Remove wiring harness (Figure 3, Item 1) by pulling CCU box end of harness through opening in HVAC box.

END OF TASK

HEATING VENTILATING AND AIR CONDITIONING (HVAC)/LIFE SUPPORT SYSTEM (LSS) UPPER BLOWER WIRING HARNESS REMOVAL AND INSTALLATION - (CONTINUED)

INSTALLATION

WARNING



Dielectric grease is harmful to skin and eyes. If grease contacts eyes, rinse thoroughly and contact physician if irritation persists. If skin is contacted, wash thoroughly with soap and water. Failure to comply may result in serious injury to personnel.

NOTE

Apply dielectric grease to all electrical connections.

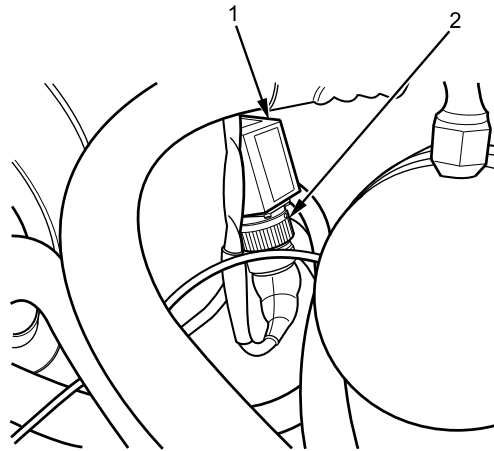

B239102066

Figure 4. HVAC/LSS Upper Blower Wiring Harness at Upper HVAC/LSS Blower.

1. Connect HVAC/LSS upper blower wiring harness connector (Figure 4, Item 2) on HVAC/LSS upper blower (Figure 4, Item 1) by twisting clockwise until secure.

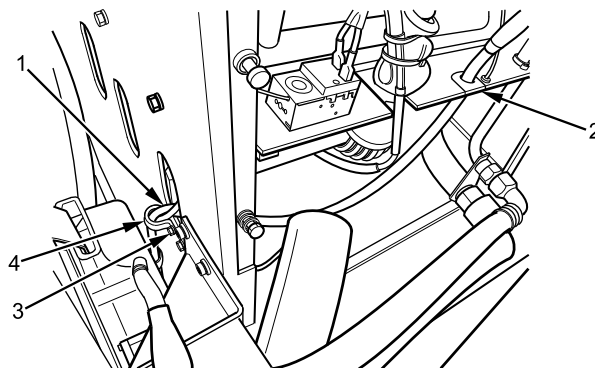

B239102067

Figure 5. HVAC/LSS Upper Blower Wiring Harness Routing.

HEATING VENTILATING AND AIR CONDITIONING (HVAC)/LIFE SUPPORT SYSTEM (LSS) UPPER BLOWER WIRING HARNESS REMOVAL AND INSTALLATION - (CONTINUED)

2. Install HVAC/LSS upper blower wiring harness (Figure 5, Item 1) on wiring harness insulator (Figure 5, Item 2).
3. Install insulated wiring harness retainer (Figure 5, Item 4) on HVAC/LSS upper blower wiring harness (Figure 5, Item 1) with bolt (Figure 5, Item 3). Tighten bolt securely.

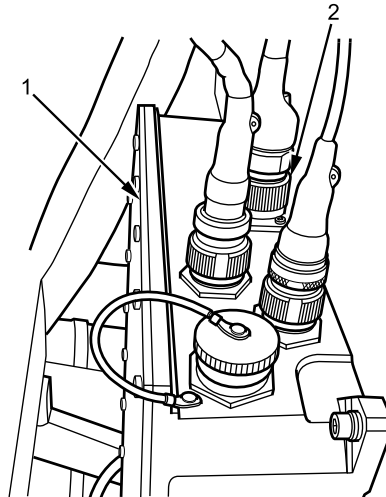

B239102065

Figure 6. HVAC/LSS Upper Blower Wiring Harness at CCU Box.

4. Connect HVAC/LSS upper blower wiring harness connector (Figure 6, Item 2) on CCU box (Figure 6, Item 1) by twisting clockwise until secure.

END OF TASK**FOLLOW-ON MAINTENANCE**

1. Install HVAC/LSS upper panel (WP 0767).
2. Turn MAIN POWER switch on (TM 9-2355-106-10).
3. Start engine (TM 9-2355-106-10).
4. Turn on HVAC/LSS to check for proper operation (TM 9-2355-106-10).
5. Turn off HVAC/LSS (TM 9-2355-106-10).
6. Turn engine off (TM 9-2355-106-10).
7. Turn MAIN POWER switch off (TM 9-2355-106-10).
8. Remove wheel chocks (TM 9-2355-106-10).

END OF TASK**END OF WORK PACKAGE**

FIELD MAINTENANCE
**HEATING VENTILATING AND AIR CONDITIONING (HVAC)/LIFE SUPPORT SYSTEM (LSS) CONTROL
WIRING HARNESS REMOVAL AND INSTALLATION**

INITIAL SETUP:**Tools and Special Tools**

General Mechanic's Tool Kit (GMTK)
(WP 0795, Item 37)

WP 0786

WP 0782

Materials/Parts

Cable lock strap - (2) (WP 0796, Item 134)
Grease (WP 0794, Item 22)
Wire tags (WP 0794, Item 33)

Equipment Condition

Parking brake set (TM 9-2355-106-10)
Transmission set in NEUTRAL (N) (TM
9-2355-106-10)
Engine off (TM 9-2355-106-10)
MAIN POWER switch off (TM 9-2355-106-10)
Wheels chocked (TM 9-2355-106-10)
HVAC/LSS upper panel removed (WP 0767)

References

TM 9-2355-106-10
TM 9-2355-106-23P

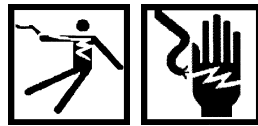
WARNING

Use extreme caution when testing or working on or around electrical circuits. Always assume that electrical circuits are live. Electrical shock can occur upon contact with voltage high enough to cause current flow through muscles or nerves. On Direct Current (DC) systems, generally 1 milliamp of current can be felt, 5 milliamps can cause severe pain, 15 milliamps can cause loss of muscle control, and 70 milliamps can be fatal. Wear protective clothing; ensure skin, clothing, and surrounding areas are dry; do not wear jewelry; and touch only the insulated, nonmetallic parts of electrical components and testing equipment. To prevent electrical arcing, avoid shorting electrical test probes and jumper wires. Electrical arcing can cause bright flashes of light, capable of causing temporary blindness. If electrical injury occurs, immediately shut off power supply and seek medical assistance. Failure to comply may result in serious injury or death to personnel.

Turn off ignition switch and battery disconnect switch before performing electrical system maintenance. Failure to comply may result in serious injury or death to personnel.

HEATING VENTILATING AND AIR CONDITIONING (HVAC)/LIFE SUPPORT SYSTEM (LSS) CONTROL WIRING HARNESS REMOVAL AND INSTALLATION - (CONTINUED)

REMOVAL

1. Twisting counterclockwise, disconnect HVAC/LSS control wiring harness connector (Figure 1, Item 2) from CCU box (Figure 1, Item 1).

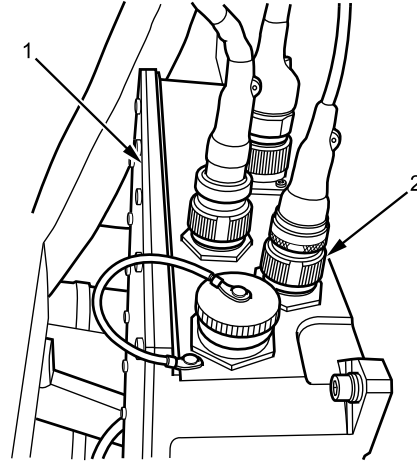

B239102070

Figure 1. HVAC/LSS Control Wiring Harness at Climate Control Unit (CCU) Box.

2. Remove bolt (Figure 2, Item 3) from insulated wiring harness retainer (Figure 2, Item 4).

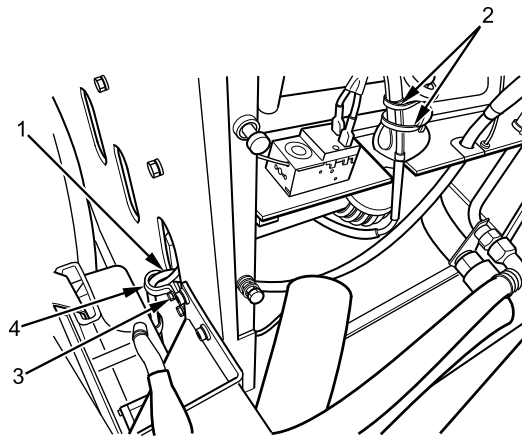

B239102071

Figure 2. HVAC/LSS Control Wiring Harness Mounting.

3. Remove insulated wiring harness retainer (Figure 2, Item 4) from HVAC/LSS control wiring harness (Figure 2, Item 1).
4. Cut two cable lock straps (Figure 2, Item 2) from HVAC/LSS control wiring harness (Figure 2, Item 1). Discard lock straps (Figure 2, Item 2).

HEATING VENTILATING AND AIR CONDITIONING (HVAC)/LIFE SUPPORT SYSTEM (LSS) CONTROL WIRING HARNESS REMOVAL AND INSTALLATION - (CONTINUED)

5. Twisting counterclockwise, disconnect HVAC/LSS control wiring harness connector (Figure 3, Item 1) from HVAC trinary pressure switch jumper harness (Figure 3, Item 2).

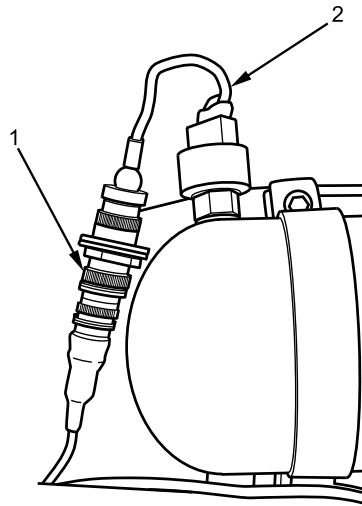

B239102072

Figure 3. HVAC Trinary Pressure Switch Connection.

6. Twisting counterclockwise, disconnect HVAC/LSS control wiring harness connector (Figure 4, Item 5) from Recirculated Air (RA) temperature sensor (Figure 4, Item 4).

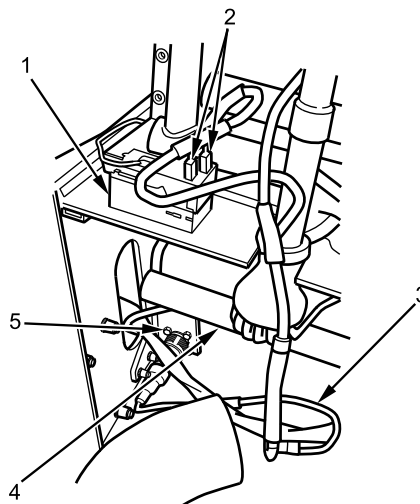

B239102073

Figure 4. HVAC/LSS Control Wiring Harness Routing.

NOTE

Mark and tag connectors on freeze switch to aid in installation.

7. Disconnect two connectors (Figure 4, Item 2) from freeze switch (Figure 4, Item 1).

HEATING VENTILATING AND AIR CONDITIONING (HVAC)/LIFE SUPPORT SYSTEM (LSS) CONTROL WIRING HARNESS REMOVAL AND INSTALLATION - (CONTINUED)

8. Remove HVAC/LSS control wiring harness (Figure 4, Item 3).

END OF TASK**INSTALLATION****WARNING**

Dielectric grease is harmful to skin and eyes. If grease contacts eyes, rinse thoroughly and contact physician if irritation persists. If skin is contacted, wash thoroughly with soap and water. Failure to comply may result in serious injury to personnel.

NOTE

Apply dielectric grease to all electrical connections.

1. Connect HVAC/LSS control wiring harness connector (Figure 5, Item 5) to RA temperature sensor (Figure 5, Item 4) by twisting clockwise until secure.

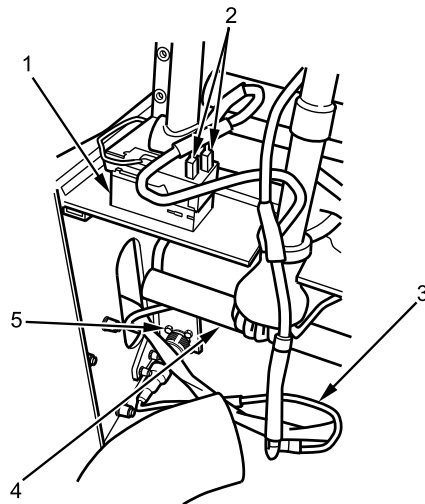

B239102073

Figure 5. HVAC/LSS Control Wiring Harness Routing.

2. Connect two connectors (Figure 5, Item 2) on freeze switch (Figure 5, Item 1) in locations noted during removal.

HEATING VENTILATING AND AIR CONDITIONING (HVAC)/LIFE SUPPORT SYSTEM (LSS) CONTROL WIRING HARNESS REMOVAL AND INSTALLATION - (CONTINUED)

3. Connect HVAC/LSS control wiring harness connector (Figure 6, Item 1) on HVAC trinary pressure switch jumper harness (Figure 6, Item 2) by twisting clockwise until secure.

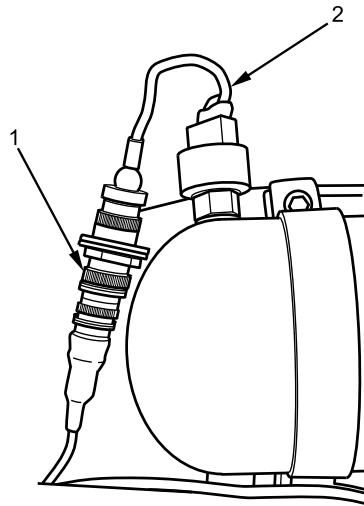

B239102072

Figure 6. HVAC Trinary Pressure Switch Connection.

4. Install HVAC/LSS control wiring harness (Figure 7, Item 1) on insulated wiring harness retainer (Figure 7, Item 4) with bolt (Figure 7, Item 3) and tighten securely.

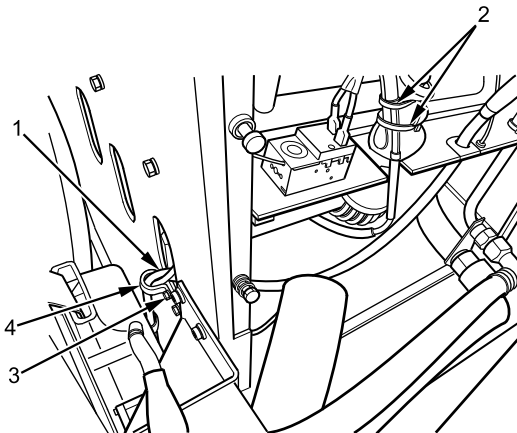

B239102071

Figure 7. HVAC/LSS Control Wiring Harness Mounting.

5. Install two new cable lock straps (Figure 7, Item 2) on HVAC/LSS control wiring harness (Figure 7, Item 1) and tighten securely.

HEATING VENTILATING AND AIR CONDITIONING (HVAC)/LIFE SUPPORT SYSTEM (LSS) CONTROL WIRING HARNESS REMOVAL AND INSTALLATION - (CONTINUED)

6. Connect HVAC/LSS control wiring harness connector (Figure 8, Item 2) on CCU box (Figure 8, Item 1) by twisting clockwise until secure.

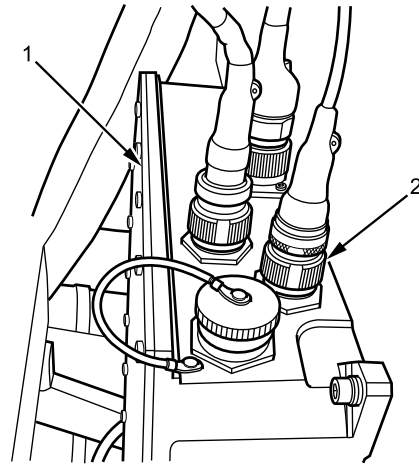

B239102070

Figure 8. HVAC/LSS Control Wiring Harness at CCU Box.

END OF TASK**FOLLOW-ON MAINTENANCE**

1. Install HVAC/LSS upper panel (WP 0767).
2. Turn MAIN POWER switch on (TM 9-2355-106-10).
3. Start engine (TM 9-2355-106-10).
4. Turn on HVAC/LSS to check for proper operation (TM 9-2355-106-10).
5. Turn off HVAC/LSS (TM 9-2355-106-10).
6. Turn engine off (TM 9-2355-106-10).
7. Turn MAIN POWER switch off (TM 9-2355-106-10).
8. Remove wheel chocks (TM 9-2355-106-10).

END OF TASK**END OF WORK PACKAGE**

FIELD MAINTENANCE
PREPARATION FOR STORAGE OR SHIPMENT

INITIAL SETUP:

NOT APPLICABLE

PREPARATION FOR SHIPMENT

No special preparation, other than maintenance, is required when MRAPs are driven under their own power to their destination.

All doors, except the driver door, should be tied closed. All material that exceeds the width of the vehicle should be removed and secured inside the vehicle. All antennas should be lowered and tied down.

Turn off all Government Furnished Equipment (GFE).

VEHICLE STORAGE

The unit is responsible for adequate storage and protection of new vehicles. Maintain records for vehicles in storage so that proper inspection and maintenance can be performed. Perform the following procedures before storing vehicle:

Storage Duration Two Months or Less**NOTE**

To avoid damaging the finish, avoid wiping dirt off of dry surfaces; wash vehicle when surface is cool to the touch.

1. Wash vehicle with warm water and mild soap. Dry wet surfaces with a chamois or soft cloth.
2. Inspect painted surfaces; touch up all exposed primed or raw metal areas to prevent rust.
3. Check radiator coolant reservoir for proper level and adequate freeze protection.
4. Cover open ends of exhaust and air intake for the HVAC system.

NOTE

A low electrolyte level is normally the result of a broken battery case or years of usage. It will not normally be seen on new vehicles.

5. Check batteries state of charge. Charge batteries if open circuit voltage is below 12.6 volts.
6. Fill fuel tank to maximum level. Ventilate system by releasing filler cap. If this can't be accomplished, completely drain the fuel tank.
7. Inspect vehicle prior to storage by performing the next appropriate PMCS, and make any repairs necessary. Ensure that maintenance services and lubrication are up to date.

PREPARATION FOR STORAGE OR SHIPMENT - (CONTINUED)**Storage Duration Over 2 Months**

Units in storage for longer than 2 months require the following additional procedures.

1. Inspect for the following:
 - a. Leaks
 - b. Low or flat tires
 - c. Corrosion
 - d. Water in compartments
 - e. Other problems or shortcomings
2. Perform the next scheduled major maintenance service.
3. Start and run vehicle at fast idle until it reaches operating temperature.
4. To remove surface charge from the battery, operate heater and air conditioner and turn on headlights and other accessories for a few minutes.
5. Drive the vehicle a short distance. Shift the transmission in various ranges; apply and release the service and parking brake systems.
6. Turn off heater and air conditioner and any other accessories; shut off lights. Park vehicle and shut off engine.
7. Disconnect and remove batteries and store in a cool, well-ventilated area. Recharge and clean before use.
8. Drain air brake reservoirs and close drain cocks.
9. Check radiator coolant reservoir for proper level and adequate freeze protection.
10. Lubricate all exposed components.

NOTE

After every 3 months of additional storage, repeat items 1 through 10.

11. For vehicles exposed to ultraviolet rays of the sun, apply a coating of powder cleanser, or similar product, to the inside surfaces of windshield and windows to shade the interior.

STORAGE FACILITIES

1. Whenever possible, store vehicles indoors, protected from sunlight, in a dry, well-ventilated area. If indoor storage is not available, select storage lots to eliminate conditions that cause deterioration.
2. Park away from transformers and/or electrical motors. When the protective wax in tire compound cracks, ozone in the air attacks the exposed areas.
3. Park away from trees, high weeds, and grass to prevent damage from tree or weed sap and to minimize bird and insect stains.
4. Park away from railroad tracks, paint shops, smoky industrial areas, and locations of possible road splash contact.
5. If a vehicle is parked on an incline, block the wheels.

END OF TASK**END OF WORK PACKAGE**

FIELD MAINTENANCE
GENERAL MAINTENANCE

INITIAL SETUP:**Tools and Special Tools**

General Mechanic's Tool Kit (GMTK)
(WP 0795, Item 37)
Jack stand (10-ton) (WP 0795, Item 62)

TM 9-2355-106-23P

TM 9-214

WP 0782

Materials/Parts

Goggles, industrial (WP 0794, Item 20)
Degreaser (WP 0794, Item 10)
Lubricating oil (WP 0794, Item 22)
Lubricating oil (WP 0794, Item 23)
Rag (WP 0794, Item 39)

Equipment Condition

Parking brake set (TM 9-2355-106-10)
Transmission set in NEUTRAL (N) (TM
9-2355-106-10)
Engine off (TM 9-2355-106-10)
MAIN POWER switch off (TM 9-2355-106-10)
Wheels chocked (TM 9-2355-106-10)

References

TM 9-2355-106-10

WARNING

Adhesives, solvents, and sealing compounds can burn easily, can give off harmful vapors, and are harmful to skin and clothing. Wear goggles and protective clothing. Keep away from open flame and use in well-ventilated area. If adhesive, solvent, or sealing compound get on skin or clothing, wash immediately with soap and water. Failure to comply may result in injury or death to personnel.

Before performing any maintenance procedure, ensure vehicle is parked on level surface, engine is off, parking brake is applied, transmission is in NEUTRAL (N), and wheels are chocked. Wear eye protection and stay clear of rotating parts and hot surfaces. Make sure all electrical tools are grounded. Use extreme caution when working under vehicle. Use hydraulic jack to raise vehicle, and place jackstands under frame rails to support axle. Keep first-aid and fire-control equipment available during all operation and maintenance procedures. Failure to comply may result in damage to equipment and serious injury or death to personnel.

Use extreme caution when testing or working on or around electrical circuits. Always assume that electrical circuits are live. Electrical shock can occur upon contact with voltage high enough to cause current flow through muscles or nerves. On Direct Current (DC) systems, generally 1 milliamp of current can be felt, 5 milliamps can cause severe pain, 15 milliamps can cause loss of muscle control, and 70 milliamps can be fatal. Wear protective clothing; ensure skin, clothing, and surrounding areas are dry; do not wear jewelry; and touch only the insulated, nonmetallic parts of electrical components and testing equipment. To prevent electrical arcing, avoid shorting electrical test probes and jumper wires. Electrical arcing can cause bright flashes of light, capable of causing temporary blindness. If electrical injury occurs, immediately shut off power supply and seek medical assistance. Failure to comply may result in serious injury or death to personnel.

GENERAL MAINTENANCE - (CONTINUED)**CLEANING****CAUTION**

Do not allow solvents to come in contact with seals, cables, or flexible hoses. These cleaners cause leather, rubber, and synthetic materials to dry out, rot, and lose pliability, making them unserviceable.

Cleaning procedures are the same for most parts and components of vehicle subassemblies.

1. GENERAL INSTRUCTIONS

- a. Perform all cleaning operations carefully and thoroughly. Dirt and foreign material can jeopardize vehicle operation and maintenance.
- b. Frequently wipe hands to remove grease, which can collect dust and grit.
- c. Clean all parts before inspection, after repair, and before assembly.
- d. After cleaning, cover all parts or wrap them in plastic or paper to protect them from dust and dirt.

2. DISASSEMBLED PARTS CLEANING

- a. Place all disassembled parts in wire baskets for cleaning.
- b. Dry and cover all cleaned parts.
- c. Place parts on or in racks to hold for inspection or repair.
- d. Lightly oil all parts subject to rusting.
- e. Wrap or cover parts if assembly procedures are not completed immediately.
- f. Keep all related parts and components together. Do not mix parts.

3. CASTINGS

- a. Clean inner and outer surfaces of castings with cleaning solvents.
- b. Use a stiff brush to remove sludge and gum deposits.

4. OIL PASSAGES

- a. Clean passages with wire probes to break up sludge or gum deposits.
- b. Give particular attention to all oil passages in castings and machined parts. Oil passages must be clean and free of any obstructions.
- c. Wash passages by flushing with solvents.

5. NONMETALLIC PARTS

Clean hoses and other nonmetallic parts with soap and water.

6. BEARINGS

Do not use compressed air to clean or dry bearings. Refer to TM 9-14, Inspection, Care, and Maintenance of Antifriction Bearings.

7. ELECTRICAL COMPONENTS

Clean electrical components with clean cloth dampened with cleaning solvent. Care must be taken not to damage protective insulation.

END OF TASK

GENERAL MAINTENANCE - (CONTINUED)**INSPECTION OF INSTALLED ITEMS**

Inspection procedures are the same for most parts and components of the vehicle subassemblies. General procedures are detailed in steps 1 through 10. Dimensional standards for parts have been fixed at extremely close tolerances. Use specified inspection equipment for inspection where cracks and other damage cannot be spotted visually. Exercise extreme care in all phases of inspection. All unserviceable components must be repaired or replaced.

1. CASTINGS

- a. Inspect all ferrous and nonferrous castings for cracks. Use penetrant methods for inspection. Particularly check areas around studs, pipe plugs, threaded inserts, and sharp corners. Replace cracked castings.
- b. Inspect machined surfaces for nicks, burrs, and raised metal. Mark damaged areas for repair or replacement.
- c. Inspect all pipe plugs, pipe plug openings, capscrews, and capscrew openings for damage and stripped threads. Replace if damaged or threads are stripped.
- d. Check all gasket mating surfaces, flanges on housings, and supports for warpage, using a straightedge or surface plate and feeler gauge. Inspect mating flanges for discolorations, which may indicate leakage. Replace if warped.
- e. Check all castings for cracks, nicks, burrs, and looseness.

2. BEARINGS

Check all bearings for cracks, nicks, burrs, wear, and looseness. Bearings found to have cracks, dents, discoloration, deformation, corrosion, or indications of spalling shall be replaced.

3. BUSHINGS AND BUSHING-TYPE BEARINGS

- a. Check all bushings and bushing-type bearings for secure fit and evidence of heating, wear, burrs, nicks, and out-of-round condition.
- b. Check for dirt in lubrication holes or grooves. Holes and grooves must be clean and free from damage.

4. MACHINED PARTS

- a. Check machined parts for cracks, distortion, and damage.
- b. Check all surfaces for nicks, burrs, and raised metal.

5. STUDS, BOLTS, CAPSCREWS, AND NUTS

Replace if bent, loose, or stretched, or if threads are damaged.

6. GEARS

- a. Inspect all gears for cracks and missing teeth. Replace if cracked or if teeth are missing.
- b. Inspect gear teeth for wear, sharp fins, burrs, and galled or pitted surfaces.
- c. Inspect splines for wear, burrs, and galled or pitted surfaces.
- d. Check keyway slots for wear and damage.

7. OIL SEALS

Oil seals are mandatory replacement items.

8. CASTING PLUGS

Inspect for leakage. Replace plugs when leakage is present.

9. SPRINGS

Inspect for damaged, distorted, and collapsed coils.

GENERAL MAINTENANCE - (CONTINUED)**10. SNAPRINGS, RETAINING RINGS, AND WASHERS**

Many of these parts are mandatory replacement items. Inspect all others for obvious damage and replace as necessary.

END OF TASK**REPAIR OR REPLACEMENT****CAUTION**

Repaired items must be thoroughly cleaned to prevent metal chips and abrasives from entering working parts of vehicle components.

Repair of most parts and components is limited to general procedures outlined in applicable maintenance instructions and the following detailed steps.

1. CASTINGS

- a. All cracked castings must be replaced.
- b. Only minor repairs are permitted for machined surfaces, flanges, and gasket mating surfaces. Remove minor nicks, burrs, and scratches by:
 - (1) Using fine-mill file.
 - (2) Using abrasive cloth dipped in cleaning solvent.
 - (3) Lapping across a surface plate.
- c. Refinishing of machined surfaces to repair damage, warpage, or uneven surfaces is not permitted. Replace castings that have these defects.
- d. Repair damaged threaded pipe plugs and/or capscrew holes with a thread tap, or repair oversize holes with threaded inserts.

2. BEARINGS

- a. Replace damaged or worn bearings.
- b. Coat bearings and contact surfaces with correct type of oil to ensure lubrication of parts during initial operation after repair.

3. STUDS

- a. Replace all bent and stretched studs.
- b. Repair minor thread damage with a thread restorer file. Replace studs having stripped or damaged threads as follows:
 - (1) Remove using a stud remover. Back studs out slowly to avoid heat buildup and seizure, which can cause stud to break off.
 - (2) If studs break off too short to use a stud remover, use extractor to remove.
 - (3) Replacement studs have a special coating and must have a small amount of antiseize compound applied on threads before stud is installed. Install replacement stud slowly to prevent heat buildup and snapping off.

4. GEARS

- a. Remove gears with pullers, as required.
- b. Use the repair methods described under Castings, step 1b, to remove minor nicks, burrs, or scratches on gear teeth.
- c. If keyways are worn or enlarged, replace gear.

GENERAL MAINTENANCE - (CONTINUED)**5. BUSHINGS AND BUSHING-TYPE BEARINGS**

When bushings and bushing-type bearings seize to a shaft and spin in the bore, the associated part must also be inspected and replaced as required.

6. OIL SEALS

- a. Oil seals are Mandatory Replacement Parts (MRPs).
- b. Remove oil seals, being careful not to damage casting or adapter bore.
- c. Always install new seal in bore, using proper seal-replacing tool.

END OF TASK**END OF WORK PACKAGE**

FIELD MAINTENANCE
LUBRICATION INSTRUCTIONS

INITIAL SETUP:

NOT APPLICABLE

GENERAL LUBRICATION INSTRUCTIONS

This work package includes all lubrication services to be performed on the M1224 and M1224A1 MRAP vehicles. Lubrication intervals are based on normal operation. Lubricate more often during constant use and less often during inactive periods. Use the correct grade of lubricant for climate and seasonal temperature expected.

LUBRICATION INSTRUCTIONS - (CONTINUED)

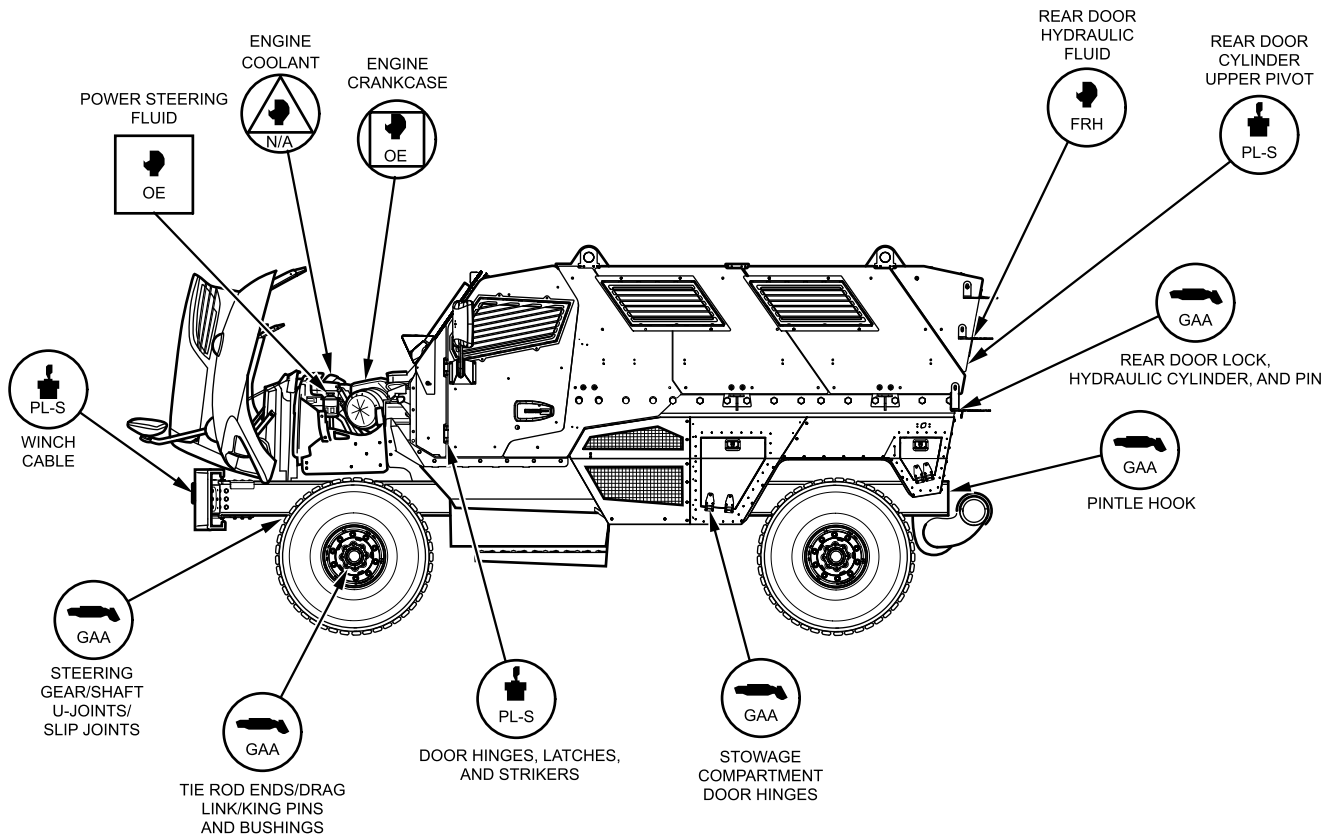

TABLE OF LUBRICANTS			SYMBOLS	FREQUENCY	METHOD OF APPLICATION
GAA	MIL-PRF-10924	GREASE, ARTILLERY, AND AUTOMOTIVE		1 YEAR OR 6,000 MILES	GREASE GUN
PL-S	MIL-PRF-32033	OIL		1 YEAR OR 10,000 MILES	BRUSH
FRH	MIL-PRF-46170	HYDRAULIC FLUID		1 YEAR OR 40,000 MILES	HAND
OE	MIL-PRF-2104	OIL		2 YEARS OR 72,000 MILES	
N/A	A-A-52624	COOLANT-ANTIFREEZE		2 YEARS OR 72,000 MILES	

B230605484

Figure 1. Body Overview.

LUBRICATION INSTRUCTIONS - (CONTINUED)

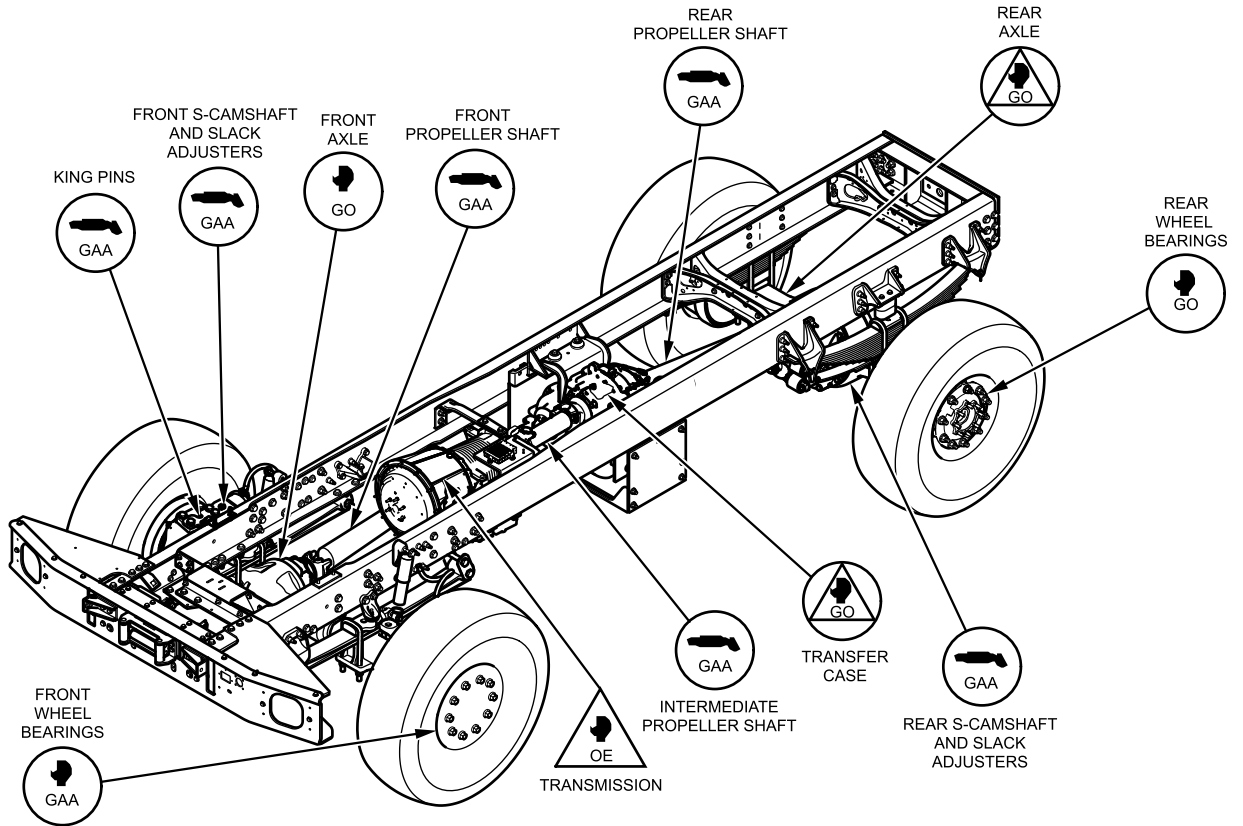
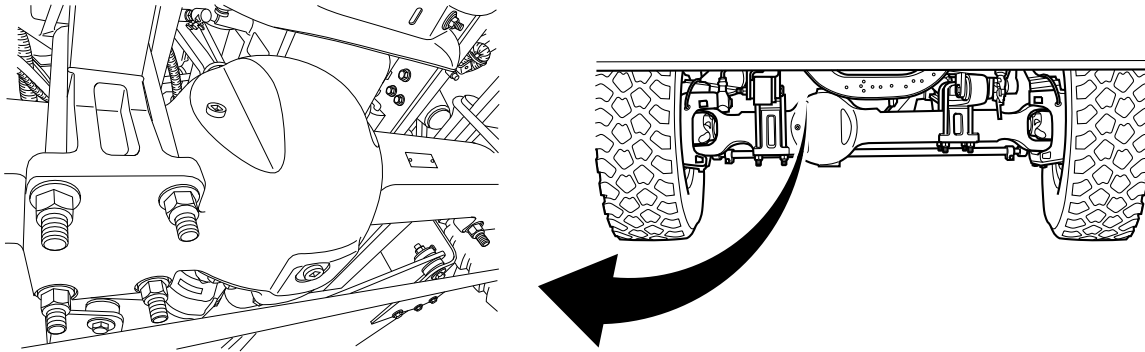

TABLE OF LUBRICANTS			SYMBOLS	FREQUENCY	METHOD OF APPLICATION
ID	SPECIFICATION	TYPE OF LUBRICANT			
GAA	MIL-PRF-10924	GREASE, ARTILLERY, AND AUTOMOTIVE		1 YEAR OR 10,000 MILES	GREASE GUN
OE	MIL-PRF-2104	OIL		2 YEARS OR 12,000 MILES	BRUSH
GO	SAE J2360	OIL		2 YEARS OR 50,000 MILES	HAND

B230605483

Figure 2. Chassis Overview.

LUBRICATION INSTRUCTIONS - (CONTINUED)



B230104666

Figure 3. Front Axle.

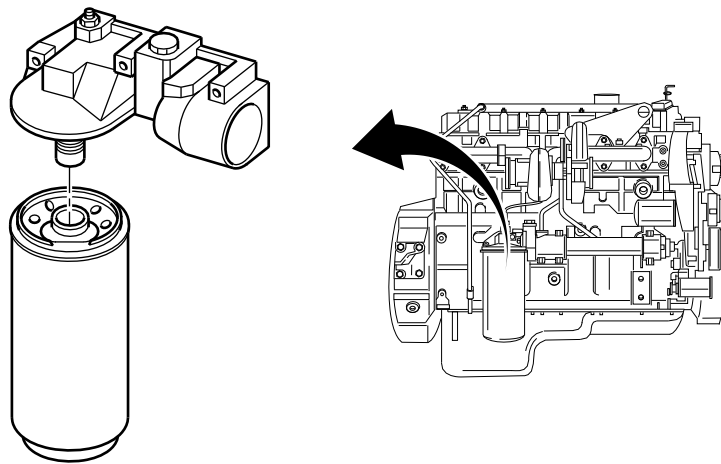

B100000199

Figure 4. Oil Filter.

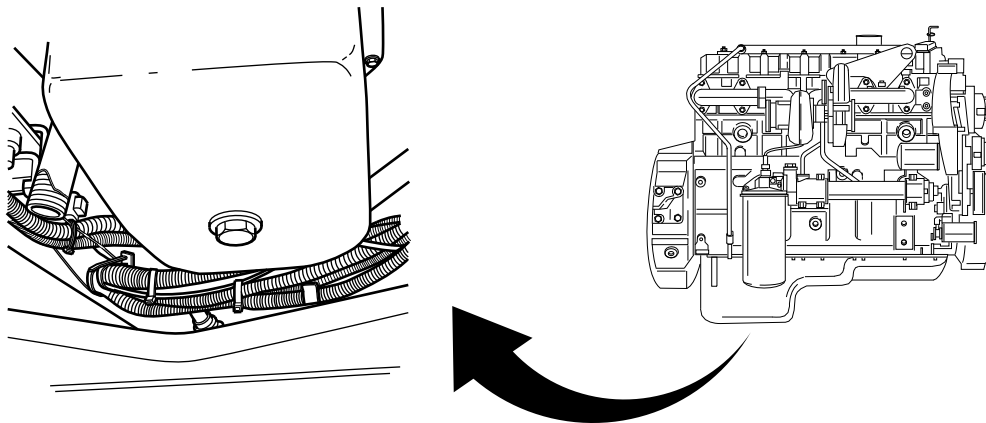

B230002971

Figure 5. Engine Oil Pan.

LUBRICATION INSTRUCTIONS - (CONTINUED)

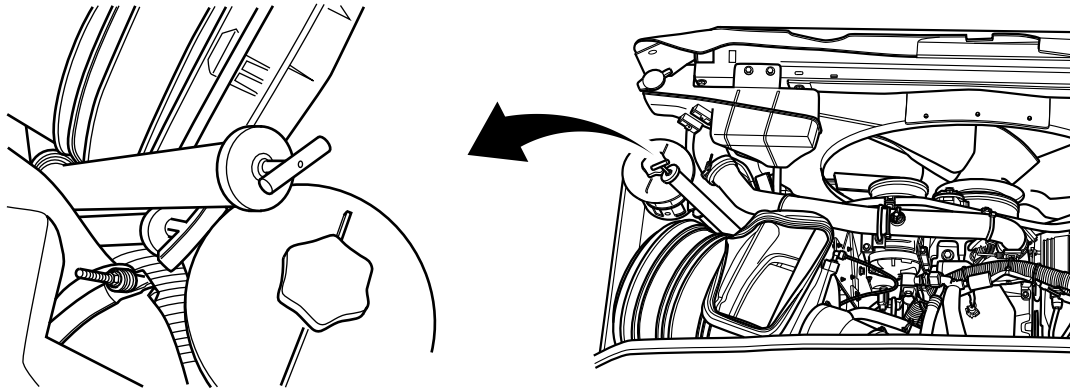

B230002972

Figure 6. Engine Oil Dipstick, Transmission Fluid Dipstick, and Power Steering Reservoir.

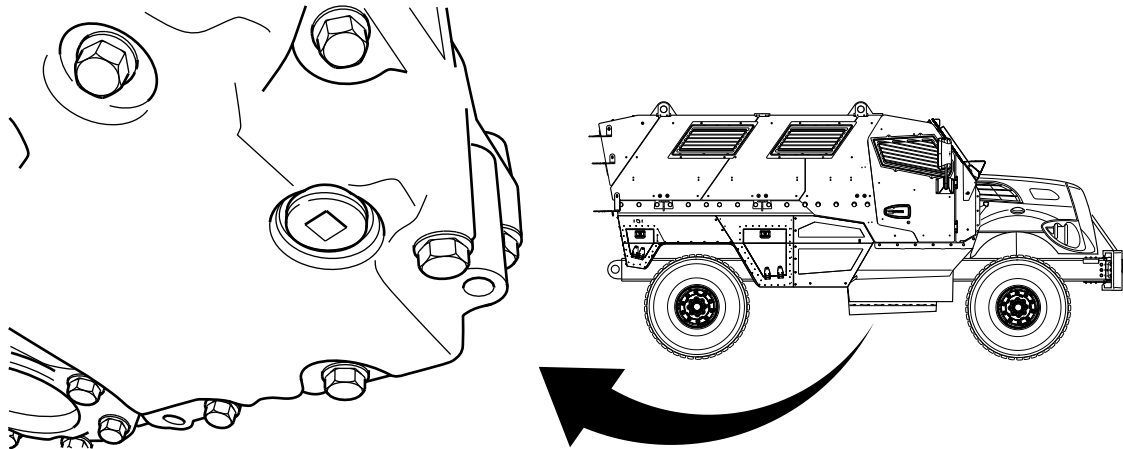

B230002973

Figure 7. Transmission Drain.

LUBRICATION INSTRUCTIONS - (CONTINUED)

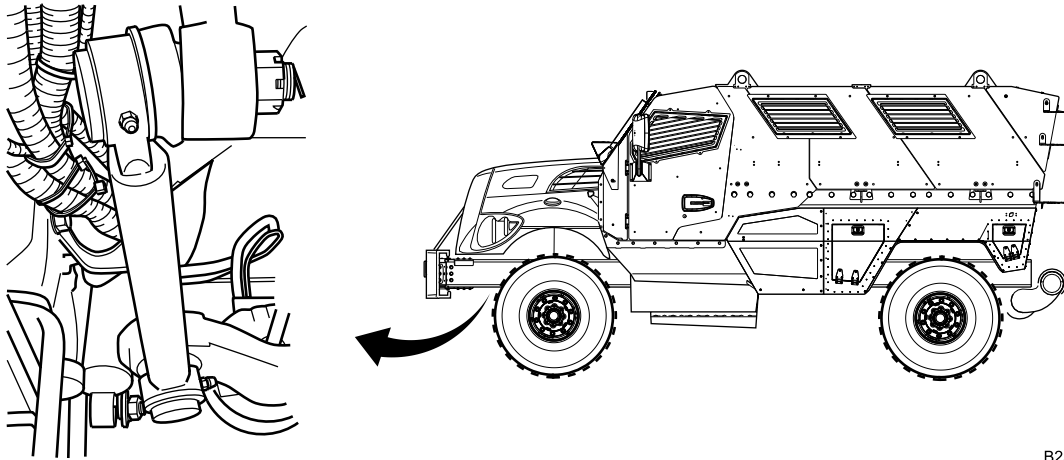

B230002974

Figure 8. Drag Link.

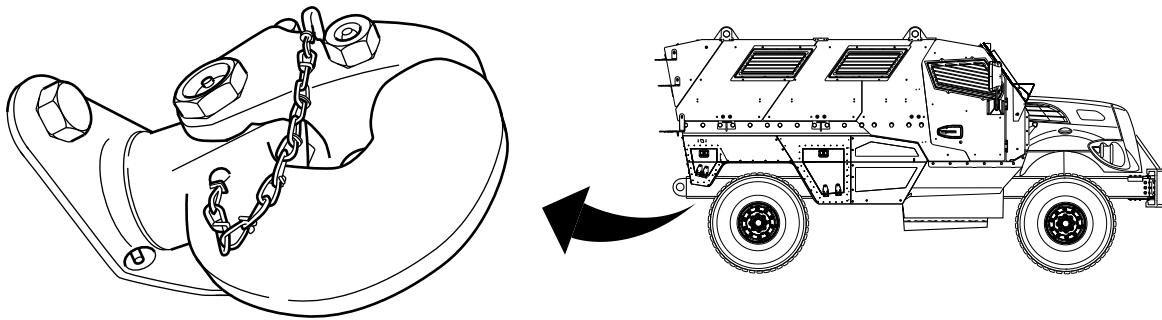

B230002975

Figure 9. Pintle Hook.

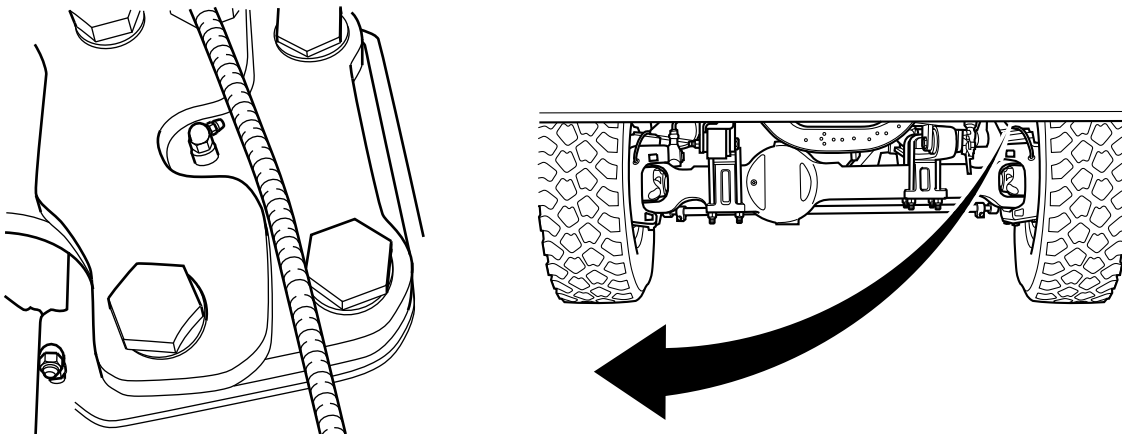

B230002976

Figure 10. Left Upper King Pin and Inner S-Camshaft (Right Similar).

LUBRICATION INSTRUCTIONS - (CONTINUED)

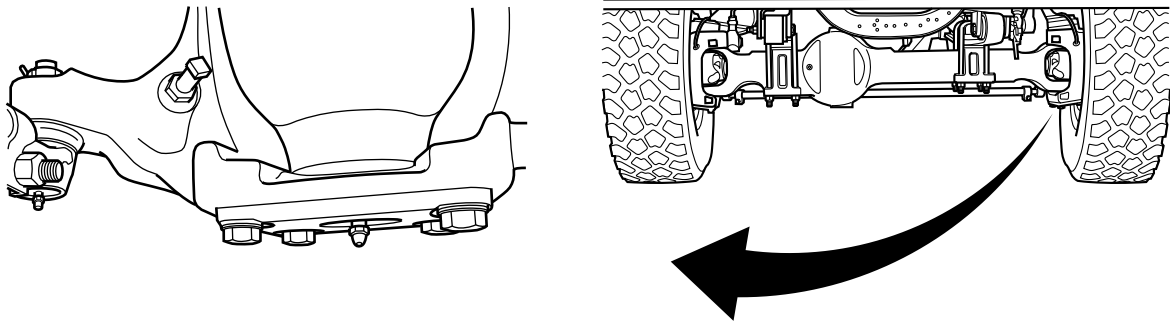

B230002977

Figure 11. Left Lower King Pin (Right Similar).

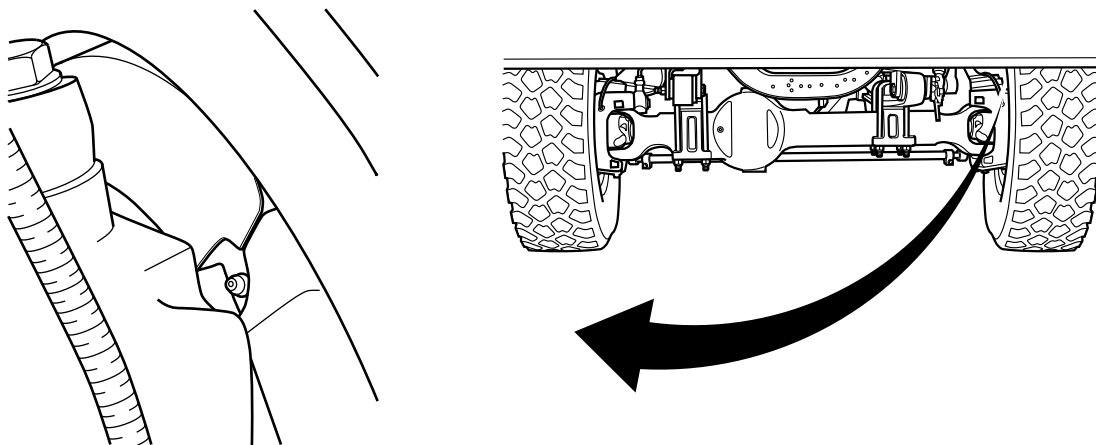

B230002978

Figure 12. Left Front Outer S-Camshaft (Right Similar).

LUBRICATION INSTRUCTIONS - (CONTINUED)

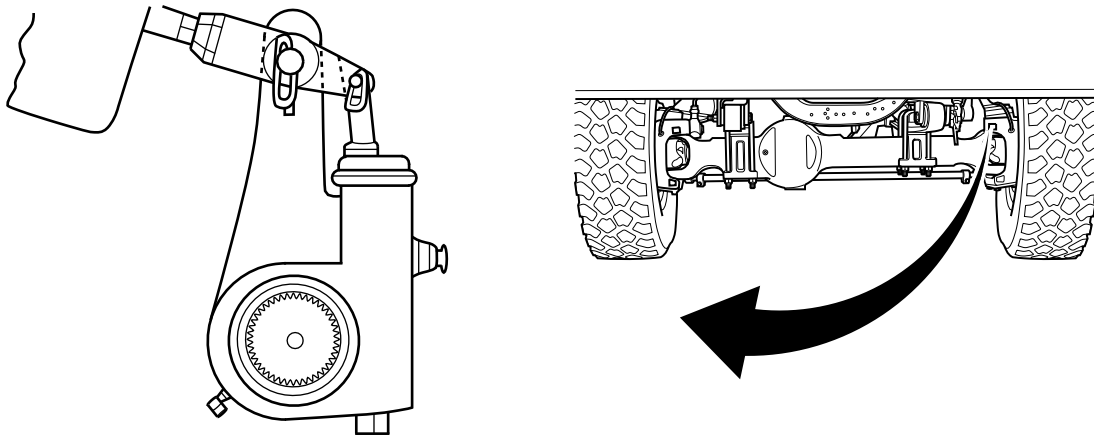

B230002979

Figure 13. Left Front Slack Adjuster (Right Similar).

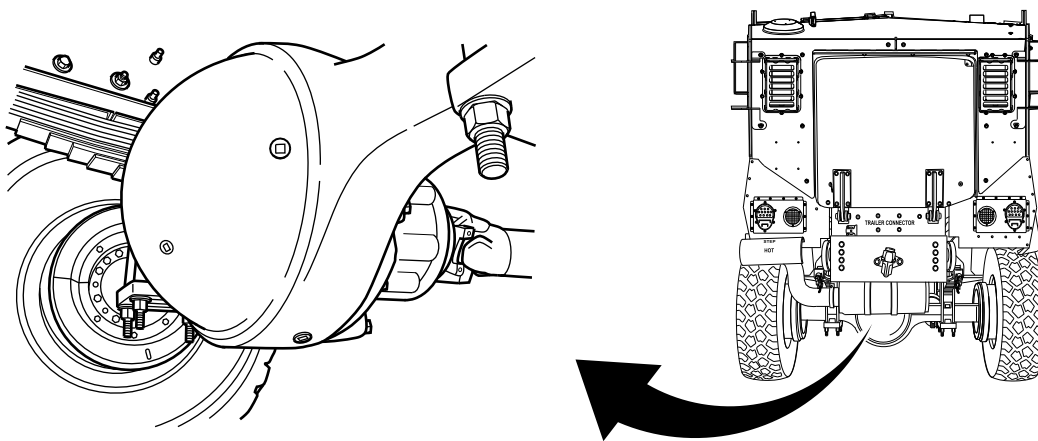

B230104667

Figure 14. Rear Axle.

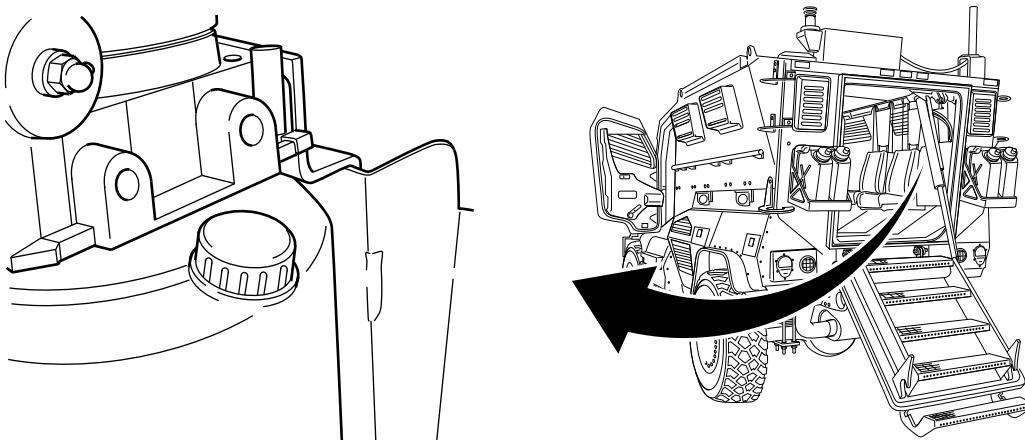

B230002980

Figure 15. Rear Door Hydraulic Fluid Reservoir.

LUBRICATION INSTRUCTIONS - (CONTINUED)

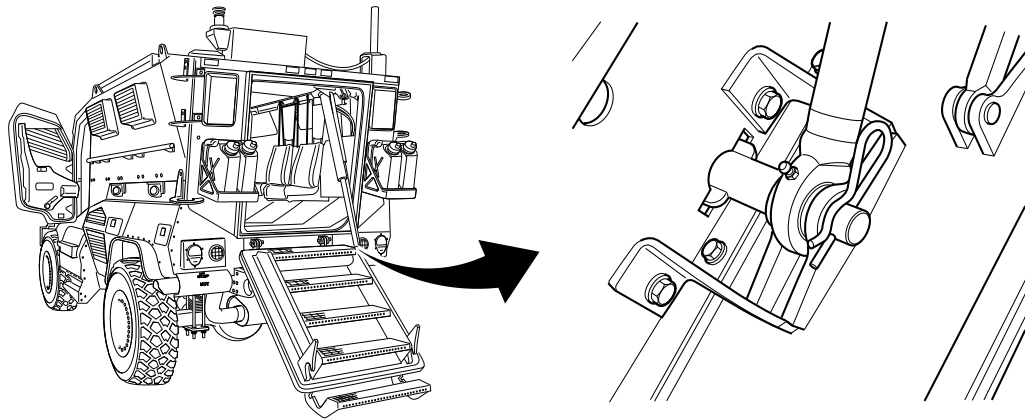

B230002981

Figure 16. Rear Door Hydraulic Cylinder at Door.

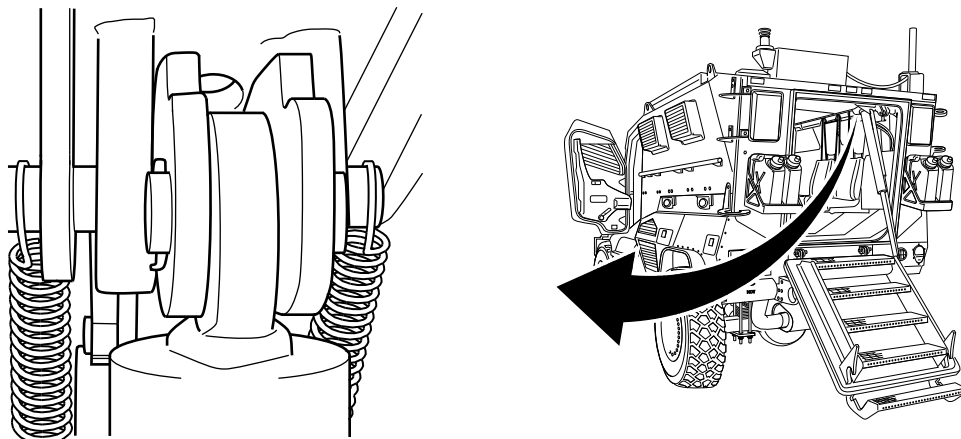

B230002982

Figure 17. Rear Door Hydraulic Cylinder Upper Pivot.

LUBRICATION INSTRUCTIONS - (CONTINUED)

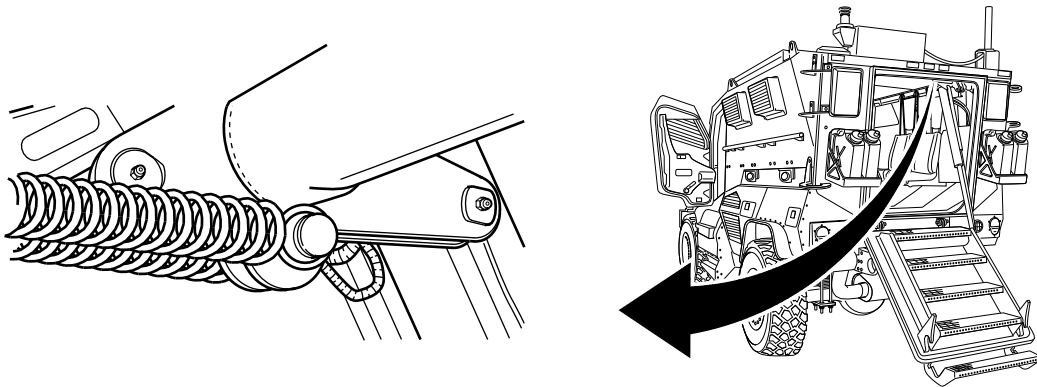

B230002983

Figure 18. Left Rear Door Lock (Right Similar).

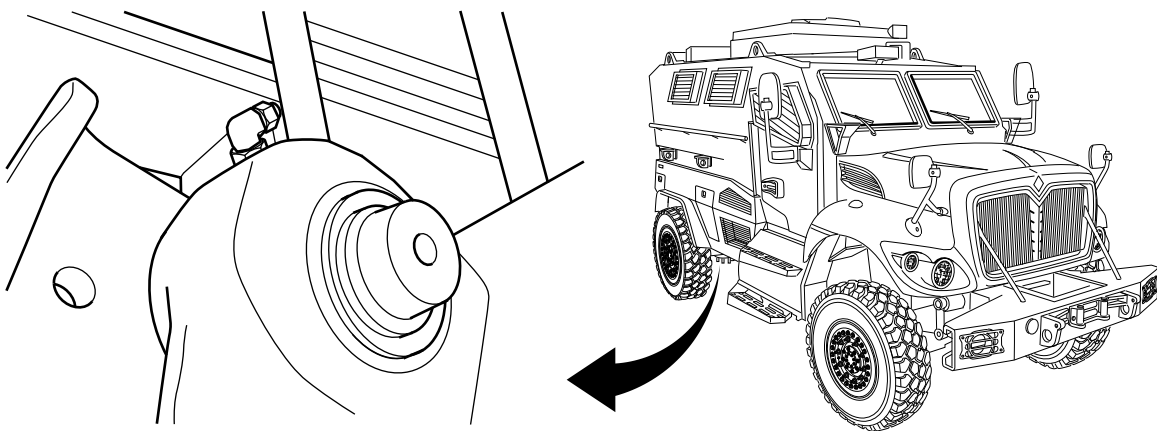

B230605482

Figure 19. Right Rear Slack Adjuster (Left Similar).

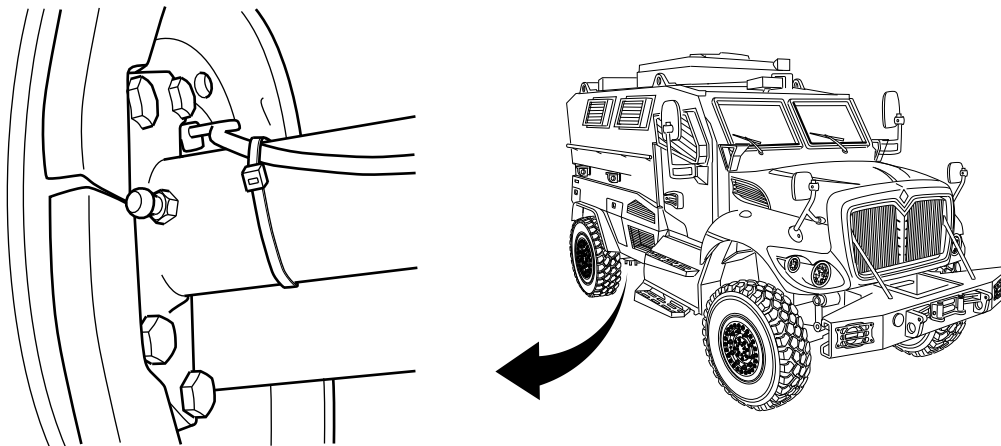

B230605481

Figure 20. Right Outer S-Camshaft (Left Similar).

LUBRICATION INSTRUCTIONS - (CONTINUED)

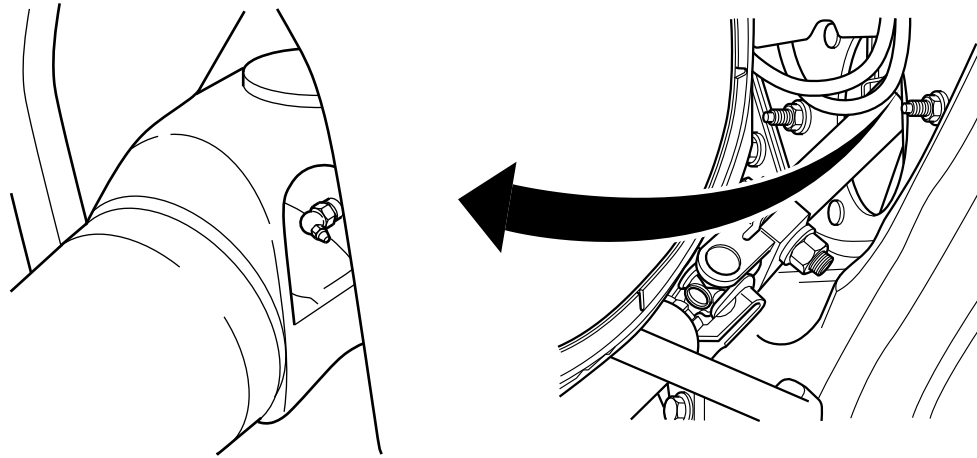

B230002986

Figure 21. Intermediate Steering Shaft, Upper.

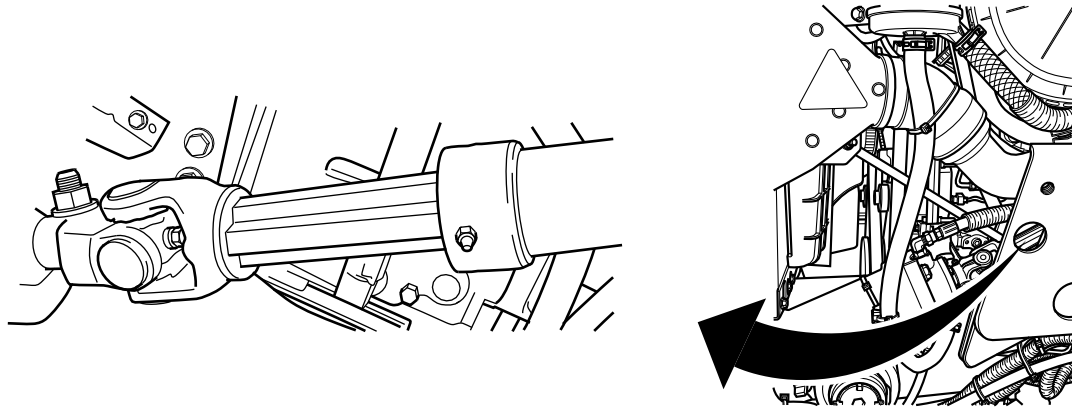

B230002987

Figure 22. Intermediate Steering Shaft, Lower.

LUBRICATION INSTRUCTIONS - (CONTINUED)

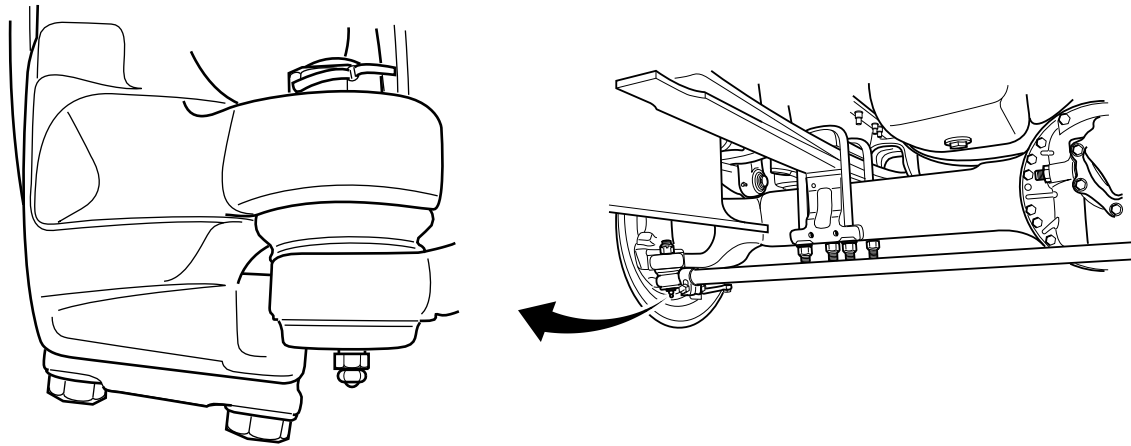

B230002988

Figure 23. Left Tie Rod End (Right Similar).

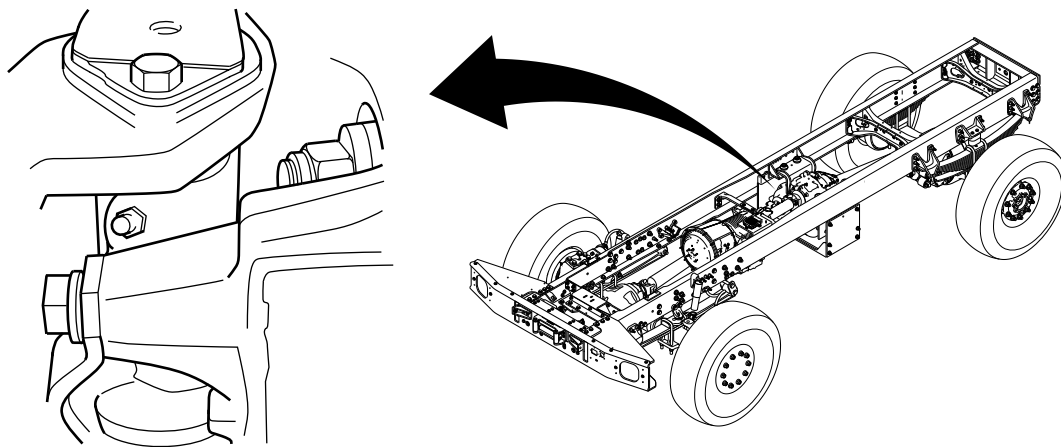

B230002989

Figure 24. Intermediate Propeller Shaft, Rear.

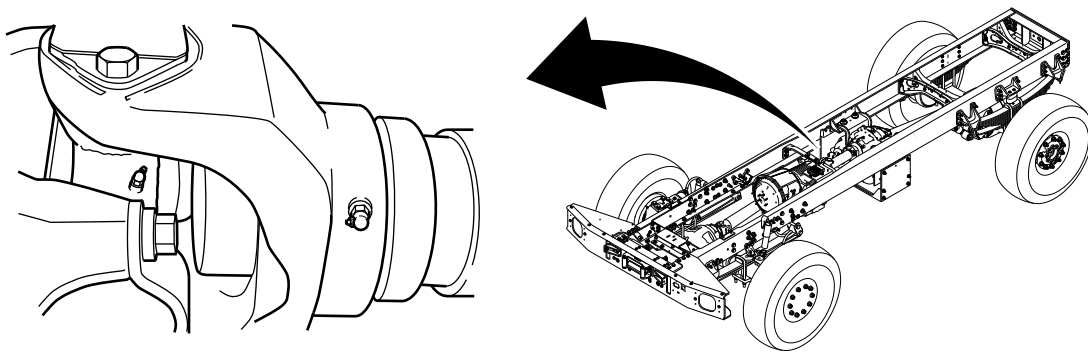

B230002990

Figure 25. Intermediate Propeller Shaft, Front.

LUBRICATION INSTRUCTIONS - (CONTINUED)

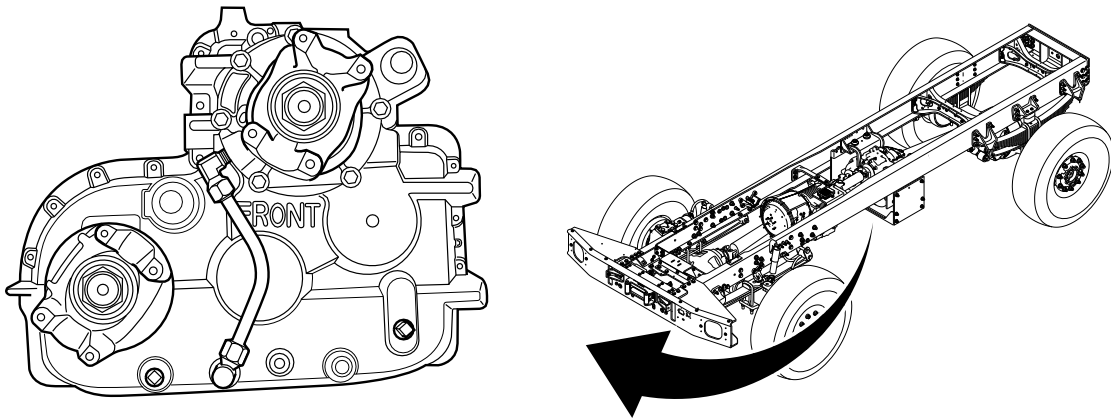

B230002996

Figure 26. Transfer Case.

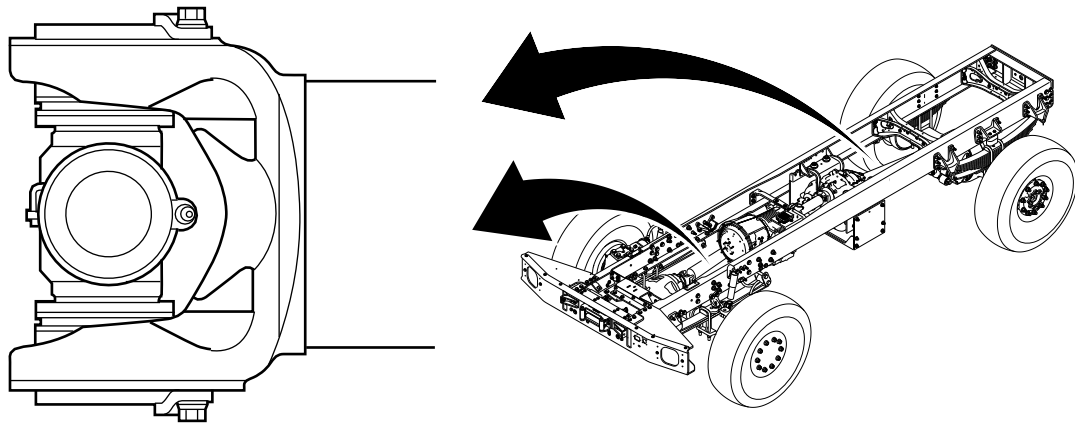

B230002991

Figure 27. Front and Rear Propeller Shafts — Two Universals Each.

LUBRICATION INSTRUCTIONS - (CONTINUED)

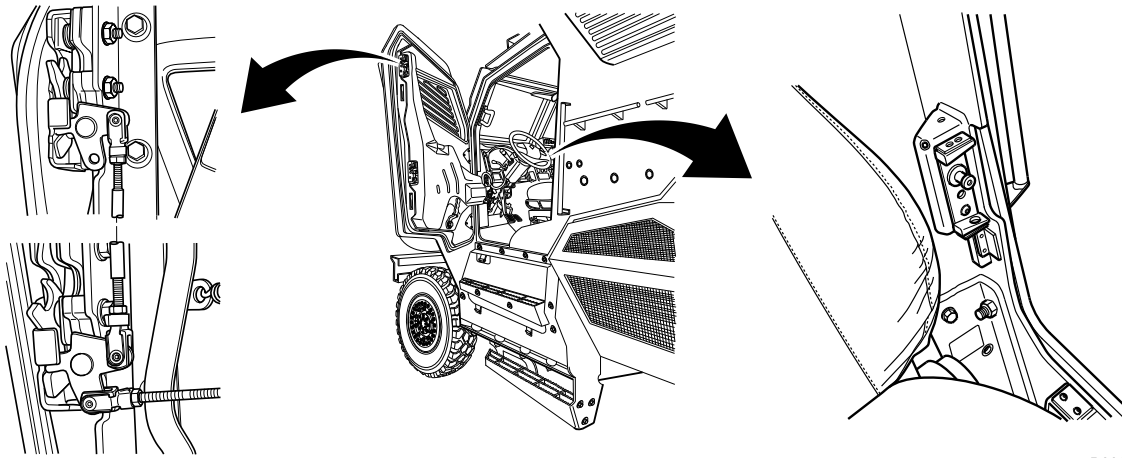

B230605486

Figure 28. Left Door Latches and Striker, Upper.

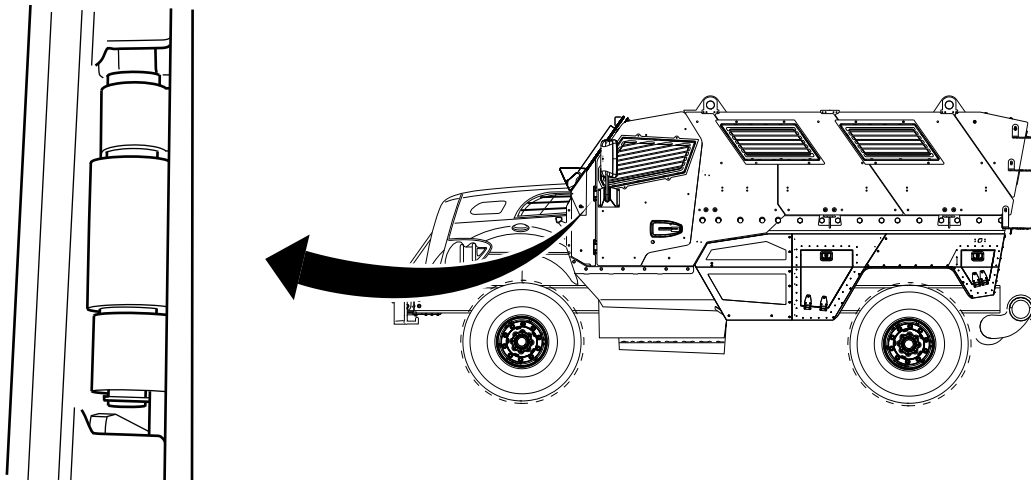

B230002992

Figure 29. Left Door Hinge, Upper.

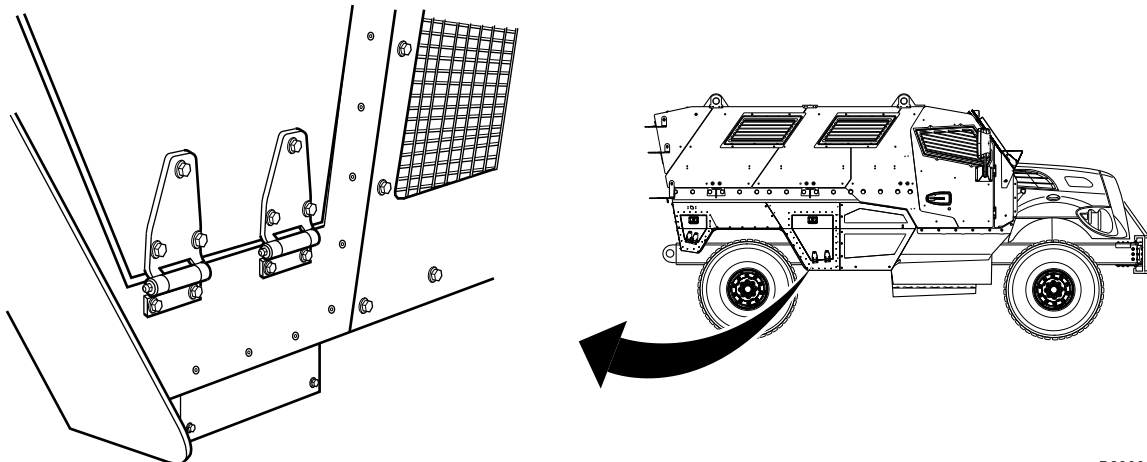

B230002993

Figure 30. Right Front Stowage Compartment (Left Similar).

LUBRICATION INSTRUCTIONS - (CONTINUED)

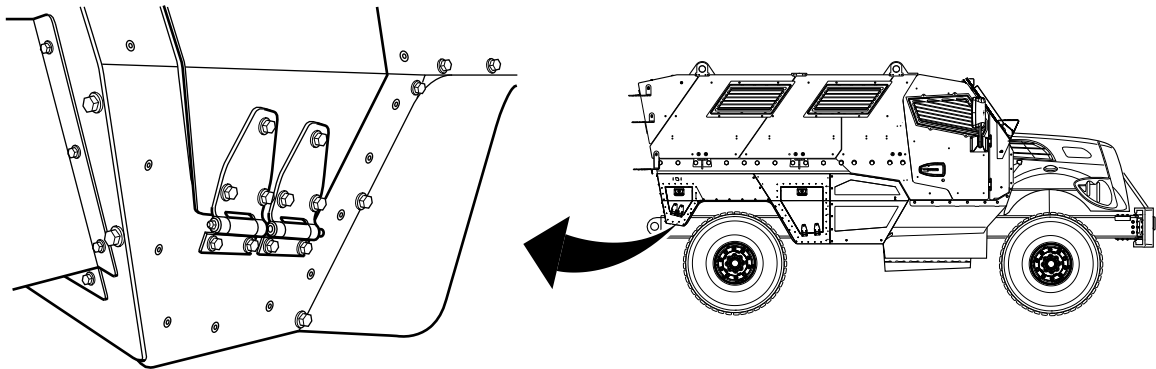

B230002994

Figure 31. Right Rear Stowage Compartment (Left Similar).

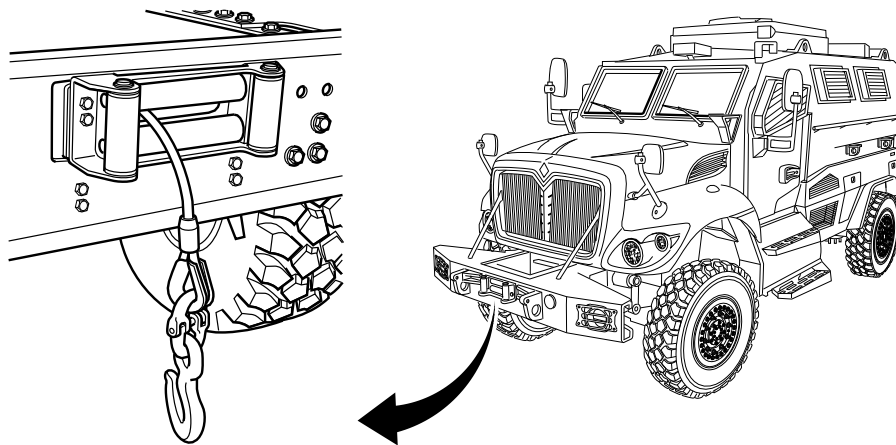

B102000490

Figure 32. Winch Cable.

LUBRICATION INSTRUCTIONS - (CONTINUED)

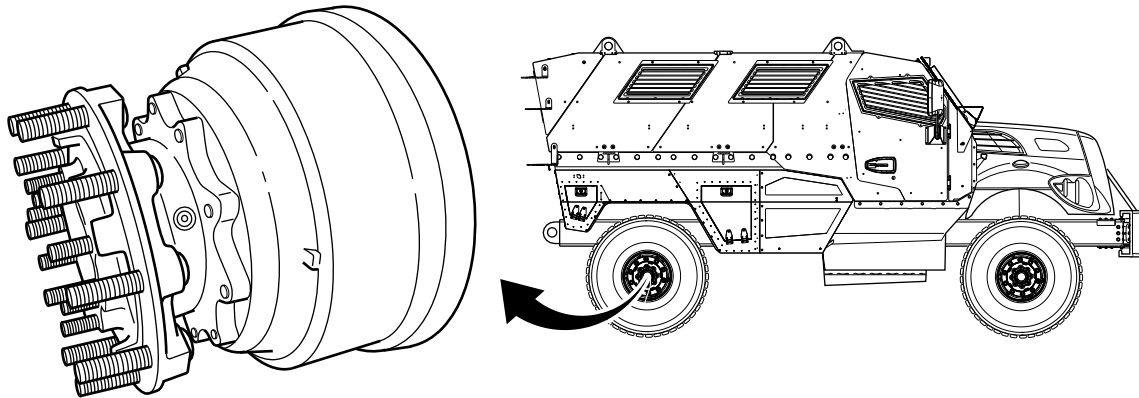

B230104665

Figure 33. Rear Wheel Bearings.

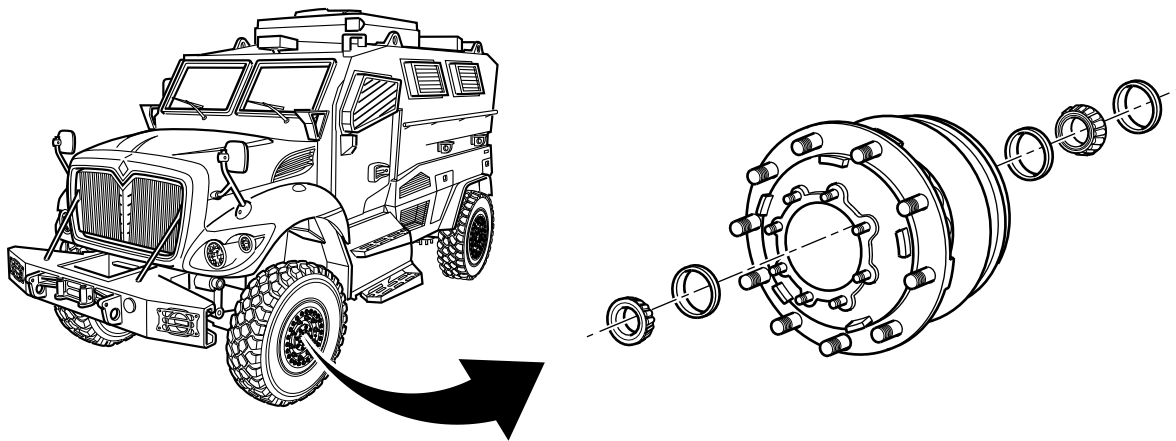

B230605485

Figure 34. Front Wheel Bearings.

LUBRICATION INSTRUCTIONS - (CONTINUED)

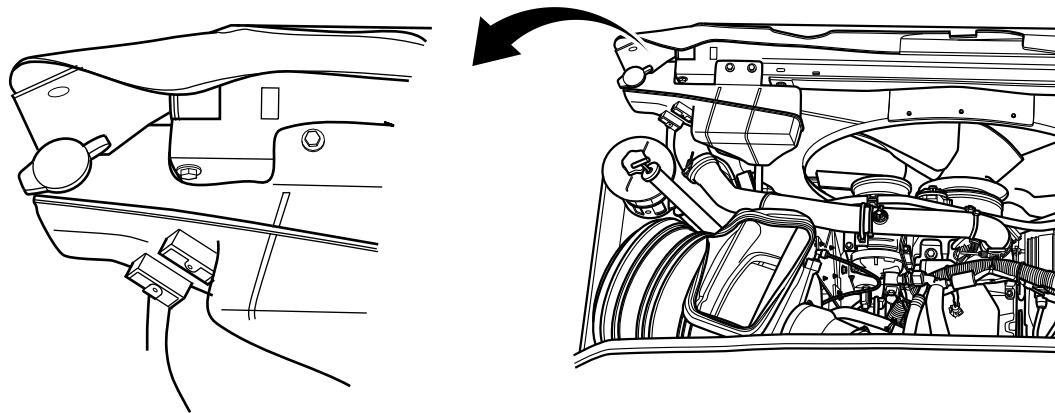

B100100488

Figure 35. Engine Coolant.

Table 1. Lubrication Schedule.

Refer to Figure 4, Figure 5, and Figure 6 for visual details.					
PART	CHANGE INTERVAL	CAPACITY	FLUID/LUBRICANT	TEMPERATURE RANGE	NATIONAL STOCK NUMBERS (NSN)
Engine Crankcase Oil (Refer to figures 1, 4, 5, 6)	1 yr or 6,000 miles	30 qt (28.3L)	MIL-PRF-2104 OE/HDO-15-40 SAE 15W-40 MIL-PRF-46167 OEA-30 (SAE 0W-30)	0°F to +120°F (-18°C to +49°C) < -50°F to +90°F (< -45°C to +32°C)	9150-01-178-4725 (1 qt)
					9150-01-421-1424 (5 gal)
					9150-01-421-1432 (55 gal)
					9150-00-402-4478 (1 qt)
					9150-00-402-2372 (5 gal)
					9150-00-491-7197 (55 gal)
Power Steering Fluid (Refer to Figure 1, 6)	1 yr or 40,000 miles	5.5 qt (5.2L)	MIL-PRF-2104 OE/HDO-15-40 (SAE 15W-40) OE/HDO-10 (SAE 10W) MIL-PRF-46167 OEA-30 (SAE 0W-30)	0°F to +120°F (-18°C to +49°C) < -15°F to +120°F (< -26°C to +49°C) < -50°F to +90°F (< -45°C to +32°C)	9150-01-178-4725 (1 qt bottle)
					9150-01-421-1424 (5 gal)
					9150-01-421-1432 (55 gal)
					9150-01-496-1957 (1 qt bottle)
					9150-00-186-6668 (5 gal)
					9150-00-191-2772 (55 gal)
					9150-00-402-4478 (1 qt)
					9150-00-402-2372 (5 gal)
9150-00-491-7197 (55 gal)					

LUBRICATION INSTRUCTIONS - (CONTINUED)

Refer to Figure 4, Figure 5, and Figure 6 for visual details.					
Steering Gear/ Shaft U-Joints/ Slip Joint (Refer to figures 1, 21, 22)	1 yr 10,000 miles	As required	MIL-PRF-10924 GAA	All temperatures	9150-01-197-7693 (14 oz) 9150-01-197-7690 (1.75 lb) 9150-01-197-7689 (6.5 lb) 9150-01-197-7692 (35 lb) 9150-01-197-7691 (120 lb) 9150-01-501-7745 (370 lb)
Front Wheel Bearing (Refer to figures 2, 34)	1 yr or 10,000 miles	As required	MIL-PRF-10924 GAA	All temperatures	9150-01-197-7693 (14 oz) 9150-01-197-7690 (1.75 lb) 9150-01-197-7689 (6.5 lb) 9150-01-197-7692 (35 lb) 9150-01-197-7691 (120 lb) 9150-01-501-7745 (370 lb)
Rear Wheel Bearing (Refer to figures 2, 33)	1 yr or 10,000 miles	1 qt (.95L)	SAE J2360 GO-85W/140 SAE 85W-140 SAE J2360 GO-75 (SAE 75)	10°F to 120°F (-12°C to +49°C) -40°F to +50°F (-40°C to +10°C)	9150-01-048-4591 (1 qt) 9150-01-035-5395 (5 gal) 9150-01-035-5396 (55 gal) 9150-01-035-5390 (1 qt) 9150-01-035-5391 (5 gal)
Tie Rod Ends/ Drag Link/King Pins and Bushings (Refer to figures 1, 8, 10, 11, 23)	1 yr or 10,000 miles	As required	MIL-PRF-10924 GAA	All temperatures	9150-01-197-7693 (14 oz) 9150-01-197-7690 (1.75 lb) 9150-01-197-7689 (6.5 lb) 9150-01-197-7692 (35 lb) 9150-01-197-7691 (120 lb) 9150-01-501-7745 (370 lb)
Rear Door Lock, Hydraulic Cylinder, Pin, Stowage Compartment Door Hinges, and Pintle Hook (Refer to figures 1, 9, 16, 18)	1 yr or 10,000 miles	As required	MIL-PRF-10924 GAA	All temperatures	9150-01-197-7693 (14 oz) 9150-01-197-7690 (1.75 lb) 9150-01-197-7689 (6.5 lb) 9150-01-197-7692 (35 lb) 9150-01-197-7691 (120 lb) 9150-01-501-7745 (370 lb)

LUBRICATION INSTRUCTIONS - (CONTINUED)

Refer to Figure 4, Figure 5, and Figure 6 for visual details.					
Front Axle (Refer to figures 2, 3)	1 yr or 10,000 miles	13 qt (12.3L)	SAE J2360 GO-85W/140 (SAE 85W-140) SAE J2360 GO-75 (SAE 75W)	10°F to 120°F (-12°C to +49°C) -40°F to +50°F (-40°C to +10°C)	9150-01-048-4591 (1 qt) 9150-01-035-5395 (5 gal) 9150-01-035-5396 (55 gal) 9150-01-035-5390 (1 qt) 9150-01-035-5391 (5 gal)
Rear Axle (Refer to figures 2, 14)	2 yrs or 50,000 miles	19.75 qt (18.7L)	SAE J2360 GO-85W/140 (SAE 85W-140) SAE J2360 GO-75 (SAE 75W)	10°F to 120°F (-12°C to +49°C) -40°F to +50°F (-40°C to +10°C)	9150-01-048-4591 (1 qt) 9150-01-035-5395 (5 gal) 9150-01-035-5396 (55 gal) 9150-01-035-5390 (1 qt) 9150-01-035-5391 (5 gal)
Transfer Case (Refer to figure 2. 26)	2 yrs or 50,000 miles	8 qt (7.57L)	SAE J2360 GO-80/90 (SAE 80W-90) SAE J2360 GO-75 (SAE 75W)	-10°F to 120°F (-23°C to +49°C) -40°F to +50°F (-40°C to +10°C)	9150-01-422-9329 (1 qt) 9150-01-422-9335 (5 gal) 9150-01-422-9340 (55 gal) 9150-01-035-5390 (1 qt) 9150-01-035-5391 (5 gal)
Propeller Shafts, U-Joints and Slip Joint (Refer to figures 2, 24, 25, 27)	1 yr or 10,000 miles	As required	MIL-PRF-10924 GAA	All temperatures	9150-01-197-7693 (14 oz) 9150-01-197-7690 (1.75 lb) 9150-01-197-7689 (6.5 lb) 9150-01-197-7692 (35 lb) 9150-01-197-7691 (120 lb) 9150-01-501-7745 (370 lb)
Transmission Fluid (Refer to figures 2, 6, 7)	2 yrs or 12,000 miles	29 qts (27.4 L) dry w/filter 19 qt (18 L) w/filter, drain and refill	MIL-PRF-2104 OE/HDO-15-40 (SAE 15W-40) MIL-PRF-46167 OEA-30 (SAE 0W-30)	-10°F to +120°F (-23°C to +49°C) < -50°F to +90°F (< -45°C to +32°C)	9150-01-178-4725 (1 qt bottle) 9150-01-421-1424 (5 gal) 9150-01-421-1432 (55 gal) 9150-00-402-4478 (1 qt) 9150-00-402-2372 (5 gal) 9150-00-491-7197 (55 gal)
Air Brakes – S-Cams-hafts and Slack Adjusters (Refer to figures 2, 10, 12, 13, 19, 20)	1 yr or 10,000 miles	As required	MIL-PRF-10924 GAA	All temperatures	9150-01-197-7693 (14 oz) 9150-01-197-7690 (1.75 lb) 9150-01-197-7689 (6.5 lb) 9150-01-197-7692 (35 lb) 9150-01-197-7691 (120 lb) 9150-01-501-7745 (370 lb)

LUBRICATION INSTRUCTIONS - (CONTINUED)

Refer to Figure 4, Figure 5, and Figure 6 for visual details.					
Door Hinges, Latches, Strikers, Seat Adjuster Slides, BII Storage Int/Ext, Rear Door Cylinder Upper Pivot, and Winch Cable (Refer to figures 1, 17, 18, 28, 29, 30, 31, 32)	1 yr or 10,000 miles	As required	MIL-PRF-32033 PL-S	-40°F to +120°F (-40°C to +49°C)	9150-00-836-8641 (1/2 oz) 9150-00-261-8146 (1 oz) 9150-00-273-2389 (4 oz) 9150-00-458-0075 (16 oz aerosol) 9150-01-374-2021 (16 oz sprayer) 9150-00-231-6689 (1 qt) 9150-00-231-9045 (1 gal) 9150-00-231-9062 (5 gal) 9150-00-281-2060 (55 gal)
Rear Door Hydraulic Fluid (Refer to figures 1, 15)	1 yr or 10,000 miles	6.5 qt (6.2 L)	MIL-PRF-46170 Type I	-40°F to +120°F (-40°C to +49°C)	9150-00-111-6256 (1 qt) 9150-00-111-6254 (1 gal) 9150-01-158-0462 (55 gal)
Coolant – Antifreeze (Refer to figures 1, 35)	2 yrs or 72,000 miles	29 qt (27.6 L)	A-A-52624 Type 1B (60% Ethylene Glycol Concentration) A-A-52624 Type 1C (50% Ethylene Glycol Concentration)	< -50°F to +120°F (< -45°C to +49°C) < -30°F to +120°F (< -34°C to +49°C)	6850-01-464-9266 (1 gal) 6850-01-464-9263 (5 gal) 6850-01-464-9096 (55 gal) 6850-01-471-6530 (1 gal) 6850-01-471-6534 (5 gal) 6850-01-471-6521 (55 gal)

END OF WORK PACKAGE

FIELD MAINTENANCE

ILLUSTRATED LIST OF MANUFACTURED ITEMS INTRODUCTION

ILLUSTRATED LIST OF MANUFACTURED ITEMS INTRODUCTION

Scope

This work package includes complete instructions for making items authorized to be manufactured or fabricated at the field maintenance level.

How To Use The Index Of Manufactured Items

A part number index in alphanumeric order is provided for cross-referencing the part number of the item to be manufactured to the information which covers fabrication criteria.

Explanation Of The Illustrations Of Manufactured Items

All instructions needed by maintenance personnel to manufacture the item are included on the illustrations. For additional information, refer to TM 9-2355-106-23P. All bulk materials needed for manufacture of an item are listed by part number or specification number in a tabular list on the illustration.

Table 2. Index of Manufactured Items.

PART NO./DRAWING NO.	NOMENCLATURE	FIGURE NO.
15210029168X375MM	Insulator, Hose, Rear Brake Hoses, Length 14.8 in. (375 mm)	Figure 8
15210029168X500MM	Insulator, Hose, Rear Brake Hoses, Length 19.7 in. (500 mm)	Figure 8
15210029168X541MM	Insulator, Hose, Fuel Fired Heater Fuel Pump and Supply Hoses, Length 21.3 in. (541 mm)	Figure 8
15210029168X1520MM	Insulator, Hose, Life Support System Interior Hoses, Length 59.8 in. (1520 mm)	Figure 4
1822646C1X7.75IN	Conduit, High Pressure Injection Pump Hose, Length 7.75 in. (196.9 mm)	Figure 29
2000310C1X1120MM	Conduit, Three-Way Valve and Exterior Coolant Hoses, Length 44.1 in. (1120 mm)	Figure 2
2000310C1X1130MM	Conduit, Three-Way Valve and Exterior Coolant Hoses, Length 44.5 in. (1130 mm)	Figure 2
2000310C1X1470MM	Conduit, Three-Way Valve and Exterior Coolant Hoses, Length 57.9 in. (1470 mm)	Figure 2
2000310C1X1757MM	Conduit, Three-Way Valve and Exterior Coolant Hoses, Length 69.2 in. (1757 mm)	Figure 2
2000310C1X2618MM	Conduit, Three-Way Valve and Exterior Coolant Hoses, Length 103.1 in. (2618 mm)	Figure 2
2605751C1X2388MM	Hose, Fuel Fired Heater Feed, Length 94 in. (2388mm)	Figure 9
2643669R1X300MM	Loom, Center Harness, Length 11.8 in. (300mm)	Figure 29
2644081R1X825MM	Conduit, DCM Brake Valves, 1.5 in. (38.1 mm) ID, Length 32.5 in. (825 mm)	Figure 21
2644094R1X	Conduit, Fan Drive, Length 11.5 in. (292 mm)	Figure 12
2644094R1X	Conduit, Fuel Fired Heater, Length 93.7 in. (2380 mm)	Figure 25
2644094R1X955MM	Conduit, Air Cleaner Assembly, Length 37.6 in. (955 mm)	Figure 7
2645001R1X620MM	Insulator, Hose, Transmission Oil Cooler, Length 24.4 in. (620 mm)	Figure 13
2645520R1X	Molding, Trim, Carrier Assembly, Driver Control, Length 9.1 in. (230 mm)	Figure 27
2645520R1X	Molding, Trim, Carrier Assembly, Driver Control, Length 6.7 in. (170 mm)	Figure 27
3113168C1LX22IN	Hose, Washer Supply, Windshield Wiper System, Length 22 in. (558.8 mm)	Figure 14
3113169C1LX90IN	Hose, Washer Supply, Windshield Wiper System, Length 90 in. (2286 mm)	Figure 14
3113865C1X16.5IN	Sleeve, Hose, Hydraulic Hoses, Length 16.5 in. (419.1 mm)	Figure 30

ILLUSTRATED LIST OF MANUFACTURED ITEMS INTRODUCTION - (CONTINUED)

PART NO./DRAWING NO.	NOMENCLATURE	FIGURE NO.
3577746C1X600MM	Insulator, Tubing, Gladhands, Length 23.6 in. (600 mm)	Figure 8
3577746C1X1400MM	Insulator, Tubing, Gladhands, Length 55.1 in. (1400 mm)	Figure 8
3692802C1X51MM	Insert, Wire Reinforced PVC, Front Frame Crossmember, Length 2 in. (51 mm)	Figure 27
3692802C1X152MM	Insert, Wire Reinforced PVC, Front Frame Crossmember, Length 6 in. (152 mm)	Figure 27
3692802C1X203MM	Insert, Wire Reinforced PVC, Flat Back Cowl Side Panel, Length 8 in. (203 mm)	Figure 27
3692802C1X457MM	Insert, Wire Reinforced PVC, Flat Back Cowl Side Panel, Length 18 in. (457 mm)	Figure 27
3693128C1X	Tape, Trim, Foam, Right and Left Inner Cabin Doors	Figure 23
3693128C1X2591MM	Tape, Trim, Foam, Underbody, Length 102 in. (2591 mm)	Figure 23
3693128C1X11430MM	Tape, Trim, Foam, Window Armor Glass, 37.5 ft (11.43 m)	Figure 23
375048C1X970MM	Loom, Conduit, Transfer Case Oil Cooler, Length 38.2 in. (970 mm)	Figure 28
375048C1X1770MM	Loom, Conduit, Transfer Case Oil Cooler, Length 69.7 in. (1770 mm)	Figure 28
375054C2X1070MM	Hose, Nonmetallic, Transfer Case Oil Cooler, Length 42.1 in. (1070 mm)	Figure 28
375054C2X1870MM	Hose, Nonmetallic, Transfer Case Oil Cooler, Length 73.6 in. (1870 mm)	Figure 28
375055C2X89.44IN	Tubing, Nonmetallic Air Dryer, Length 89.44 in. (2271.8 mm)	Figure 15
3820521C92	Hose Assembly, Transfer Case Oil Cooler Inlet	Figure 28
3821623C91	Hose Assembly, Transfer Case Oil Cooler Outlet	Figure 28
3823241C1X2050MM	Seal, Rubber, Flat Back Cowl, Length 80.7 in. (2050 mm)	Figure 22
3835432C1X	Seal, Rubber, Storage Boxes	Figure 26
3861924C1X114.2MM	Molding, Nonmetallic, Windshield Wiper System, Length 4.5 in. (114.2 mm)	Figure 27
417195C3X750MM	Tube, Black Nylon, Engine Cold Start Hosing, 1/8 in. (3.2 mm) OD, Length 29.5 in. (750 mm)	Figure 18
417196C3X12IN	Tube, Black Nylon, Fan and Fan Drive, 1/4 in. (6.4 mm) OD, Length 12 in. (304.8 mm)	Figure 11
417196C3X120IN	Tube, Black Nylon, Right and Left Door Actuator Assemblies, 1/4 in. (6.4 mm) OD, Length 120 in. (3048 mm)	Figure 18
417196C3X520MM	Tube, Black Nylon, Engine Exhaust Brake, 1/4 in. (6.4 mm) OD, Length 20.5 in. (520 mm)	Figure 18
417196C3X990MM	Tube, Black Nylon, Air Cleaner, 1/4 in. (6.4 mm) OD, Length 39 in. (990 mm)	Figure 6
417196C3X1050MM	Tube, Black Nylon, Rear Brakes Air Chamber, 1/4 in. (6.4 mm) OD, Length 41.3 in. (1050 mm)	Figure 18
417196C3X1200MM	Tube, Black Nylon, Transfer Case Air Lines, 1/4 in. (6.4 mm) OD, Length 47.2 in. (1200 mm)	Figure 18
417196C3X1250MM	Tube, Black Nylon, Transfer Case Air Lines, 1/4 in. (6.4 mm) OD, Length 49.2 in. (1250 mm)	Figure 18
417196C3X1380MM	Tube, Black Nylon, Air Cleaner, 1/4 in. (6.4 mm) OD, Length 54.3 in. (1380 mm)	Figure 6
417196C3X1500MM	Tube, Black Nylon, Transfer Case Air Lines, 1/4 in. (6.4 mm) OD, Length 59 in. (1500 mm)	Figure 18
417196C3X1800MM	Tube, Black Nylon, Transfer Case Air Lines, 1/4 in. (6.4 mm) OD, Length 70.9 in. (1800 mm)	Figure 18
417199C3X	Tube, Black Nylon, Hand Brake Control Valves and Lines, 3/8 in. (9.5 mm) OD	Figure 18
417199C3X	Tube, Black Nylon, Center Harness and Clips, 3/8 in. (9.5 mm) OD	Figure 18

ILLUSTRATED LIST OF MANUFACTURED ITEMS INTRODUCTION - (CONTINUED)

PART NO./DRAWING NO.	NOMENCLATURE	FIGURE NO.
417199C3X340MM	Tube, Black Nylon, Center Harness and Clips, 3/8 in. (9.5 mm) OD, Length 13.4 in. (340 mm)	Figure 18
417199C3X350MM	Tube, Black Nylon, Rear Brake Valves, 3/8 in. (9.5 mm) OD, Length 13.8 in. (350 mm)	Figure 18
417199C3X450MM	Tube, Black Nylon, Center Harness and Clips, 3/8 in. (9.5 mm) OD, Length 17.7 in. (450 mm)	Figure 18
417199C3X500MM	Tube, Black Nylon, Center Harness and Clips, 3/8 in. (9.5 mm) OD, Length 19.7 in. (500 mm)	Figure 18
417199C3X750MM	Tube, Black Nylon, Rear Brake Valves, 3/8 in. (9.5 mm) OD, Length 29.5 in. (750 mm)	Figure 18
417199C3X850MM	Tube, Black Nylon, Center Harness and Clips, 3/8 in. (9.5 mm) OD, Length 33.5 in. (850 mm)	Figure 18
417199C3X1100MM	Tube, Black Nylon, Rear Brake Valves, 3/8 in. (9.5 mm) OD, Length 43.3 in. (1100 mm)	Figure 18
417199C3X1450MM	Tube, Black Nylon, Gladhands, 3/8 in. (9.5 mm) OD, Length 57.1 in. (1450 mm)	Figure 18
417199C3X1830MM	Tube, Black Nylon, Center Harness and Clips, 3/8 in. (9.5 mm) OD, Length 72 in. (1830 mm)	Figure 18
417199C3X1960MM	Tube, Black Nylon, Center Harness and Clips, 3/8 in. (9.5 mm) OD, Length 77.2 in. (1960 mm)	Figure 18
417199C3X2000MM	Tube, Black Nylon, Air Dryer, 3/8 in. (9.5 mm) OD, Length 78.7 in. (2000 mm)	Figure 18
417199C3X2450MM	Tube, Black Nylon, Gladhands, 3/8 in. (9.5 mm) OD, Length 96.5 in. (2450 mm)	Figure 18
417199C3X3000MM	Tube, Black Nylon, Air Dryer, 3/8 in. (9.5 mm) OD, Length 118.1 in. (3000 mm)	Figure 18
417199C3X3100MM	Tube, Black Nylon, Gladhands, 3/8 in. (9.5 mm) OD, Length 122 in. (3100 mm)	Figure 18
417200C3X	Tube, Black Nylon, Hand Brake Control Valves and Lines, 1/2 in. (12.7 mm) OD	Figure 18
417200C3X300MM	Tube, Black Nylon, Front Brake Valves and Hoses, 1/2 in. (12.7 mm) OD, Length 11.8 in. (300 mm)	Figure 18
417200C3X400MM	Tube, Black Nylon, Front Brake Valves and Hoses, 1/2 in. (12.7 mm) OD, Length 15.7 in. (400 mm)	Figure 18
417200C3X800MM	Tube, Black Nylon, Front Brake Valves and Hoses, 1/2 in. (12.7 mm) OD, Length 31.5 in. (800 mm)	Figure 18
417200C3X1000MM	Tube, Black Nylon, Center Harness and Clips, 3/8 in. (9.5 mm) OD, Length 39.4 in. (1000 mm)	Figure 18
417200C3X1600MM	Tube, Black Nylon, Gladhands, 1/2 in. (12.7 mm) OD, Length 63 in. (1600 mm)	Figure 18
417200C3X2750MM	Tube, Black Nylon, Front Brake Valves and Hoses, 1/2 in. (12.7 mm) OD, Length 108.3 in. (2750 mm)	Figure 18
417201C3X	Tube, Black Nylon, Hand Brake Control Valves and Lines, 5/8 in. (15.9 mm) OD	Figure 18
417201C3X800MM	Tube, Black Nylon, Rear Brake Valves, 5/8 in. (15.9 mm) OD, Length 31.5 in. (800 mm)	Figure 18
417201C3X2300MM	Tube, Black Nylon, Air Dryer, 5/8 in. (15.9 mm) OD, Length 90.6 in. (2300 mm)	Figure 18
417202C3X1020MM	Tube, Black Nylon, Gladhands, 3/4 in. (19.1 mm) OD, Length 40.2 in. (1020 mm)	Figure 18
442498C1X1580MM	Conduit, Nylon, Left and Right Side Mirror Control Harnesses, Length 62.2 in. (1580 mm)	Figure 24

ILLUSTRATED LIST OF MANUFACTURED ITEMS INTRODUCTION - (CONTINUED)

PART NO./DRAWING NO.	NOMENCLATURE	FIGURE NO.
449632C1X1450MM	Conduit, Convolute, Gladhands, 1/2 in. (12.7 mm) ID, Length 57.1 in. (1450 mm)	Figure 29
449632C1X2450MM	Conduit, Convolute, Gladhands, 1/2 in. (12.7 mm) ID, Length 96.5 in. (2450 mm)	Figure 29
450017C1X711MM	Loom, Convolute, Power Steering Hoses, 1 in. (25.4 mm) ID, Length 28 in. (711 mm)	Figure 19
584067C1X774MM	Loom, Convolute, Power Steering Hoses, 1.25 in. (31.8 mm) ID, Length 30.5 in. (774 mm)	Figure 19
995509R2X914MM	Tube, Copper, Air Compressor Governor, 5/8 in. (15.9 mm) OD, Length 36 in. (914 mm)	Figure 16
L2643486X	Hose, Heater, Life Support System Interior Hoses, 3/4 in. (19 mm) ID	Figure 3
L2643486X95MM	Hose, Heater, Three-Way Valve and Exterior Coolant Hoses, 3/4 in. (19 mm) ID, Length 3.7 in. (95 mm)	Figure 1
L2643486X335MM	Hose, Heater, Three-Way Valve and Exterior Coolant Hoses, 3/4 in. (19 mm) ID, Length 13.2 in. (335 mm)	Figure 1
L2643486X660MM	Hose, Heater, Air Compressor Governor, 3/4 in. (19 mm) ID, Length 26 in. (660 mm)	Figure 5
L2643486X1180MM	Hose, Heater, Three-Way Valve and Exterior Coolant Hoses, 3/4 in. (19 mm) ID, Length 46.5 in. (1180 mm)	Figure 1
L2643486X1300MM	Hose, Heater, Three-Way Valve and Exterior Coolant Hoses, 3/4 in. (19 mm) ID, Length 51.2 in. (1300 mm)	Figure 1
L2643486X1580MM	Hose, Heater, Three-Way Valve and Exterior Coolant Hoses, 3/4 in. (19 mm) ID, Length 62.2 in. (1580 mm)	Figure 1
L2643486X1600MM	Hose, Heater, Life Support System Interior Hoses, 3/4 in. (19 mm) ID, Length 63 in. (1600 mm)	Figure 3
L2643486X1837MM	Hose, Heater, Three-Way Valve and Exterior Coolant Hoses, 3/4 in. (19 mm) ID, Length 72.3 in. (1837 mm)	Figure 1
L2643486X2678MM	Hose, Heater, Three-Way Valve and Exterior Coolant Hoses, 3/4 in. (19 mm) ID, Length 105.4 in. (2678 mm)	Figure 1
L2643493X343MM	Hose, Heater, Cooling Hose and Pipe, 1 in. (25.4 mm) ID, Length 13.5 in. (343 mm)	Figure 10
L2643504X300MM	Hose, Heater, Cooling Hose and Pipe, 3/8 in. (9.53 mm) ID, Length 11.8 in. (300 mm)	Figure 10
L2643504X675MM	Hose, Heater, Cooling Hose and Pipe, 3/8 in. (9.53 mm) ID, Length 26.6 in. (675 mm)	Figure 10
L2643504X1435MM	Hose, Heater, Cooling Hose and Pipe, 3/8 in. (9.53 mm) ID, Length 56.5 in. (1435 mm)	Figure 10
L2643505X9.5IN	Hose, Coolant, Air Compressor, 1/2 in. (12.7 mm) ID, Length 9.5 in. (241.3 mm)	Figure 5
L2643505X13IN	Hose, Coolant, Air Compressor, 1/2 in. (12.7 mm) ID, Length 13 in. (330.2 mm)	Figure 5
L2643544X450MM	Hose, Nonmetallic, Fuel Tank Breather, 5/16 in. (7.9 mm) ID, Length 17.7 in. (450 mm)	Figure 17
L2643545X900MM	Hose, Heavy Duty, Front Axle, 3/8 in. (9.5 mm) ID, Length 35.4 in. (900 mm)	Figure 17
L2643546X	Hose, Nonmetallic, Rear Axle, 1/2 in. (12.7 mm) ID	Figure 17
L2643546X975MM	Hose, Nonmetallic, Transfer Case, 1/2 in. (12.7 mm) ID, Length 38.5 in. (975 mm)	Figure 17
L2643623X915MM	Hose, Fuel and Oil, Power Steering Hose, 1 in. (25.4 mm) ID, Length 36 in. (915 mm)	Figure 20

END OF WORK PACKAGE

FIELD MAINTENANCE
ILLUSTRATED LIST OF MANUFACTURED ITEMS

INITIAL SETUP:**Tools and Special Tools**

General Mechanic's Tool Kit (GMTK)
(WP 0795, Item 37)

References

TM 9-2355-106-23P

HEATING, VENTILATING AND AIR CONDITIONING (HVAC) HEATER HOSES AND CONDUIT**NOTE**

Most HVAC heater hoses are constructed of heater hose covered with reflective conduit. The following two HVAC heater hoses are not covered with reflective conduit:

Tee-to-cabin floor pass-through, part number L2643486X335MM

3-way valve inlet-to-elbow, part number L2643486X95MM

Table 1 lists bulk materials from which items are manufactured.

Table 2 lists hose and conduit lengths required to make the HVAC hose assemblies.

Table 3 lists conduit and hose part numbers used together to assemble the HVAC hose assemblies.

1. Cut lengths of bulk hose (Figure 1, Item 1) to dimensions specified in Table 2.

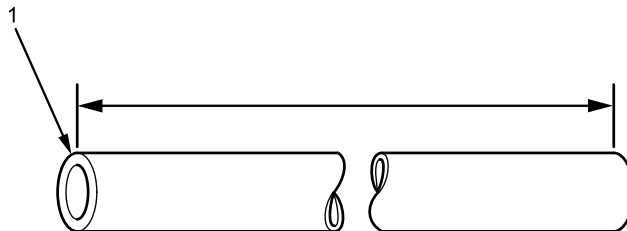

B230002908

Figure 1. Hose.

ILLUSTRATED LIST OF MANUFACTURED ITEMS - (CONTINUED)

2. Cut lengths of bulk conduit (Figure 2, Item 1) to dimensions specified in Table 2.

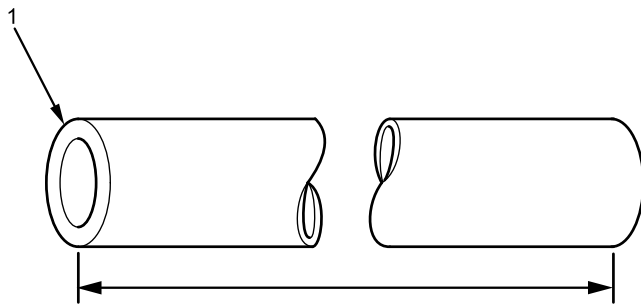

B230002907

Figure 2. Conduit.

Table 1. Material.

DESCRIPTION	PART NUMBER	CAGEC	NSN	QUANTITY
Hose, Heater, 3/4 in. (19 mm) ID x 50 ft (15.24 m)	L2643486	338X5	4720-01-269-4725	As required
Conduit, Hose, 1-1/8 in. (28.6 mm) ID	2000310C1	338X5	4730-01-513-4407	As required

Table 2. Hose and Conduit Lengths.

PART NUMBER	DESCRIPTION	CUT LENGTH	MANUFACTURED FROM NSN
2000310C1X1120MM	Conduit, Hose, 1-1/8 in. ID	44.1 in. (1120 mm)	4730-01-513-4407
2000310C1X1130MM	Conduit, Hose, 1-1/8 in. ID	44.5 in. (1130 mm)	4730-01-513-4407
2000310C1X1470MM	Conduit, Hose, 1-1/8 in. ID	57.9 in. (1470 mm)	4730-01-513-4407
2000310C1X1757MM	Conduit, Hose, 1-1/8 in. ID	69.2 in. (1757 mm)	4730-01-513-4407
2000310C1X2618MM	Conduit, Hose, 1-1/8 in. ID	103.1 in. (2618 mm)	4730-01-513-4407
L2643486X95MM	Hose, Heater, 3/4 in. ID	3.7 in. (95 mm)	4720-01-269-4725
L2643486X335MM	Hose, Heater, 3/4 in. ID	13.2 in. (335 mm)	4720-01-269-4725
L2643486X1180MM	Hose, Heater, 3/4 in. ID	46.5 in. (1180 mm)	4720-01-269-4725
L2643486X1300MM	Hose, Heater, 3/4 in. ID	51.2 in. (1300 mm)	4720-01-269-4725
L2643486X1580MM	Hose, Heater, 3/4 in. ID	62.2 in. (1580 mm)	4720-01-269-4725
L2643486X1837MM	Hose, Heater, 3/4 in. ID	72.3 in. (1837 mm)	4720-01-269-4725
L2643486X2678MM	Hose, Heater, 3/4 in. ID	105.4 in. (2678 mm)	4720-01-269-4725

ILLUSTRATED LIST OF MANUFACTURED ITEMS - (CONTINUED)

Table 3. HVAC Hose Assemblies.

HOSE PART NUMBER	CONDUIT PART NUMBER
L2643486X1180MM	2000310C1X1120MM
L2643486X1300MM	2000310C1X1130MM
L2643486X1580MM	2000310C1X1470MM
L2643486X1837MM	2000310C1X1757MM
L2643486X2678MM	2000310C1X2618MM

LIFE SUPPORT SYSTEM (LSS) HOSES AND HOSE INSULATORS

NOTE

The two hoses inside the LSS box are not covered with insulation.

Table 4 lists bulk materials from which items are manufactured.

1. Cut length of bulk hose (Figure 3, Item 1), part number L2643486, at 63 in. (1600 mm) to make part number L2643486X1600MM.

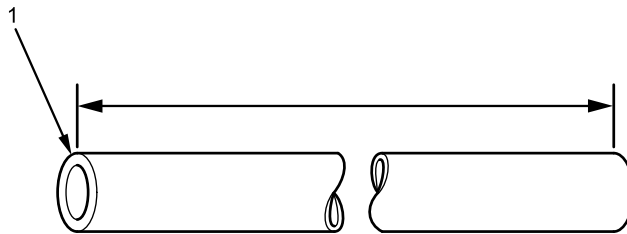

B230002908

Figure 3. Hose.

ILLUSTRATED LIST OF MANUFACTURED ITEMS - (CONTINUED)

2. For the two hoses inside the LSS box (part number L2643486X), cut length of bulk hose (Figure 3, Item 1) equal to length of hoses being replaced.
3. Cut length of bulk insulator (Figure 4, Item 1), part number 15210029168, at 60 in. (1520 mm) to make part number 15210029168X1520MM.

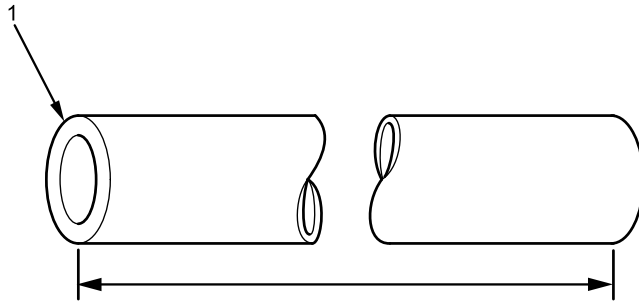

B230002907

Figure 4. Insulator.

Table 4. Material.

DESCRIPTION	PART NUMBER	CAGEC	NSN	QUANTITY
Hose, Heater, 3/4 in. (19 mm) ID x 50 ft (15.24 m)	L2643486	338X5	4720-01-269-4725	As required
Insulator, Hose, 1-1/8 in. (28.6 mm) ID	15210029168	81851	5999-01-556-4707	60 in. (1520 mm)

ILLUSTRATED LIST OF MANUFACTURED ITEMS - (CONTINUED)

AIR COMPRESSOR SUPPLY AIR LINE AND COOLANT HOSES

NOTE

Table 5 lists bulk materials from which items are manufactured.

1. Cut length of bulk hose (Figure 5, Item 1), part number L2643486, at 26 in. (660 mm) to make part number L2643486X660MM.

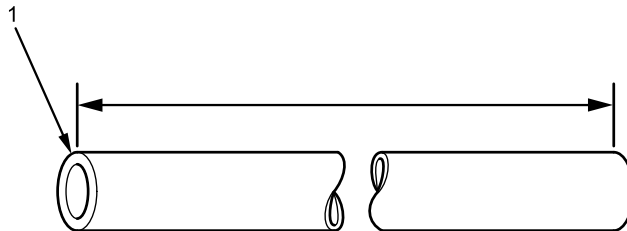

B230002908

Figure 5. Hose.

2. Cut length of bulk hose (Figure 5, Item 1), part number L2643505, at 9.5 in. (241.3 mm) to make part number L2643505X9.5IN.
3. Cut length of bulk hose (Figure 5, Item 1), part number L2643505, at 13 in. (330.2 mm) to make part number L2643505X13IN.

Table 5. Material.

DESCRIPTION	PART NUMBER	CAGEC	NSN	QUANTITY
Hose, Heater, 3/4 in. (19 mm) ID x 50 ft (15.24 m)	L2643486	338X5	4720-01-269-4725	26 in. (660 mm)
Hose, Coolant, 1/2 in. (12.7 mm) ID x 50 ft (15.24 m)	L2643505	338X5	4720-01-556-4812	Two pieces: 9.5 in. (241.3 mm) and 13 in. (330.2 mm)

ILLUSTRATED LIST OF MANUFACTURED ITEMS - (CONTINUED)

AIR CLEANER RESTRICTION GAUGE TUBES AND CONDUIT

NOTE

Table 6 lists bulk materials from which items are manufactured.

1. Cut length of bulk hose tubing (Figure 6, Item 1), part number 417196C3, at 39 in. (990 mm) to make part number 417196C3X990MM. This tube installs from the air cleaner housing to the coupler.

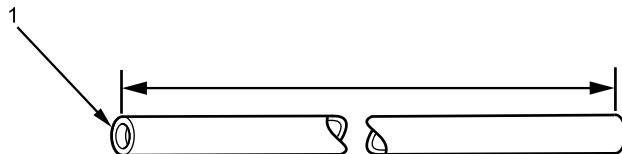

B230002916

Figure 6. Tube.

2. Cut length of bulk hose tubing (Figure 6, Item 1), part number 417196C3, at 54.3 in. (1380 mm) to make part number 417196C3X1380MM. This tube installs from the coupler to the air cleaner restriction gauge.
3. Cut length of conduit (Figure 7, Item 1), part number 2644094R1, at 37.6 in. (955 mm) to make part number 2644094R1X955MM.

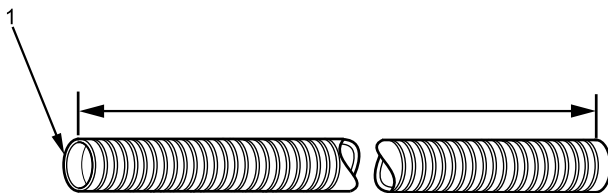

B230002917

Figure 7. Conduit.

Table 6. Material.

DESCRIPTION	PART NUMBER	CAGEC	NSN	QUANTITY
Tubing, Nonmetallic, 1/4 in. (6.35 mm) OD	417196C3	89346	4720-00-845-7189	Two pieces: 39 in. (990 mm) and 54.3 in. (1380 mm)
Conduit, 1/4 in. (6.35 mm) ID	2644094R1	338X5	5975-01-460-9996	37.6 in. (955 mm)

ILLUSTRATED LIST OF MANUFACTURED ITEMS - (CONTINUED)

GLADHAND TUBES, REAR BRAKE HOSE, AND FUEL FIRED HEATER SUPPLY HOSE INSULATORS

NOTE

Table 7 lists bulk materials from which items are manufactured.

1. Cut length of bulk hose insulator (Figure 8, Item 1), part number 3577746C1, at 23.6 in. (600 mm) to make part number 3577746C1X600MM.

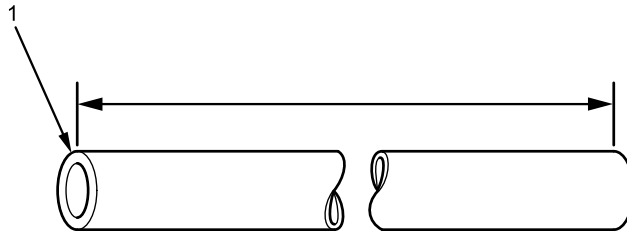

B230002908

Figure 8. Hose Insulator.

2. Cut length of bulk hose insulator (Figure 8, Item 1), part number 3577746C1, at 55.1 in. (1400 mm) to make part number 3577746C1X1400MM.
3. Cut length of bulk hose insulator (Figure 8, Item 1), part number 15210029168, at 14.8 in. (375 mm) to make part number 15210029168X375MM.
4. Cut length of bulk hose insulator (Figure 8, Item 1), part number 15210029168, at 19.7 in. (500 mm) to make part number 15210029168X500MM.
5. Cut length of bulk hose insulator (Figure 8, Item 1), part number 15210029168, at 21.3 in. (541 mm) to make part number 15210029168X541MM.

Table 7. Material.

DESCRIPTION	PART NUMBER	CAGEC	NSN	QUANTITY
Insulator, Hose, 3/4 in. (19 mm) ID	3577746C1	338X5	5975-01-556-6189	Two pieces: 23.6 in. (600 mm) and 55.1 in. (1400 mm)
Insulator, Hose, 1-1/8 in. (28.58 mm) ID	15210029168	81851	5999-01-556-4707	Three pieces: 14.8 in. (375 mm), 19.7 in. (500 mm), and 21.3 in. (541 mm)

ILLUSTRATED LIST OF MANUFACTURED ITEMS - (CONTINUED)

FUEL FIRED HEATER FUEL SUPPLY HOSE

NOTE

Table 8 lists bulk materials from which items are manufactured.

1. Cut length of bulk hose (Figure 9, Item 1), part number 2605751C1, at 94 in. (2388 mm) to make part number 2605751C1X2388MM.

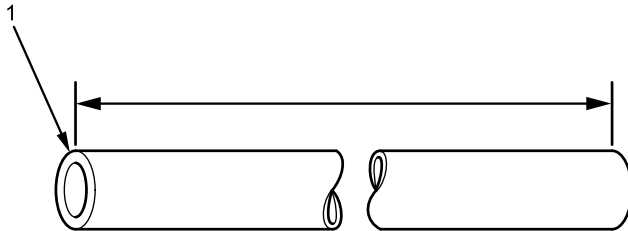

B230002908

Figure 9. Hose.

Table 8. Material.

DESCRIPTION	PART NUMBER	CAGEC	NSN	QUANTITY
Hose, Nonmetallic, 1/2 in. (12.7 mm) ID	2605751C1	338X5	4720-01-568-5983	94 in. (2388 mm)

ENGINE COOLING SYSTEM HOSES

NOTE

Table 9 lists bulk materials from which items are manufactured.

1. Cut length of bulk hose (Figure 10, Item 1), part number L2643504, at 11.8 in. (300 mm) to make part number L2643504X300MM.

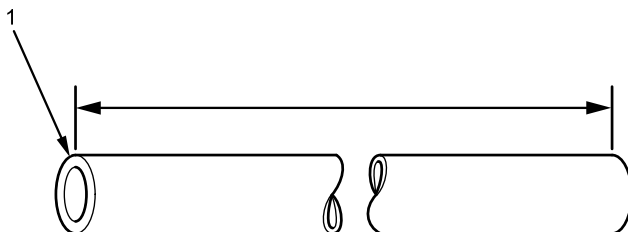

B230002908

Figure 10. Hose.

2. Cut length of bulk hose (Figure 10, Item 1), part number L2643504, at 26.6 in. (675 mm) to make part number L2643504X675MM.
3. Cut length of bulk hose (Figure 10, Item 1), part number L2643504, at 56.5 in. (1435 mm) to make part number L2643504X1435MM.

ILLUSTRATED LIST OF MANUFACTURED ITEMS - (CONTINUED)

- Cut length of bulk hose (Figure 10, Item 1), part number L2643493, at 13.5 in. (343 mm) to make part number L2643493X343MM.

Table 9. Material.

DESCRIPTION	PART NUMBER	CAGEC	NSN	QUANTITY
Hose, Heater, 3/8 in. (9.5 mm) ID	L2643504	89346	4720-01-512-4122	Three pieces: 11.8 in. (300 mm), 26.6 in. (675 mm), and 56.5 in. (1435 mm)
Hose, Heater, 1 in. (25.4 mm) ID	L2643493	89346	4720-01-556-4810	13.5 in. (343 mm)

FAN CLUTCH AIR HOSE TUBING

NOTE

Table 10 lists bulk materials from which items are manufactured.

- Cut length of bulk tubing (Figure 11, Item 1), part number 417196C3, at 12 in. (305 mm) to make part number 417196C3X12IN.

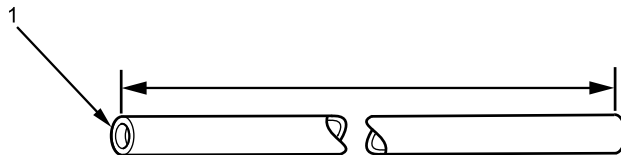

B230002916

Figure 11. Tube.

- Cut length of conduit (Figure 12, Item 1), part number 2644094R1, at 11.5 in. (292 mm) to make part number 2644094R1X.

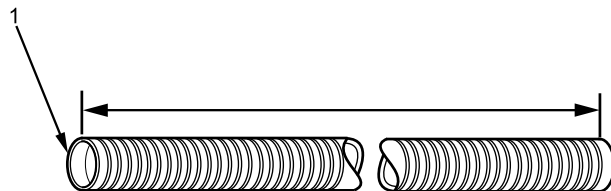

B230002917

Figure 12. Conduit.

ILLUSTRATED LIST OF MANUFACTURED ITEMS - (CONTINUED)

Table 10. Material.

DESCRIPTION	PART NUMBER	CAGEC	NSN	QUANTITY
Tubing, Nonmetallic, 1/4 in. (6.35 mm) OD	417196C3,	89346	4720-00-845-7189	12 in. (305 mm)
Conduit, 1/4 in. (6.35 mm) ID	2644094R1	338X5	5975-01-460-9996	11.5 in. (292 mm)

TRANSMISSION OIL COOLER HOSE INSULATOR

NOTE

Table 11 lists bulk materials from which items are manufactured.

1. Cut length of bulk hose insulator (Figure 13, Item 1), part number 2645001R1, at 24.4 in. (620 mm) to make part number 2645001R1X620MM.

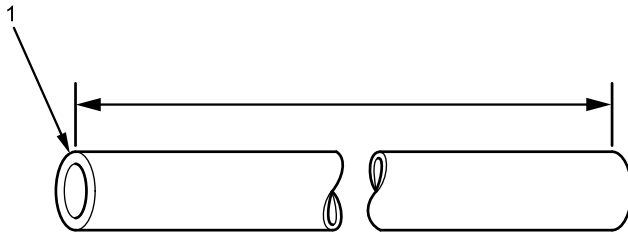

B230002908

Figure 13. Hose Insulator.

Table 11. Material.

DESCRIPTION	PART NUMBER	CAGEC	NSN	QUANTITY
Insulator, Hose, 1-1/2 in. (38.1 mm) ID	2645001R1	338X5	2590-01-568-6386	24.4 in. (620 mm)

ILLUSTRATED LIST OF MANUFACTURED ITEMS - (CONTINUED)

WINDSHIELD WASHER SUPPLY HOSES

NOTE

Table 12 lists bulk materials from which items are manufactured.

1. Cut length of bulk hose (Figure 14, Item 1), part number 92713800, at 22 in. (558.8 mm) to make part number 3113168C1LX22IN.

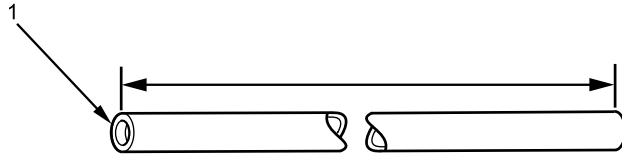

B230002916

Figure 14. Washer Supply Hose.

2. Cut length of bulk hose (Figure 14, Item 1), part number 92713800, at 90 in. (2286 mm) to make part number 3113169C1LX90IN.

Table 12. Material.

DESCRIPTION	PART NUMBER	CAGEC	NSN	QUANTITY
Hose, Rubber, 5/32 in. (4 mm) ID	92713800	338X5	N/A	Two pieces: 22 in. (558.8 mm) and 90 in. (2286 mm)

ILLUSTRATED LIST OF MANUFACTURED ITEMS - (CONTINUED)

AIR COMPRESSOR-TO-AIR DRYER AIR HOSE AND COPPER TUBE

NOTE

Table 13 lists bulk materials from which items are manufactured.

1. Cut length of bulk hose (Figure 15, Item 1), part number 375055C2, at 89.44 in. (2272 mm) to make part number 375055C2X89.44IN.

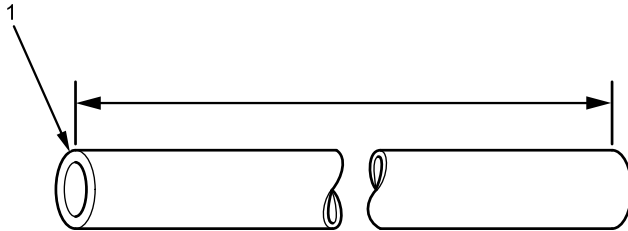

B230002908

Figure 15. Hose.

2. Cut length of bulk tubing (Figure 16, Item 1), part number 995509R2, at 36 in. (914 mm) to make part number 995509R2X914MM.

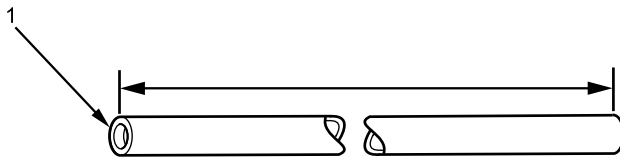

B230002916

Figure 16. Copper Tube.

Table 13. Material.

DESCRIPTION	PART NUMBER	CAGEC	NSN	QUANTITY
Hose, Teflon Air, 5/8 in. (15.9 mm) ID	375055C2	338X5	4720-01-556-4698	89.44 in. (2272 mm)
Tubing, Copper, 5/8 in. (15.9 mm) OD	995509R2	338X5	4710-01-065-6313	36 in. (914 mm)

ILLUSTRATED LIST OF MANUFACTURED ITEMS - (CONTINUED)

FRONT/REAR AXLE, TRANSFER CASE, AND FUEL TANK BREATHER HOSES

NOTE

Table 14 lists bulk materials from which items are manufactured.

1. Cut length of bulk hose (Figure 17, Item 1), part number L2643544, at 17.7 in. (450 mm) to make fuel tank breather hose part number L2643544X450MM.

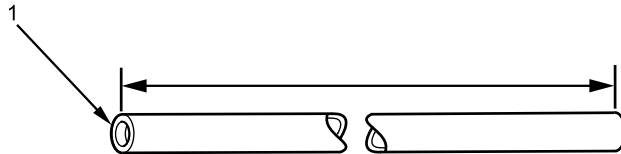

B230002916

Figure 17. Breather Hose.

2. Cut length of bulk hose (Figure 17, Item 1), part number L2643545, at 35.4 in. (900 mm) to make front axle breather hose part number L2643545X900MM.
3. Cut length of bulk hose (Figure 17, Item 1), part number L2643546, at 38.4 in. (975 mm) to make transfer case breather hose part number L2643546X975MM.
4. For the rear axle, cut bulk hose (Figure 17, Item 1), part number L2643546, equal to the length of hose being replaced.

Table 14. Material.

DESCRIPTION	PART NUMBER	CAGEC	NSN	QUANTITY
Hose, Nonmetallic, 5/16 in. (7.9 mm) ID	L2643544	89346	4720-01-038-7344	17.7 in. (450 mm)
Hose, Nonmetallic, 3/8 in. (9.53 mm) ID	L2643545	338X5	4720-01-065-0809	35.4 in. (900 mm)
Hose, Nonmetallic, 1/2 in. (12.7 mm) ID	L2643546	338X5	4720-01-372-1516	As required

ILLUSTRATED LIST OF MANUFACTURED ITEMS - (CONTINUED)

NONMETALLIC NYLON TUBING

NOTE

The following materials list and instructions apply to all nylon tubing not otherwise addressed in the Illustrated List of Manufactured Items.

Table 15 lists bulk materials from which items are manufactured.

Table 16 lists tube lengths by part number.

1. To make the required part number, cut length of bulk tube (Figure 18, Item 1) to dimension specified in Table 16.

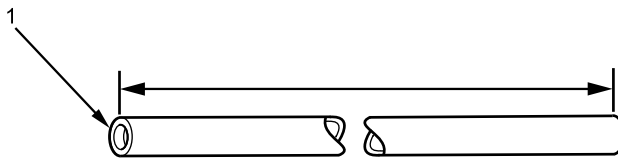

B230002916

Figure 18. Nonmetallic Nylon Tube.

2. For part numbers not listed in Table 16, cut length of bulk tube (Figure 18, Item 1) equal to length of tube being replaced.

Table 15. Material.

DESCRIPTION	PART NUMBER	CAGEC	NSN	QUANTITY
Tubing, Nonmetallic, 1/8 in. (3.18 mm) OD	417195C3	89346	4720-01-556-6545	750 mm
Tube, Nylon, 1/4 in. (6.35 mm) OD	417196C3	338X5	4720-00-845-7189	See Table 16.
Tube, Nylon, 3/8 in. (9.53 mm) OD	417199C3	338X5	4720-01-556-7114	See Table 16.
Tube, Nylon, 1/2 in. (12.7 mm) OD	417200C3	338X5	4720-01-513-0088	See Table 16.
Tube, Nylon, 5/8 in (15.88 mm) OD	417201C3	89346	4720-01-556-7118	See Table 16.
Tube, Nylon, 3/4 in (19.1 mm) OD	417202C3	89346	4720-01-347-7388	See Table 16.

ILLUSTRATED LIST OF MANUFACTURED ITEMS - (CONTINUED)

Table 16. Nylon Tube Lengths.

PART NUMBER	NAME	LENGTH
417195C3X750MM	Tube, Nylon, 1/8 in. (3.2 mm) OD	29.5 in. (750 mm)
417196C3X120IN	Tube, Nylon, 1/4 in. (6.35 mm) OD	120 in. (3048 mm)
417196C3X520MM.	Tube, Nylon, 1/4 in. (6.35 mm) OD	20.5 in. (520 mm)
417196C3X1050MM	Tube, Nylon, 1/4 in. (6.35 mm) OD	41.3 in. (1050 mm)
417196C3X1200MM	Tube, Nylon, 1/4 in. (6.35 mm) OD	47.2 in. (1200 mm)
417196C3X1250MM	Tube, Nylon, 1/4 in. (6.35 mm) OD	49.2 in. (1250 mm)
417196C3X1500MM	Tube, Nylon, 1/4 in. (6.35 mm) OD	59.1 in. (1500 mm)
417196C3X1800MM	Tube, Nylon, 1/4 in. (6.35 mm) OD	70.9 in. (1800 mm)
417199C3X340MM	Tube, Nylon, 3/8 in. (9.53 mm) OD	13.4 in. (340 mm)
417199C3X350MM	Tube, Nylon, 3/8 in. (9.53 mm) OD	13.8 in. (350 mm)
417199C3X450MM	Tube, Nylon, 3/8 in. (9.53 mm) OD	17.7 in. (450 mm)
417199C3X500MM	Tube, Nylon, 3/8 in. (9.53 mm) OD	19.7 in. (500 mm)
417199C3X750MM	Tube, Nylon, 3/8 in. (9.53 mm) OD	29.5 in. (750 mm)
417199C3X850MM	Tube, Nylon, 3/8 in. (9.53 mm) OD	33.5 in. (850 mm)
417199C3X1100MM	Tube, Nylon, 3/8 in. (9.53 mm) OD	43.3 in. (1100 mm)
417199C3X1450MM	Tube, Nylon, 3/8 in. (9.53 mm) OD	57.1 in. (1450 mm)
417199C3X1830MM	Tube, Nylon, 3/8 in. (9.53 mm) OD	72 in. (1830 mm)
417199C3X1960MM	Tube, Nylon, 3/8 in. (9.53 mm) OD	77.2 in. (1960 mm)
417199C3X2000MM	Tube, Nylon, 3/8 in. (9.53 mm) OD	78.7 in. (2000 mm)
417199C3X2450MM	Tube, Nylon, 3/8 in. (9.53 mm) OD	96.5 in. (2450 mm)
417199C3X3000MM	Tube, Nylon, 3/8 in. (9.53 mm) OD	118.1 in. (3000 mm)
417199C3X3100MM	Tube, Nylon, 3/8 in. (9.53 mm) OD	122 in. (3100 mm)
417200C3X300MM	Tube, Nylon, 1/2 in. (12.7 mm) OD	11.8 in. (300 mm)
417200C3X400MM	Tube, Nylon, 1/2 in. (12.7 mm) OD	15.7 in. (400 mm)
417200C3X800MM	Tube, Nylon, 1/2 in. (12.7 mm) OD	31.5 in. (800 mm)
417200C3X1000MM	Tube, Nylon, 1/2 in. (12.7 mm) OD	39.4 in. (1000 mm)
417200C3X1600MM	Tube, Nylon, 1/2 in. (12.7 mm) OD	63 in. (1600 mm)
417200C3X2750MM	Tube, Nylon, 1/2 in. (12.7 mm) OD	108.3 in. (2750 mm)
417201C3X800MM	Tube, Nylon, 5/8 in (15.88 mm) OD	31.5 in. (800 mm)
417201C3X2300MM	Tube, Nylon, 5/8 in (15.88 mm) OD	90.6 in. (2300 mm)
417202C3X1020MM	Tube, Nylon, 3/4 in (19.1 mm) OD	40.2 in. (1020 mm)

ILLUSTRATED LIST OF MANUFACTURED ITEMS - (CONTINUED)

POWER STEERING HOSE AND HOSE ARMOR

NOTE

Table 17 lists bulk materials from which items are manufactured.

1. Cut length of bulk loom (Figure 19, Item 1), part number 450017C1, at 28 in. (711 mm) to make part number 450017C1X711MM.

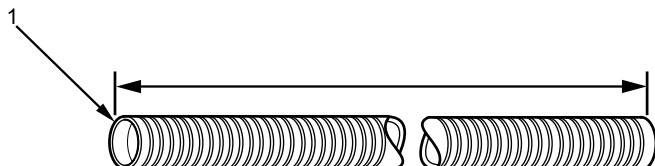

B231405923

Figure 19. Power Steering Hose Armor.

2. Cut length of bulk loom (Figure , Item 1), part number 584067C1, at 30.5 in. (774 mm) to make part number 584067C1X774MM.
3. Cut length of bulk hose (Figure 20, Item 1), part number L2643623, at 36 in. (915 mm) to make part number L2643623X915MM.

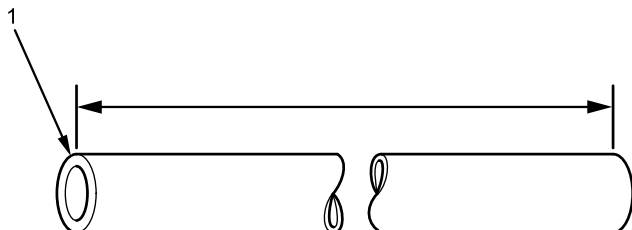

B230002908

Figure 20. Hose.

Table 17. Material.

DESCRIPTION	PART NUMBER	CAGEC	NSN	QUANTITY
Loom, Convoluted, 1 in. (25.4 mm) ID	450017C1	338X5	6150-01-556-6574	28 in. (711 mm)
Loom, Convoluted, 1-1/4 in. (30 mm) ID	584067C1	338X5	5975-01-556-6719	30.5 in. (774 mm)
Hose, Fuel and Oil, 1 in. (24.5 mm) ID	L2643623	338X5	4720-01-556-4816	36 in. (915 mm)

ILLUSTRATED LIST OF MANUFACTURED ITEMS - (CONTINUED)

STEERING COLUMN AIR BRAKE CONTROL HOSE CONDUIT

NOTE

Table 18 lists bulk materials from which items are manufactured.

1. Cut length of bulk conduit (Figure 21, Item 1), part number 2644081R1, at 32.5 in. (825 mm) to make part number 2644081R1X825MM.

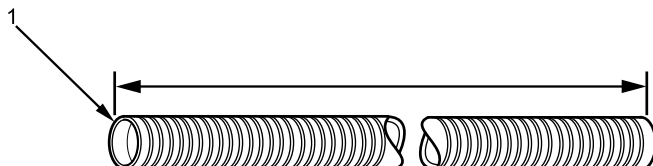

B231405923

Figure 21. Conduit.

Table 18. Material.

DESCRIPTION	PART NUMBER	CAGEC	NSN	QUANTITY
Conduit, Nylon, 1-1/2 in. (38 mm) ID	2644081R1	338X5	6145-01-556-5464	32.5 in. (825 mm)

COWL HOOD SEAL

NOTE

Table 19 lists bulk materials from which items are manufactured.

1. Cut length of bulk seal (Figure 22, Item 1), part number 3823241C1, at 80.7 in. (2050 mm) to make part number 3823241C1X2050MM.

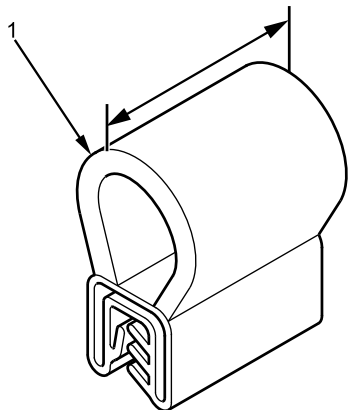

B230002926

Figure 22. Hood Seal.

ILLUSTRATED LIST OF MANUFACTURED ITEMS - (CONTINUED)**Table 19. Material.**

DESCRIPTION	PART NUMBER	CAGEC	NSN	QUANTITY
Seal, Rubber	3823241C1	338X5	5330-01-568-6062	80.7 in. (2050 mm)

ILLUSTRATED LIST OF MANUFACTURED ITEMS - (CONTINUED)

WINDOWS, INNER DOORS, AND UNDERBODY SEALS

NOTE

Table 20 lists bulk materials from which items are manufactured.

1. For the windows and inner doors, cut length of bulk trim tape (Figure 23, Item 1), part number 2693128C1, equal to length of seal being replaced.

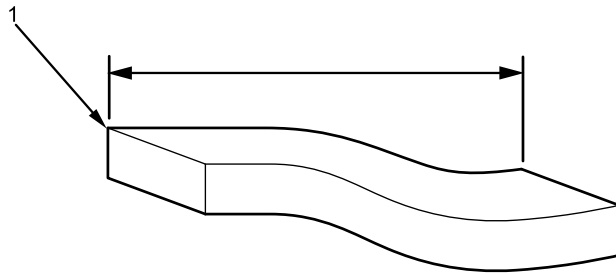

B230002927

Figure 23. Foam Trim Tape.

2. For the underbody, cut length of bulk trim tape (Figure 23, Item 1), part number 3693128C1, at 102 in. (2591 mm) to make part number 3693128C1X2591MM.

Table 20. Material.

DESCRIPTION	PART NUMBER	CAGEC	NSN	QUANTITY
Tape, Foam Trim, 0.2 in. (5 mm) x 0.79 in. (20 mm)	3693128C1	338X5	5330-01-567-0637	As required

POWER MIRROR HARNESS CONDUIT

NOTE

Table 21 lists bulk materials from which items are manufactured.

1. Cut length of bulk conduit (Figure 24, Item 1), part number 442498C1, at 62.2 in. (1580 mm) to make part number 442498C1X1580MM.

ILLUSTRATED LIST OF MANUFACTURED ITEMS - (CONTINUED)

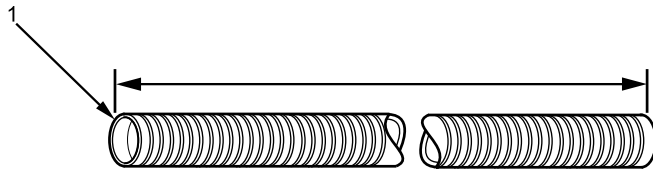

B231405923

Figure 24. Power Mirror Harness Conduit.

Table 21. Material.

DESCRIPTION	PART NUMBER	CAGEC	NSN	QUANTITY
Conduit, Nylon, 0.375 in. (9.5 mm) ID	442498C1	338X5	6150-01-568-5976	62.2 in. (1580 mm)

ILLUSTRATED LIST OF MANUFACTURED ITEMS - (CONTINUED)

FUEL FIRED HEATER FUEL LINE CONDUIT

NOTE

Table 22 lists bulk materials from which items are manufactured.

1. Cut length of bulk conduit (Figure 25, Item 1), part number 2644094R1, at 93.7 in. (2380 mm) to make part number 2644094R1X.

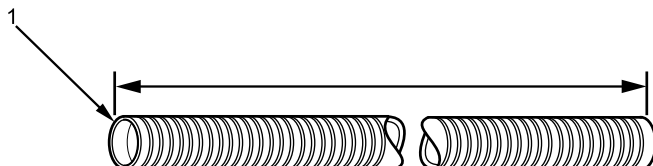

B231405923

Figure 25. Fuel Line Conduit.

Table 22. Material.

DESCRIPTION	PART NUMBER	CAGEC	NSN	QUANTITY
Conduit, Nylon, 1/4 in. (6.4 mm) ID	2644094R1	338X5	5975-01-460-9996	93.7 in. (2380 mm)

STORAGE BOX DOOR SEALS

NOTE

Table 23 lists bulk materials from which items are manufactured.

1. Cut length of bulk seal (Figure 26, Item 1), part number 3835432C1, equal to length of seal being replaced.

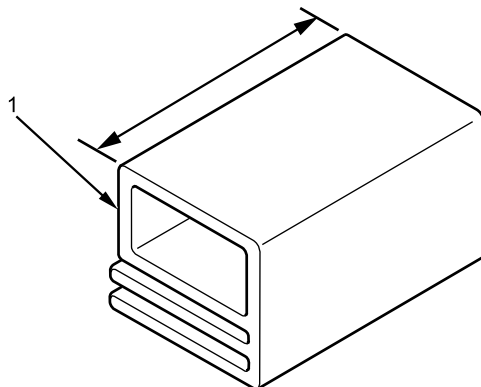

B231805842

Figure 26. Storage Box Door Seal.

ILLUSTRATED LIST OF MANUFACTURED ITEMS - (CONTINUED)**Table 23. Material.**

DESCRIPTION	PART NUMBER	CAGEC	NSN	QUANTITY
Seal, Rubber	3835432C1	338X5	5330-01-568-7351	As required

ILLUSTRATED LIST OF MANUFACTURED ITEMS - (CONTINUED)

C-CHANNEL TRIM MOLDING

NOTE

Table 24 lists bulk materials from which items are manufactured.

1. Cut length of bulk seal (Figure 27, Item 1), part number 2645520R1, at 6.69 in. (170 mm) and 9.1 in. (230 mm) to make the driver control carrier trim parts.

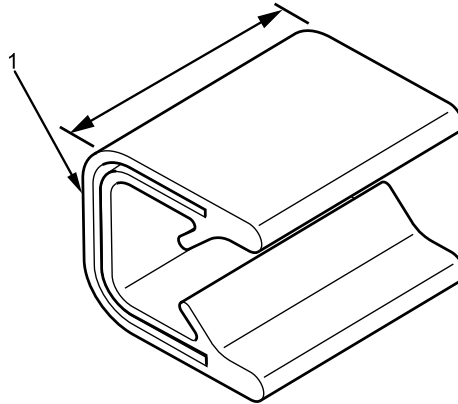

B231805838

Figure 27. C-Channel Trim Molding.

2. Cut length of bulk seal (Figure 27, Item 1), part number 2645520R1, at 4.5 in. (114.2 mm) to make part number 3861924C1X114.2MM.
3. Cut length of bulk seal (Figure 27, Item 1), part number 3692802C1, at 2 in. (51 mm) to make part number 3692802C1X51MM.
4. Cut length of bulk seal (Figure 27, Item 1), part number 3692802C1, at 6 in. (152 mm) to make part number 3692802C1X152MM.
5. Cut length of bulk seal (Figure 27, Item 1), part number 3692802C1, at 8 in. (203 mm) to make part number 3692802C1X203MM.
6. Cut length of bulk seal (Figure 27, Item 1), part number 3692802C1, at 18 in. (457 mm) to make part number 3692802C1X457MM.

Table 24. Material.

DESCRIPTION	PART NUMBER	CAGEC	NSN	QUANTITY
Molding, Trim, 0.23 in. (5.8 mm) wide channel	2645520R1	338X5	9390-01-587-3258	Three pieces: 4.5 in. (114.2 mm), 6.69 in. (170 mm), and 9.1 in. (230 mm)
Molding, Trim, 0.46 in. (11.7 mm) wide channel	3692802C1	338X5	9390-01-587-4624	Four pieces: 2 in. (51 mm), 6 in. (152 mm), 8 in. (203 mm) and 18 in. (457 mm)

ILLUSTRATED LIST OF MANUFACTURED ITEMS - (CONTINUED)

TRANSFER CASE OIL COOLER HOSE ASSEMBLIES

NOTE

Table 25 lists bulk materials from which items are manufactured.

The transfer case oil cooler hose assemblies are made from bulk hose, bulk conduit, and reusable hose fittings. The following two assembly part numbers are to be constructed using this procedure:

1. 3820521C92
2. 3821623C91
1. Cut length of bulk hose (Figure 28, Item 3), part number 375054C2, at 42.13 in. (1070 mm) to make part number 375054C2X1070MM.

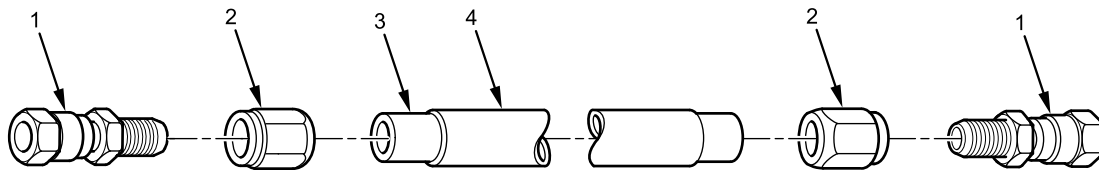

B230805836

Figure 28. Fittings, Conduit, and Hose.

2. Cut length of bulk hose (Figure 28, Item 3), part number 375054C2, at 73.6 in. (1870 mm) to make part number 375054C2X1870MM.
3. Cut length of bulk conduit (Figure 28, Item 4), part number 375048C1, at 38.2 in. (970 mm) to make part number 375048C1X970MM.
4. Cut length of bulk conduit (Figure 28, Item 4), part number 375048C1, at 69.7 in. (1770 mm) to make part number 375048C1X1770MM.
5. Assemble conduit (Figure 28, Item 4) onto hoses (Figure 28, Item 3). The hose should protrude approximately 2 in. (50 mm) at each end of conduit.
6. Install fitting socket (Figure 28, Item 2) on each end of both hoses.
7. Thread fitting nipples (Figure 28, Item 1) into sockets (Figure 28, Item 2) until they hit bottom, then back off one-half turn counterclockwise.

Table 25. Material.

DESCRIPTION	PART NUMBER	CAGEC	NSN	QUANTITY
Fitting, reusable	20620-6-8	87373	4730-01-419-4747	4
Hose, Nonmetallic, 1/2 in. (12.7 mm) ID	375054C2	338X5	4720-01-556-4697	Two pieces: 42.13 in. (1070 mm) and 73.6 in. (1870 mm)
Loom, Conduit, 0.875 in. (22.2 mm) ID	375048C1	338X5	5995-01-556-6338	Two pieces: 38.2 in. (970 mm) and 69.7 in. (1770 mm)

ILLUSTRATED LIST OF MANUFACTURED ITEMS - (CONTINUED)

HIGH PRESSURE INJECTION PUMP HOSE, CENTER HARNESS, AND GLADHANDS CONDUIT

NOTE

Table 26 lists bulk materials from which items are manufactured.

1. Cut length of bulk conduit (Figure 29, Item 1), part number 449632C1, at 7.75 in. (2380 mm) to make part number 1822646C1X7.75IN.

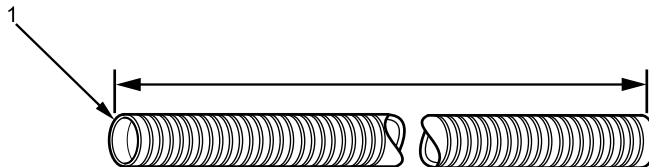

B231405923

Figure 29. Conduit.

2. Cut length of bulk conduit (Figure 29, Item 1), part number 2643669R1, at 11.8 in. (300 mm) to make part number 2643669R1X300MM.
3. Cut length of bulk conduit (Figure 29, Item 1), part number 449632C1, at 57.1 in. (1450 mm) to make part number 449632C1X1450MM.
4. Cut length of bulk conduit (Figure 29, Item 1), part number 449632C1, at 96.5 in. (2450 mm) to make part number 449632C1X2450MM.

Table 26. Material.

DESCRIPTION	PART NUMBER	CAGEC	NSN	QUANTITY
Conduit, Nylon, 2 in. (6 mm) ID	2643669R1	338X5	5340-01-556-5462	11.8 in. (300 mm)
Conduit, Nylon, 1/2 in. (12.7 mm) ID	449632C1	338X5	5975-01-556-6572	Three pieces: 7.75 in. (2380 mm), 57.1 in. (1450 mm), and 96.5 in. (2450 mm)

ILLUSTRATED LIST OF MANUFACTURED ITEMS - (CONTINUED)

REAR DOOR HYDRAULIC HOSE SLEEVE

NOTE

Table 27 lists bulk materials from which items are manufactured.

1. Cut length of bulk hose sleeve (Figure 30, Item 1), part number 3113865C1, at 16.5 in. (419.1 mm) to make part number 3113865C1X16.5IN.

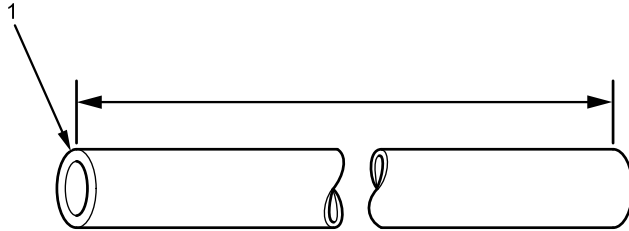

B230002908

Figure 30. Hose Sleeve.

Table 27. Material.

DESCRIPTION	PART NUMBER	CAGEC	NSN	QUANTITY
Sleeve, Hose	3113865C1	338X5	4720-01-567-7476	16.5 in. (419.1 mm)

END OF WORK PACKAGE

FIELD MAINTENANCE

TORQUE LIMITS

INTRODUCTION

This section provides general torque limits for fasteners. Special torque limits are indicated in the maintenance procedures for applicable components. The general torque limits given in this section shall be used when specific torque limits are not indicated in the maintenance procedure.

These general torque limits cannot be applied to fasteners that retain rubber components. The rubber components will be damaged before the correct torque limit is reached. If a special torque limit is not given in the maintenance instructions for fasteners retaining rubber components, tighten until it touches the metal bracket, then tighten it one more turn.

TORQUE LIMITS

Table 1 lists dry torque limits. Dry torque limits are used on fasteners that do not have lubricants applied to the threads. Table 2 lists wet torque limits. Wet torque limits are used on fasteners that have high pressure lubricants applied to the threads. For metric fasteners, refer to Table 3 for torque limit requirements.

HOW TO USE TORQUE TABLES

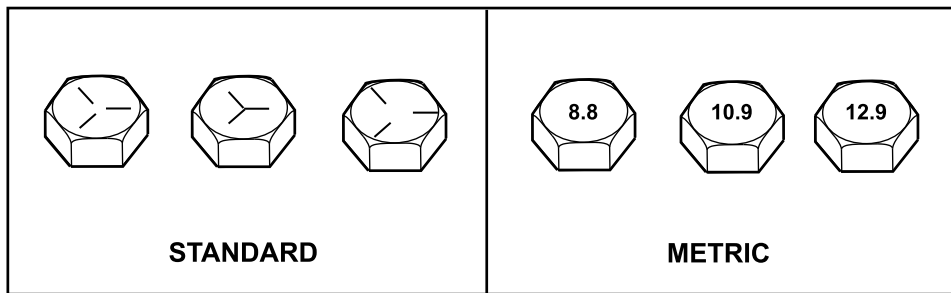

B230002661

Figure 1. Standard and Metric Fastener Markings.

Grades and manufacturer's marks appear on the fastener head. Manufacturer's marks may vary. Figure 1 shows all SAE Grade 5 (3-line) fasteners. Metric fasteners are of three grades: 8.8, 10.9, and 12.9.

Metric hex bolts M5 and larger must have the property class marked on the head of the bolt, either in raised or depressed lettering. Fasteners smaller than M5, and those with slotted or recessed heads, whatever their diameter, need not be marked. Radial lines, such as those used to mark SAE grades, are never used on metric bolts.

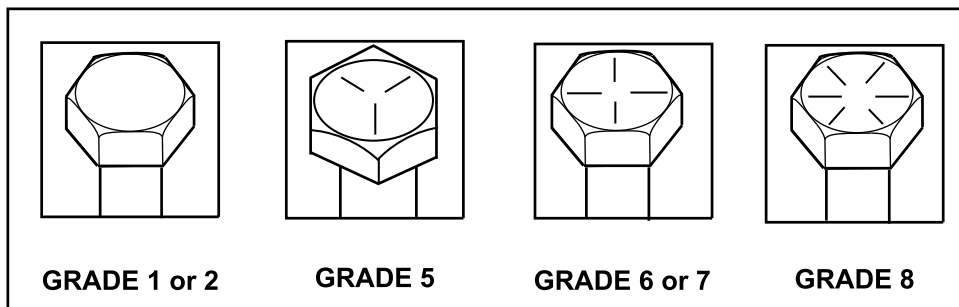

B230002662

Figure 2. Standard Fastener Grades.

TORQUE LIMITS - (CONTINUED)

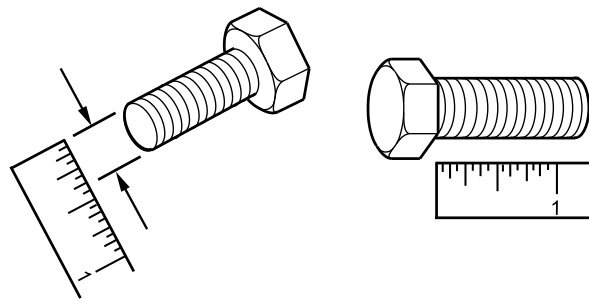

B230004743

Figure 3. Measuring Fastener.

1. Measure the diameter of the fastener you are installing (figure 3).
2. Count the number of threads per inch (figure 3).
3. Determine the grade of fastener by matching the markings on the head to figure 1 or 2.
4. Under the column heading SIZE in the Torque Limits tables, look down the left hand column and find the diameter of the fastener you are installing (there will usually be two lines beginning with the same size).
5. In the second column under SIZE, find the number of threads per inch that matches the number of threads you counted in step 2 (not required for metric fasteners).
6. Follow across the table to the grade that matches the fastener from step 3 until you find the torque limit (lb-ft or N•m) for the diameter and threads per inch of the screw.

Table 1. Torque Limits for Dry Fasteners.

SIZE			TORQUE							
			SAE GRADE 1 or 2		SAE GRADE 5		SAE GRADE 6 or 7		SAE GRADE 8	
DIA. INC- HES	THRE- ADS PER INCH	DIA. MM	LB-FT	N•m	LB-FT	N•m	LB-FT	N•m	LB-FT	N•m
1/4	20	6.35	5	6.78	8	10.85	10	13.56	12	16.27
1/4	28	6.35	6	8.14	10	13.56	-	-	14	18.98
5/16	18	7.94	11	14.92	17	23.05	19	25.76	24	32.54
5/16	24	7.94	13	17.63	19	25.76	-	-	27	36.61
3/8	16	9.53	18	24.41	31	42.04	34	46.10	44	59.66
3/8	24	9.53	20	27.12	35	47.46	-	-	49	66.44
7/16	14	11.11	28	37.97	49	66.44	55	74.58	70	94.92
7/16	20	11.11	30	40.68	55	74.58	-	-	78	105.77
1/2	13	12.70	39	52.88	75	101.7	85	115.26	105	142.38
1/2	20	12.70	41	55.6	85	115.26	-	-	120	162.72
9/16	12	14.29	51	69.16	110	149.16	120	162.72	155	210.18
9/16	18	14.29	55	74.58	120	162.72	-	-	170	230.52
5/8	11	15.88	63	85.43	150	203.4	167	226.45	210	284.76
5/8	18	15.88	95	128.82	170	230.42	-	-	240	325.44
3/4	10	19.05	105	142.38	270	366.12	280	379.68	375	508.5
3/4	16	19.05	115	155.94	295	400.02	-	-	420	569.52
7/8	9	22.23	160	216.96	395	535.62	440	596.64	605	820.38
7/8	14	22.23	175	237.3	435	589.86	-	-	675	915.3
1	8	25.4	235	318.66	590	800.04	660	894.96	910	1234
1	14	25.4	250	339	660	894.96	-	-	990	1342
1-1/8	-	28.58	-	-	840	1140	-	-	1360	1844
1-1/4	-	31.75	-	-	-	-	-	-	1910	2590
1-3/8	-	34.93	-	-	1570	2129	-	-	2550	3457
1-1/2	-	38.1	-	-	2070	2806	-	-	3360	4556

TORQUE LIMITS - (CONTINUED)

Table 2. Torque Limits for Wet Fasteners.

SIZE			TORQUE							
			SAE GRADE 1 or 2		SAE GRADE 5		SAE GRADE 6 or 7		SAE GRADE 8	
DIA. INC- HES	THRE- ADS PER INCH	DIA. MM	LB-FT	N•m	LB-FT	N•m	LB-FT	N•m	LB-FT	N•m
1/4	20	6.35	4.5	6.1	7.2	9.76	9	12.20	10.8	14.64
1/4	28	6.35	5.4	7.32	9	12.2	-	-	12.6	17.09
5/16	18	7.94	9.9	13.42	15.3	20.75	17.1	23.19	21.6	29.29
5/16	24	7.94	11.7	15.87	17.1	23.19	-	-	24.3	32.95
3/8	16	9.53	16.2	21.97	27.9	37.83	30.6	41.49	39.6	53.7
3/8	24	9.53	18	24.41	31.5	42.71	-	-	44.1	59.8
7/16	14	11.11	25.2	34.17	44.1	59.8	49.5	67.12	63	85.43
7/16	20	11.11	27	36.61	49.5	67.12	-	-	70.2	95.19
1/2	13	12.70	35.1	47.6	67.5	91.53	76.5	103.73	94.5	128.14
1/2	20	12.70	36.9	50.04	76.5	103.73	-	-	108	146.45
9/16	12	14.29	45.9	62.24	99	134.24	108	146.45	139.5	189.16
9/16	18	14.29	49.5	67.12	108	146.45	-	-	153	207.47
5/8	11	15.88	56.7	76.89	135	183.06	150.3	203.81	189	256.28
5/8	18	15.88	85.5	115.94	153.0	207.47	-	-	216.0	292.90
3/4	10	19.05	94.5	128.14	243.0	329.51	252.0	341.71	337.5	457.65
3/4	16	19.05	103.5	140.35	265.5	360.02	-	-	378.0	512.57
7/8	9	22.23	144.0	195.26	355.5	482.06	396.0	536.98	544.5	738.34
7/8	14	22.23	157.5	213.57	391.5	530.87	-	-	607.5	823.77
1	8	25.4	211.5	286.79	531.0	720.04	594	805.46	819	1110
1	14	25.4	225.0	305.10	594.0	805	-	-	891	1208
1-1/8	-	28.58	-	-	756	1025	-	-	1224	1660
1-1/4	-	31.75	-	-	-	-	-	-	1719	2331
1-3/8	-	34.93	-	-	1413	1916	-	-	2295	3112
1-1/2	-	38.1	-	-	1863	2526	-	-	3024	4100

Metric fastener sizes are referred to as M8 - 1.25 X 25, where M8 is the major thread diameter in millimeters, 1.25 is the distance between threads in millimeters, and 25 is the length in millimeters.

Table 3. Torque Limits for Metric Fasteners.

SIZE		TORQUE					
		METRIC GRADE 8.8		METRIC GRADE 10.9		METRIC GRADE 12.9	
DIA. INCHES	DIA. MM	LB-FT	N•m	LB-FT	N•m	LB-FT	N•m
0.237	6	5	9	10	13	9	14
0.276	7	9	14	14	18	18	23
0.315	8	17	23	25	33	29	40
0.394	10	33	45	50	65	50	70
0.473	12	60	80	85	115	95	125
0.552	14	90	125	133	180	145	195
0.630	16	140	195	200	280	210	290
0.709	18	200	280	285	390	290	400
0.788	20	290	400	400	550	-	-

END OF WORK PACKAGE

FIELD MAINTENANCE SCHEMATIC INTRODUCTION

INITIAL SETUP:
NOT APPLICABLE

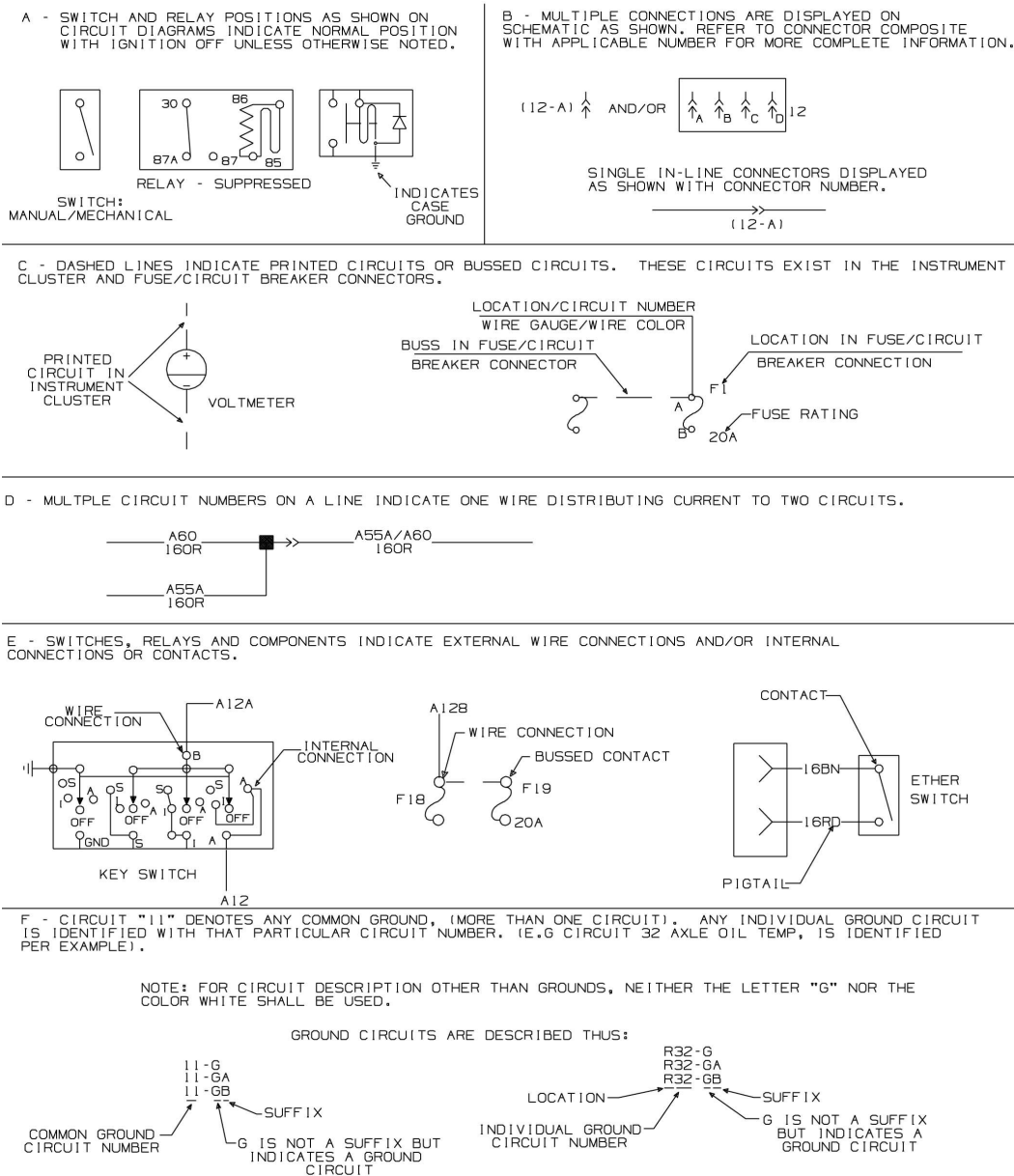

Figure 1. Circuit Diagram Instructions.

SCHEMATIC INTRODUCTION - (CONTINUED)

PREFIX DESIGNATIONS

PREFIX	LOCATION
A	CAB - INSTRUMENT PANEL
B	CAB - DRIVER CONTROL MODULE
C	CAB - HEADER / CLEARANCE LIGHTS
D	CAB - ROOF / REAR PANEL
E	CAB - LEFT DOOR
F	CAB - RIGHT DOOR
H	CAB - SLEEPER
J	CAB - DASH (OUTSIDE)
K	ENGINE / RADIATOR
L	TRANSMISSION
M	CHASSIS / FRONT END (CAB DASH PANEL FORWARD)
N	CHASSIS / CENTER SECTION (CAB DASH PANEL TO CAB RR XMBR)
P	CHASSIS / WHEEL BASE SECTION
R	CHASSIS / SUSPENSION / REAR AXLE / AXLES
S	CHASSIS / AF SECTION / STOP / TAIL / TURN LIGHTS

CIRCUIT NUMBER AND IDENTIFICATIONS

CIRCUIT NUMBER	COLOR	DESCRIPTION
1	LT BL	ALTERNATOR - FIELD
2	RD	ALTERNATOR - CHARGE
3	DK BL	SERIAL/DATA COMMUNICATION J1587 / J1708 (+)
3	GY	SERIAL/DATA COMMUNICATION J1587 / J1708 (-)
4		SERIAL/DATA COMMUNICATION J1922
5	YL	SERIAL/DATA COMMUNICATION J1939-11 / J1939-15 (+)
5	GN	SERIAL/DATA COMMUNICATION J1939-11 / J1939-15 (-)
6	GY	LOW VOLTAGE ELECTRONIC FEED (LESS THAN 9 VOLTS)
7	RD	ALTERNATOR - RESISTANCE
8		
9	GY	LOW VOLTAGE ELECTRONIC GROUND
10	WH	CHASSIS/ENGINE GROUND
11	WH	CAB/SLEEPER GROUND
12	LT BL	ACCESSORY FEED
13	PK	IGNITION FEED
13	BK	IGNITION FEED (BODY BUILDER CONNECTOR)
14	RD	BATTERY FEED
15	RD	KEY SWITCH FEED
16	RD	24 VOLT FEED
17	PK	STARTER CONTROL
18	PK	GLOW PLUG/PRE-HEATER
19	GY	ENGINE SHUTDOWN
20	LT GN	REMOTE POWER MODULE

Figure 2. Circuit Identification and Location Chart (1 of 4).

SCHEMATIC INTRODUCTION - (CONTINUED)

CIRCUIT NUMBER AND IDENTIFICATIONS (CONT.)

CIRCUIT NUMBER	COLOR	DESCRIPTION
21	TN	COLD START CONTROLS (ETHER)
22	TN	TIRE PRESSURE MONITORING/CONTROL
23	TN	ENGINE FAN/SHUTTERS
24	GY	ENGINE EXHAUST BRAKE
25	TN	PYROMETER
26	TN	AMMETER
27	TN	VOLTMETER
28	TN	INSTRUMENTS AND GAUGES
29	TN	ENGINE WATER TEMPERATURE
30	TN	ENGINE OIL TEMPERATURE
31	TN	TRANSMISSION OIL TEMPERATURE
32	TN	AXLE OIL TEMPERATURE
33	TN	ENGINE OIL LEVEL
34	TN	COOLANT LEVEL
35	TN	ENGINE OIL PRESSURE
36	TN	FUEL LEVEL
37	TN	FUEL PUMP
38	GY	LIFT AXLE
39	GY	AIR DRYER HEATER
40	GY	LOW AIR PRESSURE WARNING
41	TN	AIR TEMPERATURE
42	GY	FRONT AXLE ENGAGED
43	GY	POWER DIVIDER LOCK (PDL) WARNING
44	GY	PARK BRAKE WARNING
45	LTGN	ANTI - THEFT WARNING
46	GY	POWER TAKE - OFF WARNING
47	GY	SPEEDOMETER
48	GY	TACHOMETER
49	GY	DIFFERENTIAL LOCK WARNING
50	YL	LIGHT SWITCH FEED
51	YL	DIMMER SWITCH FEED
52	YL	HEADLIGHT HI-BEAM
53	YL	HEADLIGHT LO-BEAM
54	BN	PARKING/MARKER LIGHTS
55	OR	TURN SIGNAL - FEED
56	OR YL	TURN SIGNAL LIGHTS - LEFT TURN SIGNAL LIGHTS - LEFT (BODY BUILDER CONNECTION)
57	OR LTGN	TURN SIGNAL LIGHTS - RIGHT TURN SIGNAL LIGHTS - RIGHT (BODY BUILDER CONNECTION)

Figure 3. Circuit Identification and Location Chart (2 of 4).

SCHEMATIC INTRODUCTION - (CONTINUED)

CIRCUIT NUMBER AND IDENTIFICATIONS (CONT.)

CIRCUIT NUMBER	COLOR	DESCRIPTION
58	BN	CLEARANCE/IDENTIFICATION LIGHTS
59	GY	SOLENOID
60	OR	HAZARD LIGHTS
61	GY	AIR SUSPENSION
62	DKBL	PANEL LIGHTS
63	DKBL	COURTESY/DOME LIGHTS
64	YL	FOG/DRIVING LIGHTS
65	OR	CAB REAR FLOOD LIGHT
66	YL	DAYTIME RUNNING LIGHTS
67	GY	OBSTACLE AVOIDANCE/REMOTE SENSE
68	BN	TAIL LIGHTS
69	BN	LICENSE PLATE LIGHT
70	OR RD	STOP LIGHTS STOP LIGHTS (BODY BUILDER CONNECTION)
71	OR LTBL	BACK - UP LIGHTS BACK - UP LIGHTS (BODY BUILDER CONNECTION)
72	OR	TRAILER AUXILIARY FEED - BATTERY
73	LTGN	PWM
74	LTGN	HEATER RECIRC MOTOR
75	LTGN	HEATER BLOWER MOTOR
76	LTGN	AUXILIARY FAN
77	LTGN	AIR CONDITIONER
78	LTGN	MIRRORS - HEATED; MOTORIZED
79	GY	SEAT BELTS
80	BK	SLEEPER BOX RELAY - FEED
81	LTGN	POWER DOOR LOCKS
82	GY	WINDSHIELD WIPER
83	LTGN	POWER WINDOWS
84	LTGN	CIGAR LIGHTER
85	GY	HORN
86	LTGN	RADIO - ENTERTAINMENT
87	GY	WINDSHIELD WASHER
88	LTGN	CLOCK / HOURMETER
89	VT	AIR BAG
90	GY	HYDRAULIC BRAKE PUMP
91	VT	INTERCOMMUNICATIONS
92	TN	TRANSMISSION CONTROLS - ELECTRONIC
93	TN	AXLE SHIFT CONTROL
94	GY	ANTILOCK BRAKE SYSTEM
95	TN	EXHAUST EMISSION

Figure 4. Circuit Identification and Location Chart (3 of 4).

SCHEMATIC INTRODUCTION - (CONTINUED)

CIRCUIT NUMBER AND IDENTIFICATIONS (CONT.)

CIRCUIT NUMBER	COLOR	DESCRIPTION
96	YL	SNOW PLOW LIGHTS/CRUISE CONTROL
97	VT	ENGINE CONTROLS - ELECTRONIC
98	BK	DATALINK AND DIAGNOSTICS
99	VT	ACCELERATOR POSITION SENSOR (APS)
100	GY	AIR HORN (ELECTRIC SOLENOID ACTUATED)
101	TN	BRAKE APPLICATION AIR
102	YL	FLASH TO PASS
103	LTGN	BODY BUILDER AUX FEED
104	DKBL	REMOTE START/STOP
105	LTGN	HEATED SEATS
106	OR	HIGH VOLTAGE ALTERNATOR AC CHARGE
107	GY	INSTRUMENT CLUSTER ELECTRONIC FEED (5V)
108	GY	BRAKE PAD WEAR SENSORS
109	GY	SLACK ADJUSTER
110	GY	INSTRUMENT CLUSTER ELECTRONIC GROUND
111	TN	FUEL FILTER RESTRICTION TRANSDUCERS
112	GY	LIFT GATE
113	YL	BLACKOUT LIGHTS
114	YL	INFRARED LIGHTS

Figure 5. Circuit Identification and Location Chart (4 of 4).

SCHEMATIC INTRODUCTION - (CONTINUED)

SYMBOL	DESCRIPTION	SYMBOL	DESCRIPTION
	MALE/FEMALE IN-LINE CONNECTION		HORN
	FEMALE TERMINAL		MAGNETIC SWITCH
	MALE TERMINAL		
	GROUND		LIGHT - DOUBLE FILAMENT
	FUSE		
	LIGHT EMITTING DIODE		SENDER - OIL, WATER, FUEL, TEMPERATURE
	RESISTOR		
	SWITCH CONTACT, NORMALLY OPEN		MOTOR - ELECTRIC
	SWITCH CONTACT, NORMALLY CLOSED		
	JUNCTION POINT		SOLENOID - GENERAL USAGE
	SPLICE		
	SWITCH - PRESSURE		LIGHT - SINGLE FILAMENT
	SWITCH - MANUAL/ MECHANICAL		SPEAKER - SOUND SYSTEM
	RELAY - SUPPRESSED		CIGAR LIGHTER

B235001795

Figure 6. Symbols.

SCHEMATIC INTRODUCTION - (CONTINUED)

**RELAY FUNCTIONS
MINIATURE RELAY FUNCTION AND WIRING GUIDE**

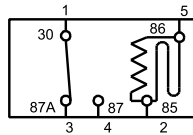

RELAY SCHEMATICS

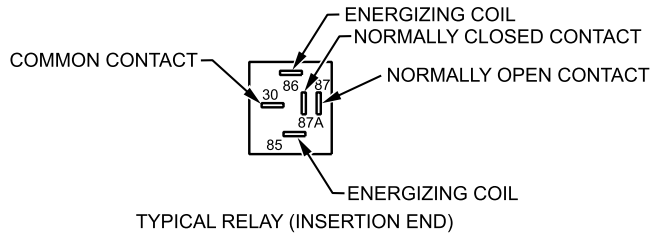

TYPICAL RELAY (INSERTION END)



FUSEBLOCK SOCKET
CONNECTOR SOCKET
CABLE INSERTION END

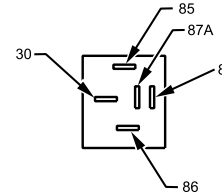

FUSEBLOCK SOCKET
CONNECTOR SOCKET
RELAY INSERTION END

**MICRO RELAY FUNCTION AND WIRING GUIDE
RELAY SCHEMATIC**

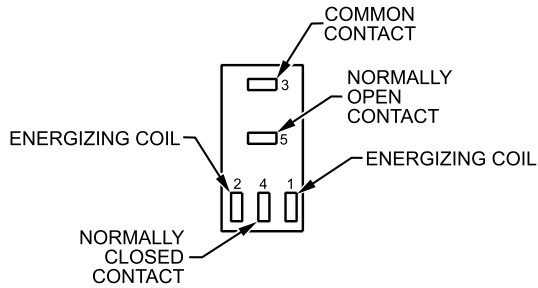
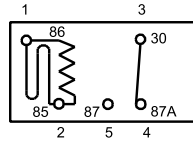

TYPICAL RELAY (INSERTION END)

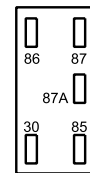

B235001783

Figure 7. Relay Functions.







SCHEMATIC INTRODUCTION - (CONTINUED)

G - ABBREVIATIONS: COLOR, NOUN AND ENGINE

COLOR ABBREVIATION

AQ - AQUA	LTGN - LIGHT GREEN
BK - BLACK	OR - ORANGE
BL - BLUE	PK - PINK
BN - BROWN	PL - PURPLE
DKGN - DARK GREEN	RD - RED
GD - GOLD	SIL - SILVER
GY - GRAY	TN - TAN
GN - GREEN	VT - VIOLET
LTBL - LIGHT BLUE	WH - WHITE
	YL - YELLOW

NOUN ABBREVIATION

A  ACCESSORY	G  GROUND
ACC  AIR CONDITIONER	GND  IGNITION
AC - AIR CONDITIONER	IGN  INDICATOR
AUX - AUXILIARY	IND - INDICATOR
AWG - AMERICAN WIRE GAUGE	L - LEFT
B  BATTERY	LT - LIGHT
BTRY  CONNECTION OR CONNECTOR	N/ - NOT WITH
CONN - CONNECTION OR CONNECTOR	W/O - WITHOUT
DRL - DAYTIME RUNNING LIGHTS	OPT - OPTIONAL
FWD - FORWARD	R - RIGHT
ENG - ENGINE	S - START OR SENDER
GA - GAUGE	THERMO - THERMOSTAT
	W/ - WITH

ENGINE ABBREVIATION

16-HEU1 - MFG (INTERNATIONAL) NGD 16 7.6 OR 8.7 LITER ELECTRONIC ENGINE CONTROL

B235001765

Figure 8. Abbreviations.

END OF WORK PACKAGE

FIELD MAINTENANCE
CONNECTOR LOCATIONS

INITIAL SETUP:

NOT APPLICABLE

Introduction

Connector locations are provided for all electrical circuits, electrical systems, and electronic systems covered in this technical manual.

Table 1. Connector Locations

Connector Number	Description	Location
254M	Power mirror switch	Center of Instrument Panel (IP)
1002	Panel light adapter splice pack	Center of IP
1003	Ground adapter	Center of IP
1010	Ether start switch	Left side of steering column on IP
1011	Fuse block 1	Right side IP
1012	Fuse block 2	Right side IP
1013	Fuse block 3	Right side IP
1014	Fuse block 4	Right side IP
1018	Left blower motor relay	Right side IP
1019	Right blower motor relay	Right side IP
1050	Blackout mode splice pack	Center of IP
1051	24V input	Right side IP
1052	Master Vehicle Light Switch (MVLS) ground	Center of IP
1053	Ground splice pack	Behind IP
1054	Negative stud	Left side IP
1055	Ground terminal	Left side IP
1100M	Key switch	Right side steering column on IP
1101M	Switch pack connector	Center of IP
1111	Dome light switch	Center of IP
1112	Heater interrupt switch	Center of IP
1150	Disconnect master power switch	Right side steering column on IP
1250	Heating, Ventilation, Air Conditioning (HVAC) interconnect switch	Below right side IP
1500	Cluster connector	Behind cluster
1520	Instrument Panel Cluster (IPC) blackout	IP near IP cluster
1521	24-volt meter	Center of IP
1155M	Optional warning light connector	Left IP
1600	Electronic System Controller (ESC) GRAY	Left of steering column on dash
1601	ESC BROWN	Left of steering column on dash
1650	Diagnostic connector	Left side IP under steering column
1658	J1939 telematics	Center of IP
1701	IP pass-through	Left side of IP, inside at dash
1701	Dash pass-through	Left side under hood at dash
1703F	Stop/turn light	Under left IP
1703M	Stop/turn light	Under left IP
1800	Cabin/Driver Control Module (DCM)	Right side of steering column
1804	Accelerator pedal	Firewall
1805	DCM/cabin	Right side of steering column
1808	Barometric Pressure (BAP) sensor	Left side of IP
1809	Clockspring	Steering column

CONNECTOR LOCATIONS - (CONTINUED)

Connector Number	Description	Location
1810	Turn signal switch	Steering column
1811	Primary air transducer	Left IP
1812	Secondary air transducer	Left IP
1813	Park brake transducer	Left IP
1822	Air application transducer	Left IP
1823	Stop light 1	Left IP
1824	Stop light 2	Left IP
1850	Battery feed megafuse to cab	Under hood, left side, above Power Distribution Center (PDC), output from 12V 100A megafuse
1851	Negative stud	Left side IP
1852	Transmission shifter 16-way	Shift bracket
1858B	Negative stud	Left side IP
1862	Negative stud	Left side IP
1876	Left turn relay	Center of IP
1877	Right turn relay	Center of IP
1878	Flash-to-pass relay	Center of IP
1936	Power socket ground	Left side IP
1937	Left side power socket	Center of IP
1938	Right side power socket	Center of IP
1939	Left heated windshield	Base of windshield
1940	Right heated windshield	Base of windshield
1951	Fuel-fired heater	Center of IP
1952	Infrared lamp switch	Center of IP
1953	Spotlight	Center of IP
1954	MVLS	Center of IP
1955	Ramp control switch	Center of IP
1956	Ramp control interconnect	Right side IP
2050	Roof marker	Right side IP
2101	Power stud	Under hood, left side, above PDC, input to 12V 100A megafuse
2118	Dome lamp connector	Right side IP
2400	Positive winch cable	Outboard right side frame rail, behind battery box, on 300A megafuse inboard stud
2401	Negative winch cable	Right inner wheel deflector bracket
2500	Positive winch cable	Behind front bumper, on front frame crossmember, upper junction block stud
2501	Negative winch cable	Behind front bumper, on front frame crossmember, lower junction block stud
3000M	Driver door connector	Left side IP near door
3003M	Passenger door connector	Right side IP near door
4001	Mini-fuse blocks	Power distribution center
4002	Micro-relay center	Power distribution center
4003	Isolation and power relays	Power distribution center
4004	ESC GRAY	Left of steering column on dash
4005	Ground 1	Under left side dash
4006	Ground 2	Under left side dash
4006A	Ground 3	Under left side dash
4007	ESC BROWN	Left of steering column on dash
4008	ESC BLUE	Left of steering column on dash
4015	Wiper motor inline connector	Under hood, left side of dash
4019	Air Conditioning (A/C) system	Underhood, right side near firewall
4021	Washer pump	Washer fluid reservoir
4025	Power stud	Brake valve armor
4028A	24V feed stud	Brake valve armor

CONNECTOR LOCATIONS - (CONTINUED)

Connector Number	Description	Location
4028C	24V feed stud	Brake valve armor
4034	Fuel-fired heater	Near left front shock
4035	Fuel-fired heater power and ground	Near left front shock
4036	Master power	Near left front shock
4042	Fuel heater	Water and fuel seperator
4043	Water probe	Water and fuel seperator
4100F	Dash connector	Under engine air cleaner
4101M	Dash connector starter/Engine Control Module (ECM) power	Under engine air cleaner
4103	Engine connector	Under engine air cleaner
4105	ECM power/starter solenoid	Under engine air cleaner
4111M	Fan solenoid	Under hood, left side of engine near dash
4300	Dash harness connector	Near left front shock
4301	Forward chassis connector	Near left front shock
4305M	Forward chassis connector	Near left front shock
4305F	Auxiliary dash connector	Near left front shock
4705F1	Dash/Transmission connector	Under engine air cleaner
4705F2	Dash/Transmission connector	Under engine air cleaner
4811	Electronic splice	Under engine air cleaner
4830	Electronic ground splice	Under engine air cleaner
4840	Ignition splice pack	Power distribution center under hood, on brake valve armor
4900	Transfer case connection	Near left front shock
4910	Transfer case connection	Near left front shock
4953	Anti-Lock Brake System (ABS) connector X1	Under right IP
4954	ABS connector X2	Under right IP
6007	ECM engine control	Left side of engine above starter at ECM
6102	Alternator power	Under hood, on alternator
6103	Alternator power	Under hood, on alternator
6104	Alternator ground	Under hood, on alternator
6105	Alternator ground	Under hood, on alternator
6106	Alternator ignition	Under hood, on alternator regulator
6108	12V disconnect switch	Outboard right side frame rail, behind battery box, on 12V solenoid inboard stud
6109	12V disconnect switch	Outboard right side frame rail, behind battery box, on 12V solenoid inboard stud
6302	Engine block ground	Left side of engine near starter
6306	Starter "S" terminal	On starter solenoid "S" terminal
6307	Engine block ground	Left side of engine near starter
6308	Starter power	On starter solenoid "B" terminal
6309	Starter power	On starter solenoid "B" terminal
6316	Engine block ground	Left side of engine near starter
6321	Engine block ground	Under hood, left side firewall
6322	Starter power	On starter solenoid "B" terminal
6323F	Engine ECM clean power	Front of starter
6323M	Engine ECM clean power	Front of starter
6401F	In-line 6 (I6) Hydraulic Electronic Unit Injector (HEUI) engine harness connection	Top of engine front
6401M	Low coolant sensor	Under hood, at coolant reservoir

CONNECTOR LOCATIONS - (CONTINUED)

Connector Number	Description	Location
6502	Exhaust brake solenoid	Engine, left side of rocker cover
6503	Exhaust brake solenoid ground	Engine, left side of rocker cover
6550M	Ether start thermostat	Under hood, rear of engine block near ECM
6703	Air temperature sensor	Under hood, air cleaner
6704	Ground splice connection	Under hood, on engine, above ECM
7104F	Transmission Control Module (TCM) clean power	Front of starter
7104M	TCM clean power	Front of starter
7150F	Transmission control module	Top of frame rail between transmission and fuel tank
7205F	Vehicle Interface Wiring (VIW)	Under engine air cleaner
7206M	VIW	Under engine air cleaner
7208M	J1939 transmission	Top of transmission right side
7210	ABS - 6 blink code switch	Left side of IP, left of steering column
7250F	Transmission connector	Right side of transmission
7603M	Engine speed sensor	Front of transmission
7605M	Transmission output speed sensor	Rear of transmission
7611	Transfer case	Left side rear transmission bellhousing
8000	Right headlight turn signal harness	Right side of front bumper
8001	Left headlight turn signal harness	Left side of front bumper
8153F	Left turn signal marker light in-line	Under left front fender
8153FR	Right turn signal marker light in-line	Under right front fender
8154	Left turn signal marker light	Under left front fender
8154R	Right turn signal marker light	Under right front fender
8311	Electric horn 1	Left side behind front bumper
8312	Electric horn 2	Right side behind front bumper
8400B	Ether start	Left front wheel well
8500	Left front ABS modulator valve	Left front wheel well
8501	Right front ABS modulator valve	Right front wheel well
8502A	Left front wheel speed sensor	Left front wheel well
8503A	Right front wheel speed sensor	Right front wheel well
8600	Radiator ground	Near radiator
8800	Ground adapter 1	Left front wheel well
8801	Ground adapter 2	Right front wheel well
8802	ISO ground and splice pack	Left side inside frame rail near transmission
8803	Chassis ground splice pack	Left side inside frame rail near transmission
9100	Left fuel sender	Fuel tank
9250	Battery positive	Battery positive post
9254	Engine ECM feed fuse connector	Battery tray
9255	TCM feed fuse connector	Battery tray
9256	Battery negative	Battery negative post
9260	Battery ECM negative connector	Battery tray
9261	Battery ECM positive connector	Battery tray
9303A	Stop and turn blackout	Rear of vehicle
9501	Left wheel speed sensor	Left rear brake actuator
9502	Left modulator	Left frame rail above rear axle
9503	Right speed sensor	Right rear brake actuator
9504	Right modulator	Right frame rail above axle
9700	Dash/center chassis interconnect	Near left front shock
9714	Dash/center chassis interconnect	Near left front shock
9715	Trailer socket 1 center chassis	Inside left frame rail behind transfer case
9715F	Trailer socket 1 rear chassis	Inside left frame rail behind transfer case
9715M	Trailer socket 1 center chassis	Near left front shock
9715P	Trailer socket 1 dash harness	Near left front shock

CONNECTOR LOCATIONS - (CONTINUED)

Connector Number	Description	Location
9716	Trailer socket 2 center chassis	Inside left frame rail behind transfer case
9716F	Trailer socket 2 rear chassis	Near left front shock
9716M	Trailer socket 2 rear chassis	Inside left frame rail behind transfer case
9716P	Trailer socket 2 center chassis	Near left front shock
9717	Trailer ground	Left frame rail behind transfer case
9717F	Trailer ground	Left frame rail behind transfer case
9717M	Trailer socket ground	Under hood, left side on firewall
9720	Blackout lighting	Above muffler near bumper
9722	Trailer auxiliary	Near left front shock
9723	Front trailer socket 1	Near left front shock
9724	Front trailer socket 2	Near left front shock
9733	Trailer auxiliary socket	Near left front shock
9733	Trailer auxiliary socket	Near left front shock
9736	Air solenoid 4-pack	Inside left frame rail near transmission
9750	Transfer case	Top of transfer case
9754	Transfer case switch pigtail	Right rear of transfer case
9755	Transfer case speed	Top of transfer case
9778F	Trailer socket ground	Left rear frame rail near muffler
9779F	Trailer socket 2	Left rear frame rail near muffler
9780M	Trailer socket 1	Left rear frame rail near muffler
9783	Trailer auxiliary power	Left rear frame rail near muffler
9800	Connection to center harness	Inside left frame rail behind transfer case
9900C	Air dryer	Frame at rear of transfer case
9916	Blackout lighting	Left side front bumper
9917	Blackout marker	Right side front bumper
C1	Fire Suppression System (FSS) control panel	Center IP
C2	Engine fire suppression cylinder	Under right side on frame rail behind stowage bin
C3	Internal fire cylinder	Inside vehicle at internal FSS cylinder
C4	Fuel tank fire cylinder	Left side center of vehicle on frame rail
C6	Tire fire suppression cylinder	Above left side rear stowage box, behind panel
C7	Engine fire heat detector	Underside hood
C8	Cabin fire heat detector	Right side below IP on door hinge post
C9	Cabin bulkhead pass-through	Under right side IP at penetration dust panel
C10	Fire suppression harness at Power Distribution Module (PDM)	Lower center IP
C11	Engine bulkhead pass-through	Right side firewall
J2	PDM feed firewall	Inside cabin, under engine cover, on lower front of PDM
J5	24V IP feed harness	Inside cabin, under engine cover, on lower front of PDM
J10	Recycled Air (RA) temperature sensor interface	Inside HVAC box, upper compartment
J19	HVAC control 2	Under right side IP at penetration dust panel
J22	HVAC operator panel	Front side HVAC box
J33	Low-pressure switch signal circuit (harness side)	Right side firewall
J33	3-way valve interface	Right side firewall
J33	HVAC engine harness 3-way valve	Right side firewall
J34	Left HVAC control 2	Right side firewall
J34	Right HVAC control 2	Right side firewall

CONNECTOR LOCATIONS - (CONTINUED)

Connector Number	Description	Location
J34	Left condenser control	Right side firewall
J34	Right condenser control	Right side firewall
J36	Air conditioning compressor	Left side upper engine near A/C compressor
P1	HVAC control power	Lower center IP at PDM
P3	Left condenser control	Right side A/C condenser
P4	Right condenser control	Left side A/C condenser
P4	PDM feed harness	Inside cabin, right side of PDM
P5	RA motor harness at Climate Control Unit (CCU)	Lower front of HVAC box
P6	HVAC control in harness at CCU	Lower front of HVAC box
P8	RA motor	Inside HVAC box, upper compartment
P10	RA temp sensor	Inside HVAC box, upper compartment
P12	Trinary switch	Inside HVAC box, upper compartment
P14	Fresh Air (FA) motor harness at CCU	Lower front of HVAC box
P17	FA motor	Inside HVAC box, Nuclear, Biological, Chemical (NBC) filter area
P19	HVAC	Under right side IP at penetration dust panel
P20	HVAC control power at CCU	Lower front of HVAC box
P21	HVAC operator panel harness at CCU	Lower front of HVAC box
P22	HVAC operator panel	Front of HVAC box
P23	HVAC control harness at CCU	Lower front of HVAC box
P29	HVAC control in harness	Under right side IP at penetration dust panel
P31	Freeze switch	Inside HVAC box, upper compartment
P33	Low-pressure switch ground circuit (harness side)	Right side engine near A/C compressor
P33	3-way valve interface	Right side firewall area
P33	HVAC engine harness 3-way valve	Right side firewall area
P34	Left HVAC control 2	Right side firewall area
P34	Right HVAC control 2	Right side firewall area
P34	Left condenser control	Right side firewall area
P34	Right condenser control	Right side firewall area
P35	HVAC interconnect (clear)	Right side IP
P36	A/C compressor	Left side upper engine
4019	A/C system high idle	Right side firewall area
J37	A/C system high idle	Right side firewall area
J14	FA motor harness at CCU	Inside HVAC box, NBC filter area. (Connected to backside of CCU)
LAM1001	Internal spotlight connector	On forward roof, at center pass-through
LAM1002	Spotlight connector/switch IP	Behind IP center trim panel, on spotlight switch
LAM1003	Spotlight connector IP harness	Inside cabin, under right side of IP, below electrical center
LAM1004	External spotlight connector	On forward roof, at center pass-through
LAM1005	Spotlight connection	On forward roof, under spotlight
LAM1006	Spotlight	On forward roof, under spotlight
LAM1007	Left mirror jumper harness to door	Inside cabin, under left side of IP, behind left IP mounting bracket
LAM1008	Left power mirror	Outside left door, outboard of left mirror mounting plate
LAM1009	Left mirror jumper harness through mirror	Outside left door, outboard of left mirror mounting plate, on mirror assembly support bracket
LAM1010	Left mirror jumper harness in mirror	Outside left door, inside mirror housing
LAM1011	Camshaft position (CMP) sensor	Under hood, right side of engine front cover
LAM1012	Spotlight motor static drain wire connector IP	Behind IP center trim panel, behind 24V gauge

CONNECTOR LOCATIONS - (CONTINUED)

Connector Number	Description	Location
LAM1013	Engine oil pressure sensor	Under hood, right side of engine block, forward of fuel filter
LAM1014	Manifold absolute pressure sensor	Under hood, forward top of valve cover
LAM1015	Engine oil temperature	Under hood, left side of engine, near high-pressure oil pump
LAM1016	Injector pressure regulator	Under hood, left side of engine, on high pressure oil pump
LAM1018	Injector control pressure sensor	Under hood, right side of engine, above fuel filter adapter mount
LAM1019	ECM	Under hood, on engine left rear lower side
LAM1020	Fuel injector harness	Under hood, left side of valve cover
LAM1021	Dome lamp connector	Inside cabin, under right side of IP, below electrical center
LAM1022	Front crew light	Inside cabin, on roof, between front seats
LAM1023	Right rear crew light	Inside cabin, on right side of roof, rear of turret opening
LAM1024	Right rear crew light	Inside cabin, on right side of roof, rear of turret opening
LAM1025	Left rear crew light	Inside cabin, on left side of roof, near turret opening
LAM1026	Ramp limit	Inside right rear of cabin, under upper cabin molding
LAM1027	Ramp limit	Inside right rear of cabin, under upper cabin molding
LAM1028	Ramp limit switch	Inside right rear of cabin, right upper ramp/door opening
LAM1029	Spotlight motor static drain jumper/wire connector roof	On forward roof, under spotlight
LAM1030	Spotlight motor static drain wire/jumper IP harness	Behind IP center trim panel, behind 24V gauge
LAM1031	Spotlight motor static drain jumper/wire harness	Behind IP center trim panel, on 24V gauge stud
LAM1032	Left side power socket	Inside cabin, under center of IP, above PDM
LAM1033	Right side power socket	Inside cabin, under center of IP, above PDM
LAM1034	Turret power feed	Inside cabin, under engine cover, on lower front of PDM
LAM1035	Ramp feed harness	Inside cabin, under engine cover, on lower front of PDM
LAM1036	24V IP feed harness	Inside cabin, under engine cover, on lower front of PDM
LAM1037	PDM case ground	Inside cabin, forward of engine cover, on right side of PDM
LAM1038	Government Furnished Equipment (GFE) feed harness	Inside cabin, under engine cover, on lower front of PDM
LAM1039	Clearance lights cabin jumper harness	Inside cabin, under right side of IP, below electrical center
LAM1040	Engine coolant temperature sensor	Under hood, left side of engine, near front cover
LAM1041	24V IP feed harness	Inside cabin, under right side of IP, below electrical center
LAM1042	Right mirror jumper harness to door	Inside cabin, under right side of IP, behind right IP mounting bracket

CONNECTOR LOCATIONS - (CONTINUED)

Connector Number	Description	Location
LAM1043	PDM firewall ground	Inside cabin, under right side of IP, below electrical center, on firewall
LAM1044	24V body feed harness connector	Under hood, right side firewall
LAM1045	Ground cable firewall	Under hood, right side firewall
LAM1046	Left headlight turn signal harness	Under hood, outboard left frame rail, forward of left front tire
LAM1047	Right headlight turn signal harness	Under hood, outboard right frame rail, forward of right front tire
LAM1048	Left headlight	Under hood, underside of left front fender
LAM1049	Right headlight	Under hood, underside of right front fender
LAM1050	Right power mirror	Outside right door, outboard of right mirror mounting plate
LAM1051	Right mirror jumper harness through mirror	Outside right door, outboard of right mirror mounting plate, on mirror assembly support bracket
LAM1052	Right mirror jumper harness in mirror	Outside right door, inside mirror housing
LAM1053	Ramp control interconnect	Inside cabin, under right side of IP, below electrical center
LAM1054	Engine valve cover pass-through connector	Under hood, left side of valve cover
LAM1055	Fuel injector cylinder #1	Under hood, under valve cover, #1 injector
LAM1056	Fuel injector cylinder #2	Under hood, under valve cover, #2 injector
LAM1057	Fuel injector cylinder #3	Under hood, under valve cover, #3 injector
LAM1058	Fuel injector cylinder #4	Under hood, under valve cover, #4 injector
LAM1059	Fuel injector cylinder #5	Under hood, under valve cover, #5 injector
LAM1060	Fuel injector cylinder #6	Under hood, under valve cover, #6 injector
LAM1061	Left turn signal and marker light	Under hood, underside of left front fender
LAM1062	Right turn signal and marker light	Under hood, underside of right front fender
LAM1063	Ramp control harness	Inside right rear of cabin, under pump cover
LAM1064	Hydraulic station harness	Inside right rear of cabin, under pump cover
LAM1065	Diode 1	Inside right rear of cabin, under pump cover
LAM1066	Diode 2	Inside right rear of cabin, under pump cover
LAM1067	Diode 3	Inside right rear of cabin, under pump cover
LAM1068	Hydraulic solenoid valve	Inside right rear of cabin, under pump cover
LAM1069	Hydraulic solenoid valve	Inside right rear of cabin, under pump cover
LAM1070	Crew ramp switch	Inside right rear of cabin, under pump cover
LAM1071	Ramp feed harness	Inside right rear of cabin, under pump cover
LAM1072	Ramp feed harness	Inside right rear of cabin, under pump cover
LAM1073	Inverter 24V positive feed	Right stowage cabinet, forward of rear wheel
LAM1074	Inverter ground	Right stowage cabinet, forward of rear wheel
LAM1075	Solenoid 24V positive feed	Right stowage cabinet, forward of rear wheel
LAM1076	Solenoid 24V delivery	Right stowage cabinet, forward of rear wheel
LAM1077	Inverter 150A fuse 24V	Right stowage cabinet, forward of rear wheel
LAM1078	Inverter 150A fuse 24V feed	Right stowage cabinet, forward of rear wheel
LAM1079	Solenoid 12V positive control	Right stowage cabinet, forward of rear wheel
LAM1080	Solenoid ground control	Right stowage cabinet, forward of rear wheel
LAM1081	North Atlantic Treaty Organization (NATO) slave-to-150A fuse 24V supply	Right stowage cabinet, forward of rear wheel
LAM1082	Inverter ground supply	Right stowage cabinet, forward of rear wheel
LAM1083	NATO slave 24V positive feed	Right stowage cabinet, forward of rear wheel
LAM1084	NATO slave ground	Right stowage cabinet, forward of rear wheel
LAM1085	Taillamp harness 3-pin	Rear inboard right frame rail, above muffler
LAM1086	Taillamp harness 5-pin	Rear inboard right frame rail, above muffler
LAM1087	Left taillamp assembly	Inside left rear light housing

CONNECTOR LOCATIONS - (CONTINUED)

Connector Number	Description	Location
LAM1088	Right taillamp assembly	Inside right rear light housing
LAM1089	Left rear side marker light	Behind left rear side marker light housing, in left rear stowage box
LAM1090	Right rear side marker light	Behind right rear side marker light housing, in right rear stowage box
LAM1091	Left rear side marker light ground	Inside left rear side marker light housing
LAM1092	Right rear side marker light ground	Inside right rear side marker light housing
LAM1093	Left backup light	Inside left rear light housing
LAM1094	Right backup light	Inside right rear light housing
LAM1095	CCU case ground	Inside cabin, behind right side front seat, on CCU unit
LAM1096	24V body feed harness	Outboard right side frame rail, behind battery box, on 24V solenoid inboard stud
LAM1097	24V body feed connector	Outboard right side frame rail, behind battery box, on 24V solenoid inboard stud
LAM1098	Front bumper left harness 3-pin	Behind front bumper, left side
LAM1099	Front bumper left harness blackout driving light	Behind front bumper, left side
LAM1100	Front bumper left harness 5-pin	Outboard left frame rail, forward of right front tire
LAM1101	Front chassis harness 5-pin to left front bumper harness	Outboard right frame rail, forward of right front tire
LAM1102	Front bumper left harness ground eyelet	Behind front bumper, left side
LAM1103	Front bumper left harness light assembly	Behind front bumper, left side
LAM1104	Front bumper right harness light assembly	Behind front bumper, right side
LAM1105	Winch megafuse feed cable	Outboard right frame rail, behind battery box, on 24V solenoid outboard stud
LAM1106	Winch megafuse feed cable	Outboard right frame rail, behind battery box, on 300A megafuse outboard stud
LAM1107	Front chassis harness 5-pin- to-right front bumper harness	Outboard left frame rail, forward of left front tire
LAM1108	Front bumper right harness 5-pin	Outboard right frame rail, forward of right front tire
LAM1109	Front bumper right harness 1-pin	Behind front bumper, right side
LAM1110	Front bumper left harness 2-pin	Behind front bumper, left side
LAM1111	MVLS ground	Behind IP center trim panel, on MVLS
LAM1112	MVLS ground jumper	Behind IP center trim panel, behind MVLS
LAM1113	Ground cable wheel deflector	Right inner wheel deflector bracket
LAM1114	Battery 3 parallel jumper	Battery 3, positive clamp adapter
LAM1115	Battery 4 positive parallel jumper	Battery 4, positive clamp adapter
LAM1116	Battery 4 negative parallel jumper	Battery 3, negative clamp adapter
LAM1117	Battery 3 negative parallel jumper	Battery 4, negative clamp adapter
LAM1118	Battery 3 series jumper	Battery 3, negative clamp adapter
LAM1119	Battery 2 series jumper	Battery 2, positive clamp adapter
LAM1120	Battery 1 negative connector to starter	Battery 1, negative clamp adapter
LAM1121	Starter ground	On starter motor ground stud
LAM1122	Battery 2 negative to NATO slave connector	Battery 2, negative clamp adapter
LAM1123	Battery 3 positive connection to 24V mag switch	Battery 3, positive clamp adapter
LAM1124	24V mag switch feed	On starter solenoid "B" terminal

CONNECTOR LOCATIONS - (CONTINUED)

Connector Number	Description	Location
LAM1125	Battery 3 positive to NATO slave connector	Battery 3, positive clamp adapter
LAM1126	Left rear clearance light power	On rear of roof, under rear clearance light bar assembly
LAM1127	Left rear clearance light ground	On rear of roof, under rear clearance light bar assembly
LAM1128	Left center rear clearance light power	On rear of roof, under rear clearance light bar assembly
LAM1129	Left center rear clearance light ground	On rear of roof, under rear clearance light bar assembly
LAM1130	Center rear clearance light power	On rear of roof, under rear clearance light bar assembly
LAM1131	Center rear clearance light ground	On rear of roof, under rear clearance light bar assembly
LAM1132	Right center rear clearance light power	On rear of roof, under rear clearance light bar assembly
LAM1133	Right center rear clearance light ground	On rear of roof, under rear clearance light bar assembly
LAM1134	Right rear clearance light power	On rear of roof, under rear clearance light bar assembly
LAM1135	Right rear clearance light ground	On rear of roof, under rear clearance light bar assembly
LAM1136	Rear clearance lights - lamps side	On rear of roof, under rear clearance light bar assembly, beneath right upper rear armor plate
LAM1137	Rear clearance lights - harness side	On rear of roof, under rear clearance light bar assembly, beneath right upper rear armor plate
LAM1138	Front clearance lights - harness side	On front of roof, left of front clearance light bar assembly
LAM1139	Front clearance lights - lamps side	On front of roof, left of front clearance light bar assembly
LAM1140	Left front clearance light power	On front of roof, under front clearance light bar assembly
LAM1141	Left front clearance light ground	On front of roof, under front clearance light bar assembly
LAM1142	Left center front clearance light power	On front of roof, under front clearance light bar assembly
LAM1143	Left center front clearance light ground	On front of roof, under front clearance light bar assembly
LAM1144	Center front clearance light power	On front of roof, under front clearance light bar assembly
LAM1145	Center front clearance light ground	On front of roof, under front clearance light bar assembly
LAM1146	Right center front clearance light power	On front of roof, under front clearance light bar assembly
LAM1147	Right center front clearance light ground	On front of roof, under front clearance light bar assembly
LAM1148	Right front clearance light power	On front of roof, under front clearance light bar assembly
LAM1149	Right front clearance light ground	On front of roof, under front clearance light bar assembly
LAM1150	12V disconnect switch ground	Outboard right side frame rail, behind battery box, on 12V solenoid inboard switching stud
LAM1151	24V disconnect switch ground	Outboard right side frame rail, behind battery box, on 24V solenoid inboard switching stud

CONNECTOR LOCATIONS - (CONTINUED)

Connector Number	Description	Location
LAM1152	12V disconnect switch power	Outboard right side frame rail, behind battery box, on 12V solenoid outboard switching stud
LAM1153	24V disconnect switch power	Outboard right side frame rail, behind battery box, on 24V solenoid outboard switching stud
LAM1154	12V disconnect power feed	Outboard right side frame rail, behind battery box, on 12V solenoid outboard stud
LAM1155	Left side power socket 2	Inside cabin, behind right side front seat, on equipment rack, inside receptacle box
LAM1156	Left side power socket 1	Inside cabin, behind right side front seat, on equipment rack, inside receptacle box
LAM1157	Right side power socket 2	Inside cabin, behind left side front seat, on equipment rack, inside receptacle box
LAM1158	Right side power socket 1	Inside cabin, behind left side front seat, on equipment rack, inside receptacle box
LAM1159	Front equalizer negative terminal at body ground	Right inner wheel deflector bracket
LAM1160	Rear equalizer negative terminal at body ground	Right inner wheel deflector bracket
LAM1161	Rear equalizer negative terminal at body ground	Outboard right side frame rail, behind battery box
LAM1162	Rear equalizer negative terminal	Outboard right side frame rail, behind battery box, on rear equalizer ground terminal
LAM1163	Front equalizer 12V terminal	Outboard right side frame rail, behind battery box, on front equalizer 12V terminal
LAM1164	Front equalizer 24V terminal	Outboard right side frame rail, behind battery box, on front equalizer 24V terminal
LAM1165	Front equalizer cable at 12V solenoid	Outboard right side frame rail, behind battery box, on 12V solenoid inboard stud
LAM1166	Front equalizer cable at 24V solenoid	Outboard right side frame rail, behind battery box, on 24V solenoid inboard stud
LAM1167	Rear equalizer cable at 12V solenoid	Outboard right side frame rail, behind battery box, on 12V solenoid inboard stud
LAM1168	Rear equalizer cable at 24V solenoid	Outboard right side frame rail, behind battery box, on 24V solenoid inboard stud
LAM1169	Rear equalizer 12V terminal	Outboard right side frame rail, behind battery box, on rear equalizer 12V terminal
LAM1170	Rear equalizer 24V terminal	Outboard right side frame rail, behind battery box, on rear equalizer 24V terminal
LAM1171	Front and rear clearance lights roof pass-through, inside harness	On forward roof, at center pass-through
LAM1172	Front and rear clearance lights roof harness	On forward roof, at center pass through
LAM1173	Turret power feed	Inside cabin, behind right side front seat, on equipment rack, inside turret feed box
LAM1174	Turret power feed	Inside cabin, behind right side front seat, on equipment rack, inside turret feed box
LAM1175	Wiper motor at PDC	Right side, under hood, beneath PDC
LAM1176	Wiper motor	Under cowl panel, below windshield, at wiper motor
LAM1177	GFE feed harness	Inside cabin, behind left side front seat, on equipment rack, inside GFE box

CONNECTOR LOCATIONS - (CONTINUED)

Connector Number	Description	Location
LAM1178	GFE feed harness	Inside cabin, behind left side front seat, on equipment rack, inside GFE box
LAM1179	Steering wheel harness	Steering wheel
LAM1180	Cruise control on/off switch	Steering wheel
LAM1181	Cruise control set/resume switch	Steering wheel
LAM1182	Negative battery cable	Battery 1, ground clamp adapter
LAM1183	Negative battery cable	Right inner wheel deflector bracket
LAM1184	Positive battery cable with pigtail	Battery 2, positive clamp adapter
LAM1185	Positive battery cable with pigtail	Battery 2, positive clamp adapter
LAM1186	12V solenoid feed cable	Battery 2, positive clamp adapter
LAM1187	12V solenoid feed cable	Outboard right side frame rail, behind battery box, on 12V solenoid outboard stud
LAM1188	24V solenoid feed cable	Battery 4, positive clamp adapter
LAM1189	24V solenoid feed cable	Outboard right side frame rail, behind battery box, on 24V solenoid outboard stud
LAM1190	14V regulator harness connector	Under hood, on alternator regulator
LAM1191	28V regulator harness connector	Under hood, on alternator regulator
LAM1192	14V regulator harness connector	Under hood, on alternator regulator
LAM1193	28V regulator harness connector	Under hood, on alternator regulator
LAM1194	Fuel-fired heater	Outboard right side frame rail, behind stowage bin, forward of rear tire
LAM1195	Fuel-fired heater fuse holder	Outboard left side frame rail, behind fuel tank
LAM1196	Fuel-fired heater fuel pump	Outboard left side frame rail, behind fuel tank
LAM1197	Fuel-fired heater harness	Outboard left side frame rail, behind fuel tank
LAM1198	Fuel-fired heater power and ground harness	Outboard left side frame rail, behind fuel tank
LAM1199	Front trailer hookup harness trailer socket	Front bumper, left side
LAM1200	Rear trailer hookup harness trailer socket	Rear bumper, left side
LAM1201	Master rear door/ramp switch	Behind IP center trim panel, on master rear door/ramp switch
LAM1202	Ramp control switch	Behind IP center trim panel, behind master rear door/ramp switch
LAM1203	Left front turn signal and parking light	Under hood, underside of left front fender
LAM1204	Right front turn signal and parking light	Under hood, underside of right front fender
LAM1205	Dome lamp switch	Behind IP center trim panel, on dome lamp switch
LAM1206	Dome lamp switch jumper	Behind IP center trim panel, behind dome lamp switch
LAM1207	Hydraulic pump motor feed	Inside right rear of cabin, under pump cover
LAM1208	Rear trailer hookup harness auxiliary power	Rear, inboard left frame rail, forward of muffler
LAM1209	Rear trailer hookup harness ground	Rear, inboard left frame rail, forward of muffler
LAM1210	Rear trailer hookup harness taillights	Rear, inboard left frame rail, forward of muffler
LAM1211	Rear trailer hookup harness tail and turn lights	Rear, inboard left frame rail, forward of muffler
LAM1212	Front trailer hookup harness ground	Under hood, left side firewall, near PDC
LAM1213	Front trailer hookup harness power and ground	Under hood, behind left engine armor plate, near top of left front shock
LAM1214	Front trailer hookup harness tail, turn and brake lights	Under hood, behind left engine armor plate, near top of left front shock

END OF WORK PACKAGE

FIELD MAINTENANCE
ELECTRICAL SYSTEM SCHEMATICS

INITIAL SETUP:

NOT APPLICABLE

Abbreviations

Abbreviations are in accordance with ASME Y14.38.

WIRING DIAGRAMS

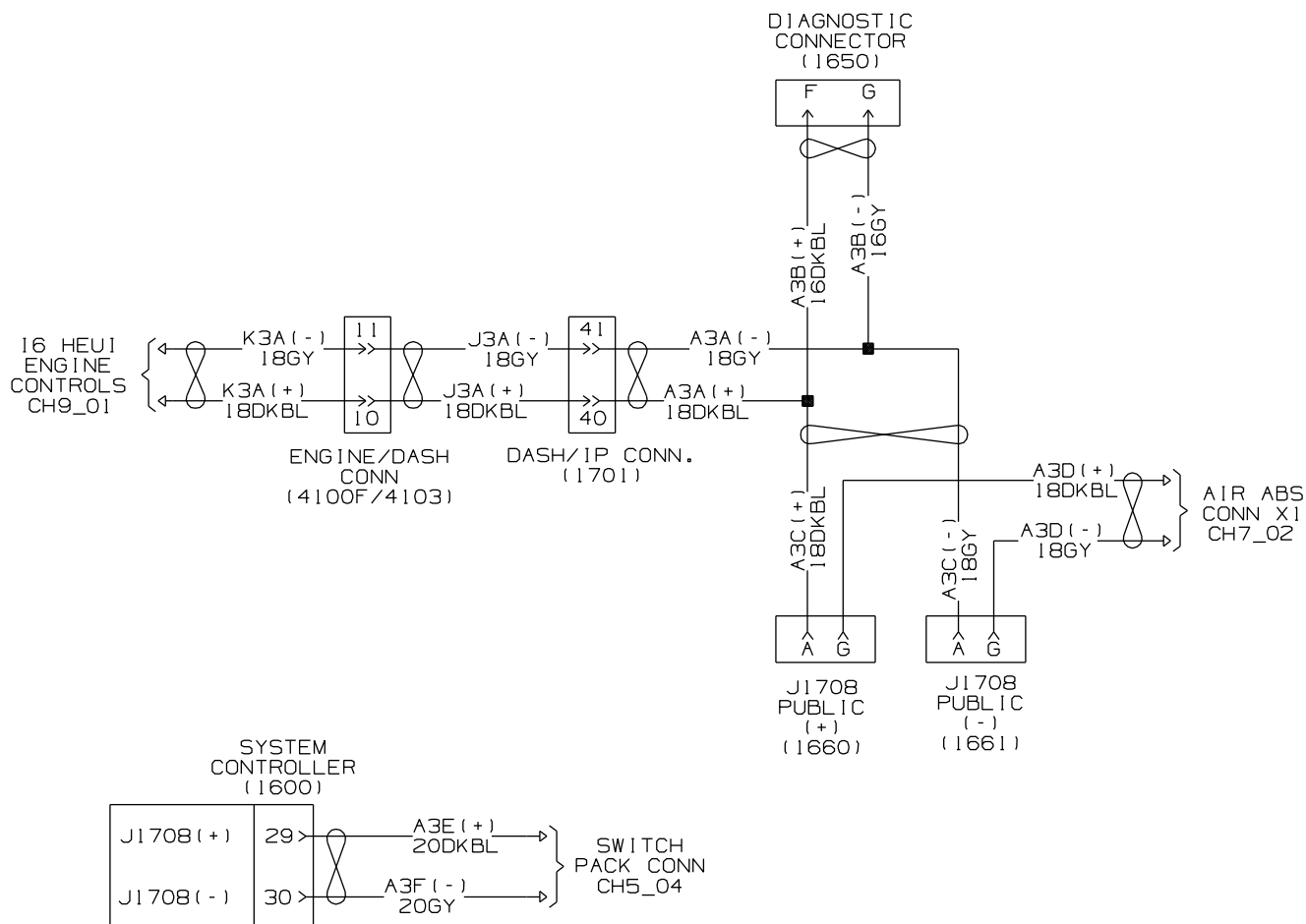

B235012351

Figure 1. CH2_01, J1708 Data Link.

ELECTRICAL SYSTEM SCHEMATICS - (CONTINUED)

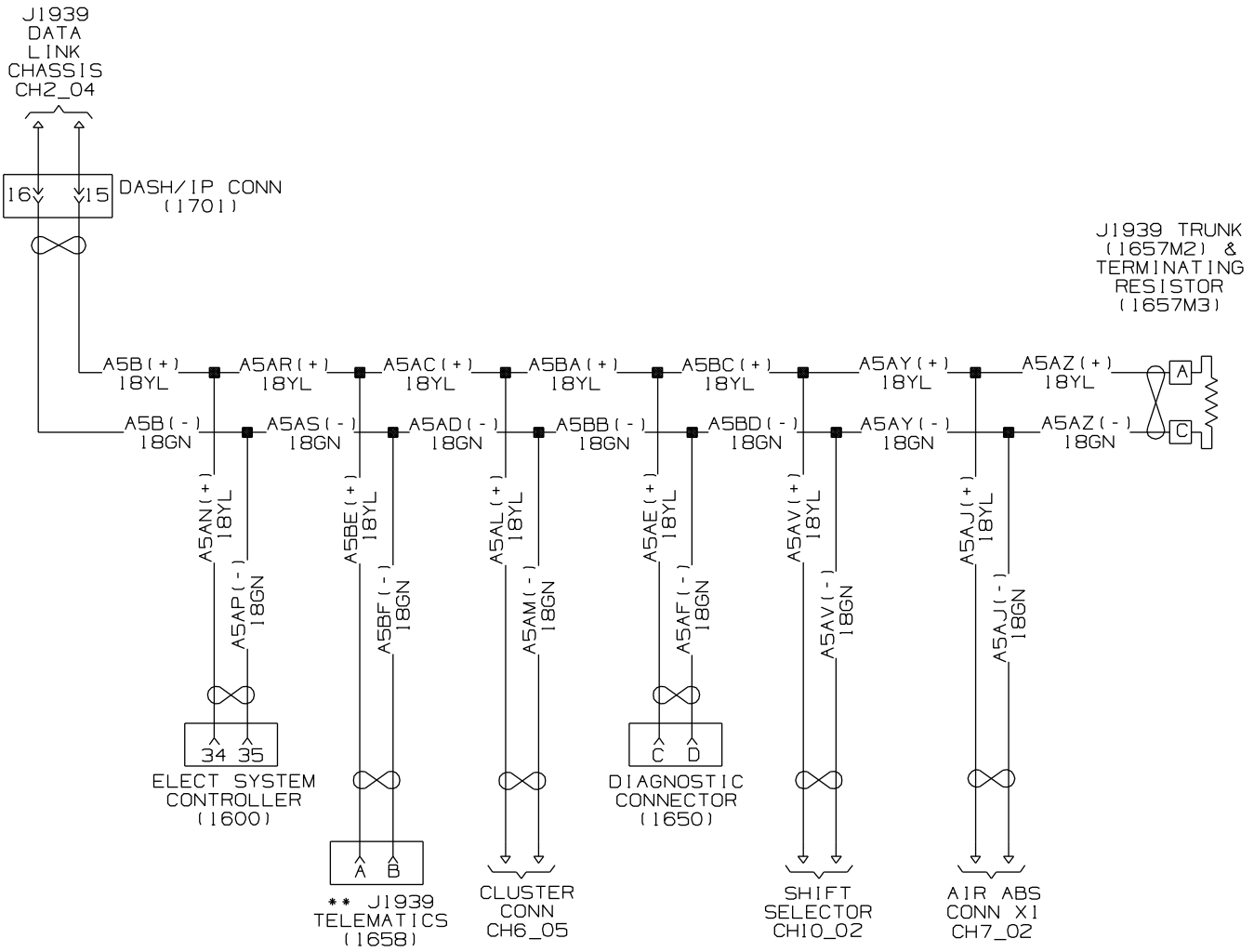

** NOTE: THIS IS CURRENTLY AN OPEN NODE THAT WAS INTENDED FOR TELEMATICS OR FOR FUTURE EXPANSION.

B235012352

Figure 2. CH2_02, J1939 Data Link – Cabin.

ELECTRICAL SYSTEM SCHEMATICS - (CONTINUED)

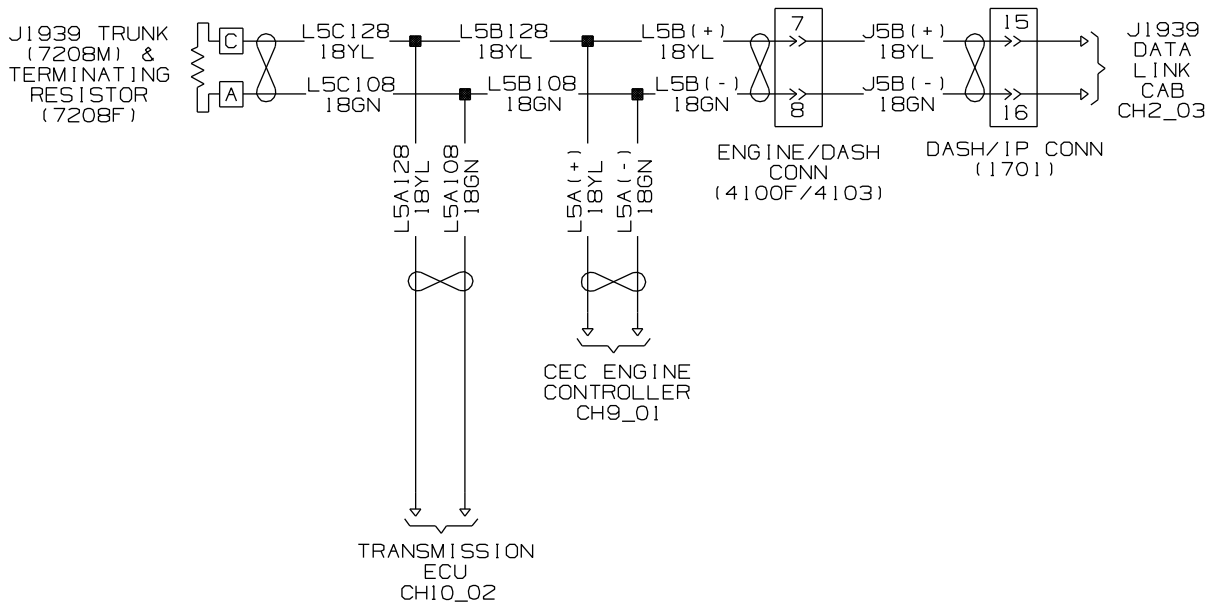

B235012353

Figure 3. CH2_03, J1939 Data Link – Chassis.

ELECTRICAL SYSTEM SCHEMATICS - (CONTINUED)

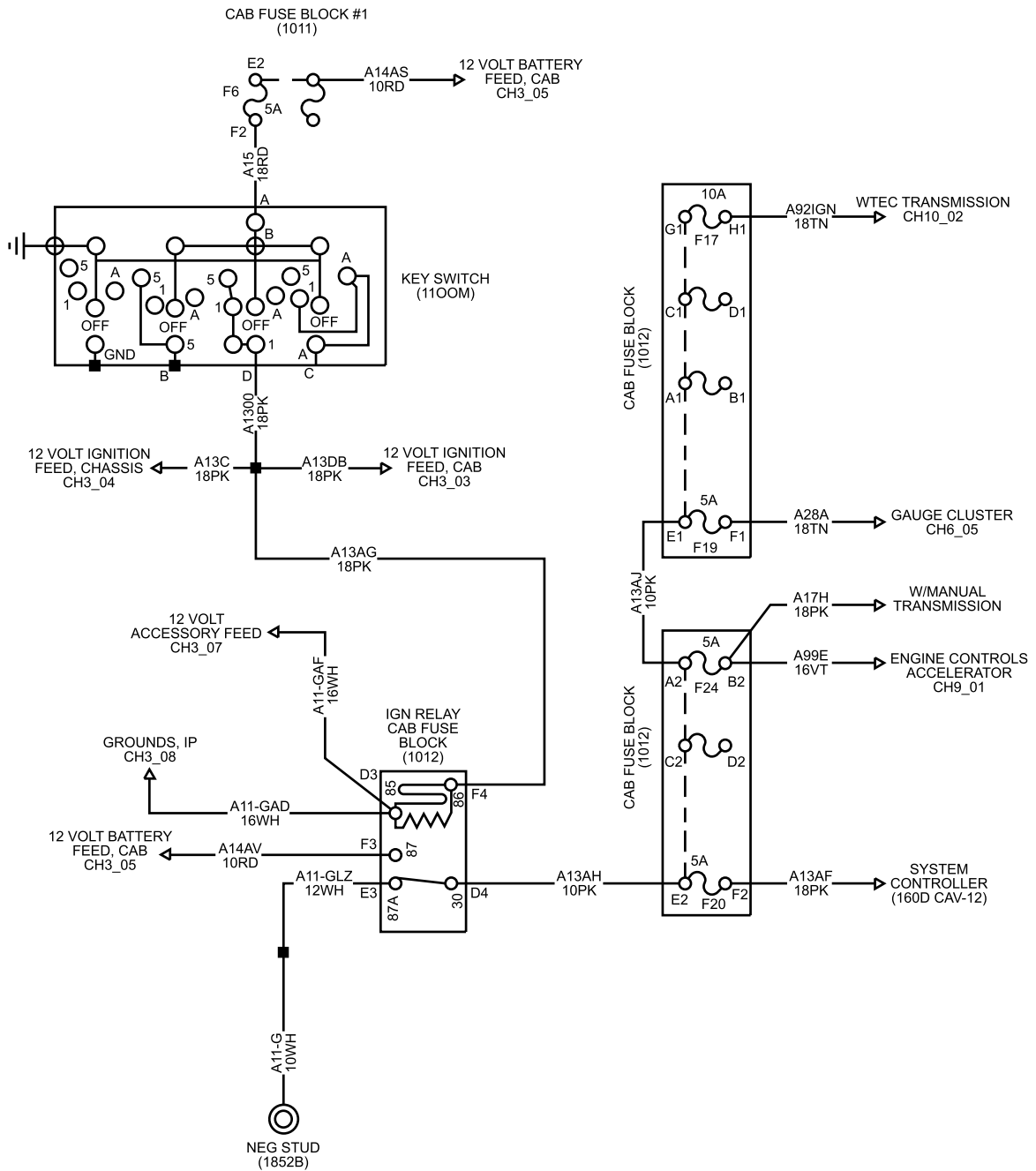

B235012355

Figure 5. CH3_02, 12V Ignition Feed – Cabin (1 of 2).

ELECTRICAL SYSTEM SCHEMATICS - (CONTINUED)

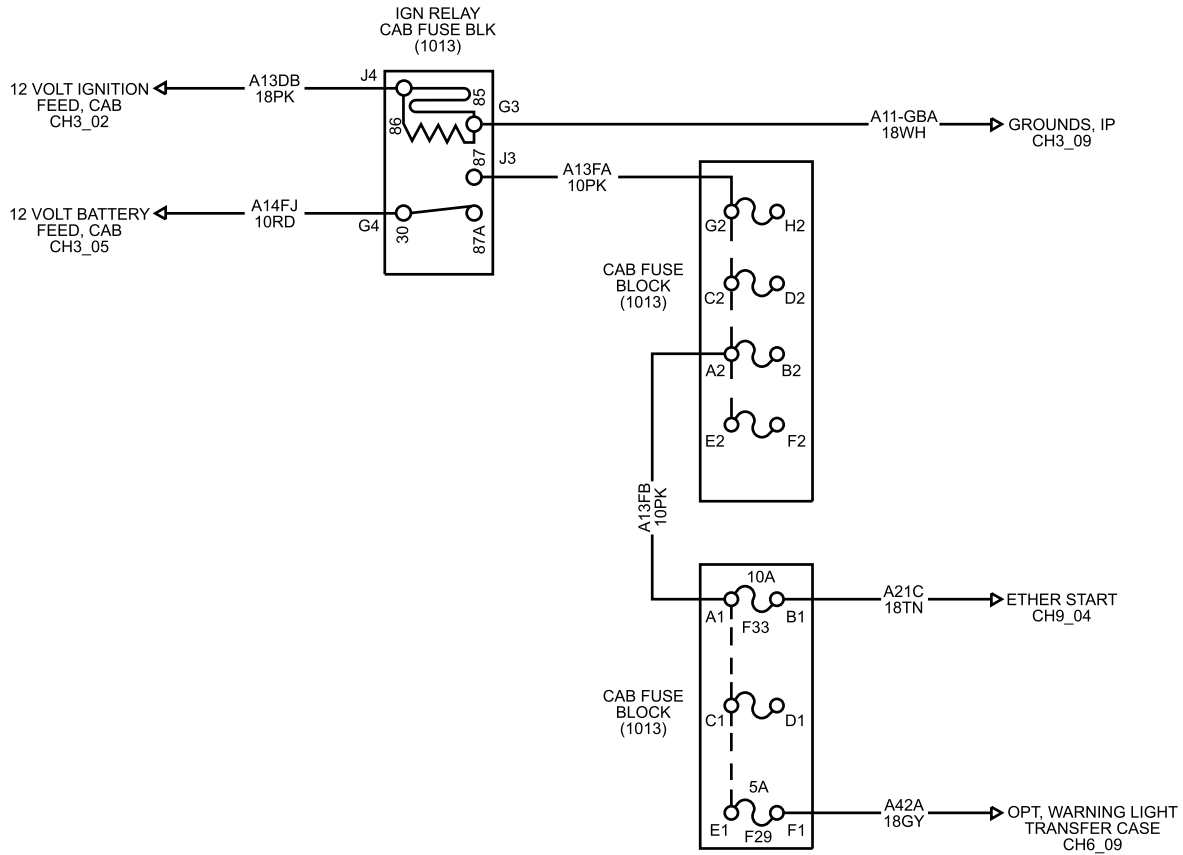

B235012356

Figure 6. CH3_03, 12V Ignition Feed – Cabin (2 of 2).

ELECTRICAL SYSTEM SCHEMATICS - (CONTINUED)

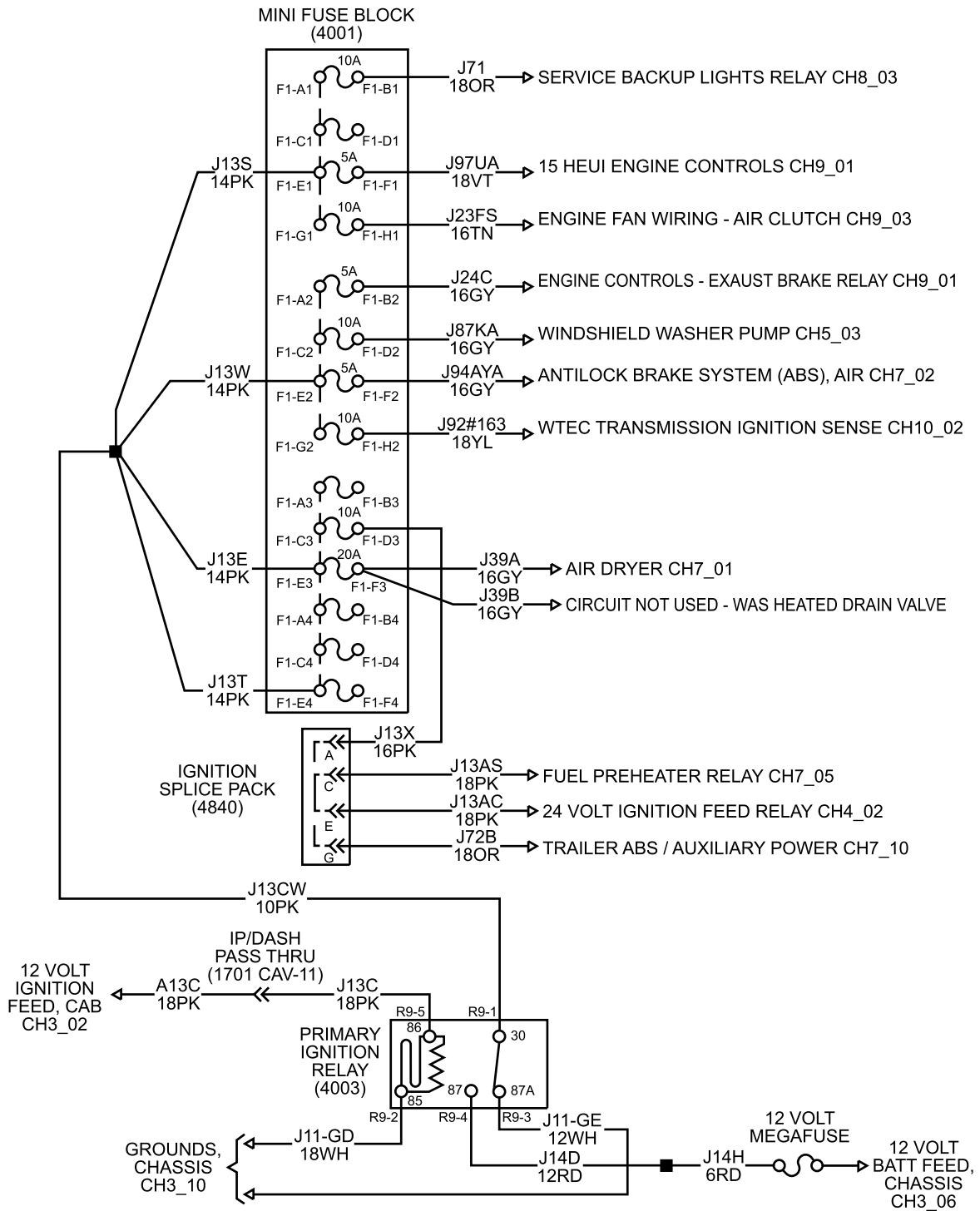

B235012357

Figure 7. CH3_04, 12V Ignition Feed – Chassis.

ELECTRICAL SYSTEM SCHEMATICS - (CONTINUED)

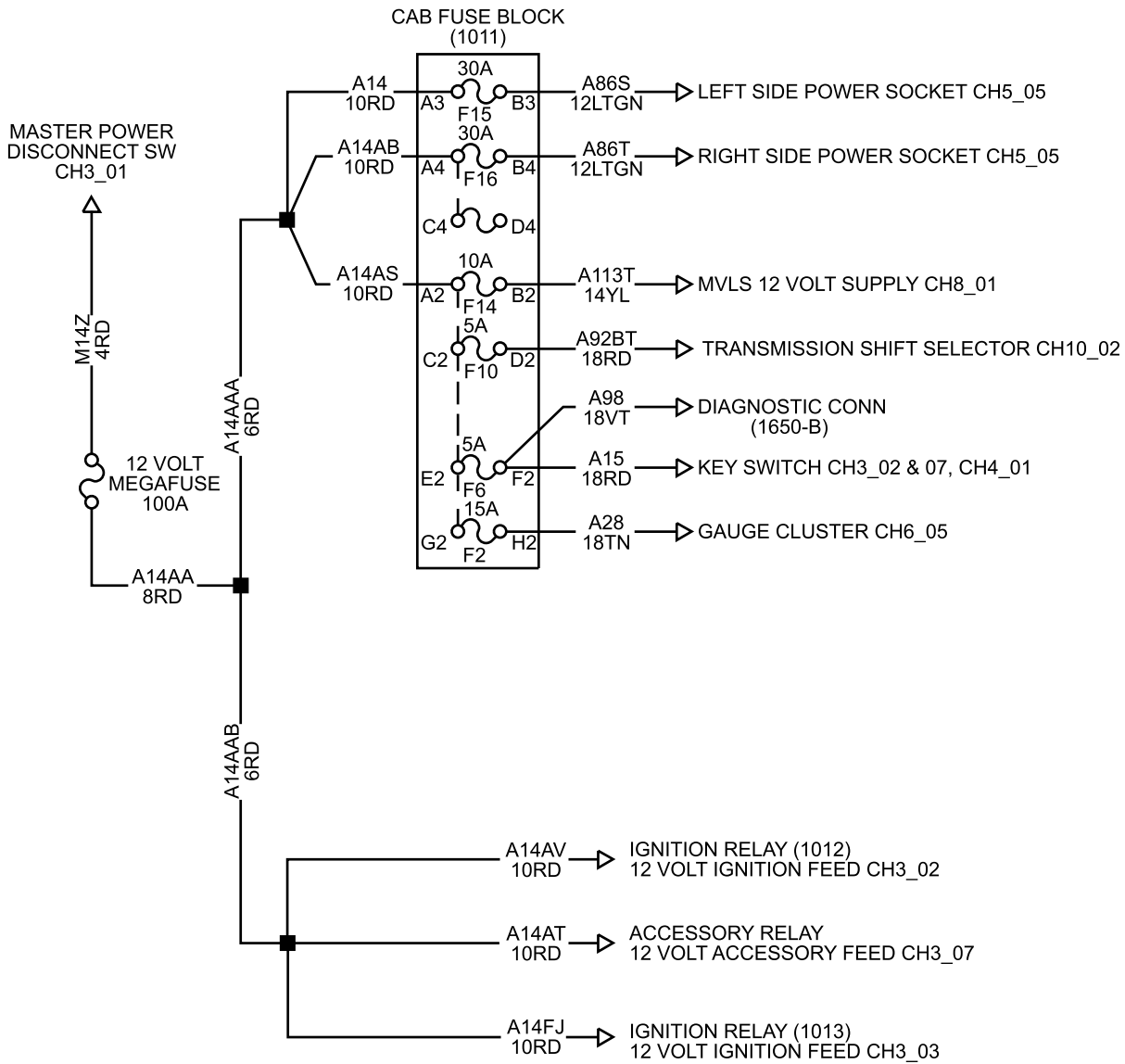

B235012358

Figure 8. CH3_05, 12V Battery Feed – Cabin.

ELECTRICAL SYSTEM SCHEMATICS - (CONTINUED)

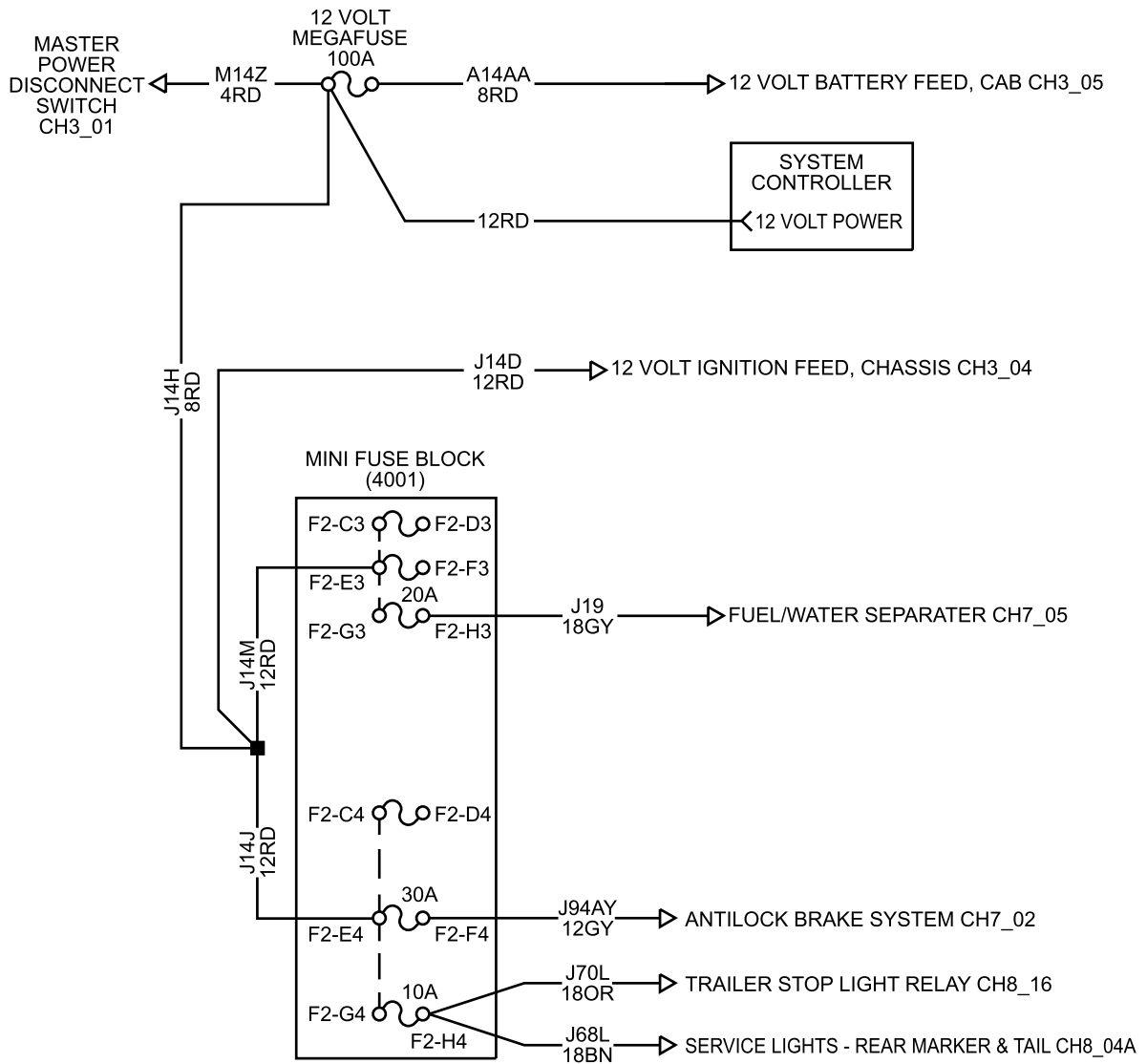

B235012359

Figure 9. CH3_06, 12V Battery Feed – Chassis.

ELECTRICAL SYSTEM SCHEMATICS - (CONTINUED)

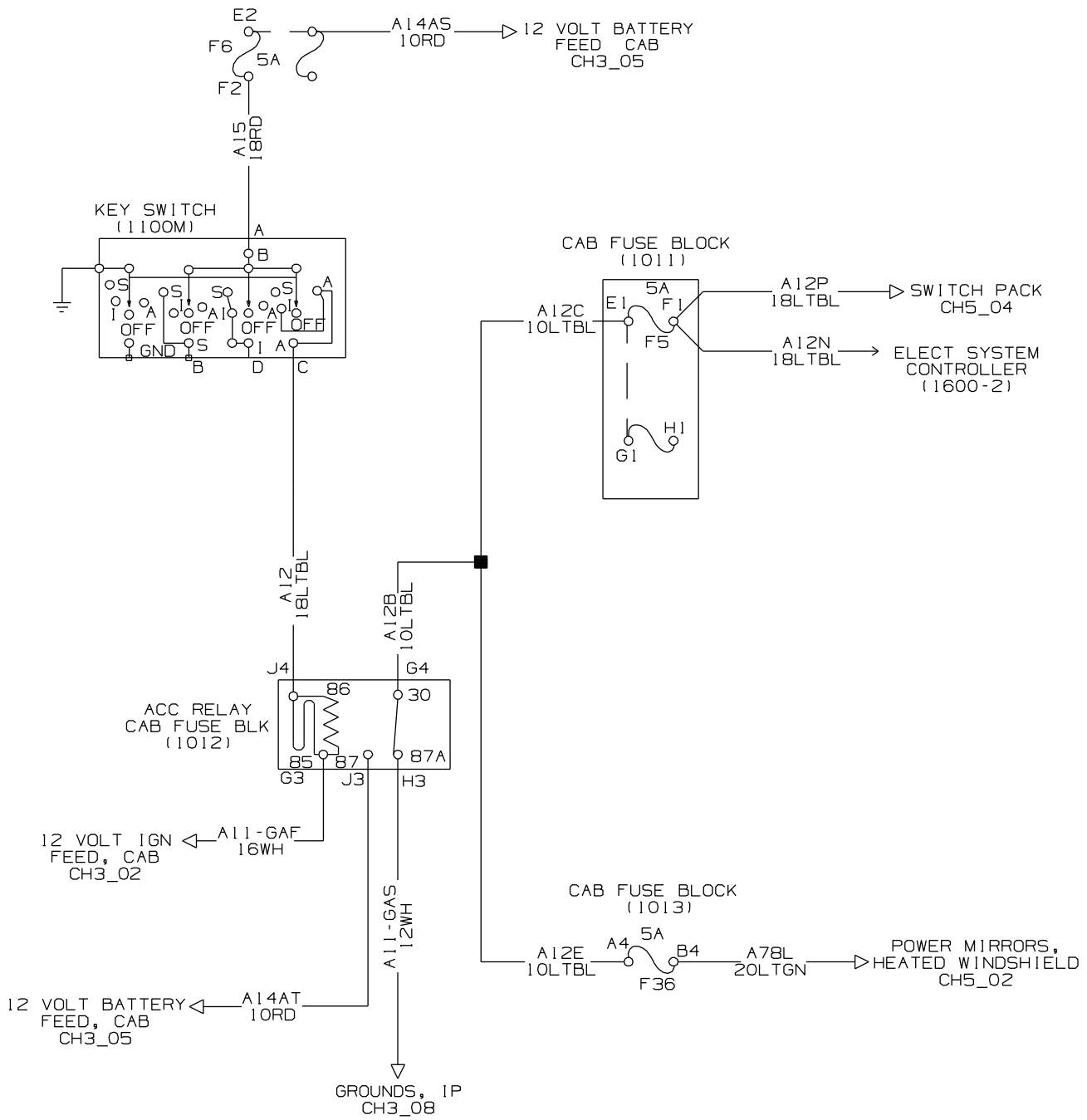

B235012360

Figure 10. CH3_07, 12V Accessory Feed.

ELECTRICAL SYSTEM SCHEMATICS - (CONTINUED)

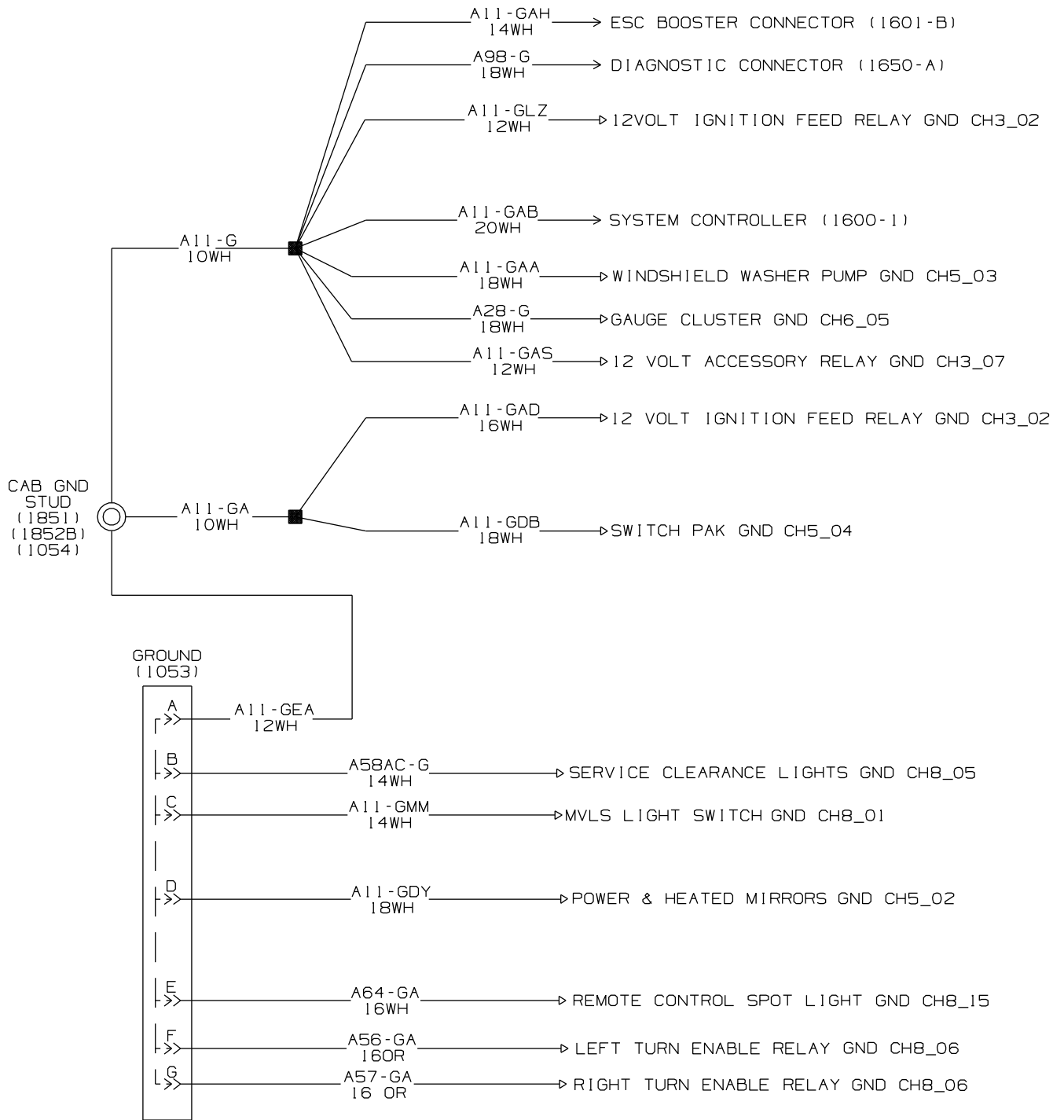

B235012361

Figure 11. CH3_08, Grounds – Instrument Panel (IP) (1 of 2).

ELECTRICAL SYSTEM SCHEMATICS - (CONTINUED)

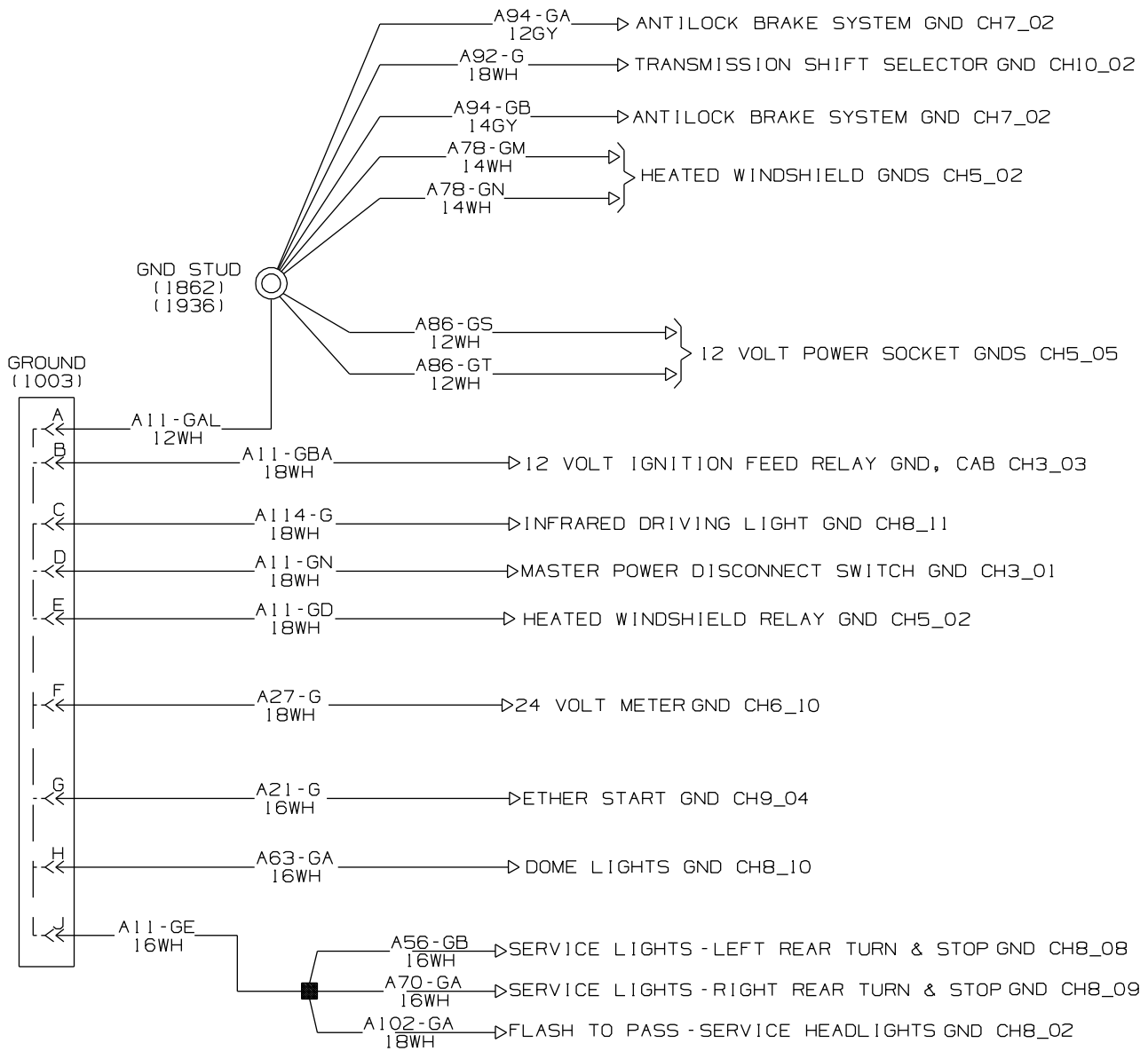

B235012362

Figure 12. CH3_09, Grounds – IP (2 of 2).

ELECTRICAL SYSTEM SCHEMATICS - (CONTINUED)

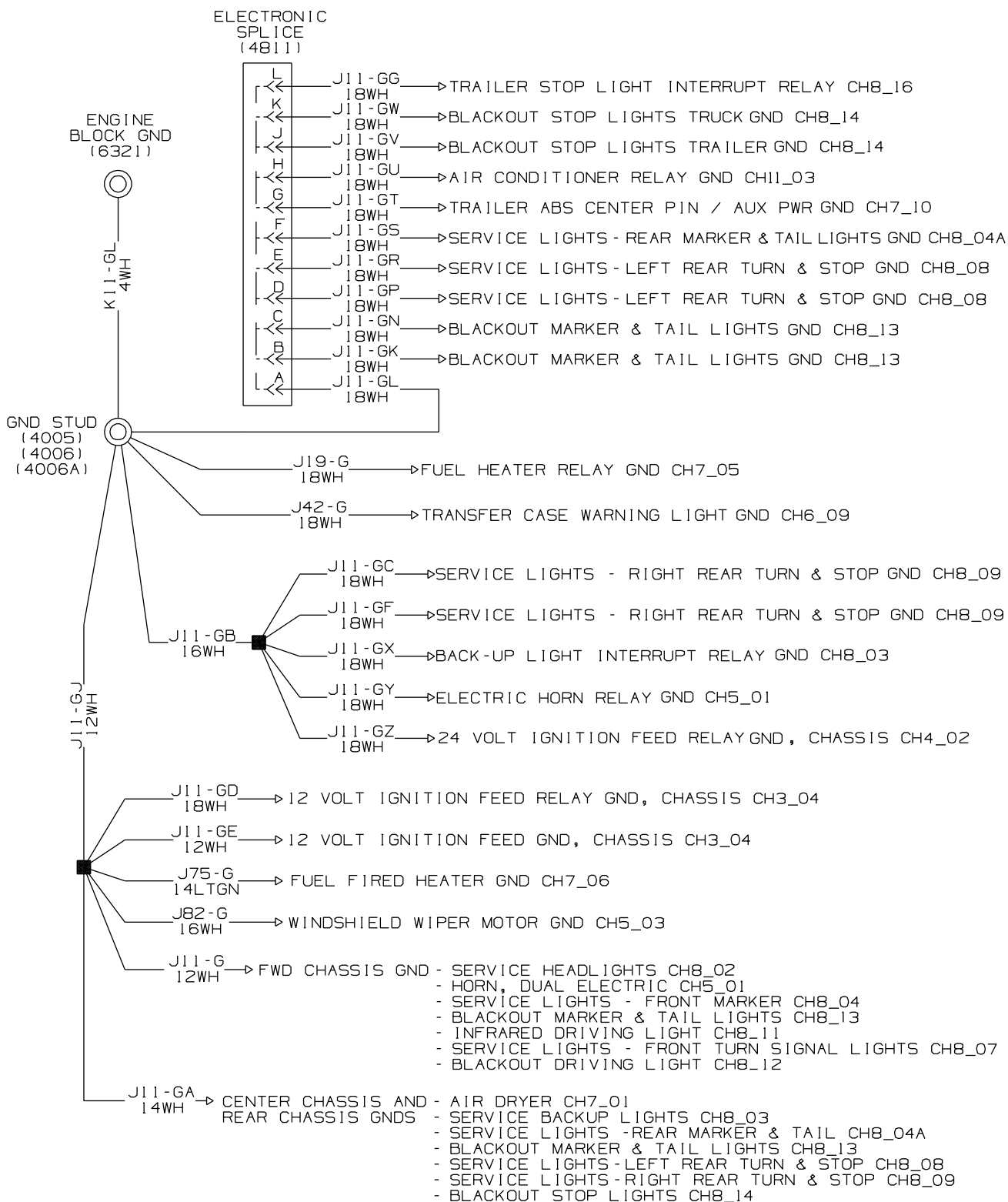
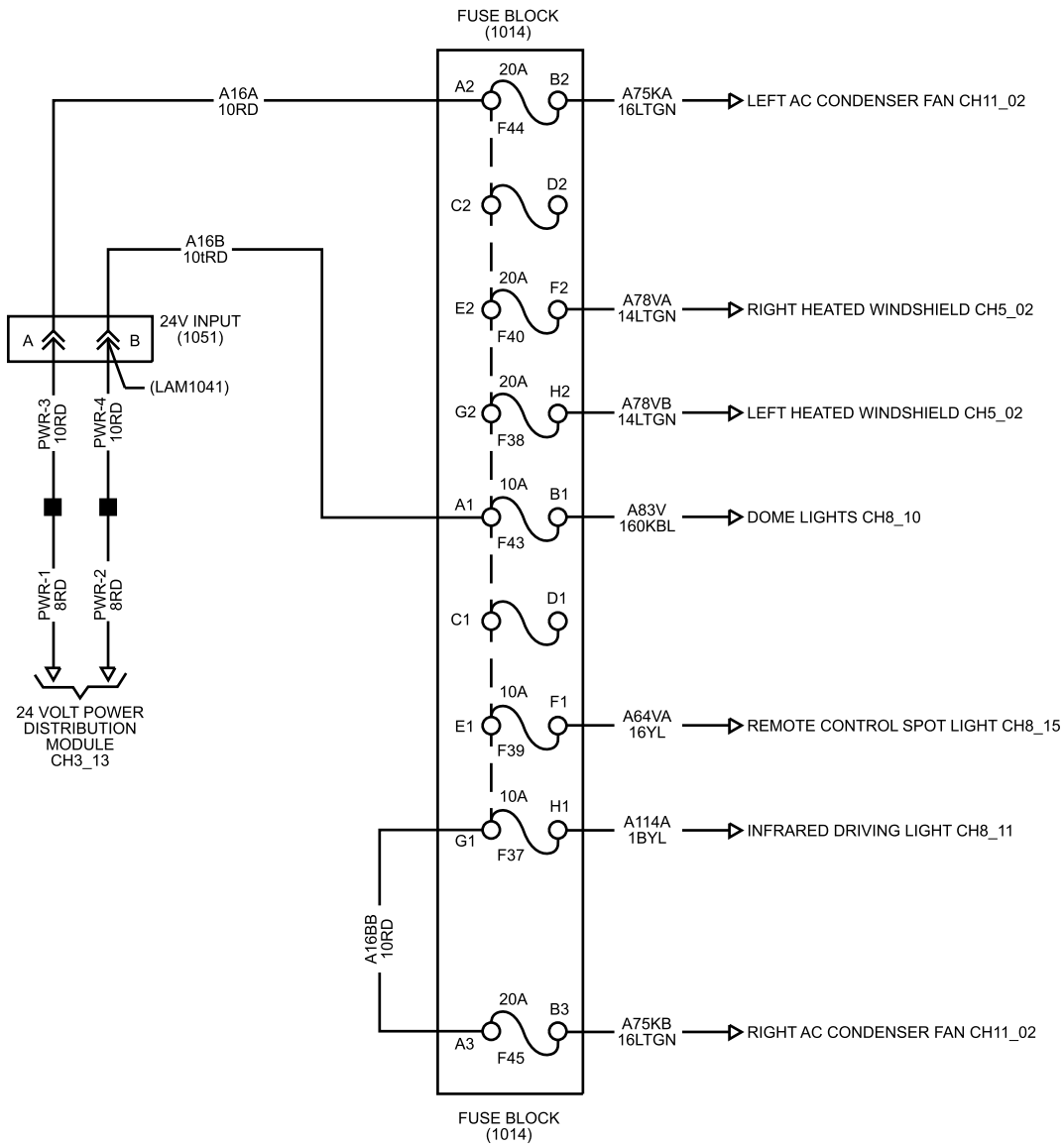

Figure 13. CH3_10, Grounds – Chassis.

ELECTRICAL SYSTEM SCHEMATICS - (CONTINUED)



B235012364

Figure 14. CH3_11, 24V Battery Feed – Cabin.

ELECTRICAL SYSTEM SCHEMATICS - (CONTINUED)

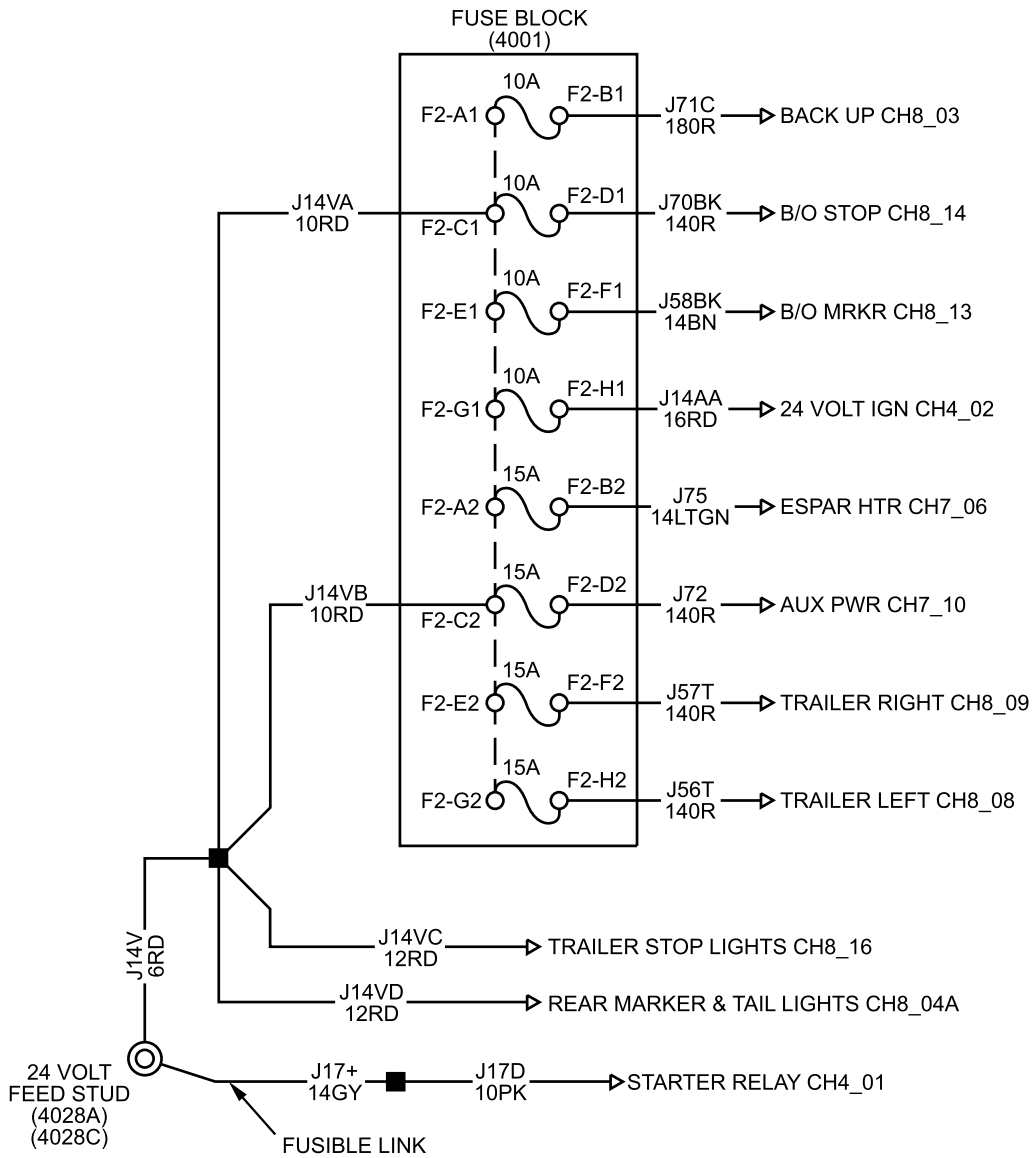

B235012365

Figure 15. CH3_12, 24V Battery Feed – Chassis.

ELECTRICAL SYSTEM SCHEMATICS - (CONTINUED)

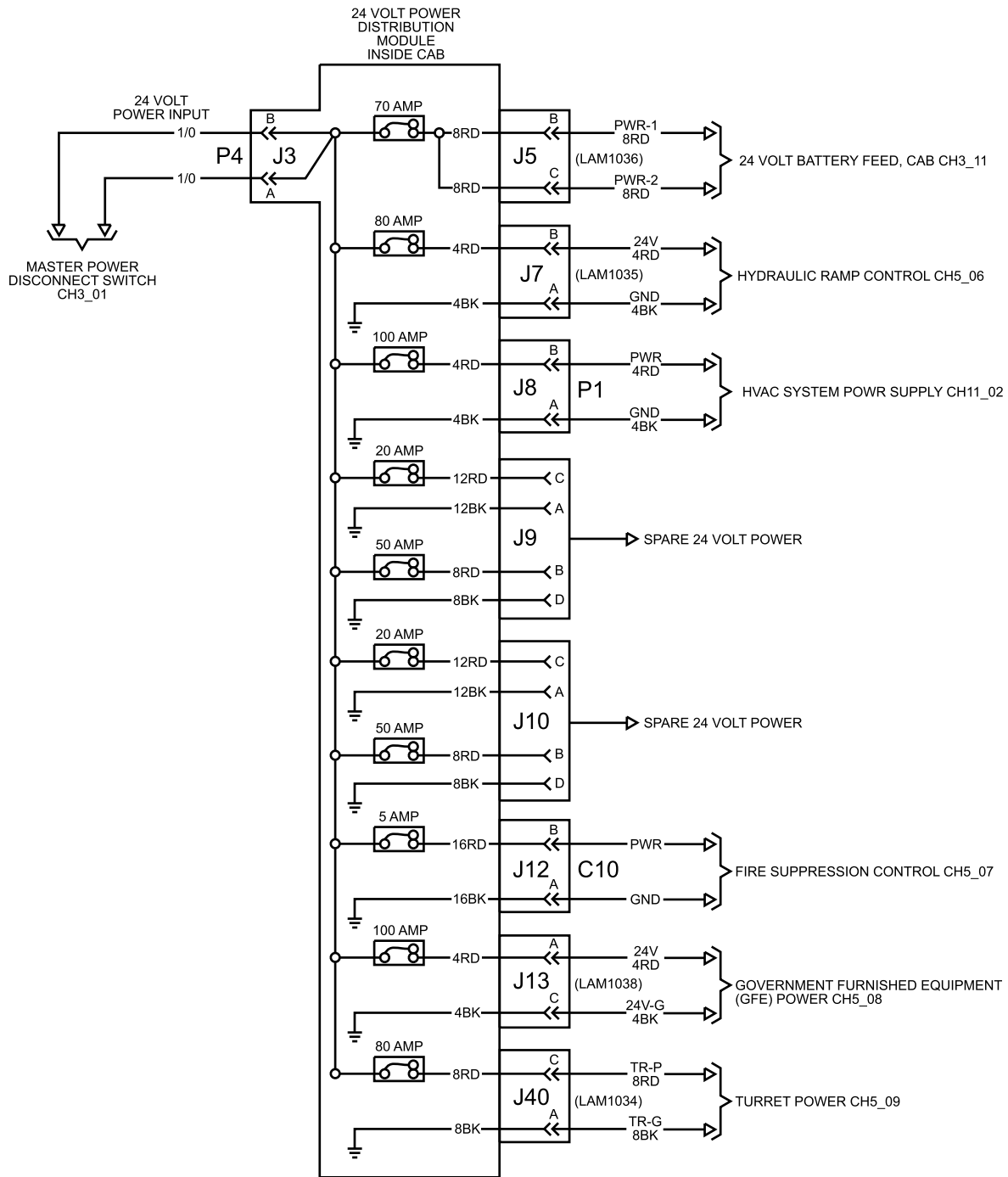

B235012366

Figure 16. CH3_13, 24V Power Distribution Module (PDM)..

ELECTRICAL SYSTEM SCHEMATICS - (CONTINUED)

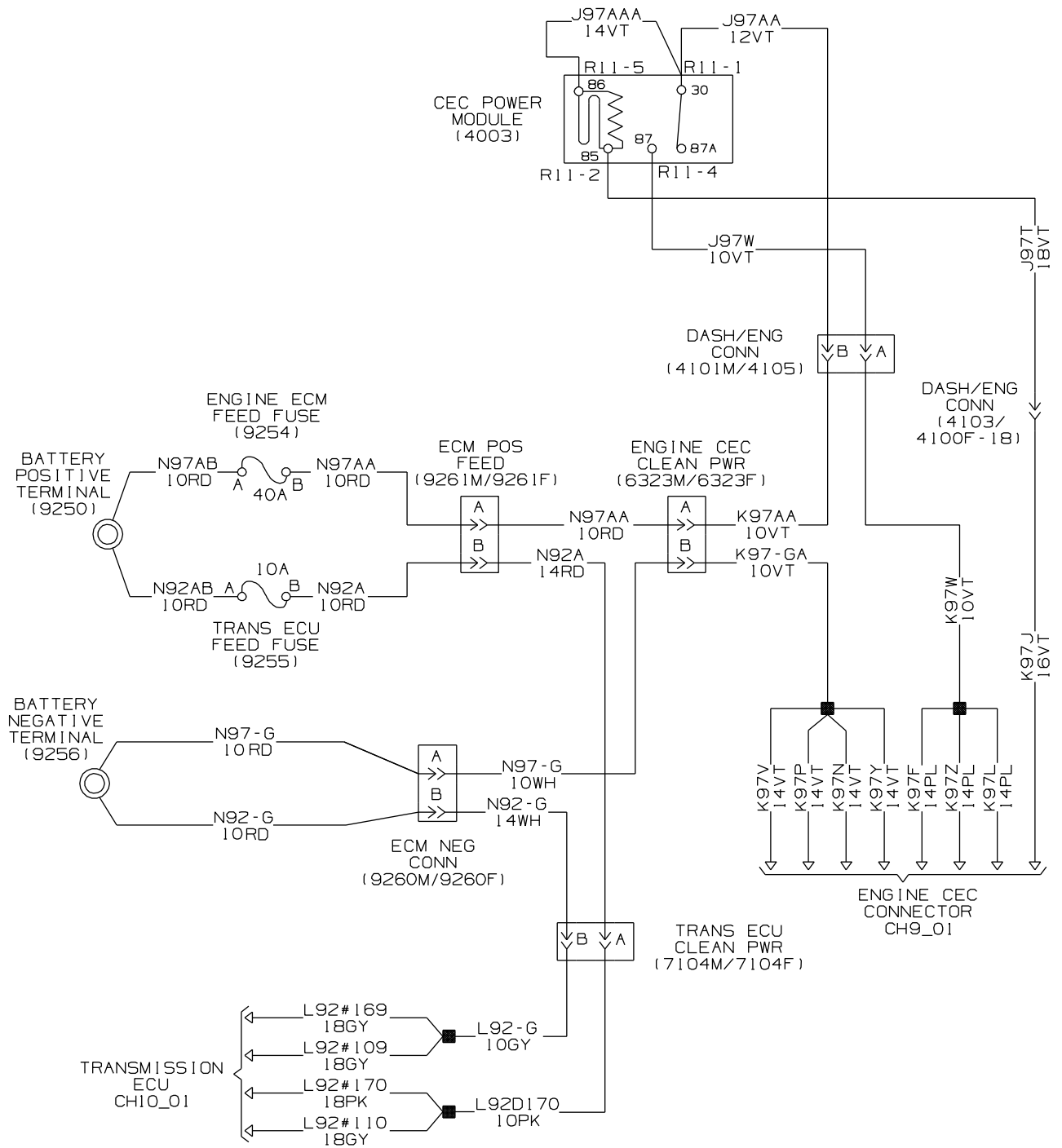

B235012367

Figure 17. CH3_14, CEC Engine and Transmission Clean Power and Ground.

ELECTRICAL SYSTEM SCHEMATICS - (CONTINUED)

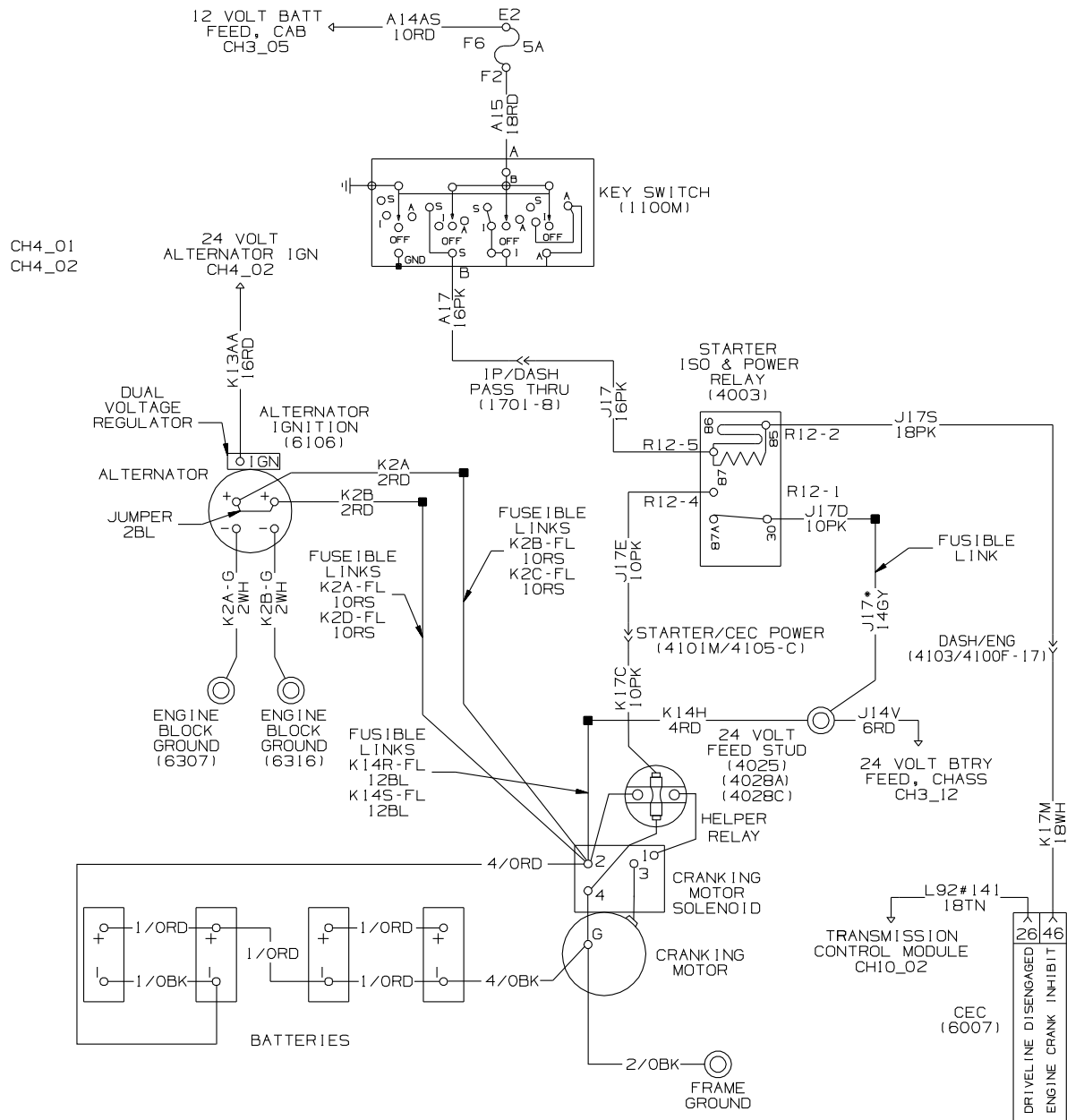

B235012368

Figure 18. CH4_01, 24V Cranking and Charging Circuits – I6 HEUI Engine.

ELECTRICAL SYSTEM SCHEMATICS - (CONTINUED)

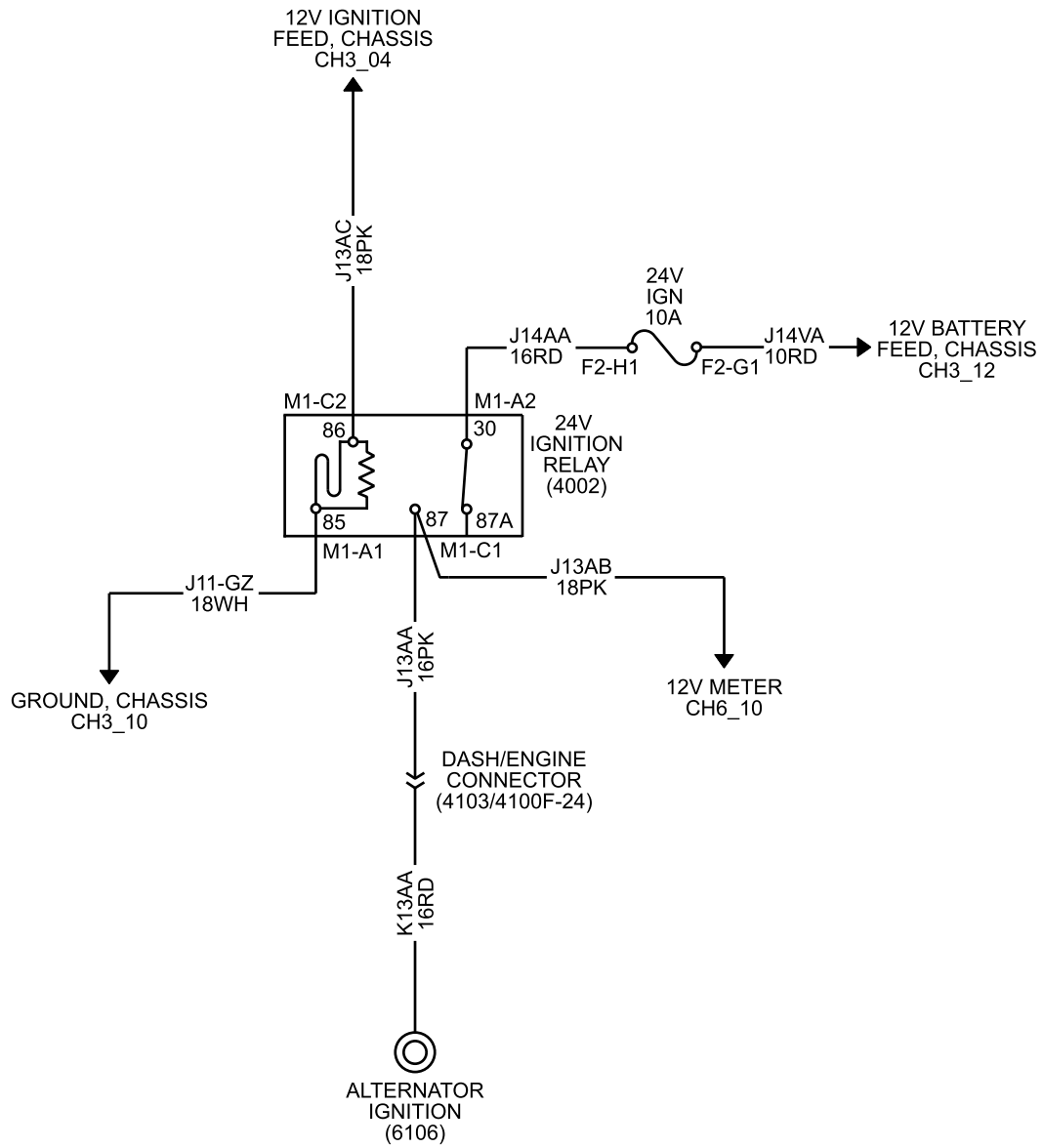

B235012369

Figure 19. CH4_02, 24V Alternator Ignition.

ELECTRICAL SYSTEM SCHEMATICS - (CONTINUED)

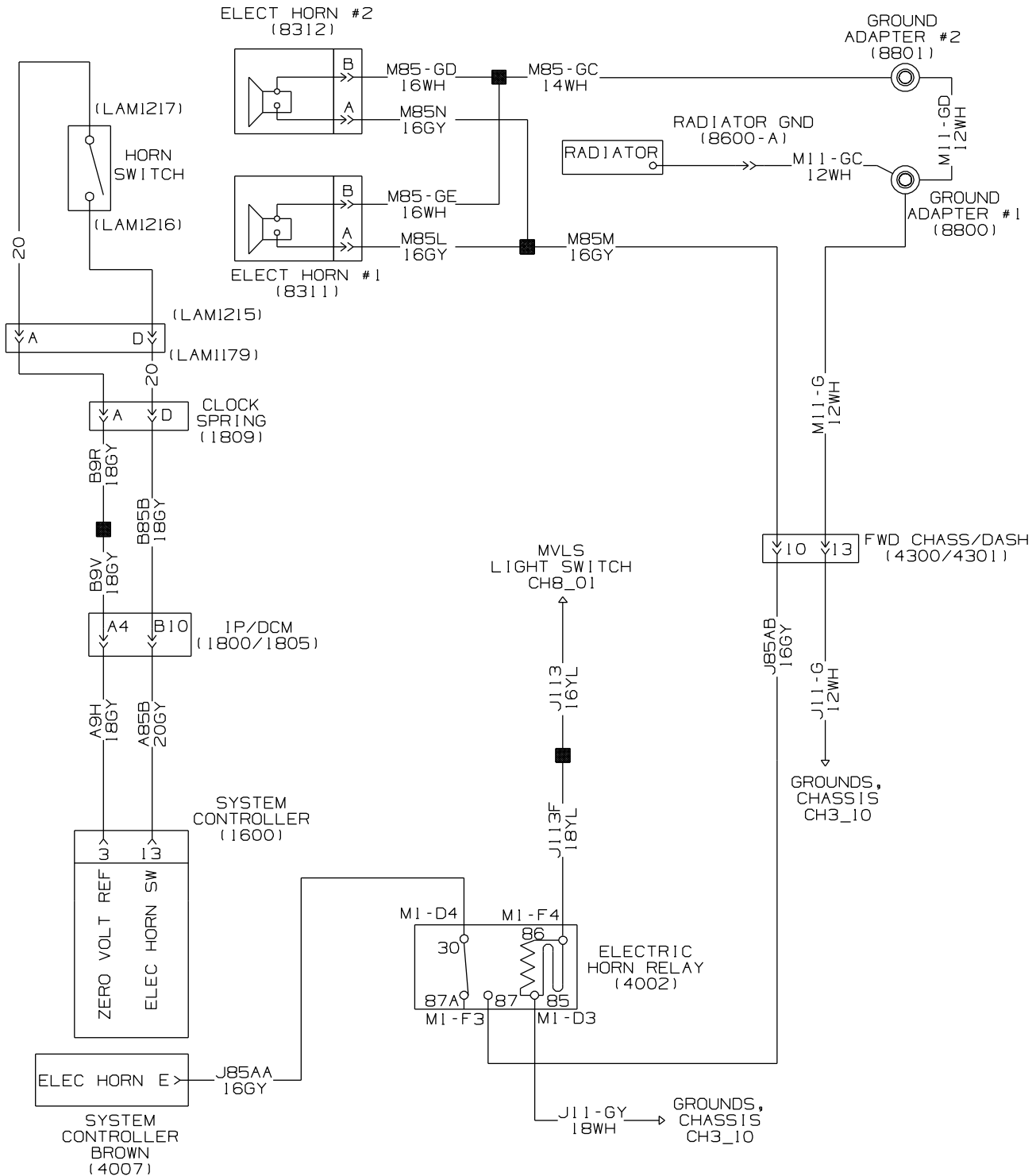

B235012370

Figure 20. CH5_01, Horn - Dual Electric.

ELECTRICAL SYSTEM SCHEMATICS - (CONTINUED)

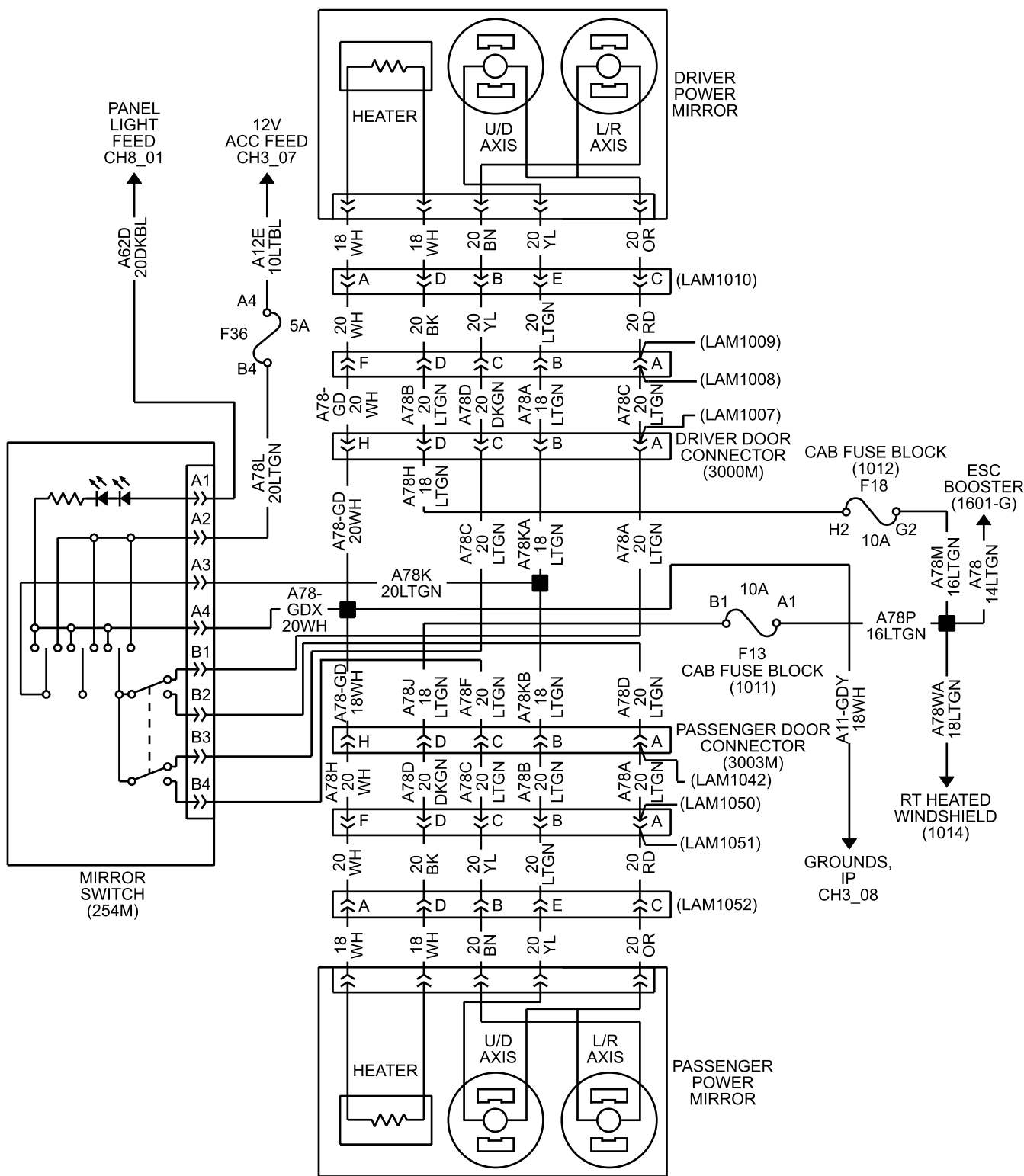

B235012371

Figure 21. CH5_02, Power and Heated Mirrors.

ELECTRICAL SYSTEM SCHEMATICS - (CONTINUED)

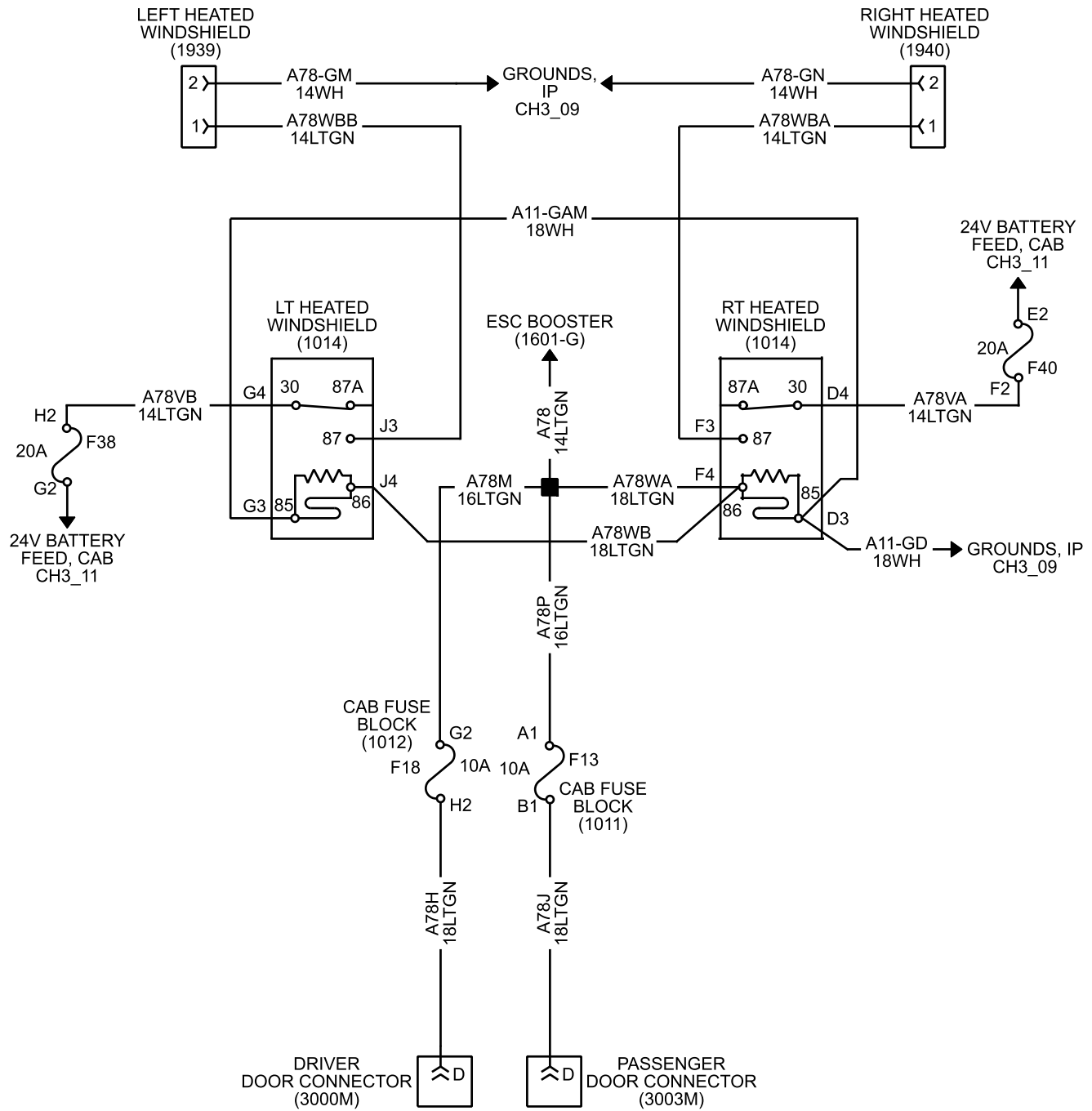

B235012372

Figure 22. CH5_02A, Heated Windshield.

ELECTRICAL SYSTEM SCHEMATICS - (CONTINUED)

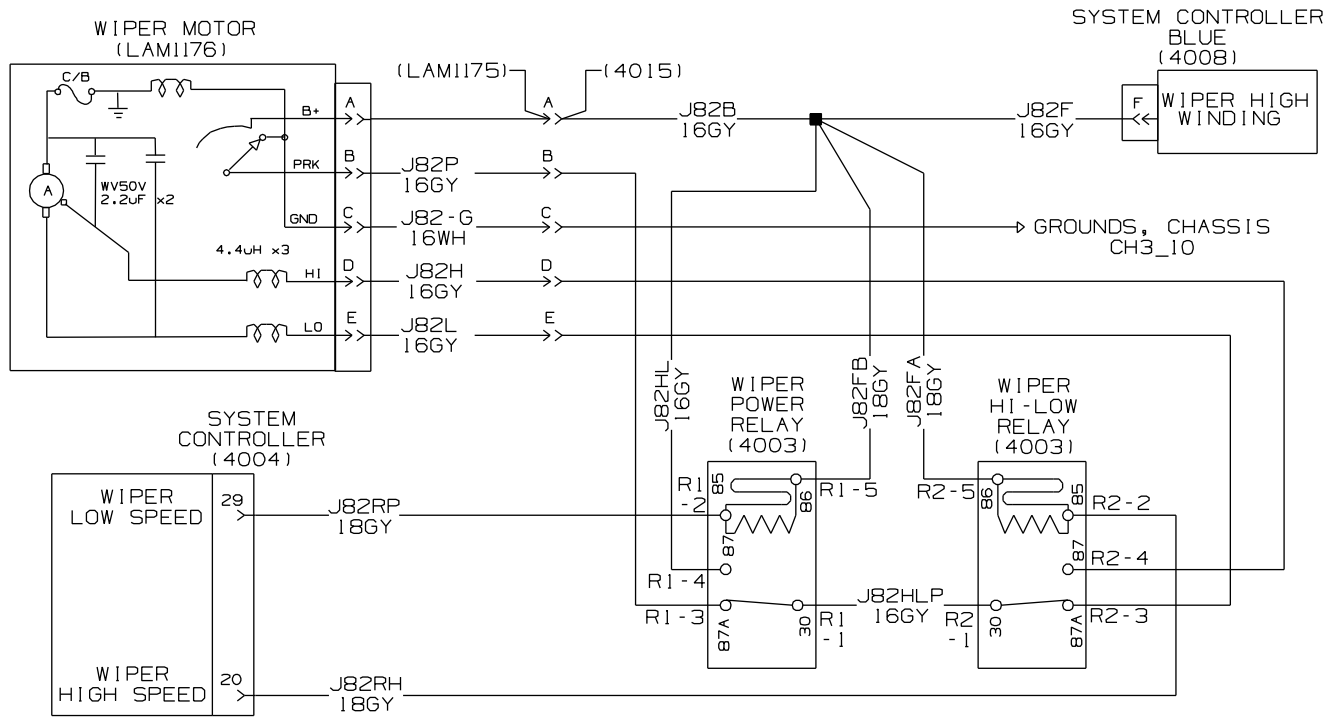

B235012373

Figure 23. CH5_03, Windshield Wiper Motor.

ELECTRICAL SYSTEM SCHEMATICS - (CONTINUED)

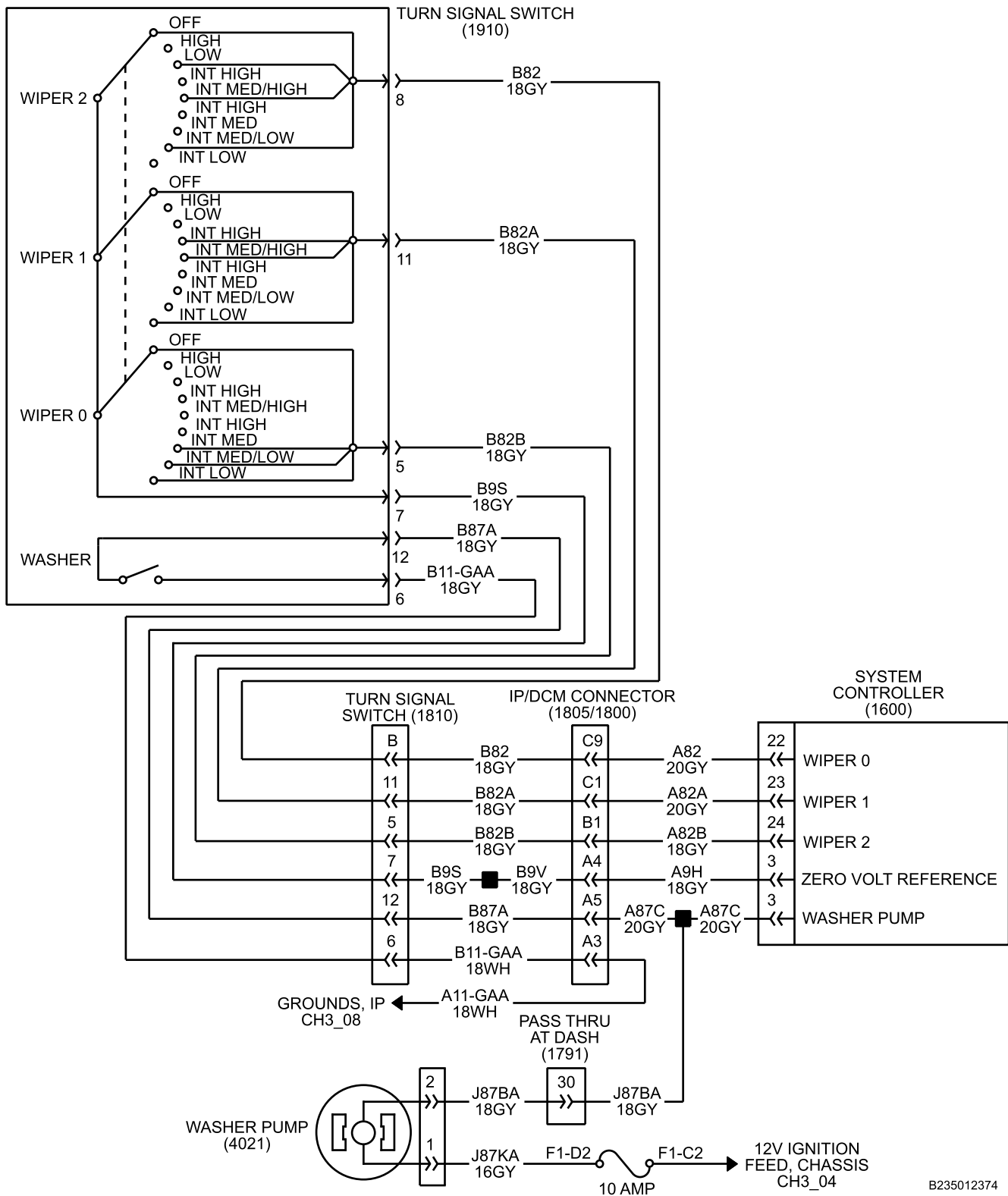
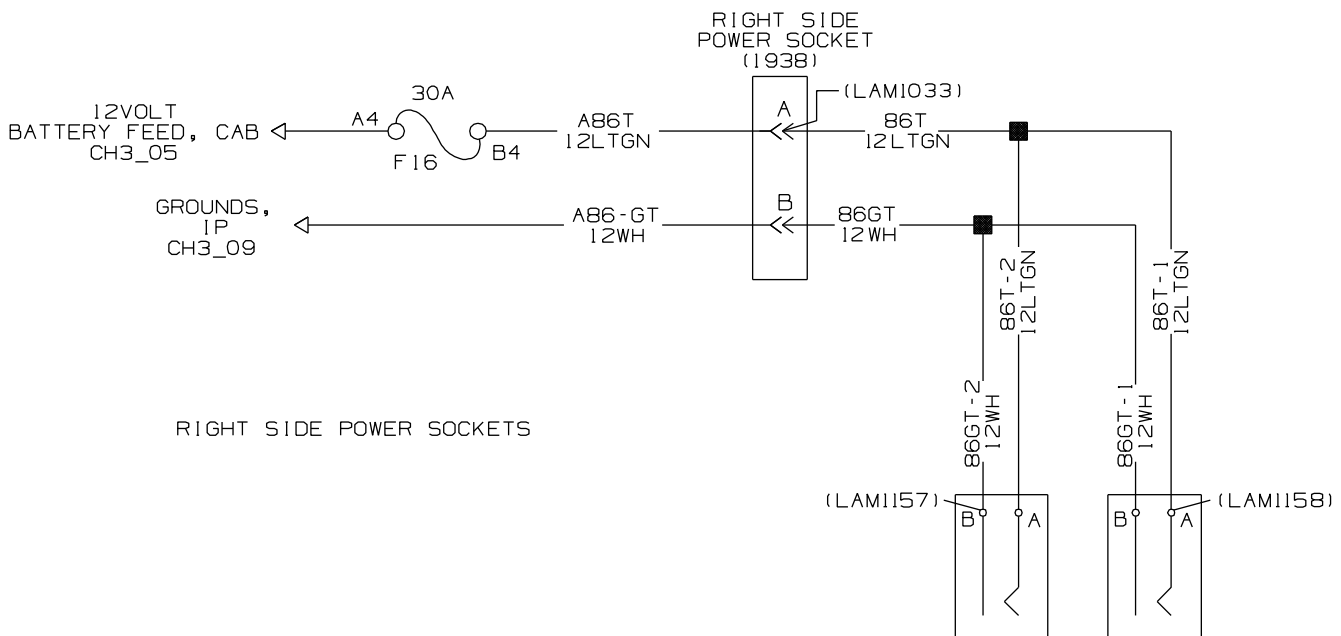
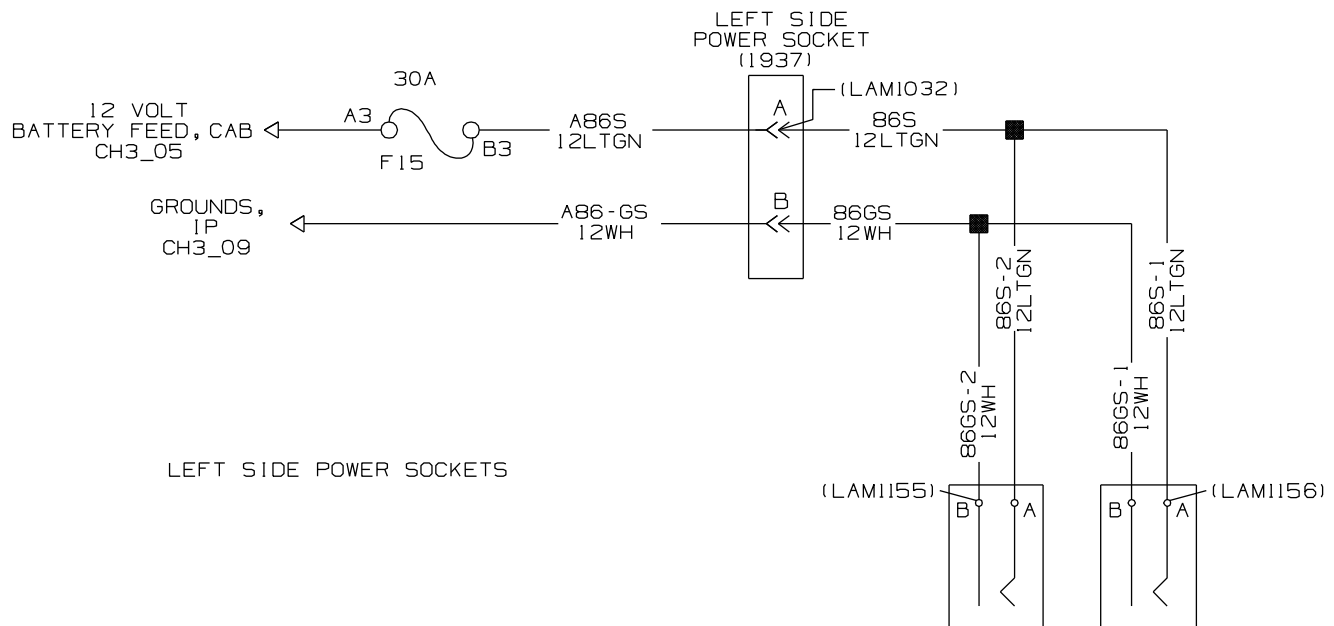

Figure 24. CH5_03A, Windshield Wiper Washer Pump.

B235012374

ELECTRICAL SYSTEM SCHEMATICS - (CONTINUED)



B235012376

Figure 26. CH5_05, 12V Power Sockets.

ELECTRICAL SYSTEM SCHEMATICS - (CONTINUED)

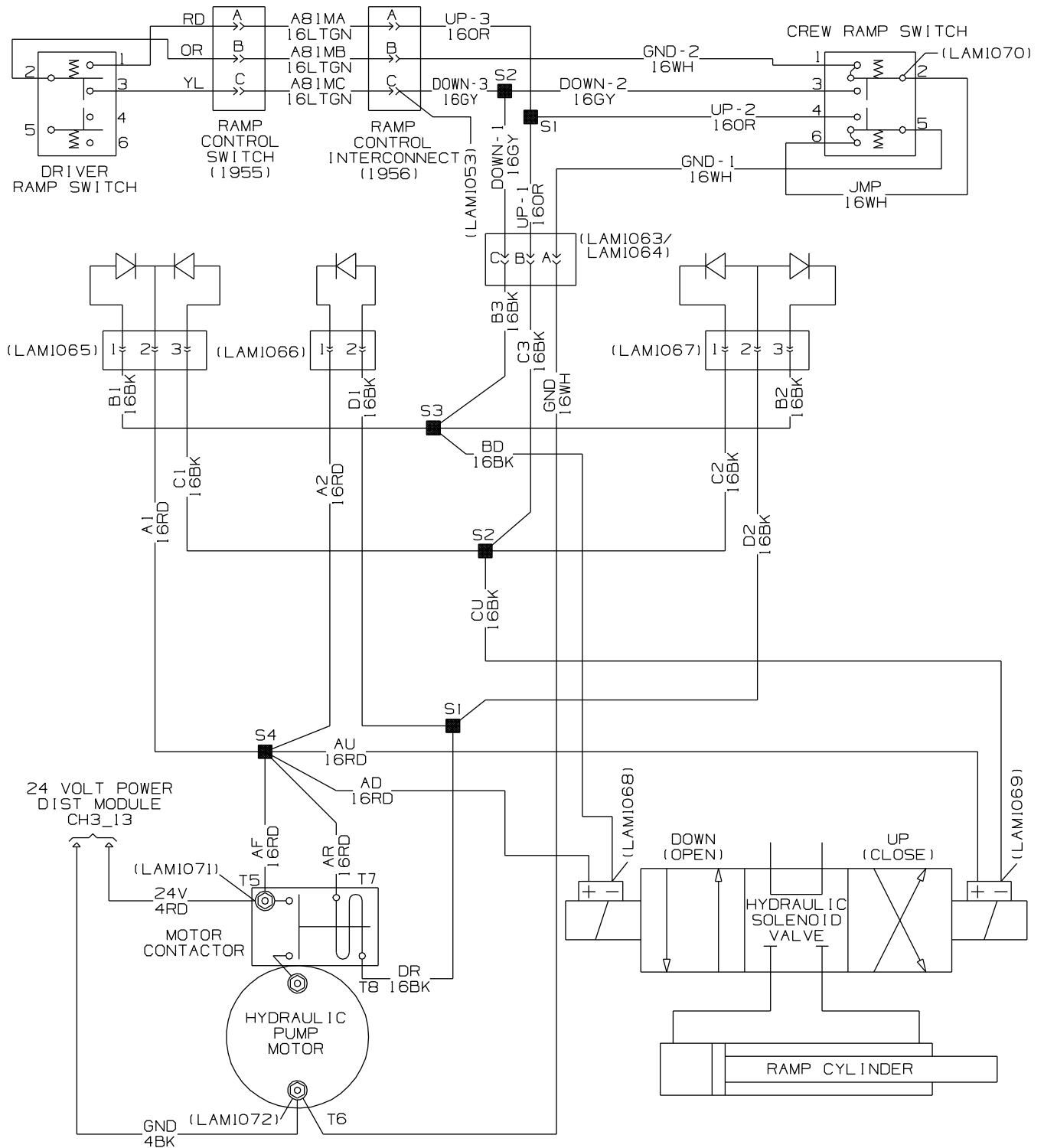

B235012377

Figure 27. CH5_06, Hydraulic Ramp Control – First Production.

ELECTRICAL SYSTEM SCHEMATICS - (CONTINUED)

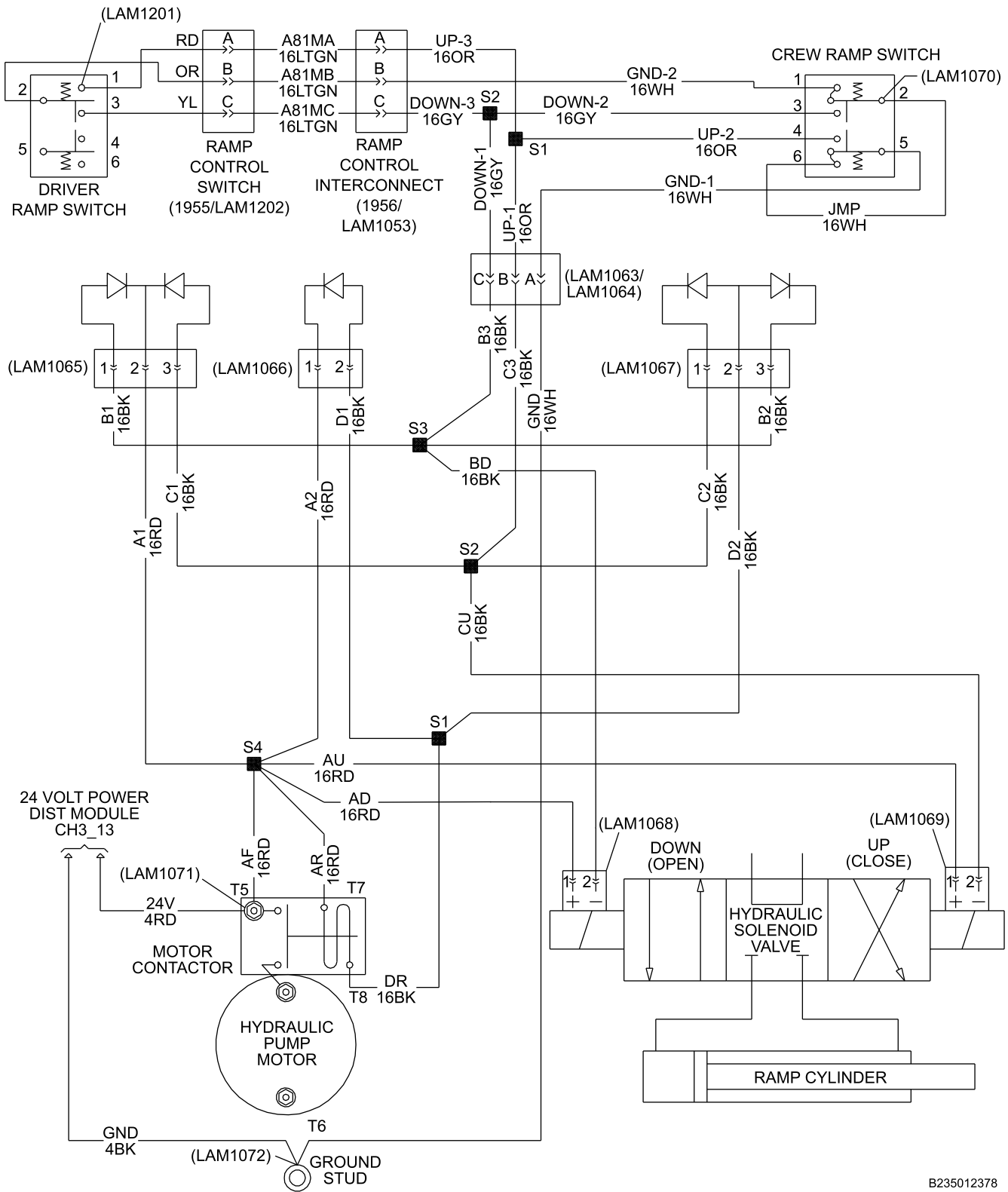

B235012378

Figure 28. CH5_06A, Hydraulic Ramp Control – Second Production.

ELECTRICAL SYSTEM SCHEMATICS - (CONTINUED)

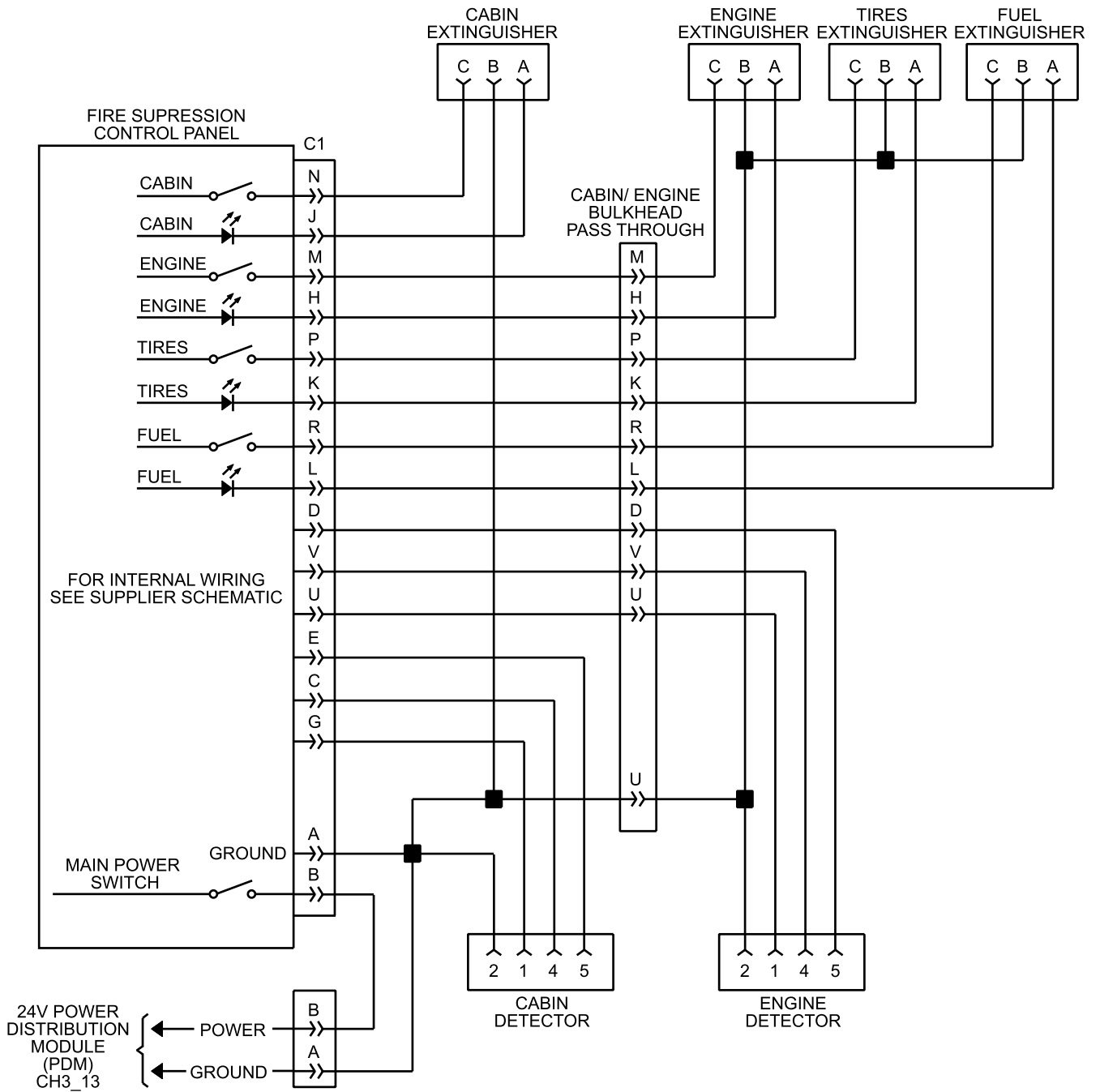

B235012379

Figure 29. CH5_07, Fire Suppression System (FSS) Control.

ELECTRICAL SYSTEM SCHEMATICS - (CONTINUED)

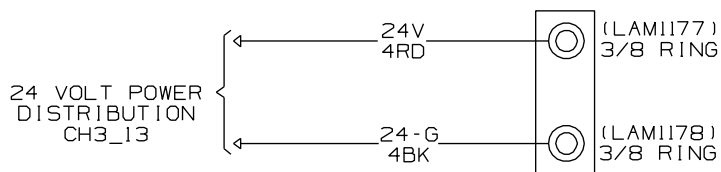

B235012380

Figure 30. CH5_08, Government Furnished Equipment (GFE) Power.

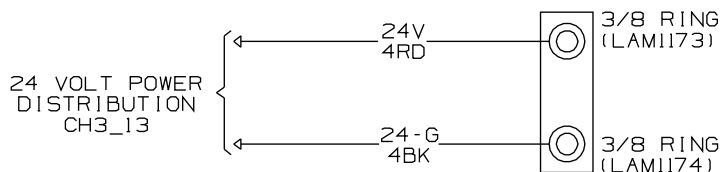

B235012381

Figure 31. CH5_09, Turret Power.

GAUGE	WARN LIGHT	SIGNAL PATH	SENSOR LOCATION
RPM (TACH)	NO	ENGINE CTRLR/DRIVE TRAIN J1939/CLUSTER	ENGINE
MPH/KPH (SPEEDO)	NO	ENGINE CTRLR/DRIVE TRAIN J1939/CLUSTER	TRANSMISSION
FUEL	YES	SYSTEM CTRLR/DRIVE TRAIN J1939/CLUSTER	FUEL TANK
VOLT	YES	SYSTEM CTRLR/DRIVE TRAIN J1939/CLUSTER	-
AIR 1 (PRESS)	YES	SYSTEM CTRLR/DRIVE TRAIN J1939/CLUSTER	INSIDE CAB-DASH PNL
AIR 2 (PRESS)	YES	SYSTEM CTRLR/DRIVE TRAIN J1939/CLUSTER	STEERING COL AREA
WATER (TEMP)	YES	ENGINE CTRLR/DRIVE TRAIN J1939/CLUSTER	ENGINE
OIL (PRES)	YES	ENGINE CTRLR/DRIVE TRAIN J1939/CLUSTER	ENGINE
TRANS (TEMP)	YES	SYSTEM CTRLR/DRIVE TRAIN J1939/CLUSTER	TRANSMISSION

NOTE: WARNING LIGHTS ARE PART OF THE GAUGES AND LOCATED IN THE GAUGE

B235001773

Figure 32. CH06_01, Instrument Panel Gauge List.

ELECTRICAL SYSTEM SCHEMATICS - (CONTINUED)

IP WARNING LIGHTS		
WARNING LIGHT TITLE	SIGNAL PATH	SENSOR LOCATION
RANGE INHIBITED	XMSN CTRLR/DRIVE TRAIN J1939/CLUSTER	
ENGINE (YELLOW LED)	ENGINE CTRLR/DRIVE TRAIN J1939/CLUSTER	
ENGINE (RED LED)	ENGINE CTRLR/DRIVE TRAIN J1939/CLUSTER	
CHECK XMSN	XMSN CTRLR/DRIVE TRAIN J1939/CLUSTER	
TRAILER ABS	TRLR ABS CTRLR/DRIVE TRAIN J1939/CLUSTER	
(LEFT TURN)	SYSTEM CTRLR/DRIVE TRAIN J1939/CLUSTER	TURN SIG SW
WATER IN FUEL	SYSTEM CTRLR/DRIVE TRAIN J1939/CLUSTER	FUEL FILTER
COOLANT LEVEL	ENGINE CTRLR/DRIVE TRAIN J1939/CLUSTER	SURGE TANK
PARK (P)	SYSTEM CTRLR/DRIVE TRAIN J1939/CLUSTER	SWITCH
ABS	TRUCK CTRLR/DRIVE TRAIN J1939/CLUSTER	
(RIGHT TURN)	SYSTEM CTRLR/DRIVE TRAIN J1939/CLUSTER	
FASTEN BELTS	SYSTEM CTRLR/DRIVE TRAIN J1939/CLUSTER	
(HIGH BEAM IND)	SYSTEM CTRLR/DRIVE TRAIN J1939/CLUSTER	

B235001774

Figure 33. CH06_02, Instrument Panel Warning Light List.

THE FOLLOWING WARNING LIGHTS ARE CONTROLLED BY THE ENGINE, TRANSMISSION, OR ABS CONTROLLER OVER THE DATA BUS AND DO NOT HAVE INDEPENDENT CIRCUITRY THAT CAN BE OR NEEDS TO BE SHOWN:

- ENGINE (YELLOW LENS)
- ENGINE (RED LENS)
- CHECK TRANS
- TRAILER ABS
- CHECK ELECTR SYS
- ABS
- RANGE INHIBITED

B235001801

Figure 34. CH06_03, Warning Lights Controlled by Engine, Transmission, and Antilock Brake System (ABS) Controller.

ELECTRICAL SYSTEM SCHEMATICS - (CONTINUED)

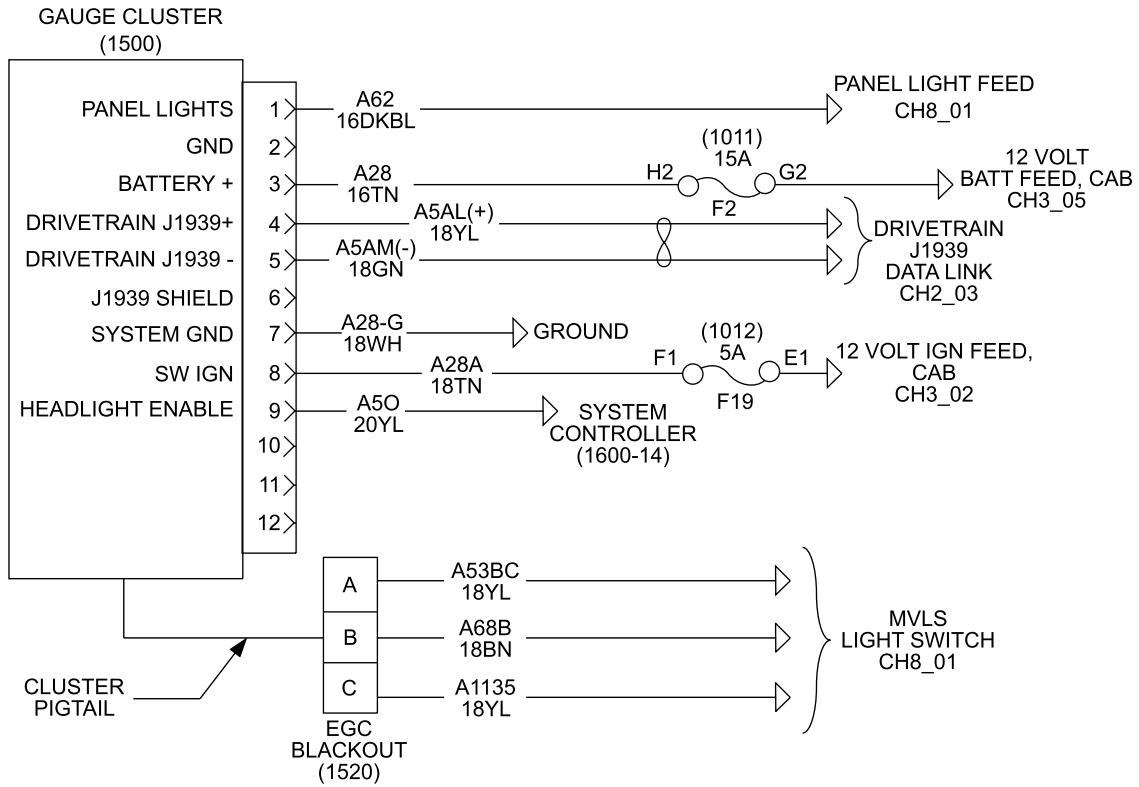

B235012382

Figure 35. CH6_05, Gauge Cluster.

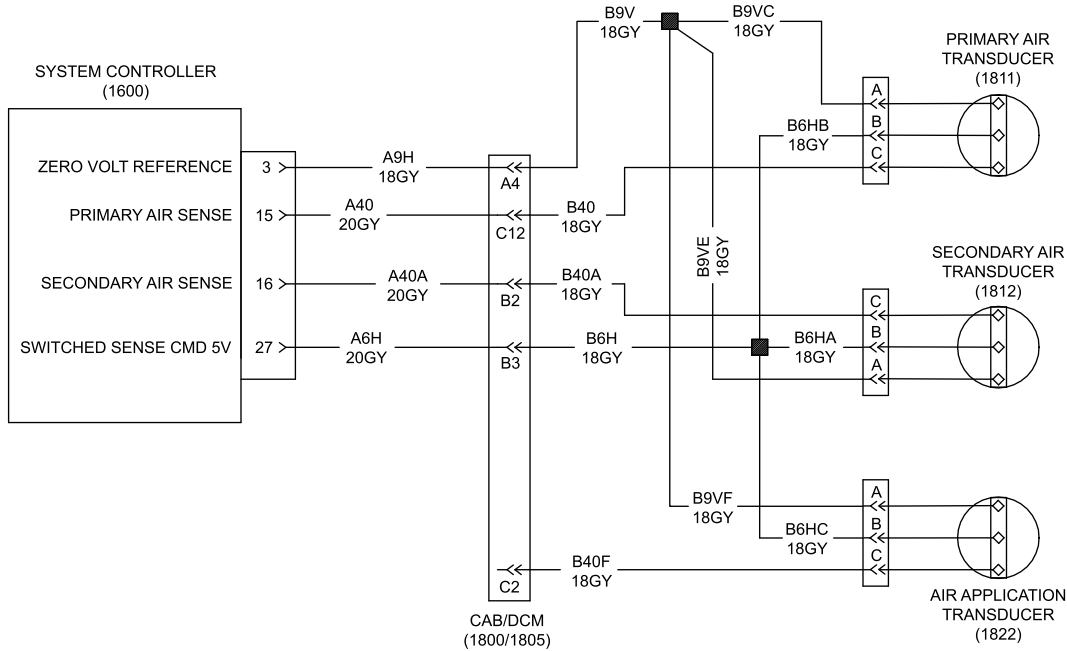

B235012383

Figure 36. CH6_06, Air Pressure Input Circuits.

ELECTRICAL SYSTEM SCHEMATICS - (CONTINUED)

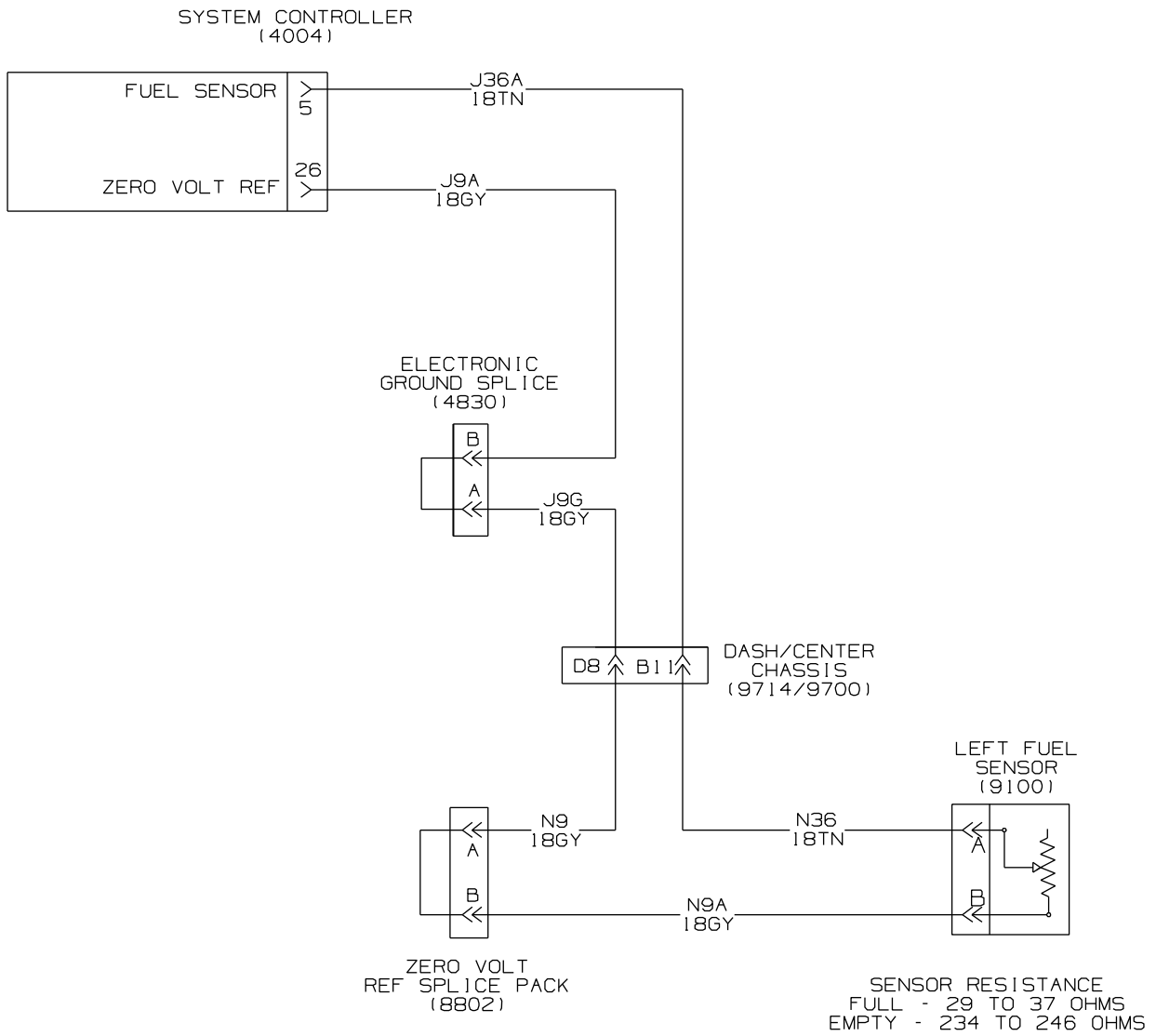

B235001745

Figure 37. CH6_07, Fuel Gauge Input Circuit.

ELECTRICAL SYSTEM SCHEMATICS - (CONTINUED)

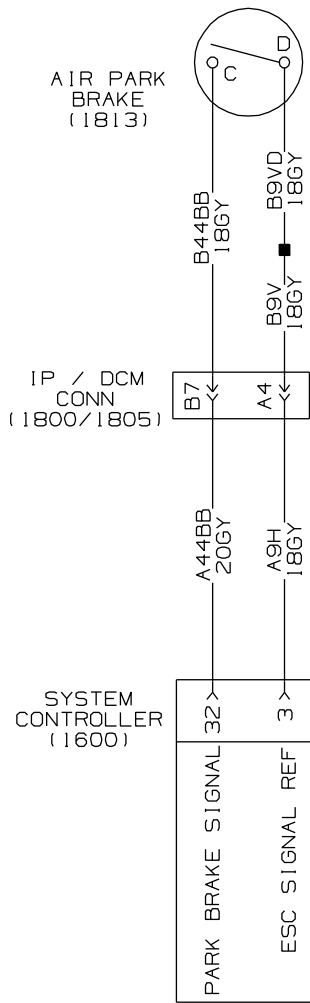

B235001726

Figure 38. CH6_08, Air Park Brake Warning Light.

ELECTRICAL SYSTEM SCHEMATICS - (CONTINUED)

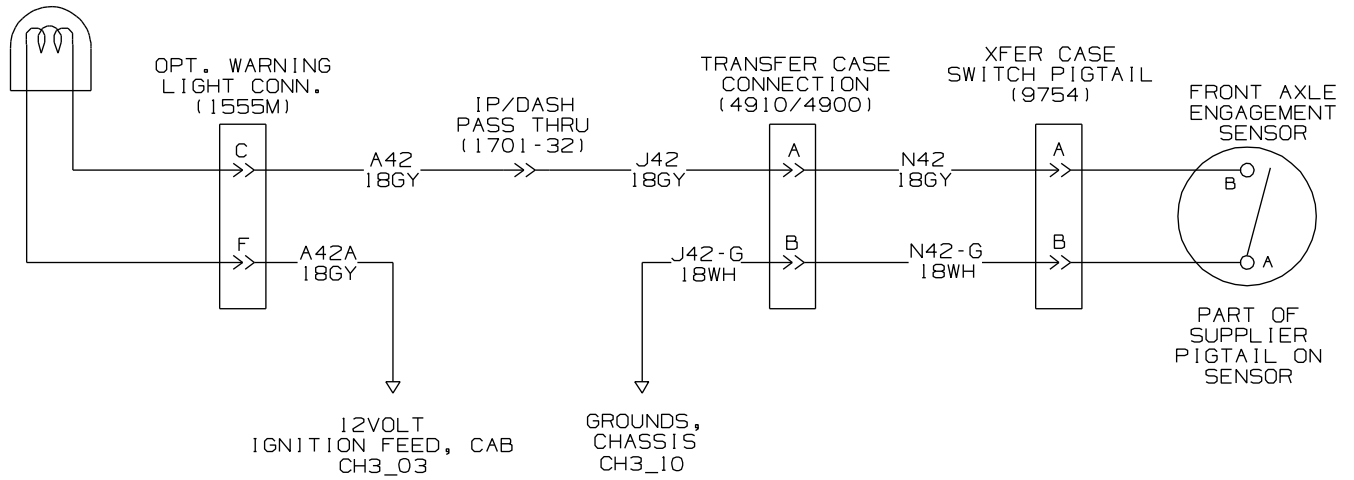

B235012386

Figure 39. CH6_09, Warning Light – Transfer Case.

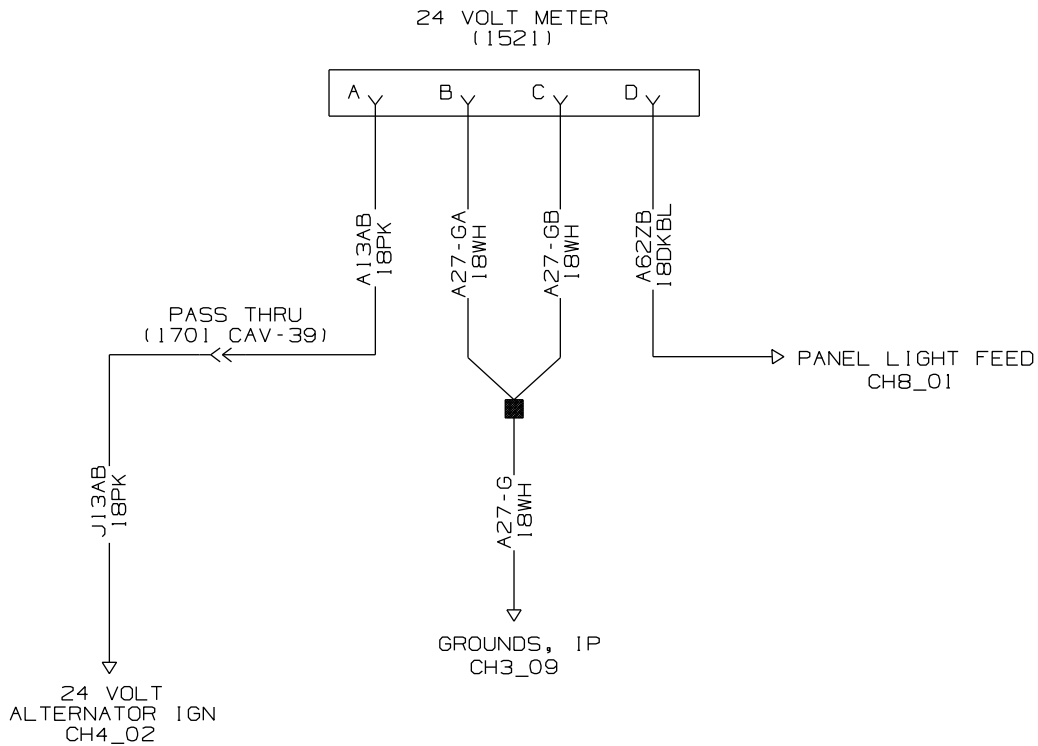

B235012387

Figure 40. CH6_10, 24V Meter.

ELECTRICAL SYSTEM SCHEMATICS - (CONTINUED)

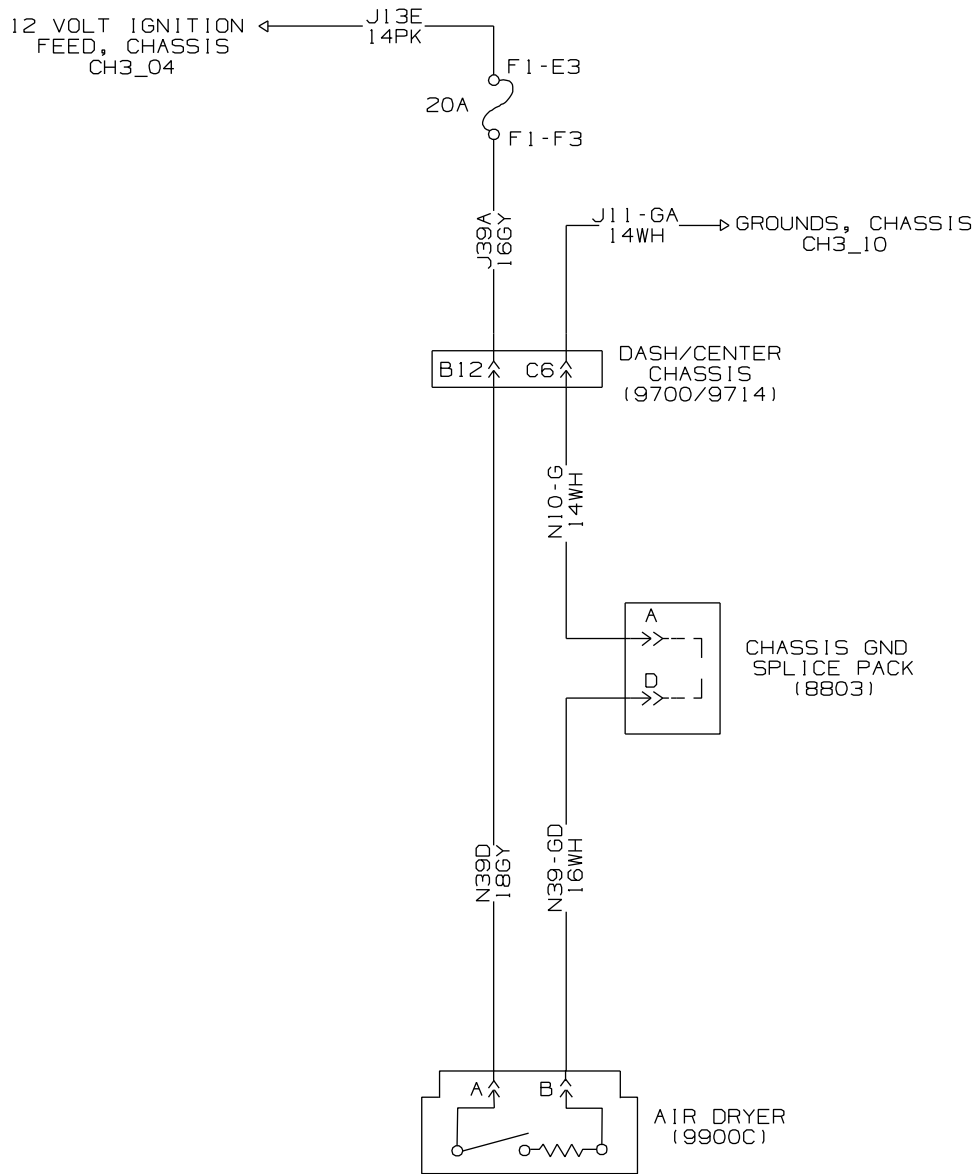

B235012388

Figure 41. CH7_01, Air Dryer.

ELECTRICAL SYSTEM SCHEMATICS - (CONTINUED)

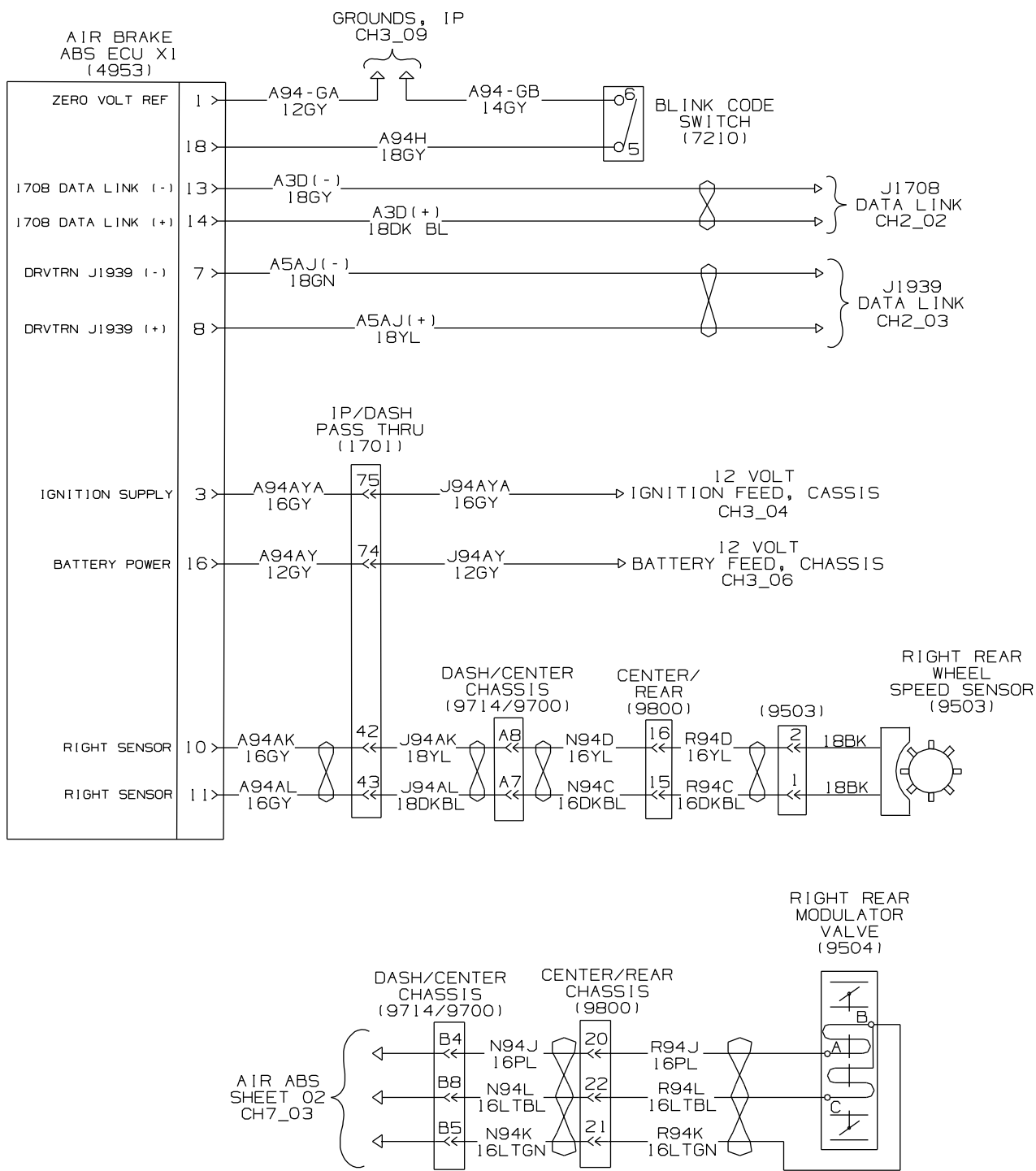

B235012389

Figure 42. CH7_02, Air – Antilock Brake System (1 of 2).

ELECTRICAL SYSTEM SCHEMATICS - (CONTINUED)

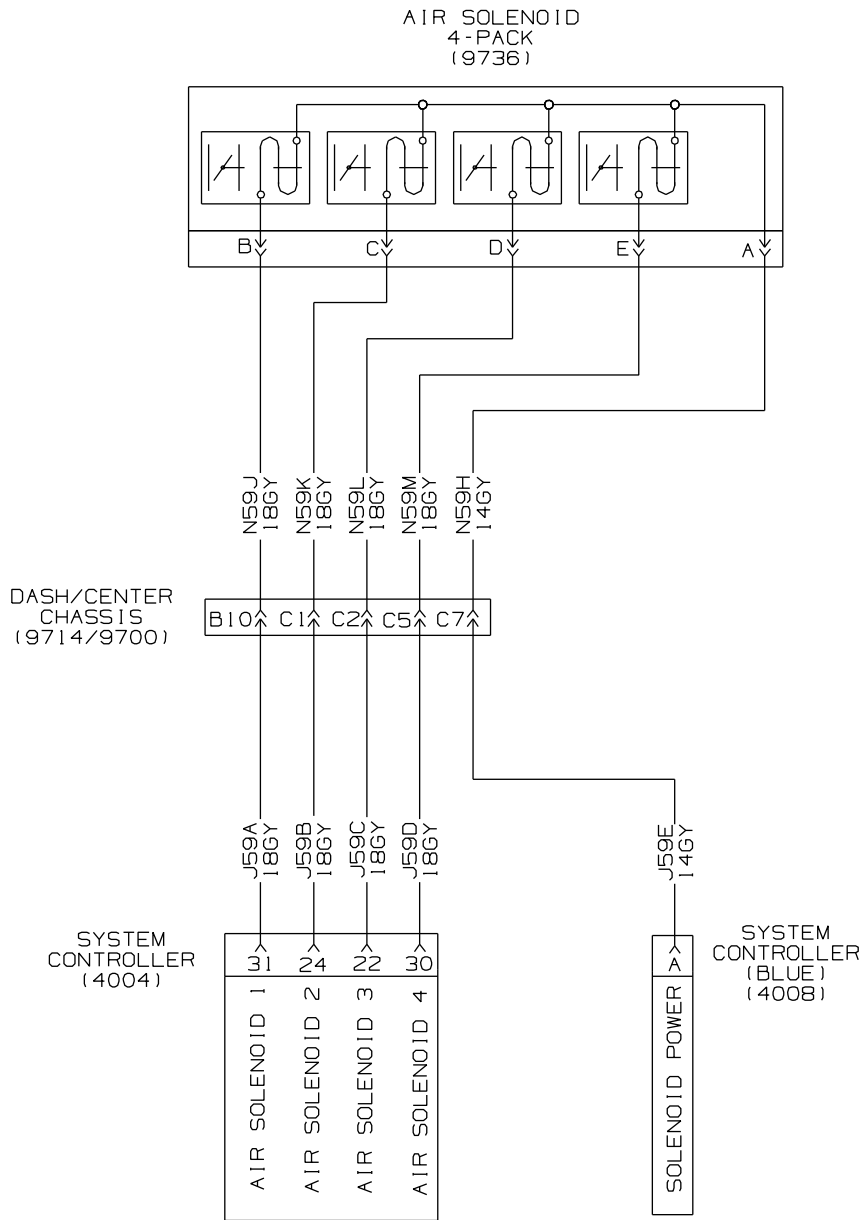

B235001722

Figure 44. CH7_04, Air Solenoid 4-Way Pack.

ELECTRICAL SYSTEM SCHEMATICS - (CONTINUED)

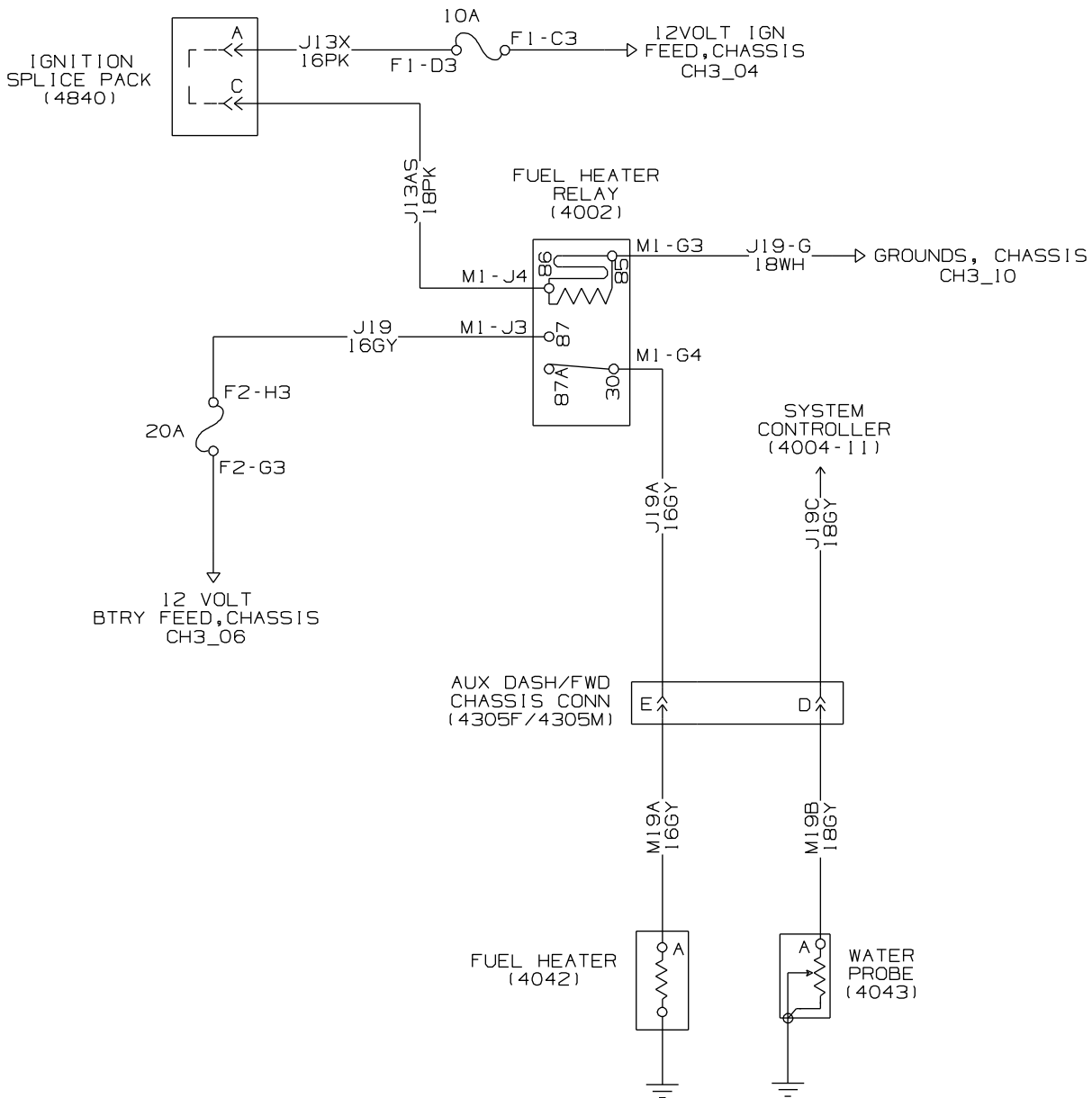

B235012392

Figure 45. CH7_05, Fuel Water Separator with 12V Fuel Pre-Heater and Water Probe.

ELECTRICAL SYSTEM SCHEMATICS - (CONTINUED)

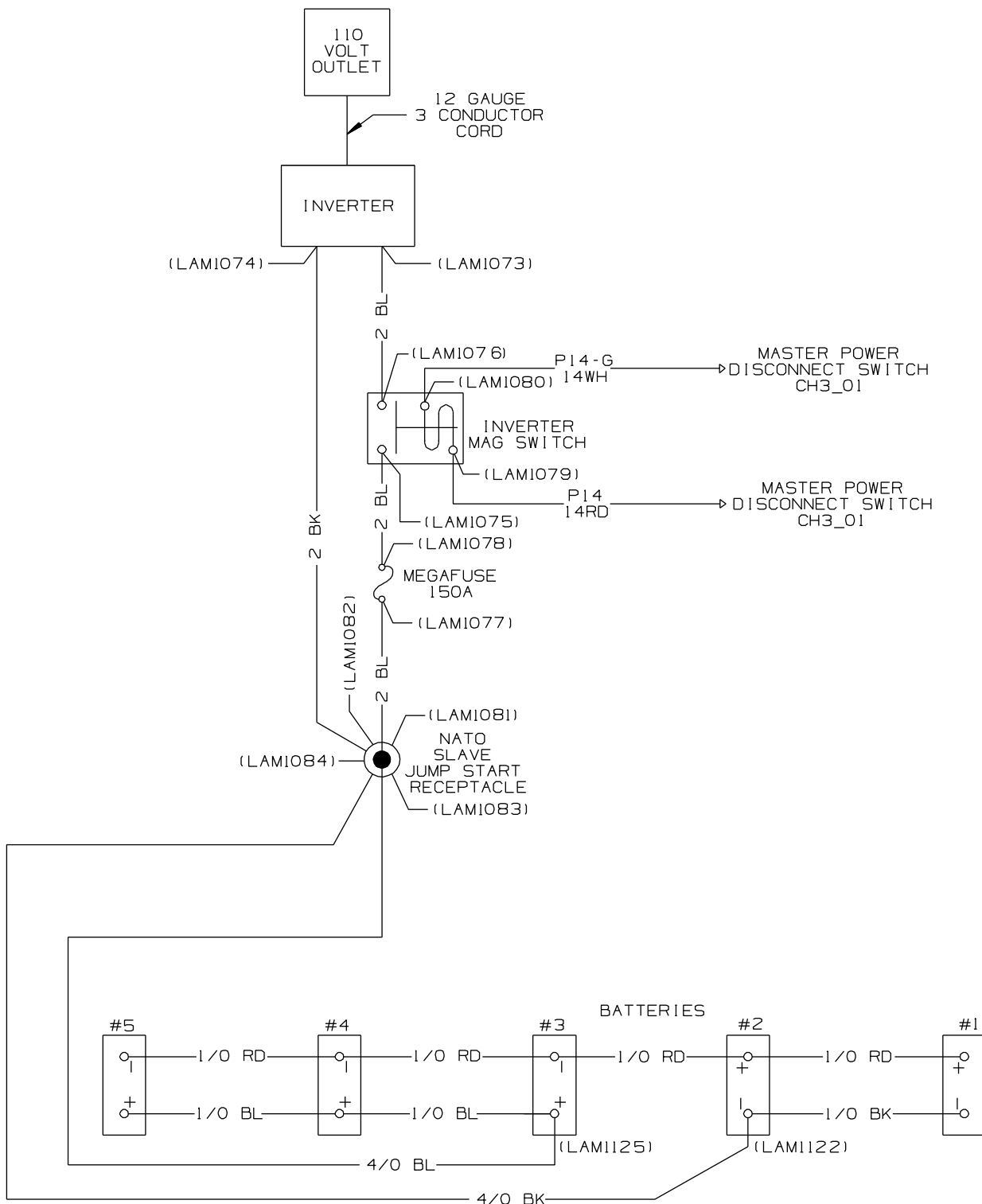

B235012394

Figure 47. CH7_07, 110V AC Power.

ELECTRICAL SYSTEM SCHEMATICS - (CONTINUED)

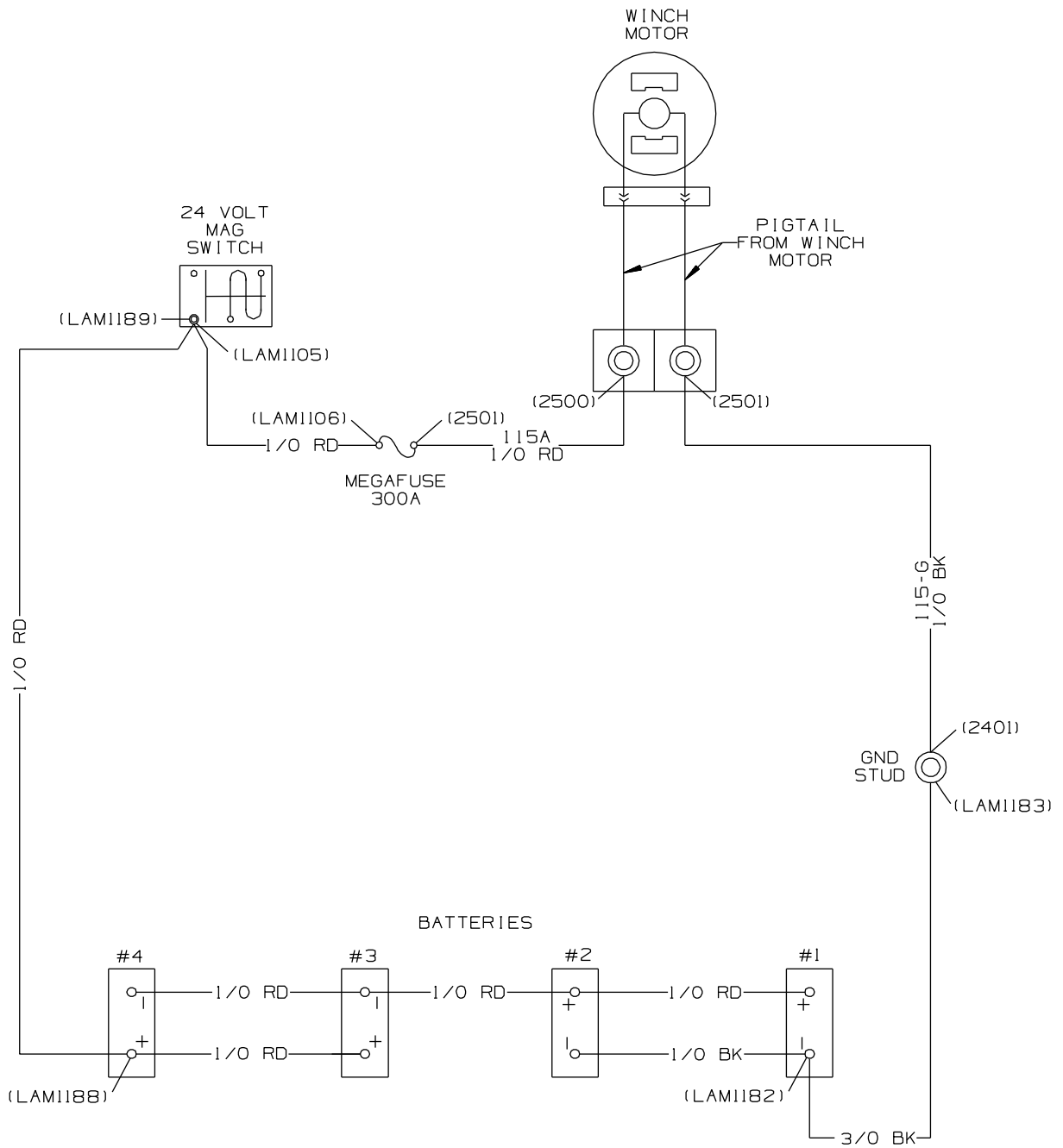

B235001802

Figure 48. CH7_08, Winch Power Cables.

ELECTRICAL SYSTEM SCHEMATICS - (CONTINUED)

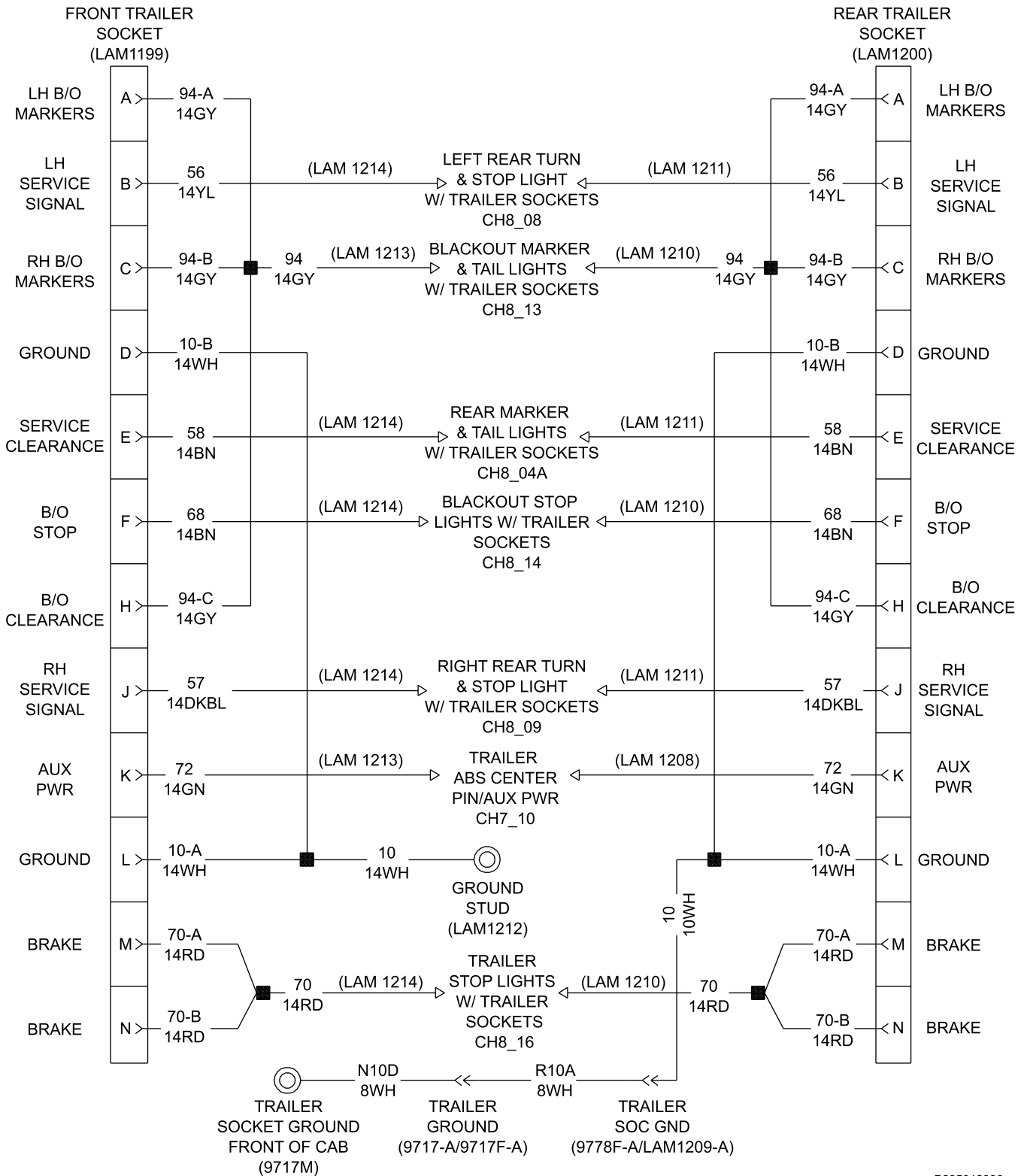

B235012396

Figure 49. CH7_09, Trailer Sockets – Front and Rear.

ELECTRICAL SYSTEM SCHEMATICS - (CONTINUED)

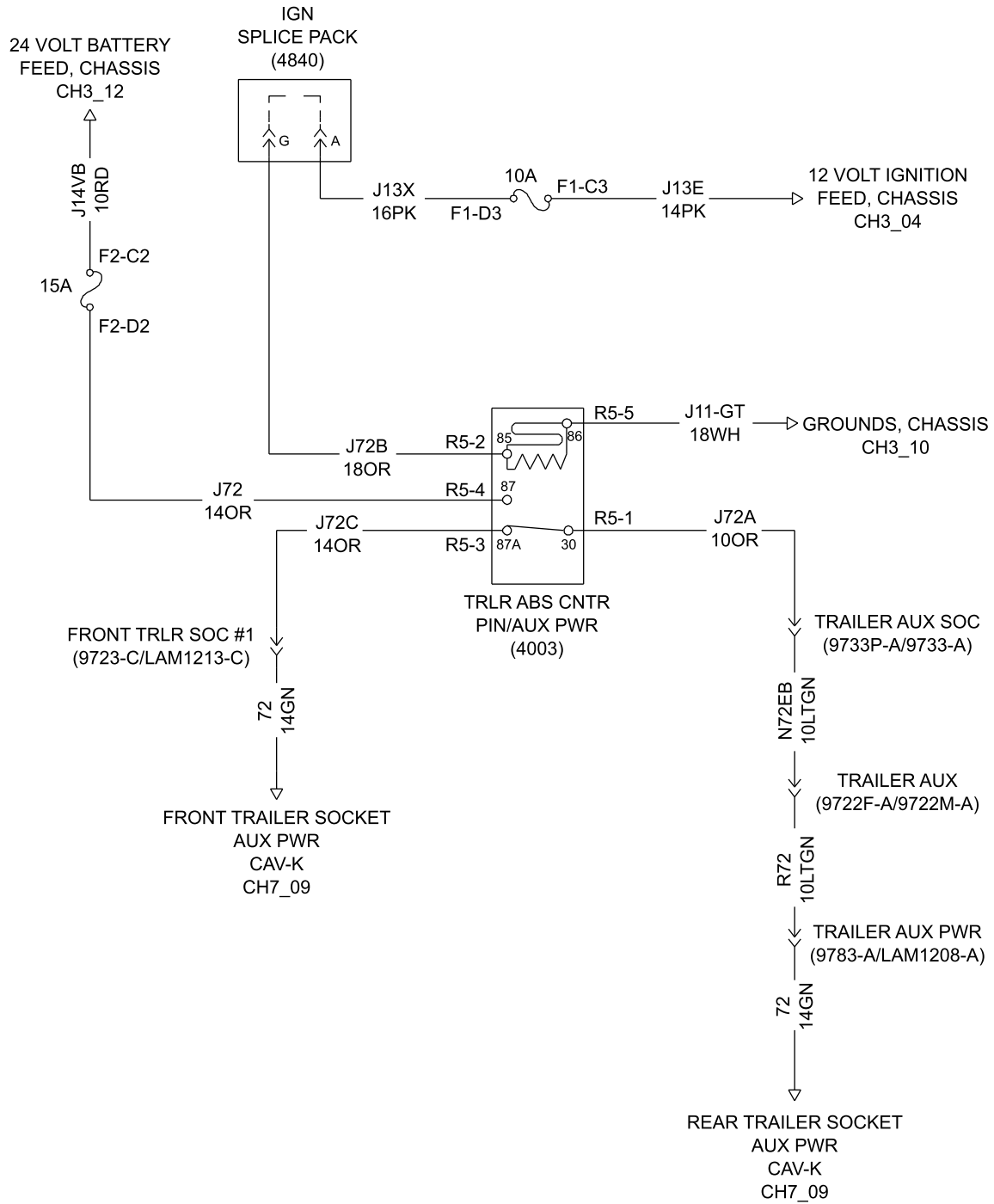

B235012397

Figure 50. CH7_10, Trailer ABS Center Pin Auxiliary Power.

ELECTRICAL SYSTEM SCHEMATICS - (CONTINUED)

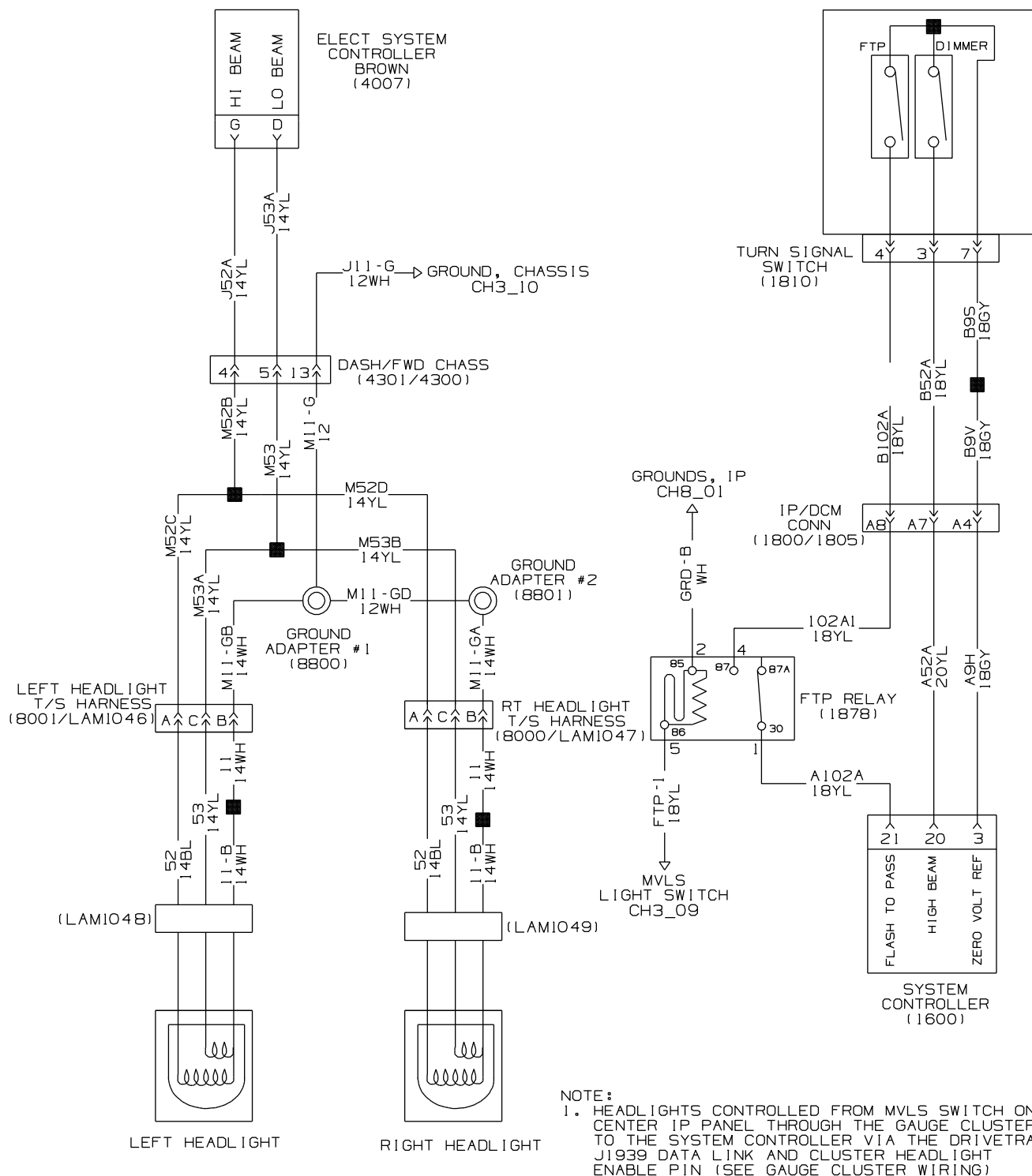
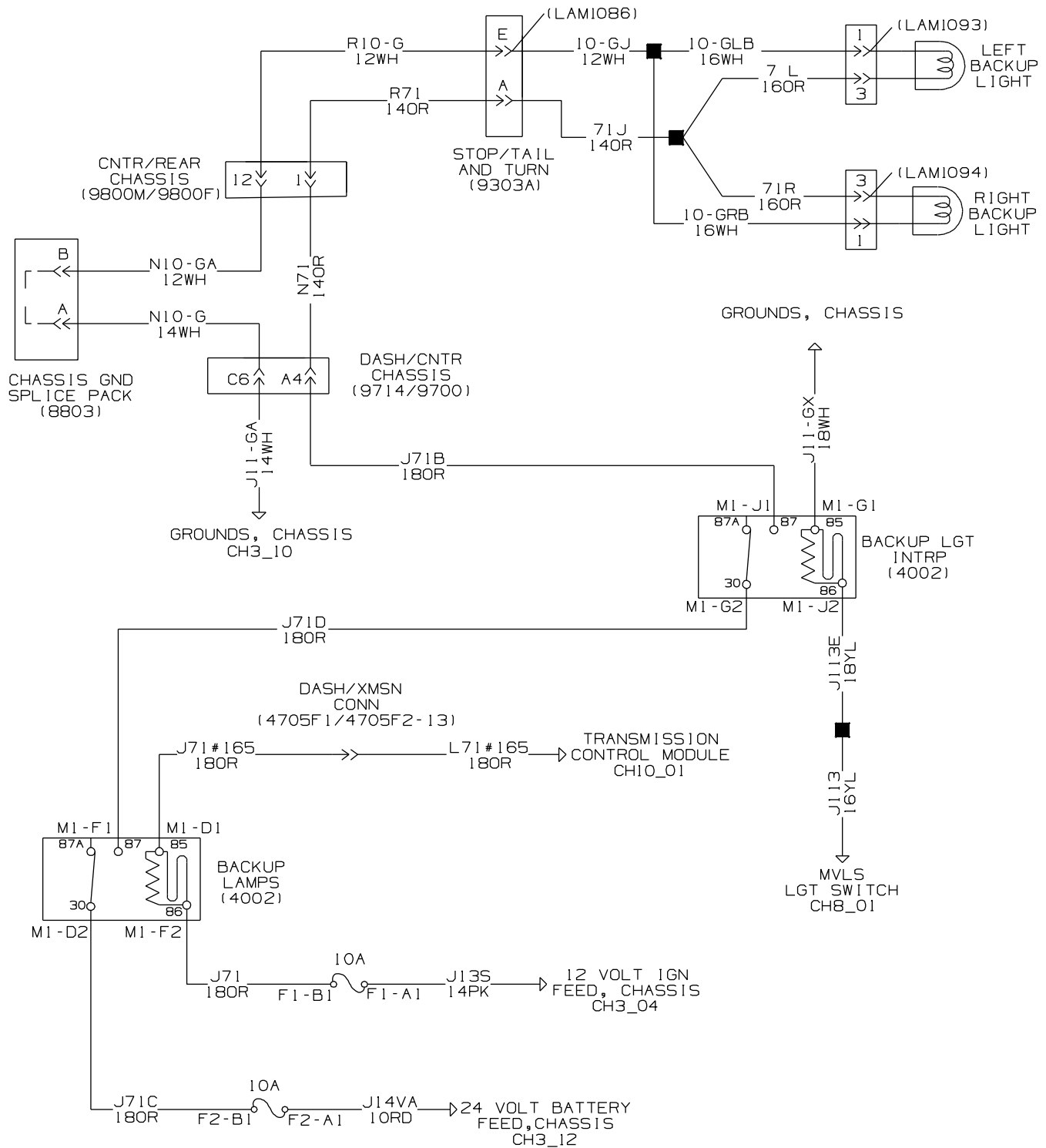

Figure 52. CH8_02, Service Headlights.

B235012399

ELECTRICAL SYSTEM SCHEMATICS - (CONTINUED)



B235012400

Figure 53. CH8_03, Service Backup Lights.

ELECTRICAL SYSTEM SCHEMATICS - (CONTINUED)

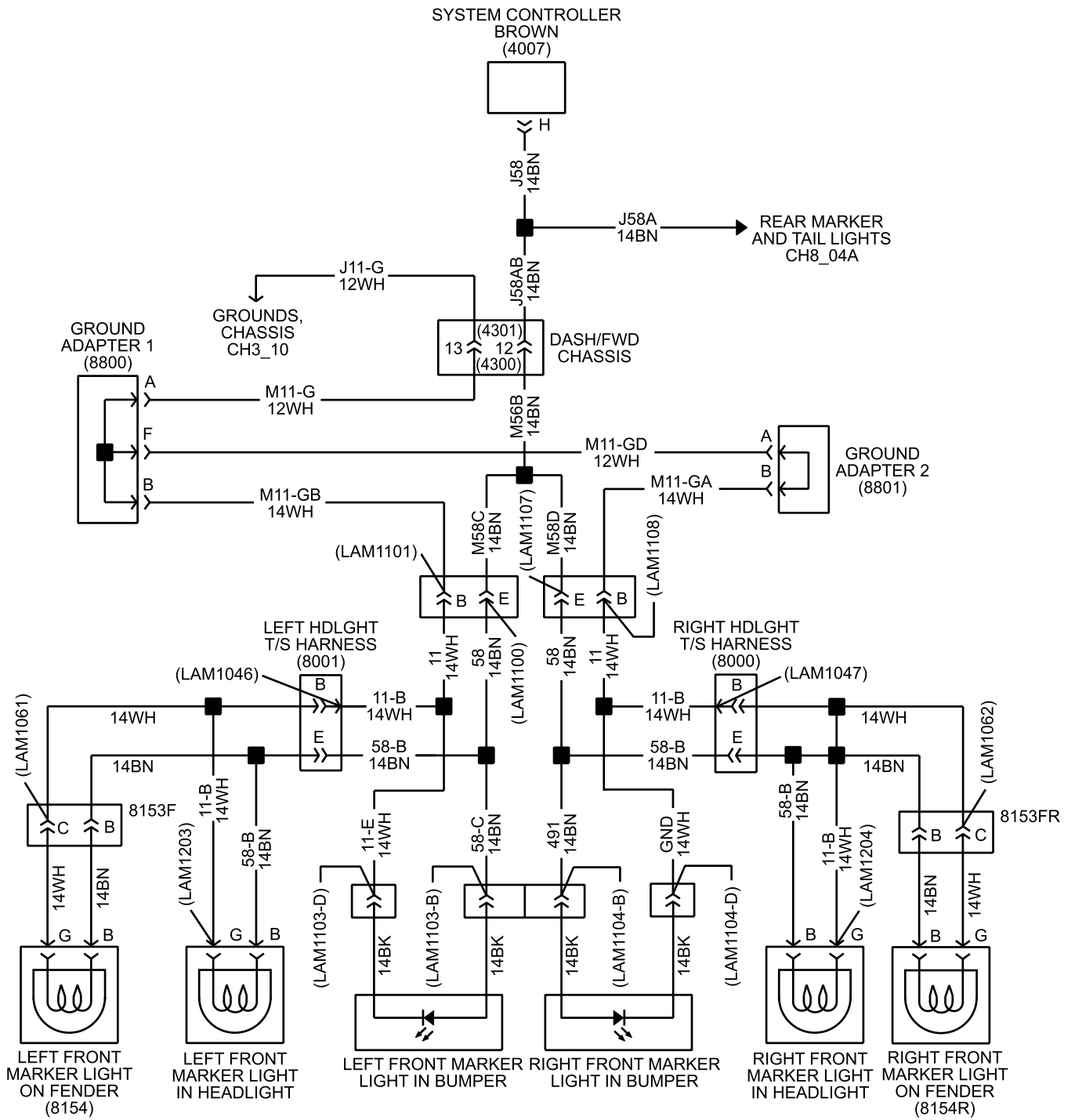

B235012401

Figure 54. CH8_04, Service Lights – Front Marker Lights.

ELECTRICAL SYSTEM SCHEMATICS - (CONTINUED)

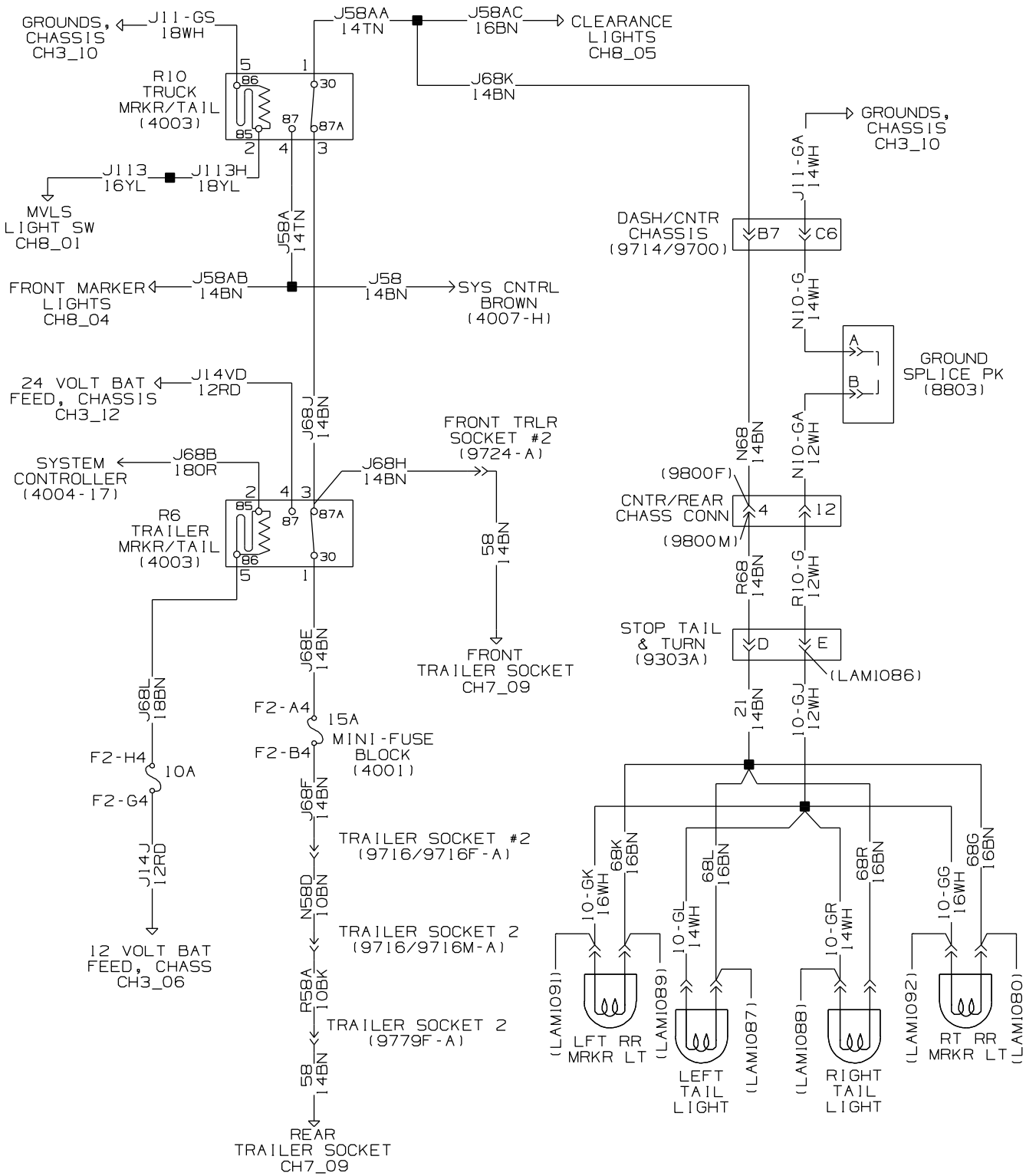

Figure 55. CH8_04A, Service Lights – Rear Marker and Taillights with Trailer Sockets.

B235012402

ELECTRICAL SYSTEM SCHEMATICS - (CONTINUED)

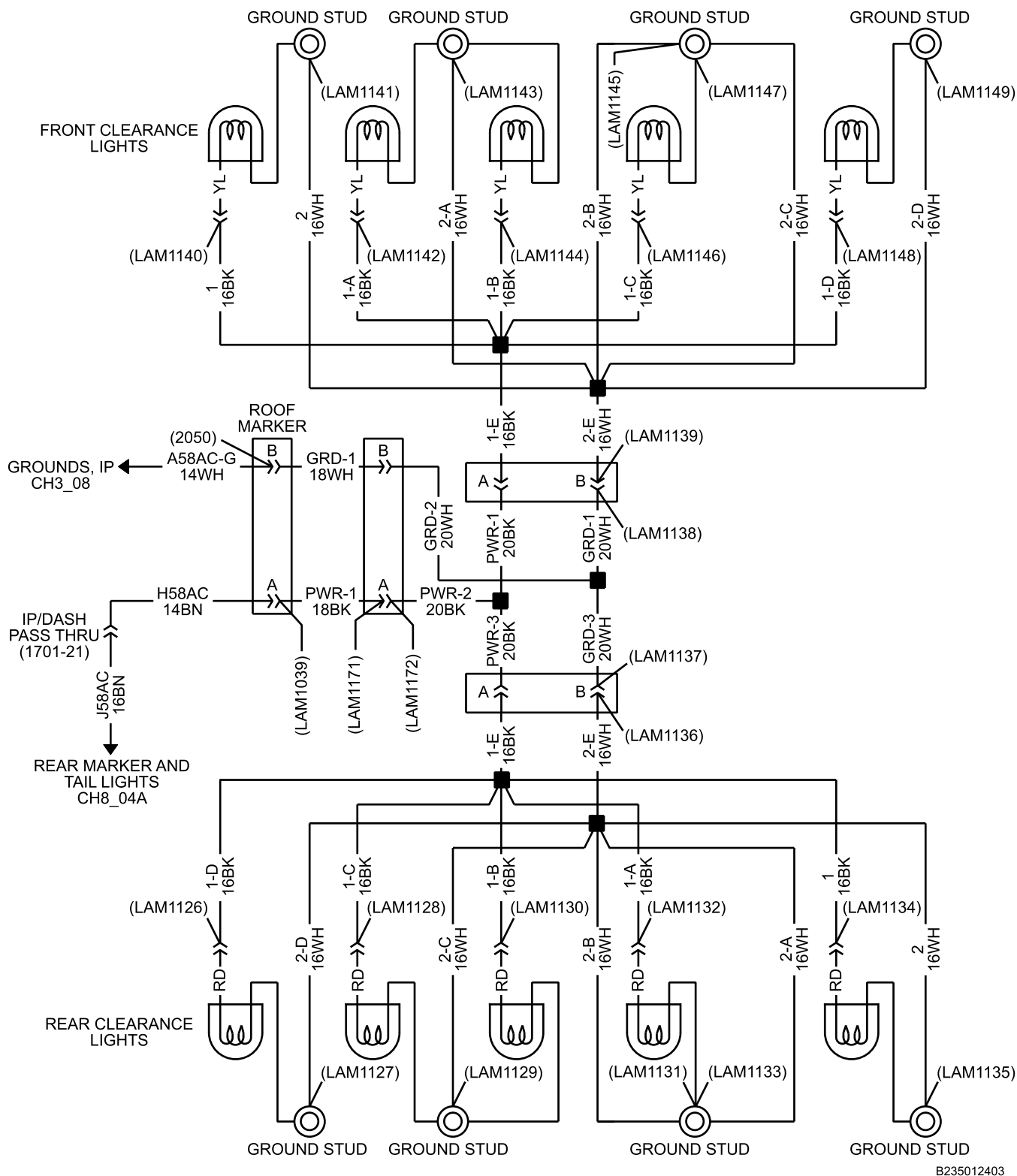
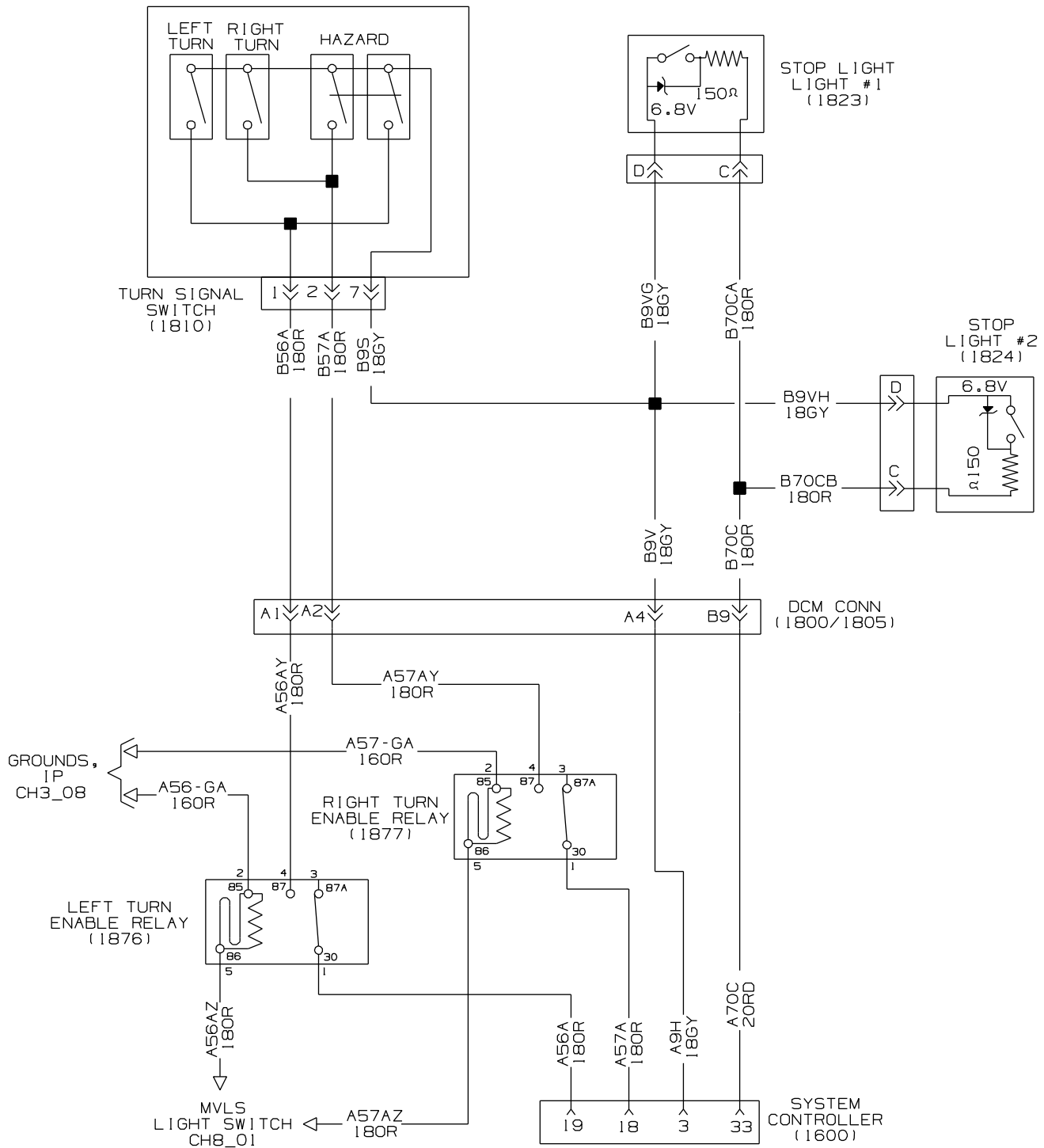

Figure 56. CH8_05, Service Lights – Clearance.

ELECTRICAL SYSTEM SCHEMATICS - (CONTINUED)



B235012404

Figure 57. CH8_06, Service Lights – Turn Signal and Stop Light Relays and Switch.

ELECTRICAL SYSTEM SCHEMATICS - (CONTINUED)

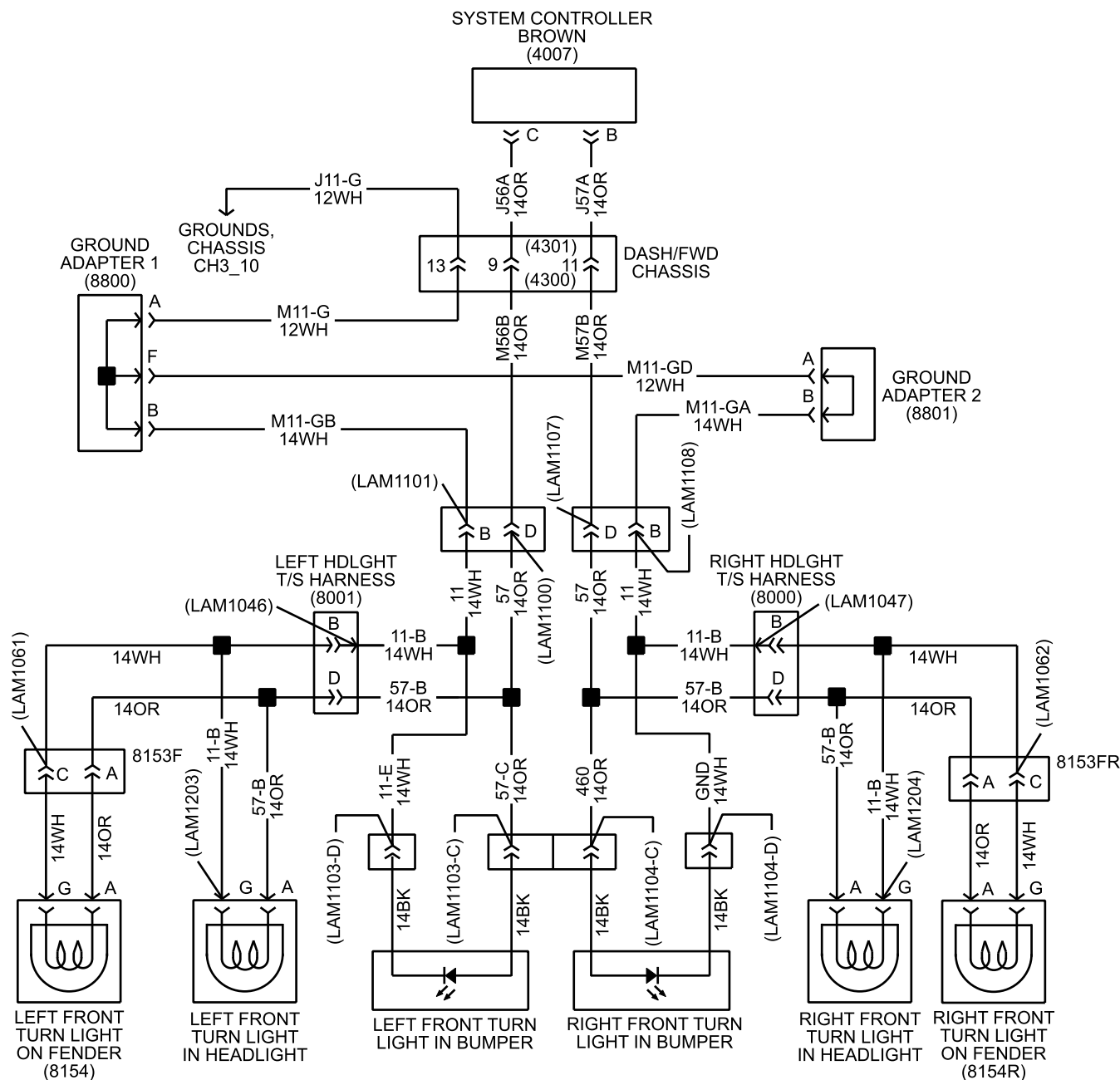

B235012405

Figure 58. CH8_07, Service Lights – Front Turn Signal Lights.

ELECTRICAL SYSTEM SCHEMATICS - (CONTINUED)

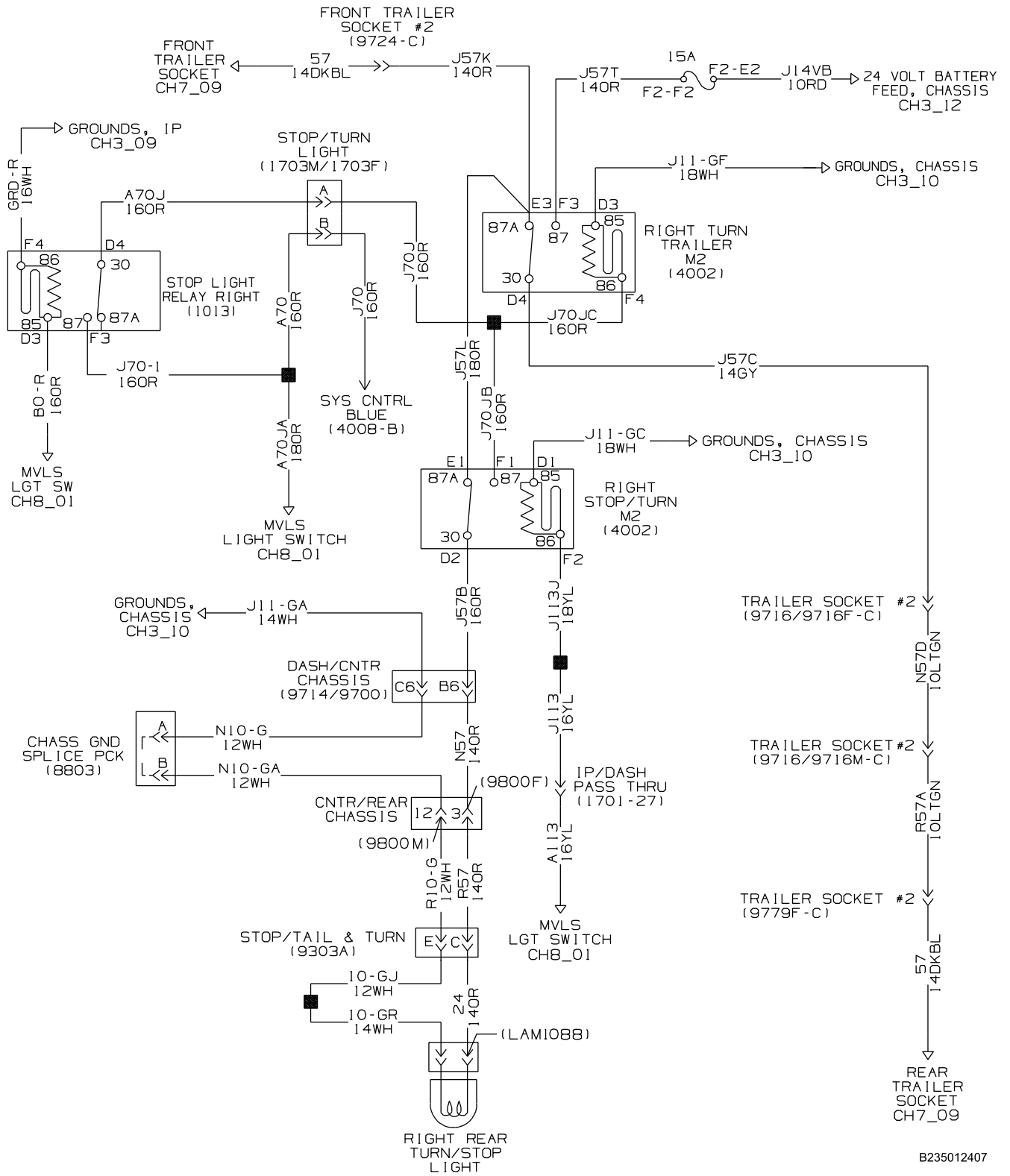
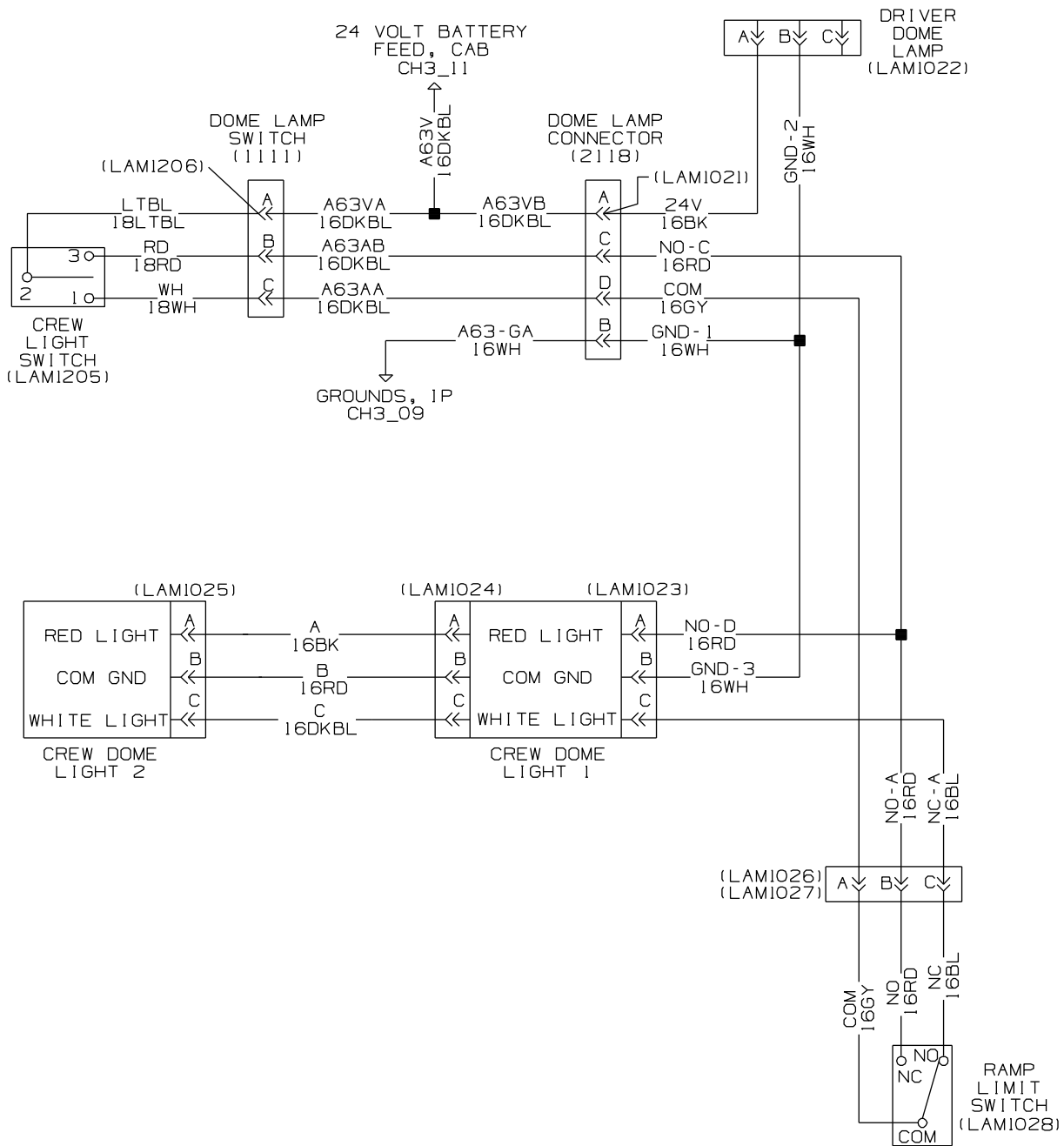

Figure 60. CH8_09, Service Lights – Right Rear Turn and Stop Light with Trailer Sockets.

ELECTRICAL SYSTEM SCHEMATICS - (CONTINUED)



NOTE: RAMP LIMIT SWITCH SHOWN WITH RAMP DOOR CLOSED

B235012408

Figure 61. CH8_10, Dome Lights.

ELECTRICAL SYSTEM SCHEMATICS - (CONTINUED)

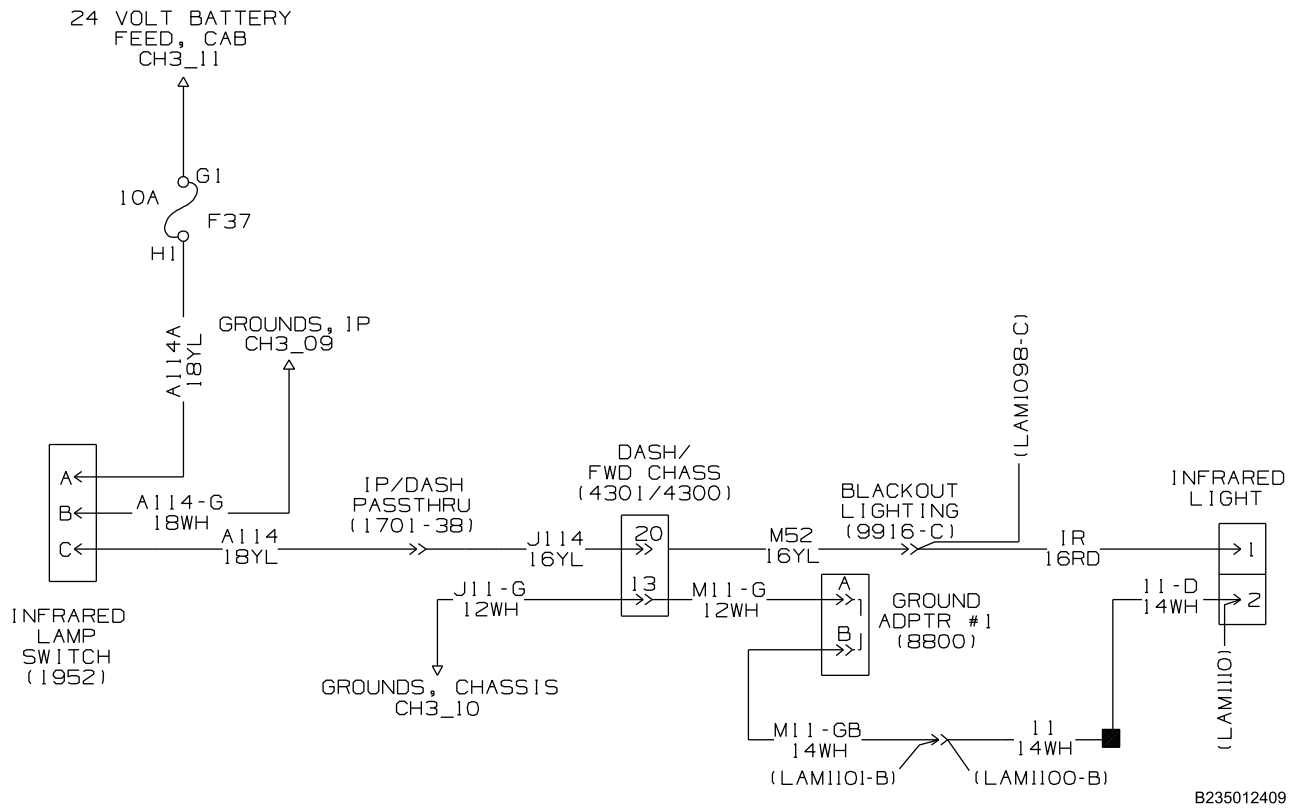

B235012409

Figure 62. CH8_11, Infrared Driving Light.

ELECTRICAL SYSTEM SCHEMATICS - (CONTINUED)

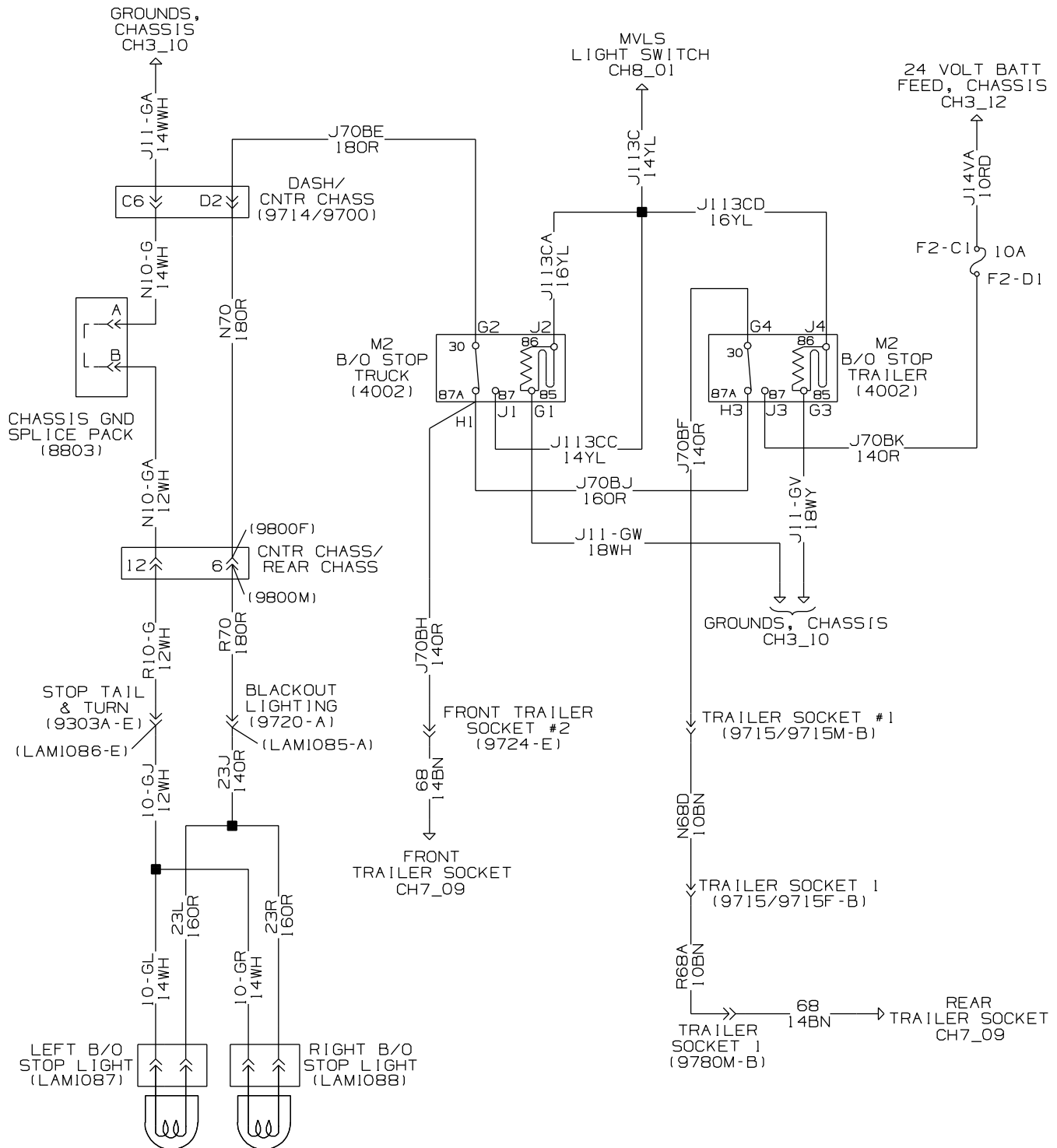

B235012412

Figure 65. CH8_14, Blackout Stop Lights with Trailer Sockets.

ELECTRICAL SYSTEM SCHEMATICS - (CONTINUED)

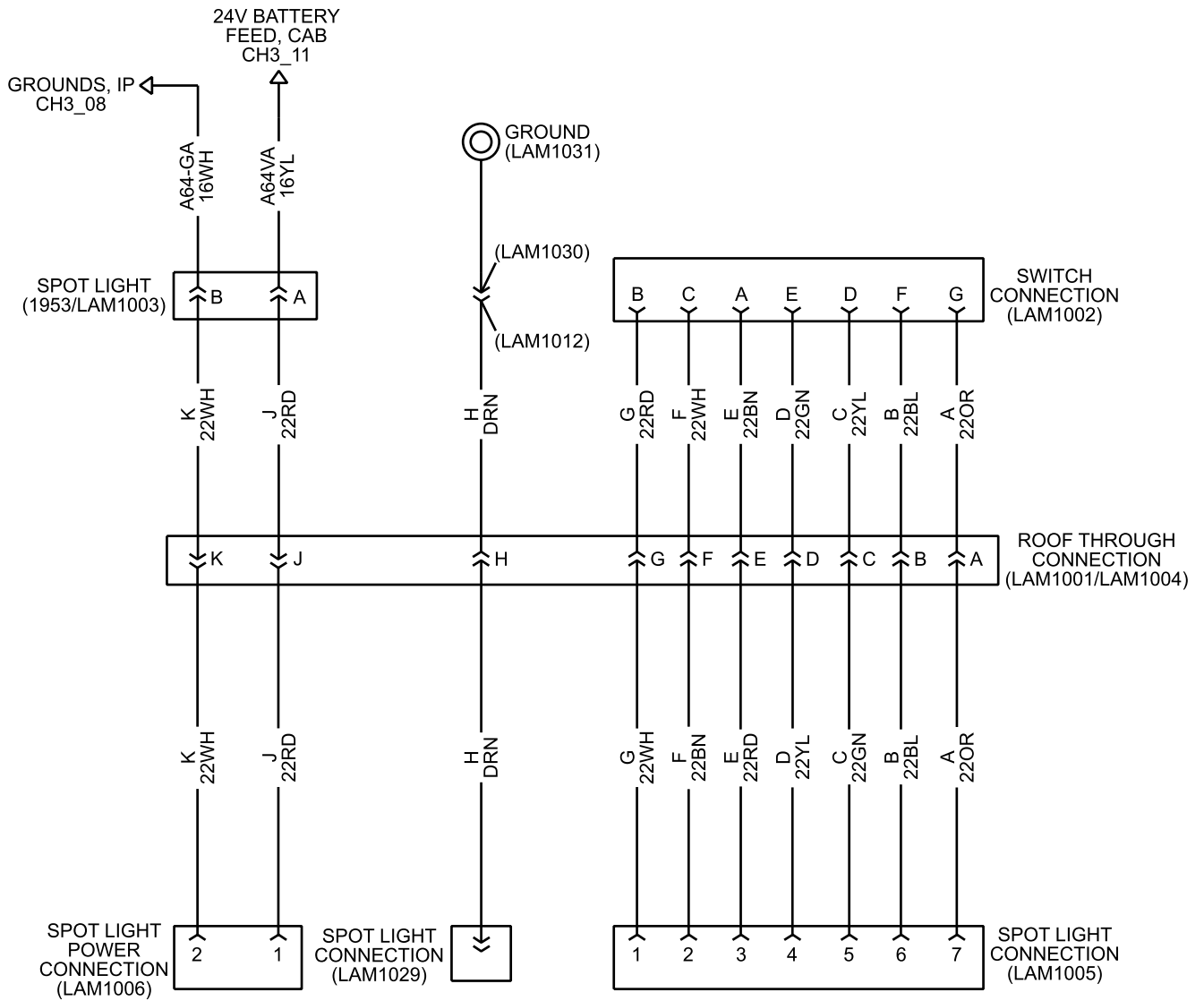

B235012413

Figure 66. CH8_15, Remote Control Spotlight Power.

ELECTRICAL SYSTEM SCHEMATICS - (CONTINUED)

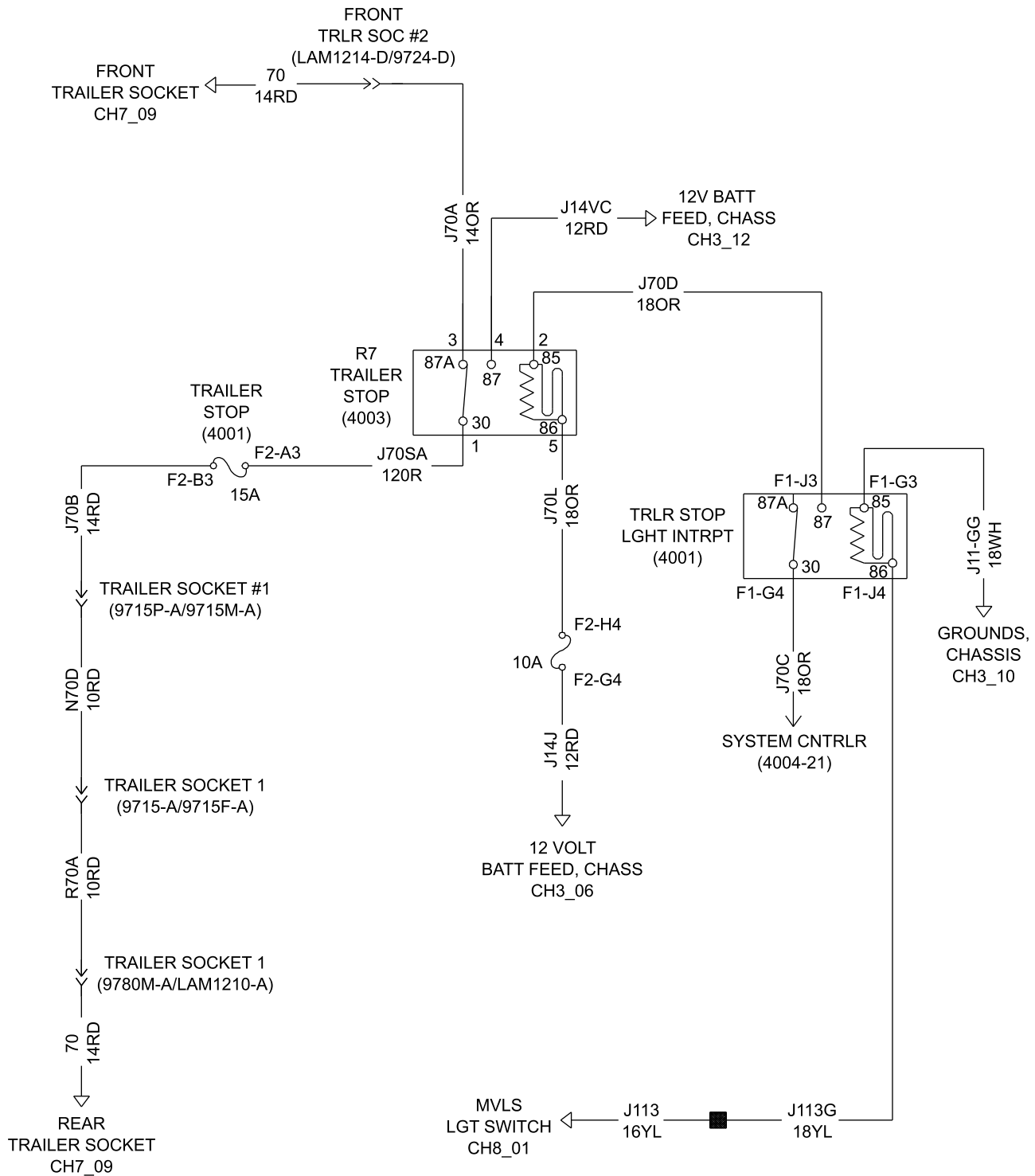

B235012414

Figure 67. CH8_16, Trailer Stop Lights with Trailer Sockets.

ELECTRICAL SYSTEM SCHEMATICS - (CONTINUED)

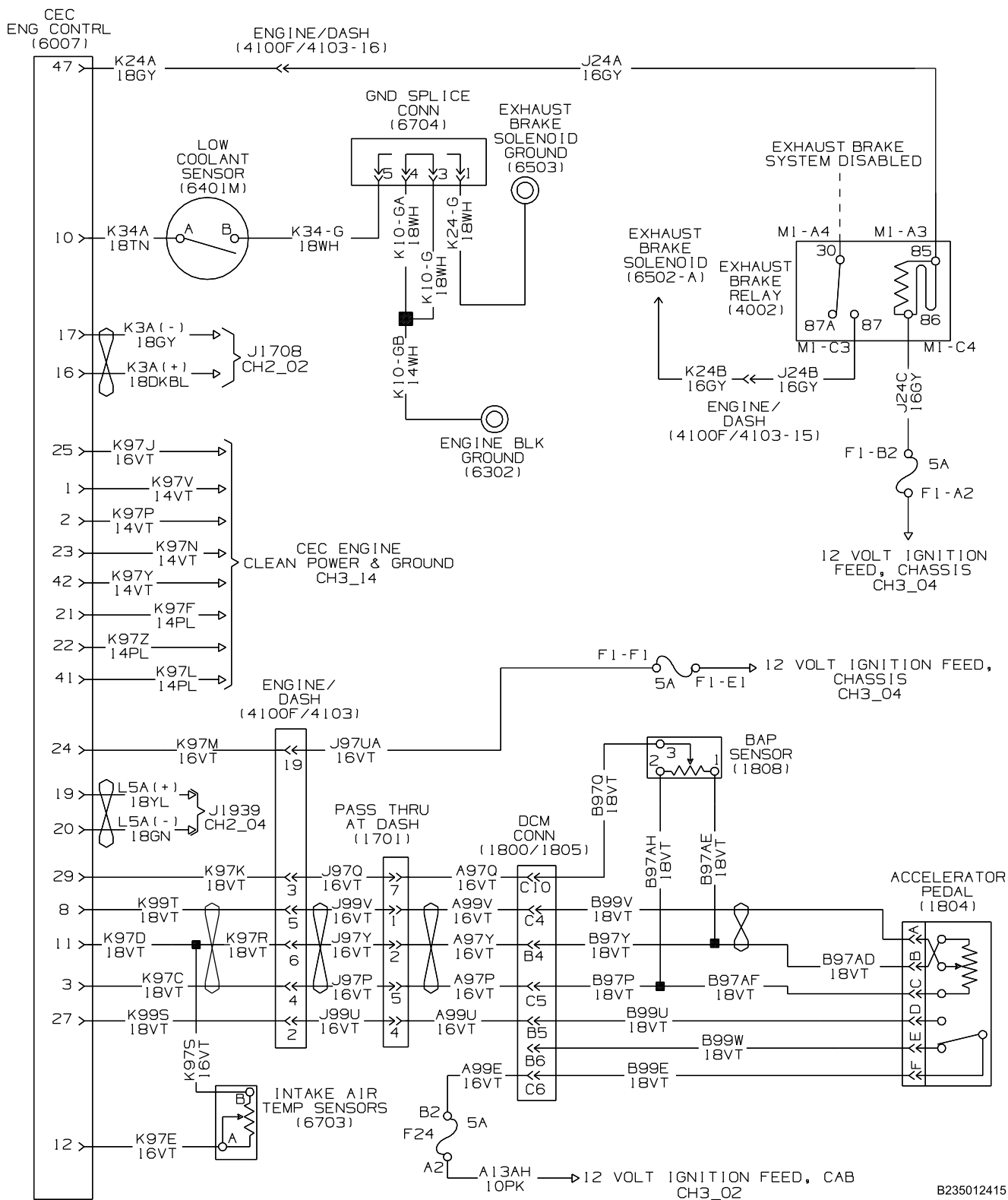

B235012415

Figure 68. CH9_01, I6 - HEUI Engine Controls.

ELECTRICAL SYSTEM SCHEMATICS - (CONTINUED)

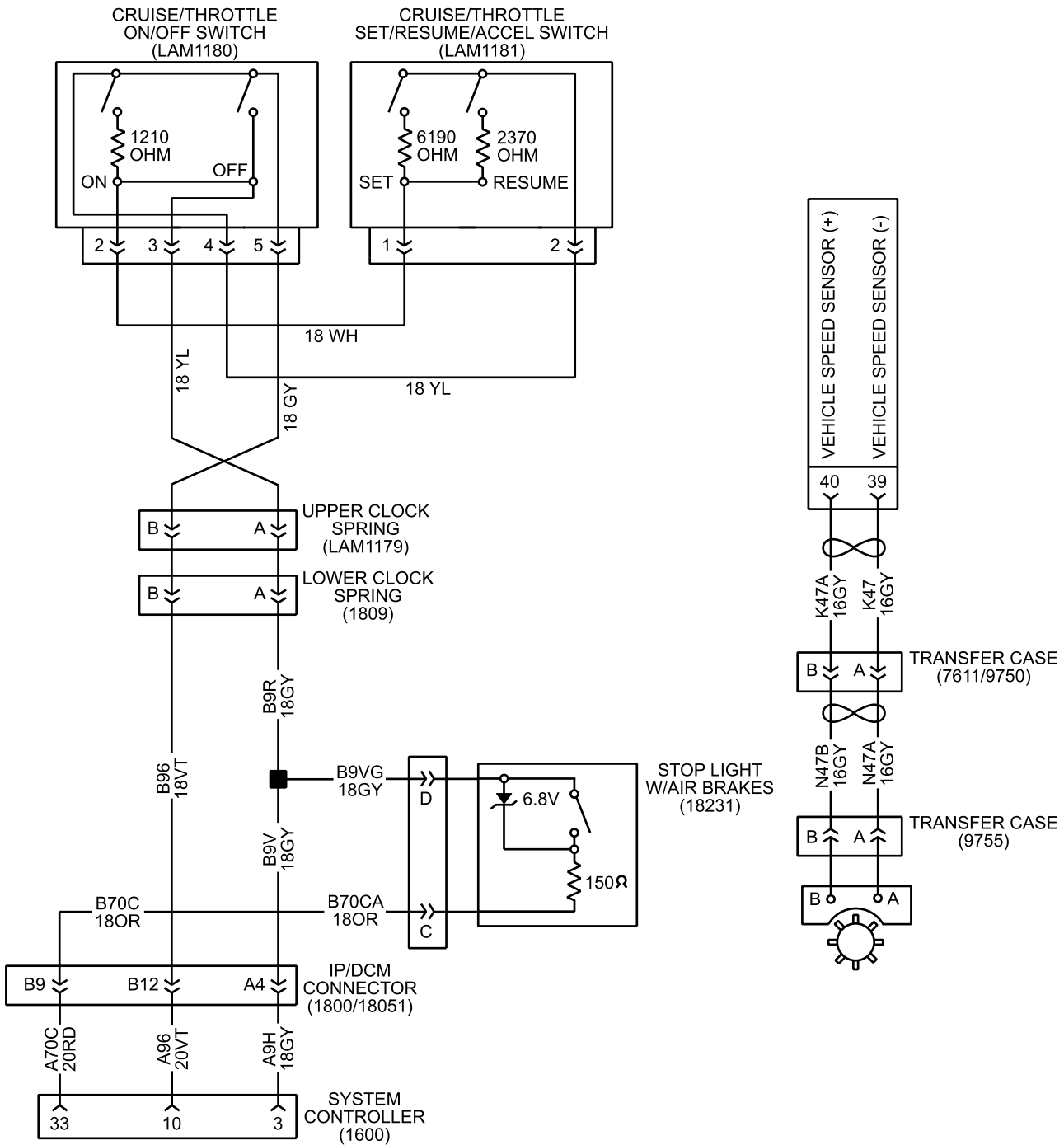

B235001770

Figure 69. CH9_02, I6 - HEUI Engine Controls – Cruise Control.

ELECTRICAL SYSTEM SCHEMATICS - (CONTINUED)

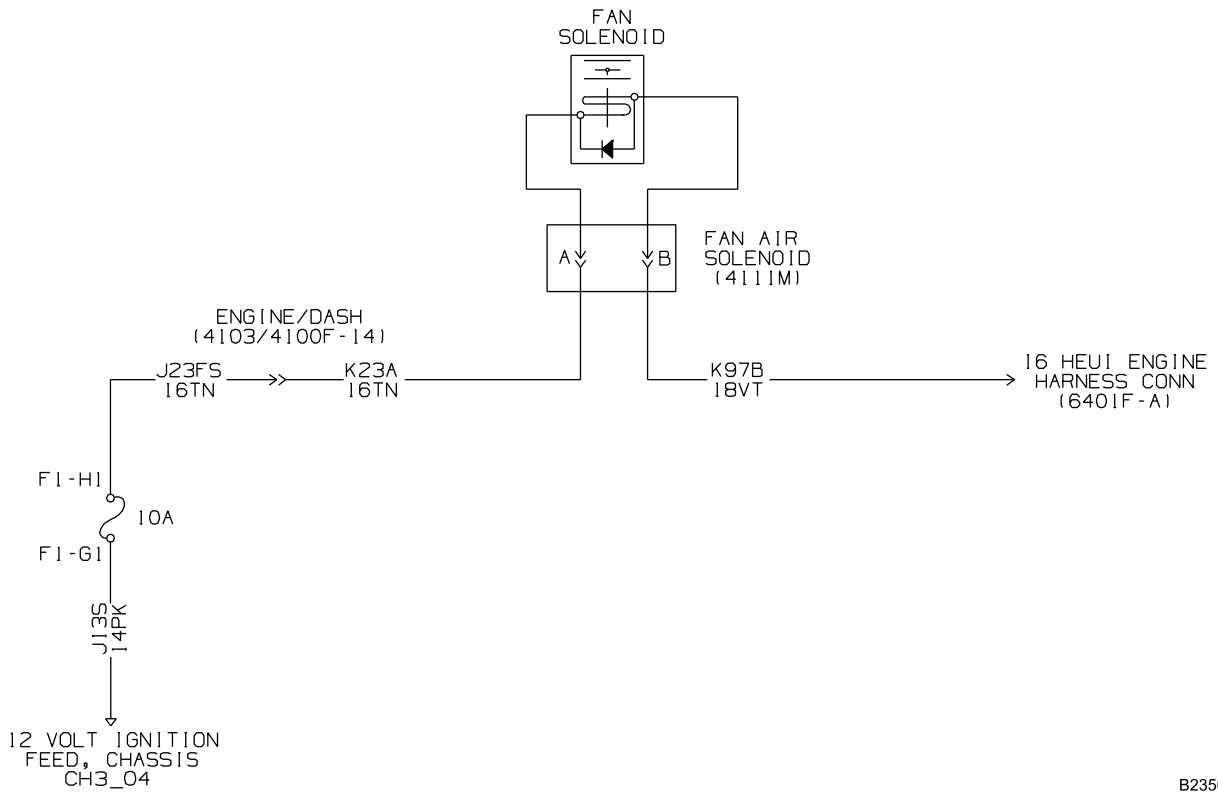

B235012417

Figure 70. CH9_03, I6 - HEUI Engine Fan and Wiring with Air Clutch.

ELECTRICAL SYSTEM SCHEMATICS - (CONTINUED)

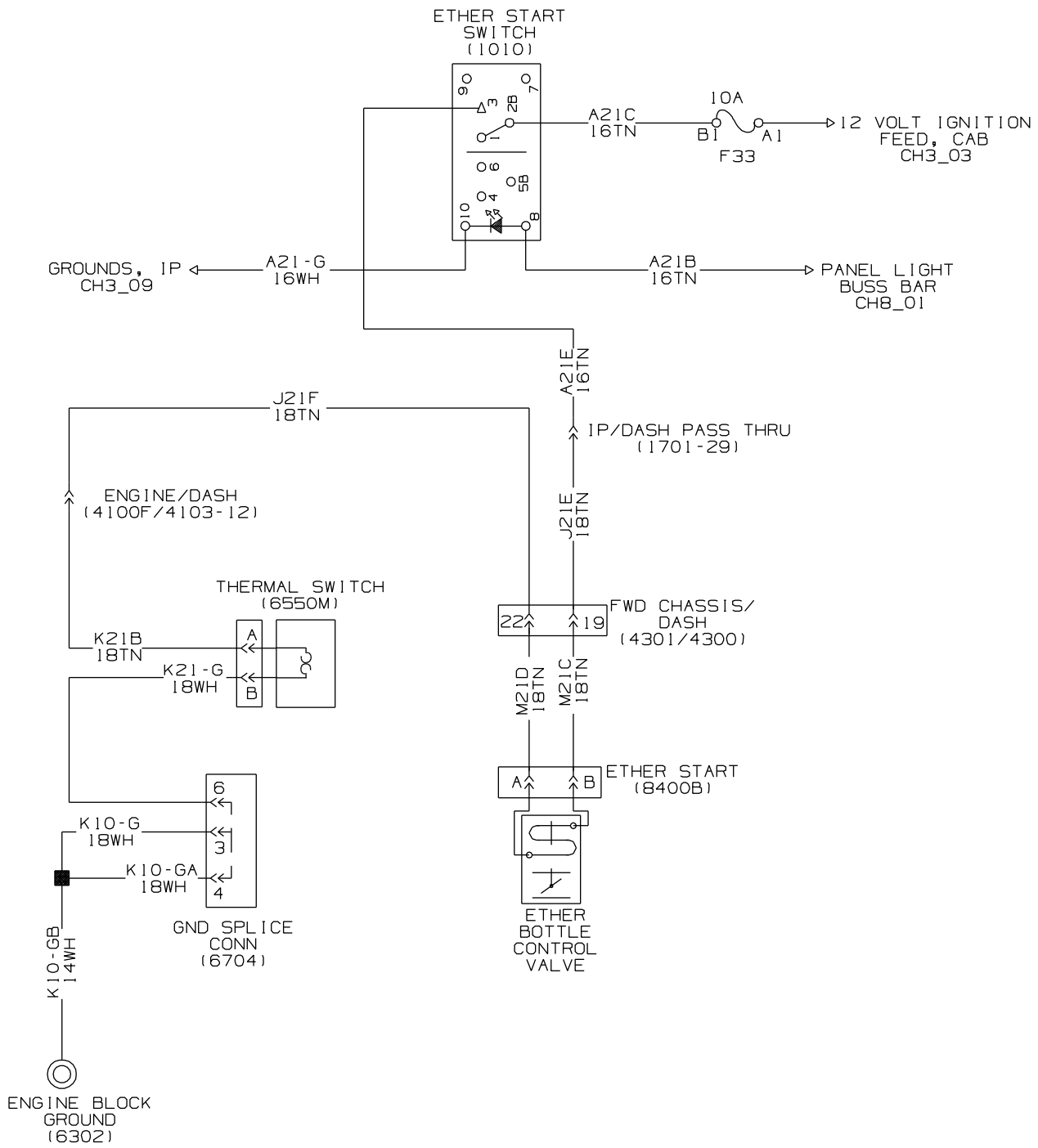

B235012418

Figure 71. CH9_04, I6 - HEUI Engine - Ether Start.

ELECTRICAL SYSTEM SCHEMATICS - (CONTINUED)

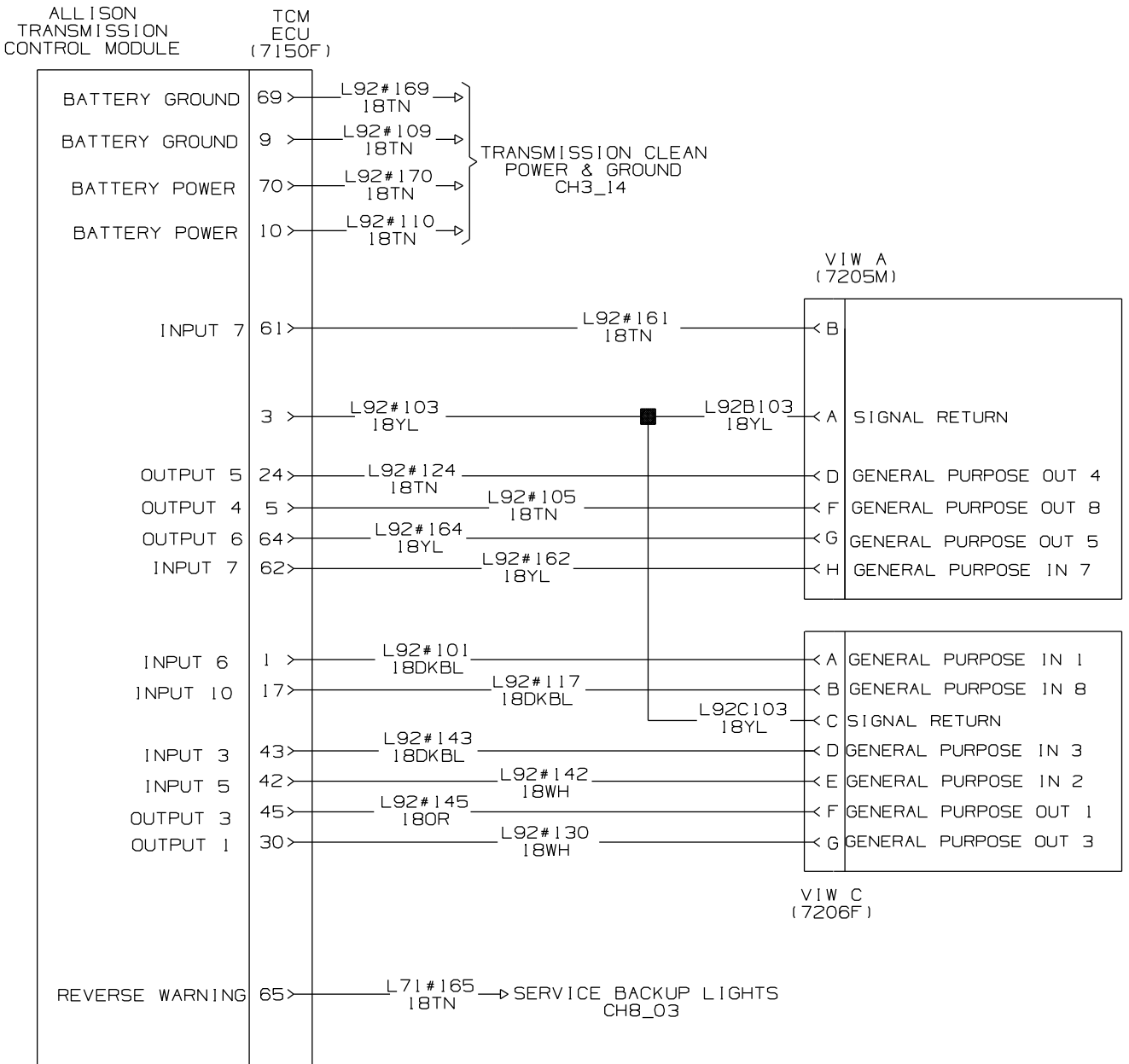

B235012419

Figure 72. CH10_01, Allison WTEC Transmission (1 of 3).

ELECTRICAL SYSTEM SCHEMATICS - (CONTINUED)

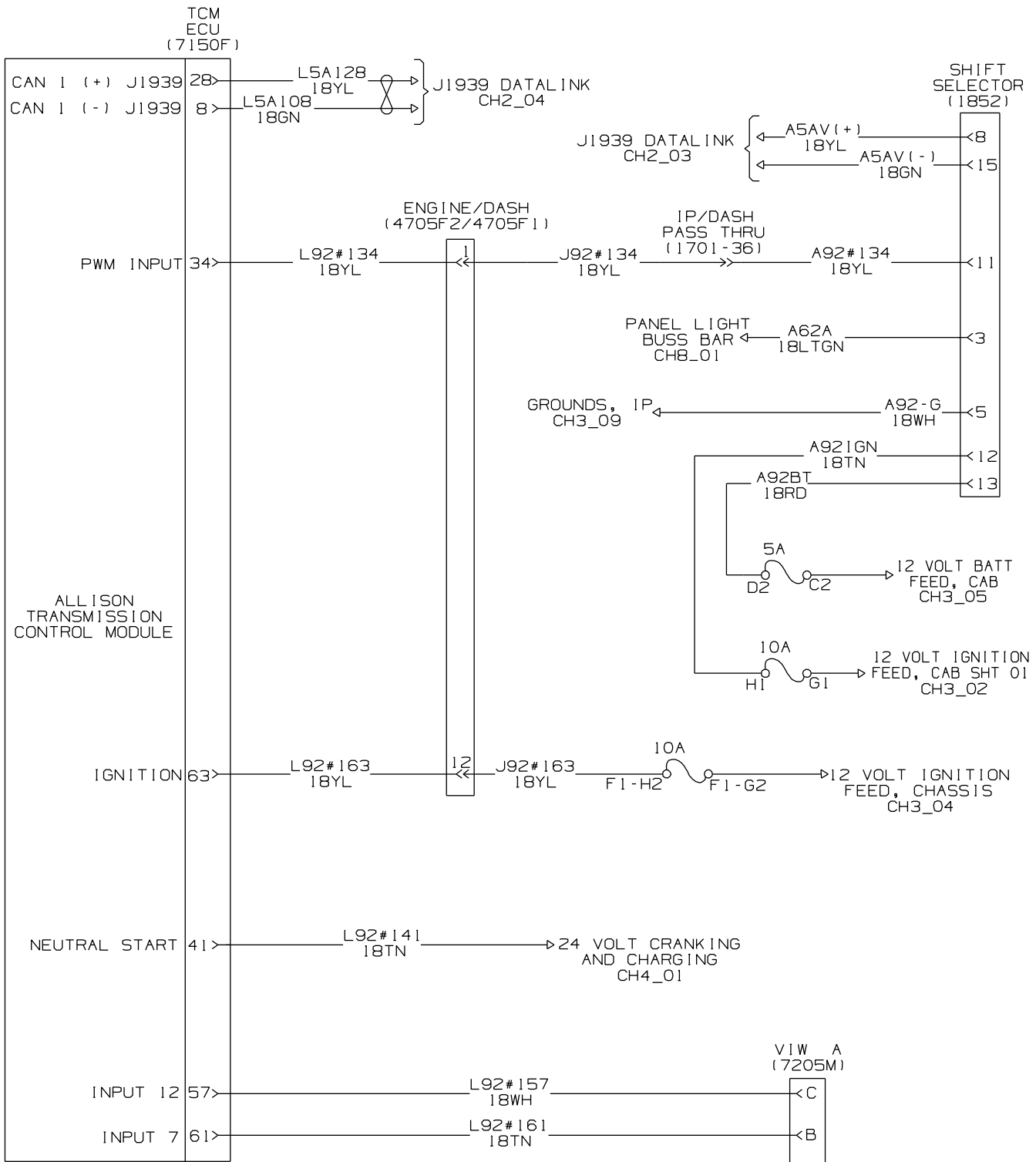

B235012420

Figure 73. CH10_02, Allison WTEC Transmission (2 of 3).

ELECTRICAL SYSTEM SCHEMATICS - (CONTINUED)

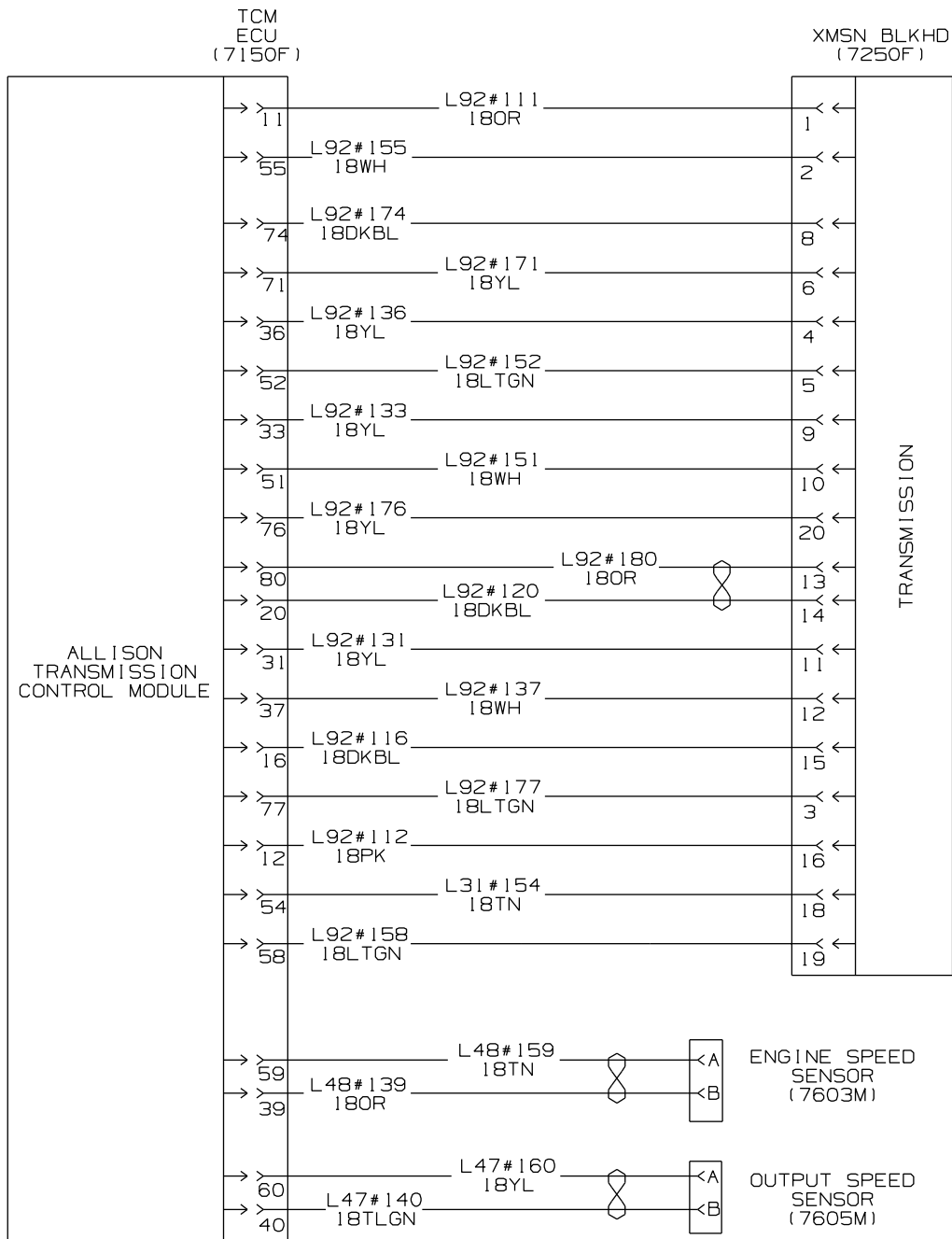

B235001721

Figure 74. CH10_03 Allison WTEC Transmission (3 of 3).

ELECTRICAL SYSTEM SCHEMATICS - (CONTINUED)

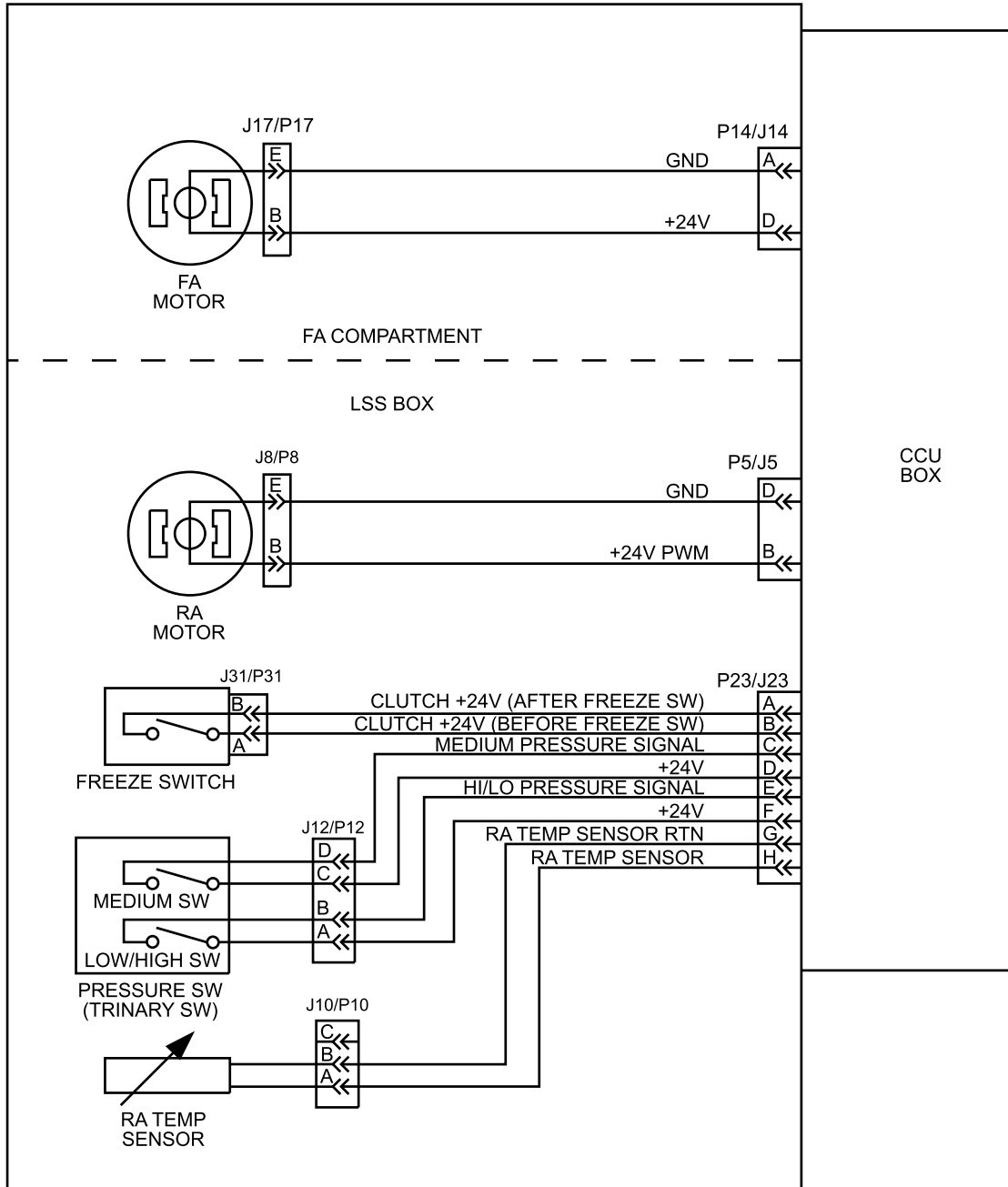

B239102321

Figure 75. CH11_01, HVAC, Cabin (1 of 2).

ELECTRICAL SYSTEM SCHEMATICS - (CONTINUED)

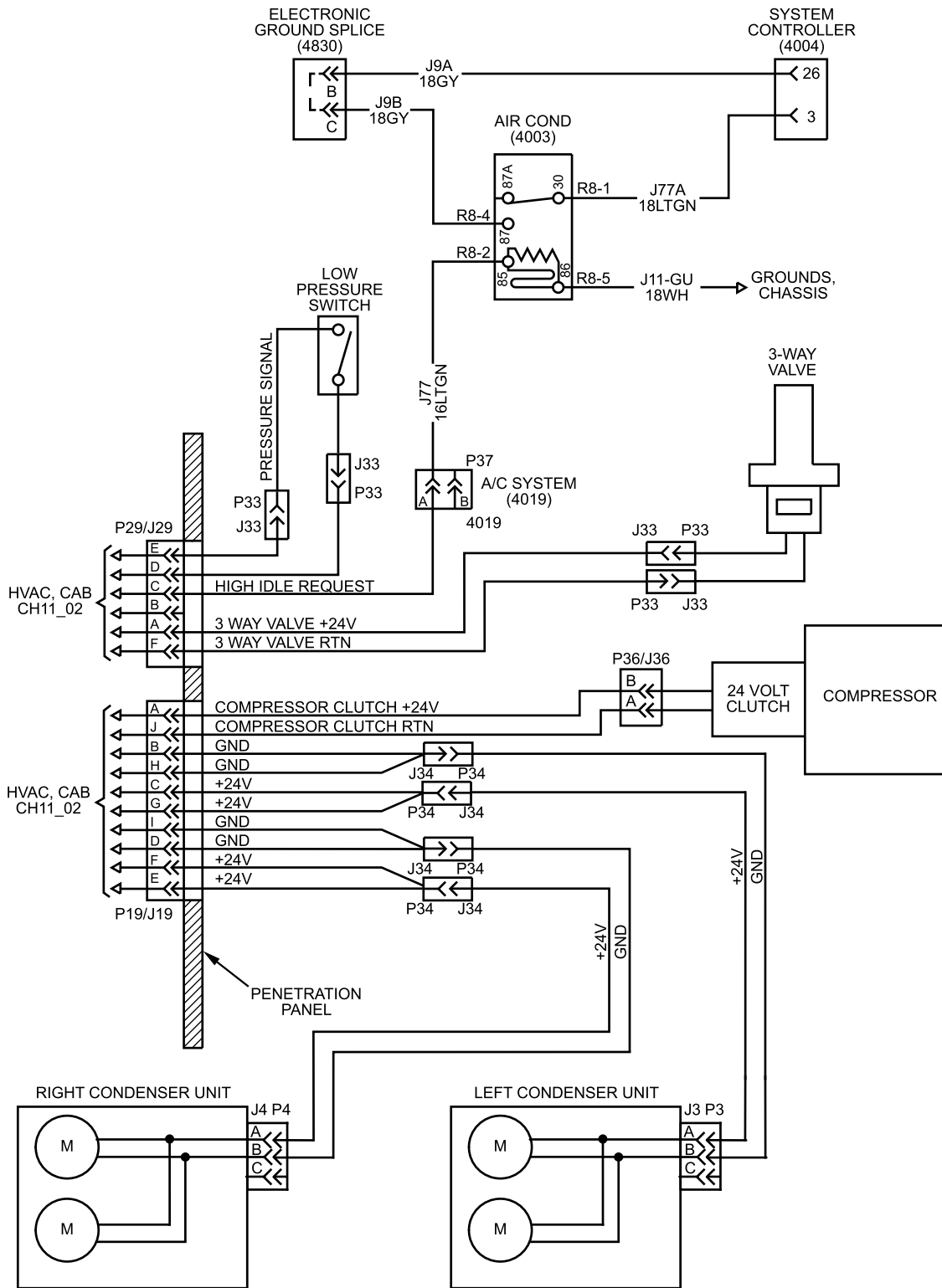

B235012424

Figure 77. CH11_03, HVAC – Engine Compartment.

ELECTRICAL SYSTEM SCHEMATICS - (CONTINUED)

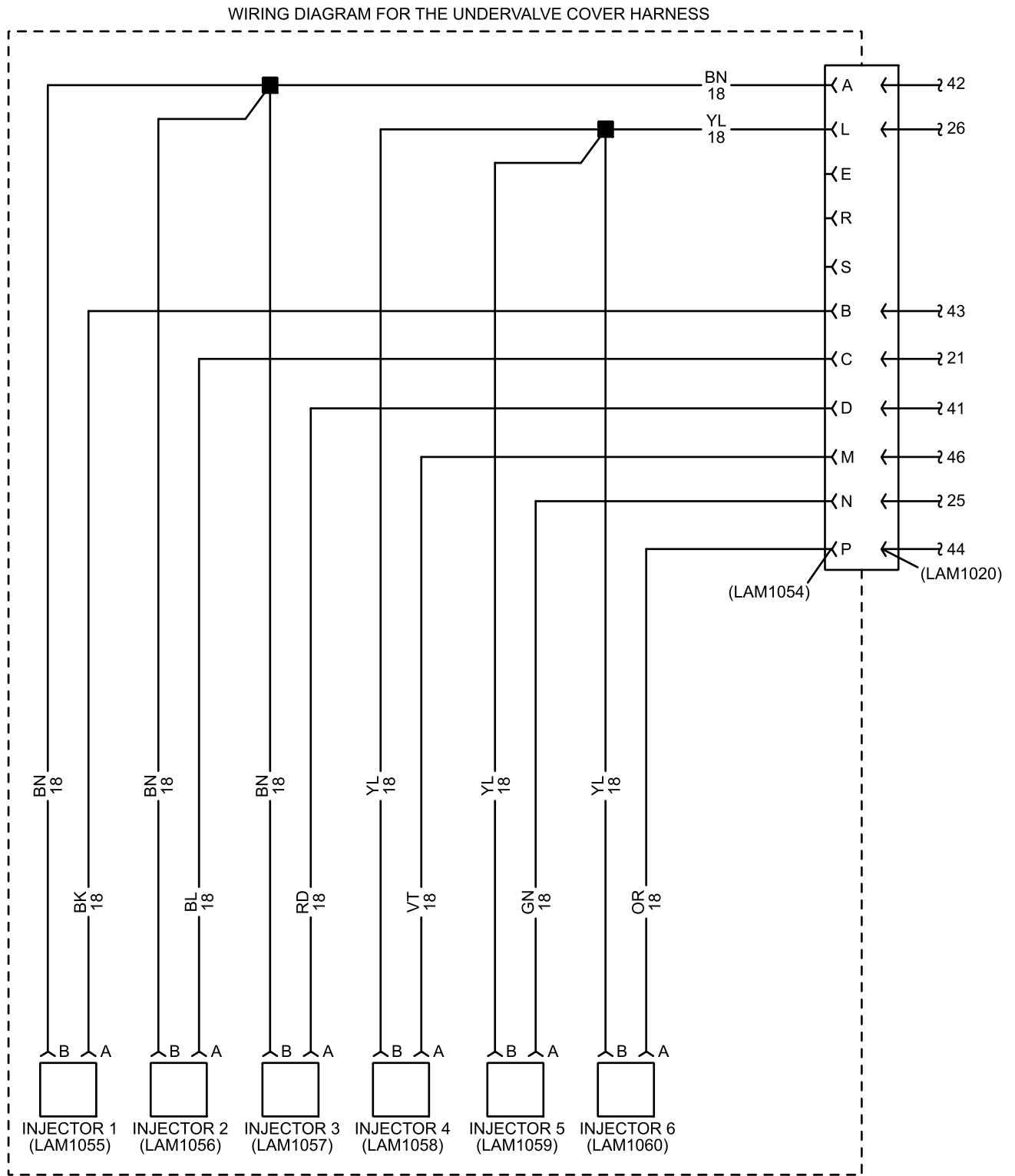

B235005701

Figure 78. 16 - HEUI Engine Controls - Injector Harness.

ELECTRICAL SYSTEM SCHEMATICS - (CONTINUED)

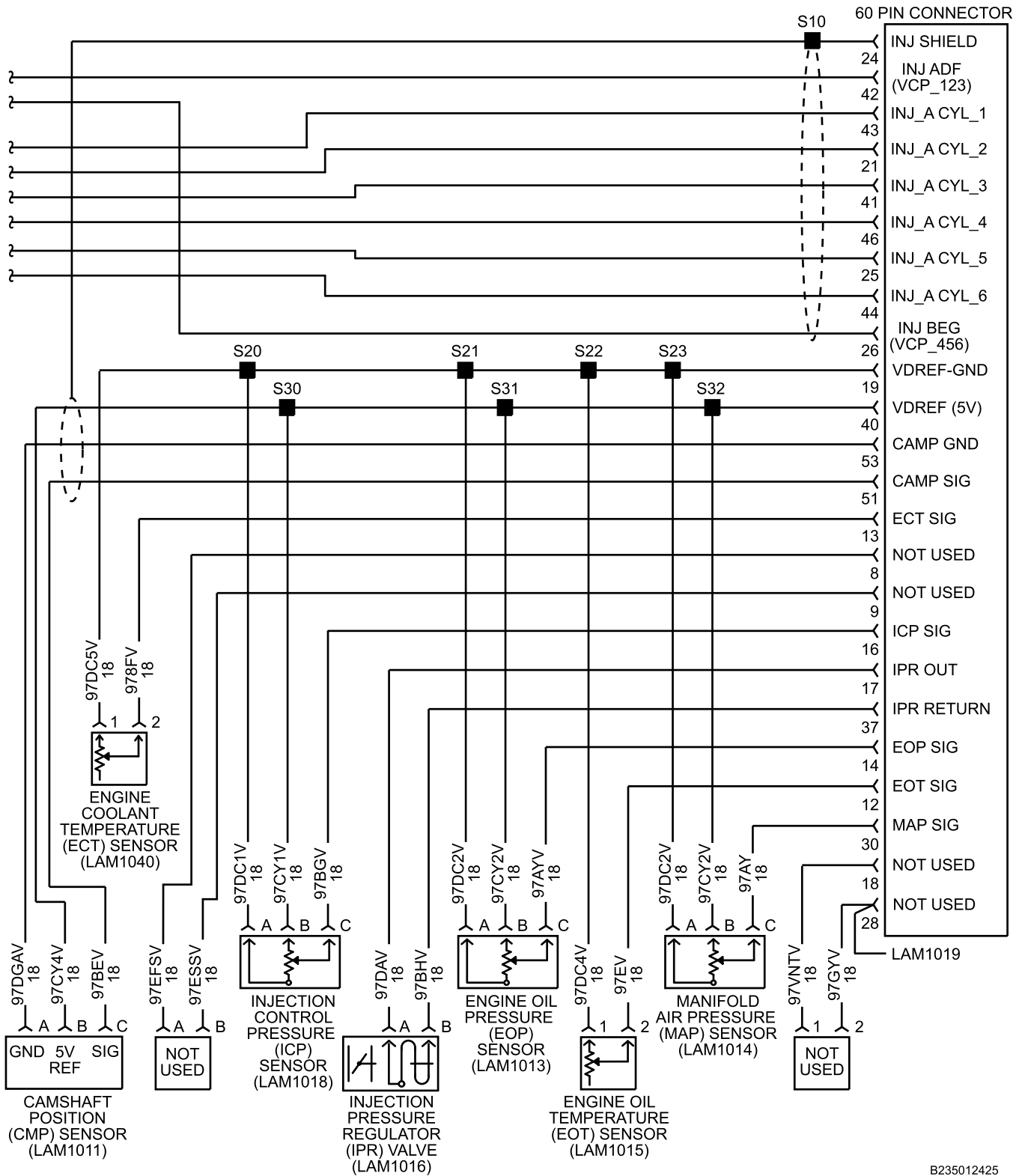

B235012425

Figure 79. I6 - HEUI Engine Controls - Engine Sensor Harness.

ELECTRICAL SYSTEM SCHEMATICS - (CONTINUED)

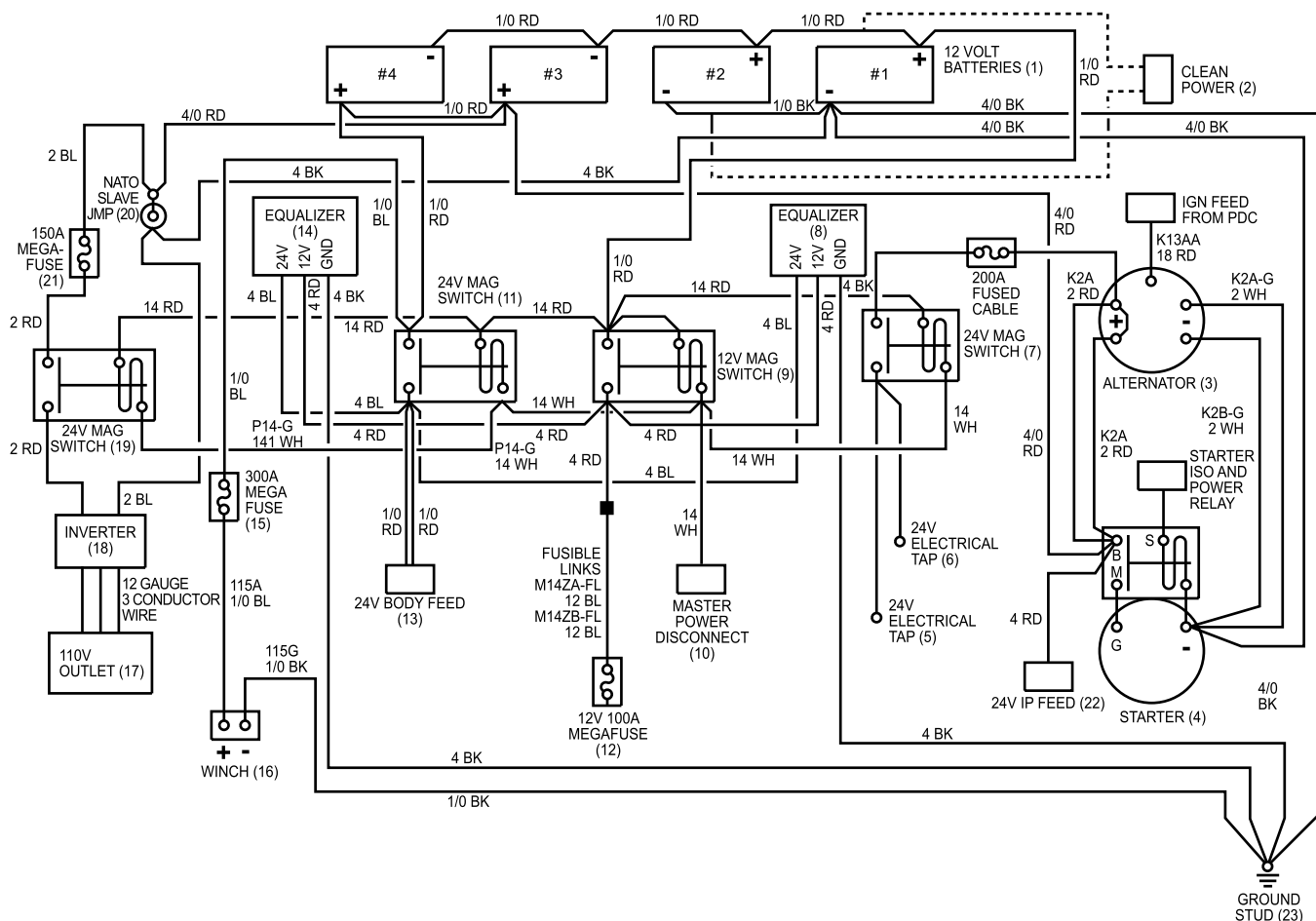

B230602290

Figure 80. Power Distribution Function Diagram.

END OF WORK PACKAGE

FIELD MAINTENANCE
CONNECTOR COMPOSITES

INITIAL SETUP:

NOT APPLICABLE

INTRODUCTION

This work package provides connector composites in alphanumeric order for all electrical circuits, electrical systems, and electronic systems covered in this technical manual.

ABBREVIATIONS

Abbreviations are in accordance with ASME Y14.38.

WIRING DIAGRAMS

POWER MIRROR SWITCH
(254M)

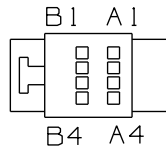

CAV	CIRCUIT	GAUGE	COLOR	TERMINAL
A1	A62D	20	DKBL	3535805C1
A2	A78L	20	LTGN	3535805C1
A3	A78K	20	LTGN	3535805C1
A4	A78-GDX	20	WH	3535805C1
B1	A78A	20	LTGN	3535805C1
B2	A78D	20	LTGN	3535805C1
B3	A78C	20	LTGN	3535805C1
B4	A78F	20	LTGN	3535805C1

CONNECTOR - 3510243C1

PANEL LIGHT ADAPTER SPLICE PACK (1002)
(LOCATED IN CENTER INSTRUMENT PANEL)



CAV	CIRCUIT	GAUGE	COLOR	TERMINAL
A	A62D	20	DKBL	1661208C1
B	A62ZB	18	DKBL	1661208C1
C	-	-	-	-
D	A62Z	16	DKBL	1661209C1
E	-	-	-	-
F	A21B	16	TN	1661209C1
G	-	-	-	-
H	A62A	18	LTGN	1661208C1
J	A62ZJ	18	DKBL	1661208C1
K	A62X	18	DKBL	1661208C1

CONNECTOR - 2007315C1
BODY LOCK - 2007316C1

Figure 1. Connector Composites (254M, 1002).

CONNECTOR COMPOSITES - (CONTINUED)

GROUND ADAPTER SPLICE PACK (1003)
(LOCATED IN CENTER INSTRUMENT PANEL)



CAV	CIR	GAUGE	COLOR	TERMINAL
A	A11-GAL	12	WH	1661211C1
B	A11-GBA	18	WH	1661208C1
C	A114-G	18	WH	1661208C1
D	A11-GN	18	WH	1661208C1
E	A11-GD	18	WH	1661208C1
F	A27-G	18	WH	1661208C1
G	A21-G	16	WH	1661209C1
H	A63-GA	16	WH	1661209C1
J	GRD-A	16	WH	1661209C1
K		-	-	-

CONNECTOR - 2007315C1
BODY LOCK - 2007316C1

ETHER START SWITCH (1010)
(LOCATED IN INSTRUMENT PANEL)

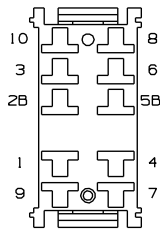

CAV	CIRCUIT	GAUGE	COLOR	TERMINAL
1	-	-	-	-
2B	A21C	16	TN	1661226C1
3	A21E	16	TN	1661226C1
4	-	-	-	-
5B	-	-	-	-
6	-	-	-	-
7	-	-	-	-
8	A21B	16	TN	1661226C1
9	-	-	-	-
10	A21-G	16	WH	1661226C1

CONNECTOR - 3520850C1

B235002802

Figure 2. Connector Composites (1003, 1010).

CONNECTOR COMPOSITES - (CONTINUED)

FUSE BLOCK #1 (1011)
LOCATED IN RIGHT SIDE INSTRUMENT PANEL

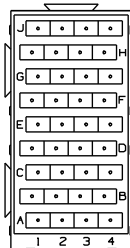

CONNECTOR - 3534572C1
BODY LOCK - 3536085C1

CAV	CIR	GAUGE	COLOR	TERM
A1	A78P	16	LTGN	3573312C1
A2	A14AS	10	RD	3536303C1
A3	H-14	10	RD	3536303C1
A4	A14AB	10	RD	3536303C1
B1	A78J	18	LTGN	3515517C1
B2	A113T	14	YL	3573312C1
B3	A86S	12	LTGN	3573311C1
B4	A86T	12	LTGN	3573311C1
C1	-	-	-	-
C2	(A14AS)	-	-	3536303C1
C3	(A14)	-	-	3536303C1
C4	(A14AB)	-	-	3536303C1
D1	-	-	-	-
D2	A92BT	18	RD	3515517C1
D3	-	-	-	-
D4	-	-	-	-
E1	A12C	10	LTBL	3536298C1
E2	(A14AS)	-	-	3536303C1
E3	(A14)	-	-	3536303C1
E4	(A14AB)	-	-	3536303C1
F1	A12P/A12N	18/18	LTBL/LTBL	3573312C1
F2	A15/A98	18/18	RD/VT	3573312C1
F3	-	-	-	-
F4	-	-	-	-
G1	(A12C)	-	-	3536298C1
G2	(A14AS)	-	-	3536303C1
G3	(A14)	-	-	3536303C1
G4	(A14AB)	-	-	3536303C1
H1	-	-	-	-
H2	A28	16	TN	3573312C1
H3	-	-	-	-
H4	-	-	-	-
J1	-	-	-	-
J2	-	-	-	-
J3	-	-	-	-
J4	-	-	-	-

LOCATION	CAVITY	RATING	PART NUMBER	PART NUMBER	DESCRIPTION
			FUSE	BREAKER	
F13	A1, B1	10 AMPS		3536178C1	RIGHT MIRROR HEAT
F5	E1, F1	5 AMPS	3534208C1	-	SYSTEM CONTROLLER/6 SW PACK
F14	A2, B2	10 AMPS		3536178C1	MVLS 12 VOLT SUPPLY
F10	C2, D2	5 AMPS	3534208C1	-	ALLISON GEN 4 SHIFTER
F6	E2, F2	5 AMPS	3534208C1	-	KEY SWITCH/DIAGNOSTIC CONN
F2	G2, H2	15 AMPS		3536179C1	INSTRUMENT CLUSTER
F15	A3, B3	30 AMPS		3536182C1	LEFT SIDE POWER SOURCE
F16	A4, B4	30 AMPS		3536182C1	RIGHT SIDE POWER SOURCE

NOTE:

CIRCUIT NUMBERS WITH PARENTHESES REPRESENT
BUSS BARS

B235002803

Figure 3. Connector Composites (1011).

CONNECTOR COMPOSITES - (CONTINUED)

FUSE BLOCK #2 (1012)
LOCATED IN RIGHT SIDE INSTRUMENT PANEL

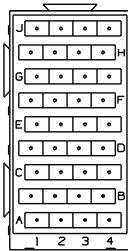

CONNECTOR - 3534572C1
BODY LOCK - 3536085C1

CAV	CIR	GAUGE	COLOR	TERM
A1	A13AJ	10	PK	3536303C1
A2	(A13AH)/A13AJ	-/10	-/PK	3515516C1
A3	B0-L	16	YL	3573312C1
A4	J56L	16	OR	3573312C1
B1	-	-	-	-
B2	A99E/A17H	16	VL/PK	3573311C1
B3	-	-	-	-
B4	-	-	-	-
C1	(A13AJ)	-	-	3536303C1
C2	(A13AH)	-	-	3515516C1
C3	J56B0	16	OR	3573312C1
C4	GRD-L	16	WH	3573312C1
D1	-	-	-	-
D2	-	-	-	-
D3	A11-GAF/A11-GAD	16/16	WH/WH	3573311C1
D4	A13AH	10	PK	3573311C1
E1	(A13AJ)	-	-	3536303C1
E2	A13AH	10	PK	3515516C1
E3	A11-GLZ	12	WH	3573311C1
E4	-	-	-	-
F1	A28A	18	TN	3515517C1
F2	A13AF	18	PK	3515517C1
F3	A14AV	10	RD	3573311C1
F4	A13AG	16	PK	3573312C1
G1	(A13AJ)	-	-	3536303C1
G2	A78M	16	LT GN	3573312C1
G3	A11-GAF	16	WH	3573312C1
G4	A12B	10	LTBL	3573311C1
H1	A921GN	18	TN	3515517C1
H2	A78H	18	LT GN	3515517C1
H3	A11-GAS	12	WH	3573311C1
H4	-	-	-	-
J1	-	-	-	-
J2	-	-	-	-
J3	A14AT	10	RD	3573311C1
J4	A12	18	LT BL	3515517C1

LOCATION	CAVITY	RATING	PART NUMBER	PART NUMBER	DESCRIPTION
			FUSE	BREAKER	
F19	E1, F1	5 AMPS	3534208C1	-	INST CLUSTER/HTR
F17	G1, H1	10 AMPS		3536178C1	ALLISON LCT/EATON AUTOSHIFT-AUTOCLUTCH
F24	A2, B2	5 AMPS	3534208C1	-	ACCELERATOR/CLUTCH SW
F20	E2, F2	5 AMPS	3534208C1	-	SYSTEM CONTROLLER/HTR - A/C BLOWER
F18	G2, H2	10 AMPS		3536178C1	LEFT MIRROR HEAT

RELAY PIN #		
85, 86, 30, 87, 87a		
CAVITY	PART NUMBER	RELAY DESCRIPTION
D3, F4, D4, F3, E3	3519350C1	IGNITION
G3, J4, G4, J3, H3	3519350C1	ACCESSORY
A3, C4, A4, C3, B3	3519350C1	STOP LIGHT LEFT

NOTE:

CIRCUIT NUMBERS WITH PARENTHESES REPRESENT
BUSS BARS

B265002804

Figure 4. Connector Composites (1012).

CONNECTOR COMPOSITES - (CONTINUED)

FUSE BLOCK #3 (1013)
LOCATED IN RIGHT SIDE INSTRUMENT PANEL

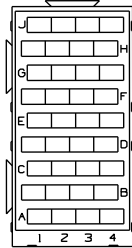

CONNECTOR - 3534572C1
BODY LOCK - 3536085C1

CAV	CIR	GAUGE	COLOR	TERM
A1	A13FB	10	PK	3515516C1
A2	(A13FA)/A13FB	-/10	-/PK	3536303C1
A3	-	-	-	-
A4	A12E	10	LT BL	3573311C1
B1	A21C	16	TN	3573312C1
B2	-	-	-	-
B3	-	-	-	-
B4	A78L	20	LT GN	3535484C1
C1	(A13FB)	-	-	3515516C1
C2	(A13FA)	-	-	3536303C1
C3	-	-	-	-
C4	-	-	-	-
D1	-	-	-	-
D2	-	-	-	-
D3	B0-R	16	YL	3573312C1
D4	J70R	16	OR	3573312C1
E1	(A13FB)	-	-	3515516C1
E2	(A13FA)	-	-	3536303C1
E3	-	-	-	-
E4	-	-	-	-
F1	A42A	18	GY	3515517C1
F2	-	-	-	-
F3	J70-L	16	OR	3573312C1
F4	GRD-R	16	WH	3573312C1
G1	-	-	-	-
G2	A13FA	10	PK	3536303C1
G3	A11-GBA	18	WH	3515517C1
G4	A14FJ	10	RD	3573311C1
H1	-	-	-	-
H2	-	-	-	-
H3	-	-	-	-
H4	-	-	-	-
J1	-	-	-	-
J2	-	-	-	-
J3	A13FA	10	PK	3573311C1
J4	A13DB	18	PK	3515517C1

LOCATION	CAVITY	RATING	PART NUMBER	PART NUMBER	DESCRIPTION
			FUSE	BREAKER	
F33	A1, B1	10 AMPS		3536178C1	ETHER START
F29	E1, F1	5 AMPS	3534208C1	-	OPT WARNING LTS
F36	A4, B4	5 AMPS	3534208C1	-	POWER MIRROR

RELAY PIN #		
85, 86, 30, 87, 87a	-	-
CAVITY	PART NUMBER	RELAY DESCRIPTION
D3, F4, D4, F3, E3	3519350C1	STOP LIGHT RIGHT
G3, J4, G4, J3, H3	3519350C1	IGNITION

NOTE:
CIRCUIT NUMBERS WITH PARENTHESES REPRESENT BUSS BARS

B235002805

Figure 5. Connector Composites (1013).

CONNECTOR COMPOSITES - (CONTINUED)

FUSE BLOCK #4 (1014)
LOCATED IN RIGHT SIDE INSTRUMENT PANEL

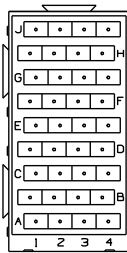

CONNECTOR - 3534572C1
BODY LOCK - 3536085C1

CAV	CIR	GAUGE	COLOR	TERM
A1	A16B	10	RD	3536303C1
A2	A16A	10	RD	3536303C1
A3	A16BB	10	RD	3536303C1
A4	A75A	18	LTGN	3515517C1
B1	A63V	16	DKBL	3573312C1
B2	A75KA	16	LTGN	3573312C1
B3	A75KB	16	LTGN	3573312C1
B4	A75R	18	LTGN	3515517C1
C1	(A16B)	-	-	3536303C1
C2	(A16A)	-	-	3536303C1
C3	-	-	-	-
C4	-	-	-	-
D1	-	-	-	-
D2	-	-	-	-
D3	A11-GD/A11-GAM	18/18	WH/WH	3573312C1
D4	A78VA	14	LTGN	3573312C1
E1	(A16B)	-	-	3536303C1
E2	(A16A)	-	-	3536303C1
E3	-	-	-	-
E4	-	-	-	-
F1	A64VA	16	YL	3673312C1
F2	A78VA	14	LTGN	3573312C1
F3	A78WBA	14	LTGN	3573312C1
F4	A78WA/A78WB	18/18	LTGN/LTGN	3573312C1
G1	(A16B)/A16BB	-/10	-/RD	3536303C1
G2	(A16A)	-	-	3536303C1
G3	A11-GAM	18	WH	3515517C1
G4	A78VB	14	LTGN	3573312C1
H1	A114A	18	YL	3515517C1
H2	A78VB	14	LTGN	3573312C1
H3	-	-	-	-
H4	-	-	-	-
J1	-	-	-	-
J2	-	-	-	-
J3	A78WBB	14	LTGN	3573312C1
J4	A78WB	18	LTGN	3515517C1

LOCATION	CAVITY	RATING	PART NUMBER	PART NUMBER	DESCRIPTION
			FUSE	BREAKER	
F43	A1, B1	10 AMPS		3536178C1	DOME LIGHT 24 VOLT
F39	E1, F1	10 AMPS		3536178C1	SPOT LIGHT 24 VOLT
F37	G1, H1	10 AMPS		3536178C1	IR LIGHT 24 VOLT
F44	A2, B2	20 AMPS		3536180C1	LEFT AC CONDENSER FAN
F40	E2, F2	20 AMPS		3536180C1	RIGHT HEATED WINDSHIELD 24 VOLT
F38	G2, H2	20 AMPS		3536180C1	LEFT HEATED WINDSHIELD 24 VOLT
F45	A3, B3	20 AMPS		3536180C1	RIGHT AC CONDENSER FAN
F46	A4, B4	5 AMPS	3534208C1	-	FUEL FIRED HEATER 24 VOLT

RELAY PIN #		
85, 86, 30, 87, 87a		
CAVITY	PART NUMBER	RELAY DESCRIPTION
D3, F4, D4, F3, E3	3519350C1	RIGHT HEATED WINDSHIELD
G3, J4, G4, J3, H3	3519350C1	LEFT HEATED WINDSHIELD

NOTE:

CIRCUIT NUMBERS WITH PARENTHESES REPRESENT BUSS BARS

B235002806

Figure 6. Connector Composites (1014).

CONNECTOR COMPOSITES - (CONTINUED)

LEFT BLOWER MOTOR RELAY (1018)

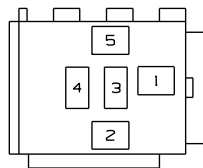

CONNECTOR - 0593385C1
BODY LOCK - 0593387C1

CAV	CIRCUIT	GAUGE	COLOR	TERMINAL
1	A75KA	16	LTGN	1661709C1
2	A75KD	18	LTGN	1659673C1
3	-	-	-	-
4	A75KK	18	LTGN	1659673C1
5	A75KH	18	LTGN	1659673C1

RIGHT BLOWER MOTOR RELAY (1019)

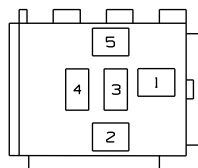

CONNECTOR - 0593385C1
BODY LOCK - 0593387C1

CAV	CIRCUIT	GAUGE	COLOR	TERMINAL
1	A75KB	16	LTGN	1661709C1
2	A75KE	18	LTGN	1659673C1
3	-	-	-	-
4	A75KL	18	LTGN	1659673C1
5	A75KJ	18	LTGN	1659673C1

BLACKOUT MODE SPLICE PACK (1050)



CONNECTOR - 2007315C1
BODY LOCK - 2007316C1

CAV	CIRCUIT	GAUGE	COLOR	TERMINAL
A	A113R	16	YL	1661209C1
B	A56AZ	18	OR	1661208C1
C	A57AZ	18	OR	1661208C1
D	BO-1	18	YL	1661208C1
E	-	-	-	-
F	-	-	-	-
G	-	-	-	-
H	A113	16	YL	1661209C1
J	A113S	18	YL	1661208C1
K	-	-	-	-

24 VOLT INPUT (1051)

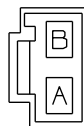

CONNECTOR - 1661197C1

CAV	CIRCUIT	GAUGE	COLOR	TERMINAL
A	A16A	10	RD	1661214C2
B	A16B	10	RD	1661214C2

B235002807

Figure 7. Connector Composites (1018, 1019, 1050, 1051).

CONNECTOR COMPOSITES - (CONTINUED)

MVLS GROUND
(1052)

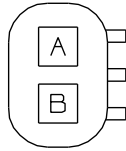

CONNECTOR - 1671611C1
BODY LOCK - 1671608C1
PLUG - 0587579C1

CAV	CIRCUIT	GAUGE	COLOR	TERMINAL	SEAL
A	PLUG	-	-	-	-
B	A11-GMM	14	WH	2033912C1	0589391C1

GROUND SPLICE PACK
(1053)



CAV	CIRCUIT	GAUGE	COLOR	TERMINAL
A	A11-GEA	12	WH	3566715C1
B	A58AC-G	14	WH	3566715C1
C	A11-GMM	18	WH	3566715C1
D	A11-GDY	18	WH	1661208C1
E	A64-GA	16	WH	1661209C1
F	A56-GA	16	OR	1661209C1
G	A57-GA	16	OR	1661209C1
H	-	-	-	-
J	-	-	-	-
K	-	-	-	-

CONNECTOR - 2007315C1
BODY LOCK - 2007316C1

NEG STUD
(1054)

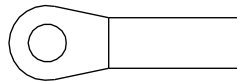

CIRCUIT	GAUGE	COLOR	TERMINAL	SLEEVE
A11-GEA	12	WH	2020632C1	2644002R1

GROUND TERMINAL
(1055)

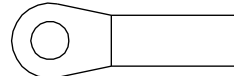

CIRCUIT	GAUGE	COLOR	TERMINAL	SLEEVE
A75-GK	12	WH	0365684C2	2643648R1

KEY SWITCH
(1100M)

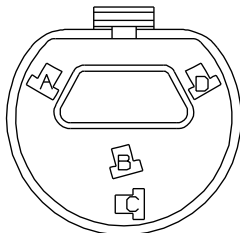

CONNECTOR - 3546518C1
BODY LOCK - 3546519C1

CAV	CIRCUIT	GAUGE	COLOR	TERMINAL
A	A15	18	RD	1661209C1
B	A17	18	PK	1661209C1
C	A12	18	LTBL	161209C1
D	A13DD	18	PK	161209C1

SWITCH PACK CONNECTOR
(1101M)

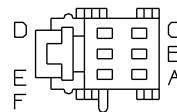

CONNECTOR - 2031871C1
BODY LOCK - 2031873C1

CAV	CIRCUIT	GAUGE	COLOR	TERMINAL
A	A11-GDB	18	WH	1661261C1
B	A12P	18	LTBL	1661261C1
C	A62C	18	DKBL	1661261C1
D	A3E(+)	20	DKBL	3544254C1
E	A3F(-)	20	GY	3544254C1
F	-	-	-	-

B235002808

Figure 8. Connector Composites (1052, 1053, 1054, 1055, 1100M, 1101M).

CONNECTOR COMPOSITES - (CONTINUED)

DOME LAMP SWITCH
(1111)



CONNECTOR - 1661889C1
BODY LOCK - 1661809C1

CAV	CIRCUIT	GAUGE	COLOR	TERMINAL
A	A63VA	16	DKBL	1661261C1
B	A63AB	16	DKBL	1661261C1
C	A63AA	16	DKBL	1661261C1

HEATER INTERRUPT SWITCH
(1112)



CONNECTOR - 1661259C1
BODY LOCK - 1661263C1

CAV	CIRCUIT	GAUGE	COLOR	TERMINAL
A	A75B	18	LTGN	1661261C1
B	A75BB	18	LTGN	1661261C1

DISCONNECT MASTER POWER SWITCH
(1150)



CONNECTOR - 1661259C1
BODY LOCK - 1661263C1

CAV	CIRCUIT	GAUGE	COLOR	TERMINAL
A	A11-GM	18	WH	1661261C1
B	A11-GN	18	WH	1661261C1

HVAC INTERCONNECT
(BLACK) (1250)

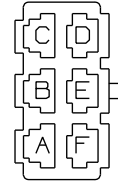

CONNECTOR - 0892136C1

CAV	CIRCUIT	GAUGE	COLOR	TERMINAL
A	A75KC	18	LTGN	0879630C1
B	A75KF	18	LTGN	0879630C1
C	A75KK	18	LTGN	0879630C1
D	A75KL	18	LTGN	0879630C1
E	A75-GKA	14	WH	0188396R1
F	A75-GKB	14	WH	0188396R1

CLUSTER CONN
(1500)

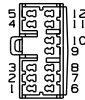

CONNECTOR - 2018590C1

CAV	CIR	GAUGE	COLOR	TERM
1	A62	16	DKBL	2018639C1
2	-	-	-	-
3	A28	16	TN	2018639C1
4	A5AL(+)	18	YL	2018639C1
5	A5AM(-)	18	GN	2018639C1
6	-	-	-	-
7	A28-G	18	WH	2018639C1
8	A28A	18	TN	2018639C1
9	A50	20	YL	2018639C1
10	-	-	-	-
11	-	-	-	-
12	-	-	-	-

EGC BLACKOUT
(1520)



CONNECTOR - 1667529C1
BODY LOCK - 1667530C1

CAV	CIRCUIT	GAUGE	COLOR	TERMINAL
A	A53BC	18	YL	1661262C1
B	A68B	18	BN	1661262C1
C	A113S	18	YL	1661262C1
D	-	-	-	-

B235002809

Figure 9. Connector Composites (1111, 1112, 1150, 1250, 1500, 1520).

CONNECTOR COMPOSITES - (CONTINUED)

24 VOLT METER
(1521)



CONNECTOR - 1667305C1
BODY LOCK - 1661263C1

CAV	CIRCUIT	GAUGE	COLOR	TERMINAL
A	A13AB	18	PK	1661261C1
B	A27-GB	18	WH	1661261C1
C	A27-GA	18	WH	1661261C1
D	A62ZB	18	DKBL	1661261C1

OPT. WARNING LIGHT CONN (BLK)
(1555M)

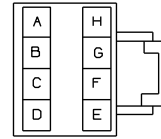

CONNECTOR: 2005835C1
BODY LOCK: 2006503C1

CAV	CIRCUIT	GAUGE	COLOR	TERMINAL
C	A42	18	GY	1661208C1
F	A42A	18	GY	1661208C1

ELECTRICAL SYSTEM CONTROLLER (ESC) GRAY
(1600)

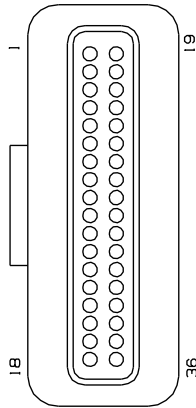

CONNECTOR ASSY: 3533832C1
CONNECTOR: 3533834C1
RETAINER: 3533833C1
SEAL: 3533835C1
CPA: 3533836C1
STRAIN RELIEF: 3533832C1
PLUG: 3518314C1

CAV	CIR	GAUGE	COLOR	TERM
1	A11-GAB	20	WH	3533507C1
2	A12N	18	LTBL	3517243C1
3	A9H	18	GY	3517243C1
5	A85C	20	GY	3533507C1
10	A96	20	VT	3533507C1
12	A13AF	18	PK	3517243C1
13	A85B	20	GY	3533507C1
14	A50	20	YL	3533507C1
15	A40	20	GY	3533507C1
16	A40A	20	GY	3533507C1
17	A96A	20	VT	3533507C1
18	A57A	18	OR	3517243C1
19	A56A	18	OR	3517243C1
20	A52A	20	YL	3533507C1
21	A102	18	YL	3517243C1
22	A82	20	GY	3533507C1
23	A82A	20	GY	3533507C1
24	A82B	20	GY	3533507C1
27	A6H	20	GY	3533507C1
28	A87A	20	GY	3533507C1
29	A3E (+)	20	DKBL	3533507C1
30	A3F (-)	20	GY	3533507C1
32	A44BB	20	GY	3533507C1
33	A70C	20	RD	3533507C1
34	A5AN (+)	18	YL	3517243C1
35	A5AP (-)	18	GN	3517243C1

NOTE:
CAVITIES NOT LISTED HAVE PLUGS

ELECTRICAL SYSTEM CONTROLLER (ESC) BROWN
(1601)

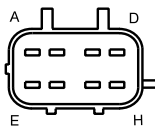

CONNECTOR: 3548934C1
BODY LOCK: 3548943C1
SECOND LOCK: 3573833C1
PLUG: 2025431C1

CAV	CIRCUIT	GAUGE	COLOR	TERMINAL	SEAL
B	A11-GAH	14	WH	3535931C1	3548945C1
G	A7B	14	LTGN	3535931C1	3548945C1

NOTE:
CAVITIES NOT LISTED HAVE PLUGS

B235002810

Figure 10. Connector Composites (1521, 1555M, 1600, 1601).

CONNECTOR COMPOSITES - (CONTINUED)

DIAGNOSTIC CONN
(1650)

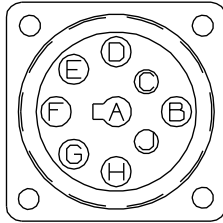

CAV	CIRCUIT	GAUGE	COLOR	TERMINAL
A	A9B-G	18	WH	1651968C1
B	A9B	18	VT	1651968C1
C	A5AE (+)	18	YL	1651968C1
D	A5AF (-)	18	GN	1651968C1
F	A3B (+)	16	DKBL	1651968C1
G	A3B (-)	16	GY	1651968C1

CONNECTOR - 3544066C1

J1939 TELEMATICS
(1658)

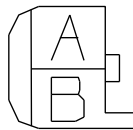

CAV	CIR	GAUGE	COLOR	TERM
A	A5BE (+)	18	YL	1661261C1
B	A5BF (-)	18	GN	1661261C1

CONNECTOR - 1661259C1
BODY LOCK - 1661263C1

B235002811

Figure 11. Connector Composites (1650, 1658).

CONNECTOR COMPOSITES - (CONTINUED)

(1P) PASS THROUGH
(1701)

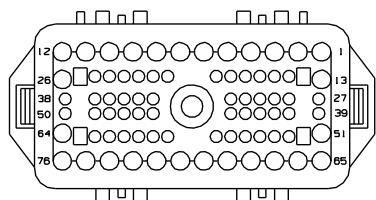

CONNECTOR ASSY - 3595625C1

CAV	CIRCUIT	GAUGE	COLOR	TERM
1	A99V	16	VT	3574288C1
2	A97Y	16	VT	3574288C1
3	-	-	-	-
4	A99U	16	VT	3574288C1
5	A97P	16	VT	3574288C1
6	-	-	-	-
7	A97Q	16	VT	3574288C1
8	A17	16	PK	3574288C1
9	-	-	-	-
10	-	-	-	-
11	A13C	18	PK	3574289C1
12	-	-	-	-
13	-	-	-	-
14	A11-GM	18	WH	2003343C1
15	A5B(+)	18	YL	2003343C1
16	A5B(-)	18	GN	2003343C1
17	-	-	-	-
18	-	-	-	-
19	-	-	-	-
20	-	-	-	-
21	A58AC	14	BN	3574285C1
22	-	-	-	-
23	-	-	-	-
24	A113B	16	YL	3574285C1
25	A113C	16	YL	3574285C1
26	-	-	-	-
27	A113	16	YL	3574285C1
28	-	-	-	-
29	A21E	16	TN	3574285C1
30	A87BA	18	GY	2003343C1
31	-	-	-	-
32	A42	18	GY	2003343C1
33	A94AA	16	GY	3574285C1
34	A94AB	16	GY	3574285C1
35	-	-	-	-
36	A92#134	18	YL	2003343C1
37	A113A	18	YL	2003343C1
38	A114	18	YL	2003343C1
39	A13AB	18	PK	2003343C1
40	A3A(+)	18	DKBL	2003343C1

CAV	CIRCUIT	GAUGE	COLOR	TERM
41	A3A(-)	18	GY	2003343C1
42	A94AK	16	GY	3574285C1
43	A94AL	16	GY	3574285C1
44	-	-	-	-
45	A75C	18	LTGN	2003343C1
46	A75A	18	LTGN	2003343C1
47	A75D	18	LTGN	2003343C1
48	A75B	18	LTGN	2003343C1
49	A94AM	18	GY	2003343C1
50	A94AN	18	GY	2003343C1
51	A94AT	16	GY	3574288C1
52	A94AS	18	GY	2003343C1
53	A94AP	18	GY	2003343C1
54	A94AR	18	GY	2003343C1
55	A94AX	18	GY	2003343C1
56	A94AW	18	GY	2003343C1
57	A94AV	18	GY	2003343C1
58	A94AH	18	GY	2003343C1
59	A94AF	18	GY	2003343C1
60	A94AJ	18	GY	2003343C1
61	A94AE	18	GY	2003343C1
62	A94AD	18	GY	2003343C1
63	A94AC	18	GY	2003343C1
64	-	-	-	-
65	A94AU	16	GY	3574288C1
66	-	-	-	-
67	-	-	-	-
68	-	-	-	-
69	-	-	-	-
70	-	-	-	-
71	-	-	-	-
72	-	-	-	-
73	-	-	-	-
74	A94AY	12	GY	3574287C1
75	A94AYA	16	GY	3574288C1
76	-	-	-	-
77	-	-	-	-
78	J58-3	12	BN	

B235002812

Figure 12. Connector Composites (1701).

CONNECTOR COMPOSITES - (CONTINUED)

(DASH) PASS THROUGH
(1701)

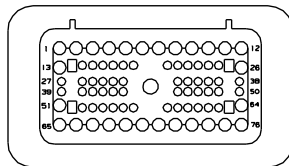

CONNECTOR ASSY - 3595624C1
 LARGE PLUG - 3598922C1 CAVITIES 1-13, 26, 51 & 64-76
 SMALL PLUG - 3598921C1 ALL OTHER CAVITIES

CAV	CIRCUIT	GAUGE	COLOR	TERMINAL
1	J99V	16	VT	3549416C1
2	J99Y	16	VT	3549416C1
3	PLUG	-	-	-
4	J99U	16	VT	3549416C1
5	J97P	16	VT	3549416C1
6	PLUG	-	-	-
7	J97Q	16	VT	3549416C1
8	J17	16	PK	3549416C1
9	PLUG	-	-	-
10	PLUG	-	-	-
11	J13C	16	PK	3549416C1
12	PLUG	-	-	-
13	PLUG	-	-	-
14	J11-GM	16	WH	3549417C1
15	J5B(+)	18	YL	3549418C1
16	J5B(-)	18	GN	3549418C1
17	PLUG	-	-	-
18	PLUG	-	-	-
19	PLUG	-	-	-
20	PLUG	-	-	-
21	J58AC	16	BN	3549417C1
22	PLUG	-	-	-
23	PLUG	-	-	-
24	J113B	14	YL	3549417C1
25	J113C	14	YL	3549417C1
26	PLUG	-	-	-
27	J113	16	YL	3549417C1
28	PLUG	-	-	-
29	J21E	18	TN	3549418C1
30	J87BA	18	GY	3549418C1
31	PLUG	-	-	-
32	J42	18	GY	3549418C1
33	J94AA	18	OR	3549418C1
34	J94AB	18	GY	3549418C1
35	J70JA	18	OR	-
36	J92#134	18	YL	3549418C1
37	J113A	16	YL	3549417C1
38	J114	16	YL	3549417C1
39	J13AB	18	PK	3549418C1
40	J3A(+)	18	DKBL	3549418C1

CAV	CIRCUIT	GAUGE	COLOR	TERMINAL
41	J3A(-)	18	GY	3549418C1
42	J94AK	18	YL	3549418C1
43	J94AL	18	DKBL	3549418C1
44	PLUG	-	-	-
45	J75C	16	LTGN	3549417C1
46	J75A	16	LTGN	3549417C1
47	J75D	16	LTGN	3549417C1
48	J75B	16	LTGN	3549417C1
49	J94AM	18	GY	3549418C1
50	J94AN	18	GY	3549418C1
51	J94AT	16	GY	3549416C1
52	J94AS	18	GY	3549418C1
53	J94AP	18	GY	3549418C1
54	J94AR	18	GY	3549418C1
55	J94AX	18	GY	3549418C1
56	J94AW	18	GY	3549418C1
57	J94AV	18	GY	3549418C1
58	J94AH	18	LTGN	3549418C1
59	J94AF	18	VT	3549418C1
60	J94AJ	18	LTBL	3549418C1
61	J94AE	18	BN	3549418C1
62	J94AD	18	RD	3549418C1
63	J94AC	18	BK	3549418C1
64	PLUG	-	-	-
65	J94AU	16	GY	3549416C1
66	PLUG	-	-	-
67	PLUG	-	-	-
68	PLUG	-	-	-
69	PLUG	-	-	-
70	PLUG	-	-	-
71	PLUG	-	-	-
72	PLUG	-	-	-
73	PLUG	-	-	-
74	J94AY	12	GY	3549415C1
75	A94AYA	16	GY	3549416C1
76	PLUG	-	-	-
77	-	-	-	-
78	J58-4	12	BN	-

B235002813

Figure 13. Connector Composites (1701).

CONNECTOR COMPOSITES - (CONTINUED)

STOP / TURN LIGHT
(1703F)

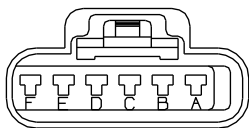

CONNECTOR - 3550639C1

CAV	CIRCUIT	GAUGE	COLOR	TERMINAL
A	A70J	16	OR	3544880C1
B	A70	16	OR	3544880C1
C	A56	16	OR	3544880C1
D	A56J	16	OR	3544880C1
E	-	-	-	-
F	-	-	-	-

STOP / TURN LIGHT
(1703M)

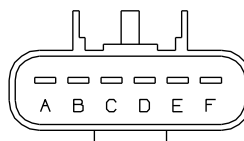

CONNECTOR - 3550638C1

CAV	CIRCUIT	GAUGE	COLOR	TERMINAL
A	J70JR	16	OR	3544876C1
B	J70	16	OR	3544876C1
C	J56	16	OR	3544876C1
D	J56J	16	OR	3544876C1
E	-	-	-	-
F	-	-	-	-

MATES WITH

CAB / DCM
(1800)

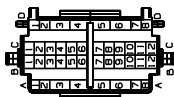

NOTE:
MATES WITH CONNECTOR (1805)

CONNECTOR: 3553649C1
 BODY LOCK: 3553650C1
 150 SERIES TERMINAL: 3544883C1 (20 AWG)
 3544884C1 (18 AWG)
 280 SERIES TERMINAL: 3544875C1 (20 AWG)
 3544876C1 (18 AWG)

CAV	CIRCUIT	GAUGE	COLOR	TERMINAL
A1	A56AY	18	OR	3517243C1
A2	A57AY	18	OR	3544884C1
A3	A11-GAA	18	WH	3544876C1
A4	A9H	18	GY	3544876C1
A5	A87C	20	GY	3544875C1
A7	A52A	20	YL	3544883C1
A8	A102I	18	YL	3544884C1
B1	A82B	20	GY	3544883C1
B2	A40A	20	GY	3544883C1
B3	A6H	20	GY	3544883C1
B4	A97Y	16	VT	3544884C1
B5	A99U	16	VT	3544884C1
B7	A44BB	20	GY	3544883C1
B9	A70C	20	RD	3544883C1
B10	A85B	20	GY	3544883C1
B11	A85C	20	GY	3544883C1
B12	A96	20	VT	3544883C1
C1	A82A	20	GY	3544883C1
C4	A99V	16	VT	3544884C1
C5	A97P	16	VT	3544884C1
C6	A99E	16	VT	3544884C1
C9	A82	20	GY	3544883C1
C10	A97Q	16	VT	3544884C1
C11	A96A	20	VT	3544883C1
C12	A40	20	GY	3544883C1
D8	A17H	16	PK	3553649C1

ACCELERATOR PEDAL
ACCELERATOR POSITION SENSOR (APS)
AND IDLE VALIDATION SWITCH (IVS)
(1804)



CONNECTOR: 1687790C1
 TERMINAL: 1651943C1 (18 AWG)

CAV	CIRCUIT	GAUGE	COLOR	TERMINAL
A	B99V	18	VT	1651943C1
B	B97AD	18	VT	1651943C1
C	B97AF	18	VT	1651943C1
D	B99U	18	VT	1651943C1
E	B99W	18	VT	1651943C1
F	B99E	18	VT	1651943C1

B235002814

Figure 14. Connector Composites (1703F, 1703M, 1800, 1804).

CONNECTOR COMPOSITES - (CONTINUED)

DCM / CAB
(1805)

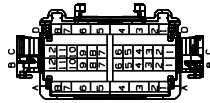

NOTE:
MATES WITH CONNECTOR (1800)

CONNECTOR: 3553651C1
BODY LOCK: 3553652C1
STABILIZER: 3553653C1
LEVER LOCK: 3553654C1
TERMINAL: 3544886C1
(18 AWG)

CAV	CIRCUIT	GAUGE	COLOR	TERMINAL
A1	B56A	18	OR	3544886C1
A2	B57A	18	OR	3544886C1
A3	B11-GAA	18	WH	3544880C1
A4	B9V	18	GY	3544880C1
A5	B87A	18	GY	3544880C1
A7	B52A	18	YL	3544886C1
A8	B102A	18	YL	3544886C1
B1	B82B	18	GY	3544886C1
B2	B40A	18	GY	3544886C1
B3	B6H	18	GY	3544886C1
B4	B97Y	18	VT	3544886C1
B5	B99U	18	VT	3544886C1
B6	B99W	18	VT	3544886C1
B7	B44BB	18	GY	3544886C1
B9	B70C	18	OR	3544886C1
B10	B85B	18	GY	3544886C1
B11	B85C	18	GY	3544886C1
B12	B96	18	VT	3544886C1
C1	B82A	18	GY	3544886C1
C2	B40F	18	GY	3544886C1
C4	B99V	18	VT	3544886C1
C5	B97P	18	VT	3544886C1
C6	B99E	18	VT	3544886C1
C9	B82	18	GY	3544886C1
C10	B97Q	18	VT	3544886C1
C11	B96A	18	VT	3544886C1
C12	B40	18	GY	3544886C1
D7	B17J	18	PK	3544886C1
D8	B17H	18	PK	3544886C1

BAP SENSOR
(1808)



CONNECTOR: 2016703C1
BODY LOCK: 2016704C1
TERMINAL: 2003343C1
(18 AWG)

CAV	CIRCUIT	GAUGE	COLOR
1	B97AE	18	VT
2	B97AH	18	VT
3	B97Q	18	VT

CLOCKSPRING
(1809)

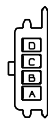

CONNECTOR: 3547870C1
TERMINAL: 1661261C1
(18 AWG)

CAV	CIRCUIT	GAUGE	COLOR
A	B9R	18	GY
B	B96	18	VT
C	B85C	18	GY
D	B85B	18	GY

MULTIFUNCTION SWITCH CONNECTOR
(1810)

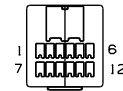

CONNECTOR: 3539212C1
TERMINAL: 3539213C1
(18 AWG)

CAV	CIRCUIT	GAUGE	COLOR
1	B56A	18	OR
2	B57A	18	OR
3	B52A	18	YL
4	B102A	18	YL
5	B82B	18	GY
6	B11-GAA	18	WH
7	B95	18	GY
8	B82	18	GY
9	-	-	-
10	-	-	-
11	B82A	18	GY
12	B87A	18	GY

PRIMARY AIR TRANSDUCER
(1811)



CONNECTOR: 1678137C1
TERMINAL: 1651934C1
(18 AWG)

CAV	CIRCUIT	GAUGE	COLOR
A	B9VC	18	GY
B	B6HB	18	GY
C	B40	18	GY

SECONDARY AIR TRANSDUCER
(1812)



CONNECTOR: 1678137C1
TERMINAL: 1651934C1
(18 AWG)

CAV	CIRCUIT	GAUGE	COLOR
A	B9VE	18	GY
B	B6HA	18	GY
C	B40A	18	GY

PARK BRAKE
(1813)



CONNECTOR: 1661777C1
BODY LOCK: 1661873C1
SEAL: 1661872C1
TERMINAL: 1661875C1
(18 AWG)

CAV	CIRCUIT	GAUGE	COLOR
C	B44BB	18	GY
D	B9VD	18	GY

B235002815

Figure 15. Connector Composites (1805, 1808, 1809, 1810, 1811, 1812, 1813).

CONNECTOR COMPOSITES - (CONTINUED)

AIR APPLICATION
TRANSDUCER
(1822)



CONNECTOR: 1678137C1
TERMINAL: 1651943C1
(18 AWG)

CAV	CIRCUIT	GAUGE	COLOR
A	B9VF	18	GY
B	B6HC	18	GY
C	B40F	18	GY

STOP LIGHT #1
(1823)



CONNECTOR: 1661777C1
SEAL: 1661872C1
TERMINAL: 1661875C1
(18 AWG)

CAV	CIRCUIT	GAUGE	COLOR
C	B70CA	18	OR
D	B9VG	18	GY

STOP LIGHT #2
(1824)



CONNECTOR: 1661777C1
SEAL: 1661872C1
TERMINAL: 1661875C1
(18 AWG)

CAV	CIRCUIT	GAUGE	COLOR
C	B70CB	18	OR
D	B9VH	18	GY

BATTERY FEED MEGA-FUSE TO CAB
(1850)

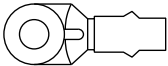

CIRCUIT	GAUGE	COLOR	TERMINAL
A14AA	6	RD	2015884C1

NEG STUD
(1851)



CIRCUIT	GAUGE	COLOR	TERMINAL
A11-GA	10	WH	0373756C2

WTEC SHIFTER 16 WAY
(1852)
(LOCATED IN IP HARNESS)

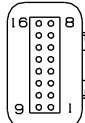

CONNECTOR: 3605446C91
PLUG: 3518314C1

CAV	CIRCUIT	GAUGE	COLOR	TERMINAL
1	PLUG	-	-	-
2	PLUG	-	-	-
3	A62A	18	LT GN	3517243C1
4	PLUG	-	-	-
5	A92-G	18	WH	3517243C1
6	PLUG	-	-	-
7	PLUG	-	-	-
8	A5AV(+)	18	YL	3517243C1
9	PLUG	-	-	-
10	PLUG	-	-	-
11	A92#134	18	YL	3517243C1
12	A921GN	18	TN	3517243C1
13	A92BT	18	RD	3517243C1
14	PLUG	-	-	-
15	A5AV(-)	18	GN	3517243C1
16	PLUG	-	-	-

NEG STUD
(1852B)



CIRCUIT	GAUGE	COLOR	TERMINAL
A11-G	10	WH	0365684C2

NEG STUD
(1862)

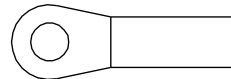

CIRCUIT	GAUGE	COLOR	TERMINAL	SLEEVE
A11-GAL	12	WH	3581768C1	-
A94-GA	12	GY	2020632C1	Z644002R1
A94-GB	14	GY	2020632C1	Z644002R1
A92-G	18	WH	3549254C1	-
A78-GM	14	WH	2020632C1	Z644005R1
A78-GN	14	WH	2020632C1	Z644005R1

NOTE:
MERGED CELLS INDICATE TWO
CIRCUITS IN ONE RING TERMINAL

B235002816

Figure 16. Connector Composites (1822, 1823, 1824, 1850, 1851, 1852, 1852B, 1862).

CONNECTOR COMPOSITES - (CONTINUED)

LEFT TURN RELAY (1876)

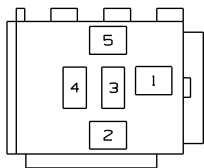

CONNECTOR - 0593385C1
BODY LOCK - 0593387C1

CAV	CIRCUIT	GAUGE	COLOR	TERMINAL
1	A56A	16	OR	1659673C1
2	A56-GA	16	OR	2018946C1
3	-	-	-	-
4	A56AY	18	OR	1659673C1
5	A56AZ	18	OR	1659673C1

RIGHT TURN RELAY (1877)

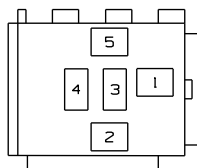

CONNECTOR - 0593385C1
BODY LOCK - 0593387C1

CAV	CIRCUIT	GAUGE	COLOR	TERMINAL
1	A57A	18	OR	3517243C1
2	A57-GA	16	OR	2018946C1
3	-	-	-	-
4	A57AY	18	OR	1659673C1
5	A57AZ	18	OR	1659673C1

FLASH TO PASS RELAY (1878)

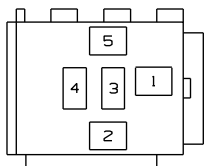

CONNECTOR - 0593385C1
BODY LOCK - 0593387C1

CAV	CIRCUIT	GAUGE	COLOR	TERMINAL
1	A102A	18	YL	3544884C1
2	GRD-1	18	WH	3544884C1
3	-	-	-	-
4	102A1	18	YL	3544884C1
5	FTP-1	18	YL	3544884C1

POWER SOCKET GROUND (1936)

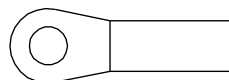

CIRCUIT	GAUGE	COLOR	TERMINAL	SLEEVE
A86-GS	12	WH	2020632C1	2644002R1

LEFT SIDE POWER SOCKET (1937)



CONNECTOR - 1661196C1

CAV	CIRCUIT	GAUGE	COLOR	TERMINAL
A	A86S	12	LT GN	3566715C1
B	A86-GS	12	WH	3566715C1

RIGHT SIDE POWER SOCKET (1938)



CONNECTOR - 1661197C1

CAV	CIRCUIT	GAUGE	COLOR	TERMINAL
A	A86T	12	LT GN	3534167C1
B	A86-GT	12	WH	3534167C1

B235002817

Figure 17. Connector Composites (1876, 1877, 1878, 1936, 1937, 1938).

CONNECTOR COMPOSITES - (CONTINUED)

LEFT HEATED WINDSHIELD
(1939)



CONNECTOR - 1684261C1
BODY LOCK - 1684263C1

CAV	CIRCUIT	GAUGE	COLOR	TERMINAL
1	A78WBB	14	LT GN	2034787C1
2	A78-GM	14	WH	2034787C1

RIGHT HEATED WINDSHIELD
(1940)



CONNECTOR - 1684261C1
BODY LOCK - 1684263C1

CAV	CIRCUIT	GAUGE	COLOR	TERMINAL
1	A78WBA	14	LT GN	2034787C1
2	A78-GN	14	WH	2034787C1

FUEL FIRED HEATER
(1951)

12 11 10

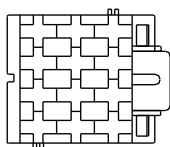

CONNECTOR - 3596927C1

3 2 1

CAV	CIRCUIT	GAUGE	COLOR	TERMINAL
1	A62ZJ	18	DK BL	3598072C1
2	A75BB	18	LT GN	3598072C1
4	A75CA	18	LT GN	3598072C1
8	A75D	18	LT GN	3598072C1
11	A75R	18	LT GN	3598072C1
12	A75CB	18	LT GN	3598072C1

INFRARED LAMP SWITCH
(1952)



CONNECTOR - 1667529C1
BODY LOCK - 1667530C1

CAV	CIRCUIT	GAUGE	COLOR	TERMINAL
A	A114A	18	YL	1661262C1
B	A114-G	18	WH	1661262C1
C	A114	18	YL	1661262C1
D	-	-	-	-

SPOT LIGHT
(1953)

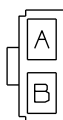

CONNECTOR - 1661196C1

CAV	CIRCUIT	GAUGE	COLOR	TERMINAL
A	A64VA	16	YL	1661209C1
B	A64-GA	16	WH	1661209C1

MVLS LIGHT SWITCH
(1954)

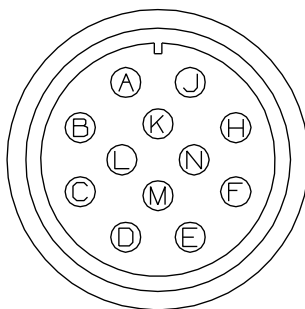

CONNECTOR - 3820120C1

CAV	CIRCUIT	GAUGE	COLOR	TERMINAL
A	-	-	-	-
B	A62Z	16	DK BL	INCLUDED
C	-	-	-	-
D	A113A	18	YL	INCLUDED
E	A113B	16	YL	INCLUDED
F	A113T	14	YL	INCLUDED
G	-	-	-	-
H	A68B	18	BN	INCLUDED
J	A113R	16	YL	INCLUDED
K	A70JA	18	OR	INCLUDED
L	-	-	-	-
M	A53BC	18	YL	INCLUDED
N	A113C	16	YL	INCLUDED

B235002818

Figure 18. Connector Composites (1939, 1940, 1951, 1952, 1953, 1954).

CONNECTOR COMPOSITES - (CONTINUED)

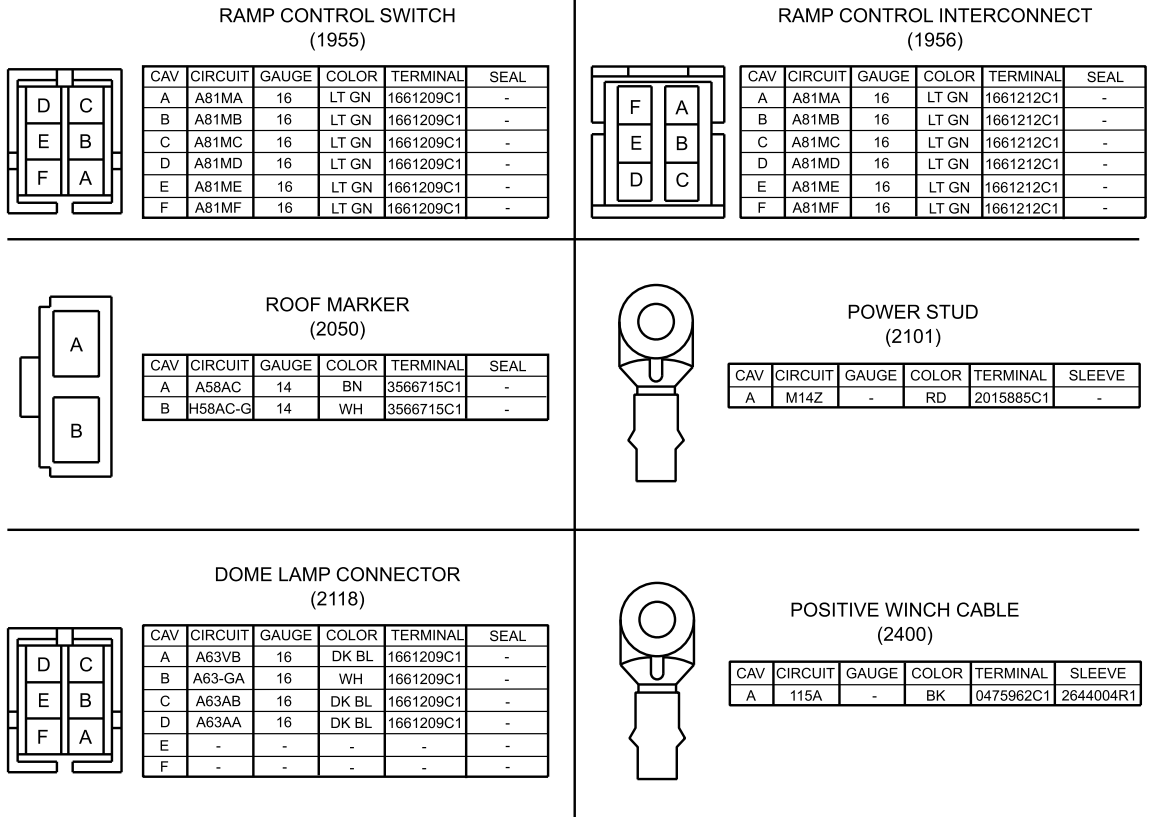

B235005776

Figure 19. Connector Composites (1955, 1956, 2050, 2101, 2118, 2400).

CONNECTOR COMPOSITES - (CONTINUED)

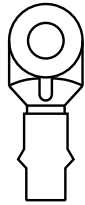

NEGATIVE WINCH CABLE
(2401)

CAV	CIRCUIT	GAUGE	COLOR	TERMINAL	SLEEVE
A	115G	-	BK	0475962C1	2644004R1

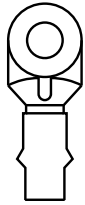

POSITIVE WINCH CABLE
(2500)

CAV	CIRCUIT	GAUGE	COLOR	TERMINAL	SLEEVE
A	115A	-	RD	-	-

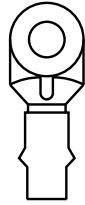

NEGATIVE WINCH CABLE
(2501)

CAV	CIRCUIT	GAUGE	COLOR	TERMINAL	SLEEVE
A	115A	-	BK	-	-

DRIVER DOOR CONNECTOR
(3000M)

CAV	CIRCUIT	GAUGE	COLOR	TERMINAL	SEAL
A	A78A	20	LT GN	3544254C1	-
B	A78KA	18	LT GN	1661261C1	-
C	A78C	20	LT GN	3544254C1	-
D	A78H	18	LT GN	3515517C1	-
E	-	-	-	-	-
F	-	-	-	-	-
G	-	-	-	-	-
H	A78-GD	20	WH	3544254C1	-

PASSENGER DOOR CONNECTOR
(3003M)

CAV	CIRCUIT	GAUGE	COLOR	TERMINAL	SEAL
A	A78D	20	LT GN	3544254C1	-
B	A78KB	18	LT GN	1661261C1	-
C	A78F	20	LT GN	3544254C1	-
D	A78J	18	LT GN	3515517C1	-
E	-	-	-	-	-
F	-	-	-	-	-
G	-	-	-	-	-
H	A78-GB	18	WH	1661261C1	-

B235005777

Figure 20. Connector Composites (2401, 2500, 2501, 3000M, 3003M).

CONNECTOR COMPOSITES - (CONTINUED)

MINI-FUSE BLOCKS
(4001)
(LOCATED IN POWER DISTRIBUTION CENTER)

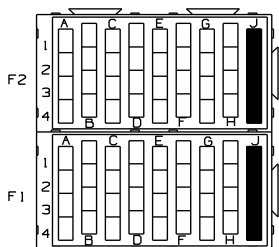

CONNECTOR - 3545599C91
BODY LOCK - 3599541C1

CAV	CIRCUIT	GAUGE	COLOR	TERMINAL
F1-A1	(J13S)	-	-	3536304C1
F1-B1	J71	18	OR	3515517C1
F1-C1	(J13S)	-	-	3536304C1
F1-D1	-	-	-	-
F1-E1	J13S	14	PK	3536304C1
F1-F1	J97UA	16	VT	3573312C1
F1-G1	(J13S)	-	-	3536304C1
F1-H1	J23FS	16	TN	3573312C1
F1-A2	(J13W)	-	-	3536304C1
F1-B2	J24C	16	GY	3515517C1
F1-C2	(J13W)	-	-	3536304C1
F1-D2	J87KA	16	GY	3573312C1
F1-E2	J13W	14	PK	3536304C1
F1-F2	J94AYA	16	GY	3573312C1
F1-G2	(J13W)	-	-	3536304C1
F1-H2	J92 #163	18	YL	3515517C1
F1-A3	(J13E)	-	-	3536301C1
F1-B3	-	-	-	-
F1-C3	(J13E)	-	-	3536301C1
F1-D3	J13X	16	PK	3573312C1
F1-E3	J13E	14	PK	3536301C1
F1-F3	J39A	16	GY	3573311C1
F1-G3	J39B	16	GY	3573311C1
F1-H3	J11-GG	18	WH	3515517C1
F1-J3	J70D	18	OR	-
F1-A4	(J13T)	-	-	3536301C1
F1-B4	-	-	-	-
F1-C4	(J13T)	-	-	3536301C1
F1-D4	-	-	-	-
F1-E4	J13T	14	PK	3536301C1
F1-F4	-	-	-	-
F1-G4	J70C	18	OR	3515517C1
F1-H4	-	-	-	-
F1-J4	J113G	18	YL	3515517C1

CAV	CIRCUIT	GAUGE	COLOR	TERMINAL
F2-A1	(J14VA)	-	-	3536303C1
F2-B1	J71C	18	OR	3515517C1
F2-C1	J14VA	10	RD	3536303C1
F2-D1	J70BK	14	OR	3573312C1
F2-E1	(J14VA)	-	-	3536303C1
F2-F1	J58BK	14	BN	3573312C1
F2-G1	(J14VA)	-	-	3536303C1
F2-H1	J14AA	16	RD	3515517C1
F2-A2	(J14VB)	-	-	3536303C1
F2-B2	J75	14	LTGN	3573312C1
F2-C2	J14VB	10	RD	3536303C1
F2-D2	J72	14	OR	3573312C1
F2-E2	(J14VB)	-	-	3536303C1
F2-F2	J57T	14	OR	3573312C1
F2-G2	(J14VB)	-	-	3536303C1
F2-H2	J56T	14	OR	3573312C1
F2-A3	J70SA	12	OR	3573311C1
F2-B3	J70B	14	RD	3573312C1
F2-C3	(J14M)	-	-	3536301C1
F2-D3	-	-	-	-
F2-E3	J14M	12	RD	3536301C1
F2-F3	-	-	-	-
F2-G3	(J14M)	-	-	3536301C1
F2-H3	J19	16	GY	3573312C1
F2-A4	J68E	14	BN	3573312C1
F2-B4	J68F	14	BN	3573312C1
F2-C4	(J14J)	-	-	3536301C1
F2-D4	-	-	-	-
F2-E4	J14J	12	RD	3536301C1
F2-F4	J94AY	12	GY	3573311C1
F2-G4	(J14J)	-	-	3536301C1
F2-H4	J70L	18	OR	3573312C1
F2-H4	J68L	18	BN	3573312C1

MINI-FUSE BLOCK (4001)

LOCATION	FUSE	PART NUMBER	DESCRIPTION	LOCATION	FUSE	PART NUMBER	DESCRIPTION
F1-A1&B1	10 AMP	3534209C1	BACK UP LAMPS	F2-A1&B1	10 AMP	3534209C1	BACK UP LIGHTS
F1-C1&D1	-	-	-	F2-C1&D1	10 AMP	3534209C1	B/O STOP LIGHT TRAILER
F1-E1&F1	5 AMP	3534208C1	ENGINE IGN	F2-E1&F1	10 AMP	3534209C1	B/O MARKER TRAILER
F1-G1&H1	10 AMP	3534209C1	ENGINE FAN WIRING	F2-G1&H1	10 AMP	3534209C1	24 VOLT ALT IGNITION
F1-A2&B2	5 AMP	3534208C1	EXHAUST BRAKE	F2-A2&B2	15 AMP	3534210C1	FUEL FIRED HEATER
F1-C2&D2	10 AMP	3534209C1	WASHER PUMP	F2-C2&D2	15 AMP	3534210C1	TRAILER ABS/AUX PWR
F1-E2&F2	5 AMP	3534208C1	AIR ABS	F2-E2&F2	15 AMP	3534210C1	TRAILER RIGHT TURN
F1-G2&H2	10 AMP	3534209C1	XMSN ECU	F2-G2&H2	15 AMP	3534210C1	TRAILER LEFT TURN
F1-A3&B3	-	-	-	F2-A3&B3	15 AMP	3534210C1	TRAILER STOP LIGHTS
F1-C3&D3	10 AMP	3534209C1	IGNITION BUS	F2-C3&D3	-	-	-
F1-E3&F3	20 AMP	3534211C1	AIR DRYER	F2-E3&F3	5 AMP	-	REMOTE PWR MDL
F1-G3&H3	-	-	-	F2-G3&H3	20 AMP	3534211C1	FUEL/WATER SEPARATOR
F1-A4&B4	-	-	-	F2-A4&B4	15 AMP	3534210C1	REAR MARKER & TAIL
F1-C4&D4	-	-	-	F2-C4&D4	-	-	-
F1-E4&F4	-	-	-	F2-E4&F4	30 AMP	3534213C1	AIR ABS
F1-G4&H4	-	-	-	F2-G4&H4	10 AMP	3534209C1	MRKR & TAIL/TRLR STOP

1 MICRO RELAY FOR TRAILER STOP LT INTRPT AT
F1 - G3 H3 J3
G4 J4

B235002819

Figure 21. Connector Composites (4001).

CONNECTOR COMPOSITES - (CONTINUED)

MICRO RELAY BLOCKS
(4002)
(LOCATED IN POWER DISTRIBUTION CENTER)

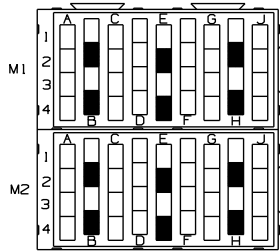

- CONNECTOR ASSY - 3545598C1
- BODY LOCK - 3536085C1 (2 REOD)
- BODY LOCK - 3599541C1 (8 REOD)
- MICRO RELAY - 3519350C1
- PLUG - 3555642C1

CAV	CIRCUIT	GAUGE	COLOR	TERMINAL
M1-A1	J11-GZ	18	WH	3515517C1
M1-B1	-	-	-	-
M1-C1	J13AA	16	PK	3573312C1
M1-C1	J13AB	18	PK	3573312C1
M1-A2	J14AA	16	RD	3573312C1
M1-C2	J13AC	18	PK	3515517C1
M1-D1	J71#165	18	OR	3515517C1
M1-E1	-	-	-	-
M1-F1	J71D	18	OR	3515517C1
M1-D2	J71C	18	OR	3515517C1
M1-F2	J71	18	OR	3515517C1
M1-G1	J11-GX	18	WH	3515517C1
M1-H1	-	-	-	-
M1-J1	J71B	18	OR	3515517C1
M1-G2	J71D	18	OR	3515517C1
M1-J2	J113E	18	YL	3515517C1
M1-A3	J24A	16	GY	3573312C1
M1-B3	-	-	-	-
M1-C3	J24B	16	GY	3573312C1
M1-A4	-	-	-	-
M1-C4	J24C	16	GY	3573312C1
M1-D3	J11-GY	18	WH	3515517C1
M1-E3	-	-	-	-
M1-F3	J85AB	16	GY	3573312C1
M1-D4	J85AA	16	GY	3573312C1
M1-F4	J113F	18	YL	3515517C1
M1-G3	J19-G	18	WH	3515517C1
M1-H3	-	-	-	-
M1-J3	J19	16	GY	3573312C1
M1-G4	J19A	16	GY	3573312C1
M1-J4	J13AS	18	PK	3515517C1

CAV	CIRCUIT	GAUGE	COLOR	TERMINAL
M2-A1	J11-GP	18	WH	3515517C1
M2-B1	J56L	16	OR	3573312C1
M2-B3	J56K	14	OR	3573311C1
M2-C1	J56JA	18	OR	3515517C1
M2-A2	J56B	16	OR	3573312C1
M2-C2	J113D	18	YL	3515517C1
M2-D1	J11-GC	18	WH	3515517C1
M2-E1	J57L	18	OR	3515517C1
M2-F1	J70JB	16	OR	3573312C1
M2-D2	J57B	16	OR	3573312C1
M2-F2	J113J	18	YL	3515517C1
M2-G1	J11-GW	18	WH	3515517C1
M2-H1	J70BH	14	OR	3573311C1
M2-H1	J70BJ	16	OR	3573311C1
M2-J1	J113CC	14	YL	3573312C1
M2-G2	J70BE	18	OR	3515517C1
M2-J2	J113CA	16	YL	3573312C1
M2-A3	J11-GR	18	WH	3515517C1
M2-B3	J56L	16	OR	3573311C1
M2-C3	J56T	14	OR	3573312C1
M2-A4	J56C	14	OR	3573312C1
M2-C4	J56J	16	OR	3573312C1
M2-C4	J56JA	18	OR	3573312C1
M2-D3	J11-GF	18	WH	3515517C1
M2-E3	J57K	14	OR	3573311C1
M2-E3	J57L	18	OR	3573311C1
M2-F3	J57T	14	OR	3573312C1
M2-D4	J57C	14	GY	3573312C1
M2-F4	J70JC	16	OR	3573312C1
M2-G3	J11-GV	18	WH	3515517C1
M2-H3	J70BJ	16	OR	3573312C1
M2-J3	J70BK	14	OR	3573312C1
M2-G4	J70BF	14	OR	3573312C1
M2-J4	J113CD	16	YL	3573312C1

LOCATION	DESCRIPTION
M1-A1 TO M1-C2	24 VOLT IGN
M1-D1 TO M1-F2	BACKUP LAMPS
M1-G1 TO M1-J2	BACKUP LIGHT INTRPT
M1-A3 TO M1-C4	EXHAUST BRAKE
M1-D3 TO M1-F4	ELECTRIC HORN
M1-G3 TO M1-J4	FUEL HEATER
M2-A1 TO M2-C2	LEFT STOP/TURN
M2-D1 TO M2-F2	RIGHT STOP/TURN
M2-G1 TO M2-J2	B/O STOP TRUCK
M2-A3 TO M2-C4	LEFT TURN TRAILER
M2-D3 TO M2-F4	RIGHT TURN TRAILER
M2-G3 TO M2-J4	B/O STOP LT TRAILER

B235002820

Figure 22. Connector Composites (4002).

CONNECTOR COMPOSITES - (CONTINUED)

ISO & POWER RELAYS (4003)
(LOCATED IN POWER DISTRIBUTION CENTER)

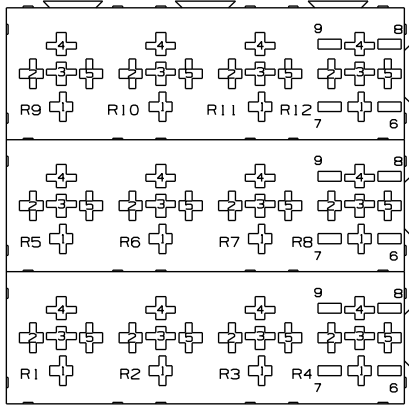

LOCATION	DESCRIPTION
R1	WIPER POWER
R2	WIPER HIGH/LOW
R3	B/O MARKER TRAILER
R4	B/O MARKER TRUCK
R5	TRAILER ABS CENTER PIN
R6	TRAILER MARKER TAIL LIGHT
R7	TRAILER STOP
R8	AIR COND
R9	IGN
R10	TRUCK MARKER TAIL
R11	CEC POWER MODULE
R12	STARTER

CONNECTOR ASSY - 3545600C9I
BODY LOCK - 3536093C1
ISO RELAY - 2012557C1

CAV	CIRCUIT	GAUGE	COLOR	TERMINAL
R1-1	J82HLP	16	GY	1661226C1
R1-2	J82RP	18	GY	1661224C1
R1-3	J82P	16	GY	1661226C1
R1-4	J82HL	16	GY	1661226C1
R1-5	J82FB	18	GY	1661224C1
R2-1	J82HLP	16	GY	1661226C1
R2-2	J82RH	18	GY	1661224C1
R2-3	J82L	16	GY	1661226C1
R2-4	J82H	16	GY	1661226C1
R2-5	J82FA	18	GY	1661224C1
R3-1	J58BF	14	BN	1661226C1
R3-2	J11-GN	18	WH	1661224C1
R3-3	J58BJ	18	OR	1661224C1
R3-4	J58BK	14	TN	1661226C1
R3-5	J113BD	16	BN	1661226C1
R4-1	J58BE	16	BN	1661226C1
R4-1	J68BA	18	BN	1661224C1
R4-2	J11-GK	18	WH	1661224C1
R4-3	J58BH	14	BN	1661227C1
R4-3	J58BJ	18	OR	1661227C1
R4-4	J113BB	14	TN	1661226C1
R4-5	J113BC	16	TN	1661226C1
R5-1	J72A	10	OR	1661227C1
R5-2	J72B	18	OR	1661224C1
R5-3	J72C	14	OR	1661226C1
R5-4	J72	14	OR	1661226C1
R5-5	J11-GT	18	WH	1661224C1
R6-1	J68E	14	BN	1661226C1
R6-2	J68B	18	OR	1661224C1
R6-3	J68H	14	BN	1661226C1
R6-3	J68J	14	TN	1661226C1
R6-4	J14VD	12	RD	1661227C1
R6-5	J68L	18	BN	1661224C1

CAV	CIRCUIT	GAUGE	COLOR	TERMINAL
R7-1	J70SA	12	OR	1661227C1
R7-2	J70D	18	OR	1661224C1
R7-3	J70A	14	OR	1661226C1
R7-4	J14VC	12	RD	1661227C1
R7-5	J70L	18	OR	1661224C1
R8-1	J77A	18	LT GN	1661224C1
R8-2	J77	16	LT GN	1661226C1
R8-3	-	-	-	-
R8-4	J9B	18	GY	1661224C1
R8-5	J11-GU	18	WH	1661224C1
R9-1	J13CW	10	PK	1661227C1
R9-2	J11-GD	18	WH	1661224C1
R9-3	J11-GE	12	WH	1661227C1
R9-4	J14D	12	RD	1661227C1
R9-5	J13C	16	PK	1661226C1
R10-1	J58AA	14	TN	1661226C1
R10-2	J113H	18	YL	1661224C1
R10-3	J68J	14	TN	1661226C1
R10-4	J58A	14	TN	1661226C1
R10-5	J11-GS	18	WH	1661224C1
R11-1	J97AA	12	VT	1661228C1
R11-1	J97AAA	14	VT	1661228C1
R11-2	J97T	18	VT	1661224C1
R11-3	-	-	-	-
R11-4	J97W	10	VT	1661227C1
R11-5	J97AAA	14	VT	1661226C1
R12-1	J17D	10	PK	1661227C1
R12-2	J17S	18	PK	1661224C1
R12-3	-	-	-	-
R12-4	J17E	10	PK	1661227C1
R12-5	J17	16	PK	1661226C1

B235002821

Figure 23. Connector Composites (4003).

CONNECTOR COMPOSITES - (CONTINUED)

ELECTRICAL SYSTEM CONTROLLER (ESC 4004)

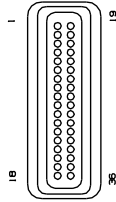

- CONNECTOR - 3533832C1
- RETAINER - 3533833C1
- STRAIN REL - 3533834C1
- SEAL - 3533835C1
- CPA - 3533836C1
- PLUG - 3518314C1

CAV	CIRCUIT	GAUGE	COLOR	TERMINAL
3	J77A	18	LTGN	3517243C1
5	J36A	18	TN	3517243C1
11	J19C	18	GY	3517243C1
12	J87CA	18	GY	3517243C1
17	J68B	18	OR	3517243C1
20	J82RH	18	GY	3517243C1
21	J70C	18	OR	3517243C1
22	J59C	18	GY	3517243C1
24	J59B	18	GY	3517243C1
26	J9A	18	GY	3517243C1
29	J82RP	18	GY	3517243C1
30	J59D	18	GY	3517243C1
31	J59A	18	GY	3517243C1

NOTE:
CAVITIES NOT LISTED HAVE PLUGS

FIREWALL GROUND STUD (4005)

TERMINAL - 0581156C1

CIRCUIT	GAUGE	COLOR
K11-GL	4	WH

GND 2 (4006)

CIRCUIT	GAUGE	COLOR	TERMINAL	SLEEVE
J11-GL	18	WH	3549254C1	2644005R1
J11-GB	16	WH	3549254C1	2644005R1
J42-G	18	WH	3549254C1	2644005R1

GND 3 (4006A)

TERMINAL - 3581768C1
SLEEVE - 2644005R1

CIRCUIT	GAUGE	COLOR
J11-GJ	12	WH

ELECTRICAL SYSTEM CONTROLLER BROWN (4007)

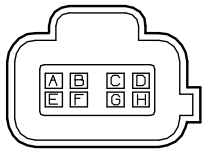

- CONNECTOR - 3548934C1
- BODY LOCK - 3548943C1
- PLUG - 3535938C1

CAV	CIRCUIT	GAUGE	COLOR	TERMINAL	SEAL
A	PLUG	-	-	-	-
B	J57A	16	OR	3535930C1	3535936C1
C	J56A	16	OR	3535930C1	3535936C1
D	J53A	14	YL	3535931C1	3548945C1
E	J85AA	16	GY	3535930C1	3535937C1
F	PLUG	-	-	-	-
G	J52A	14	YL	3535931C1	3548945C1
H	J58	14	BN	3535931C1	3548945C1

ELECTRICAL SYSTEM CONTROLLER BLUE (4008)

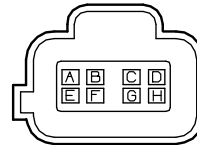

- CONNECTOR - 3548933C1
- BODY LOCK - 3548943C1
- PLUG - 3535938C1

CAV	CIRCUIT	GAUGE	COLOR	TERMINAL	SEAL
A	J59E	14	GY	3535931C1	3548945C1
B	J70	16	OR	3535930C1	3535937C1
C	J56	16	OR	3535930C1	3535937C1
D	PLUG	-	-	-	-
E	PLUG	-	-	-	-
F	J82F	16	GY	3535930C1	3535937C1
G	PLUG	-	-	-	-
H	PLUG	-	-	-	-

B235002822

Figure 24. Connector Composites (4004, 4005, 4006, 4006A, 4007, 4008).

CONNECTOR COMPOSITES - (CONTINUED)

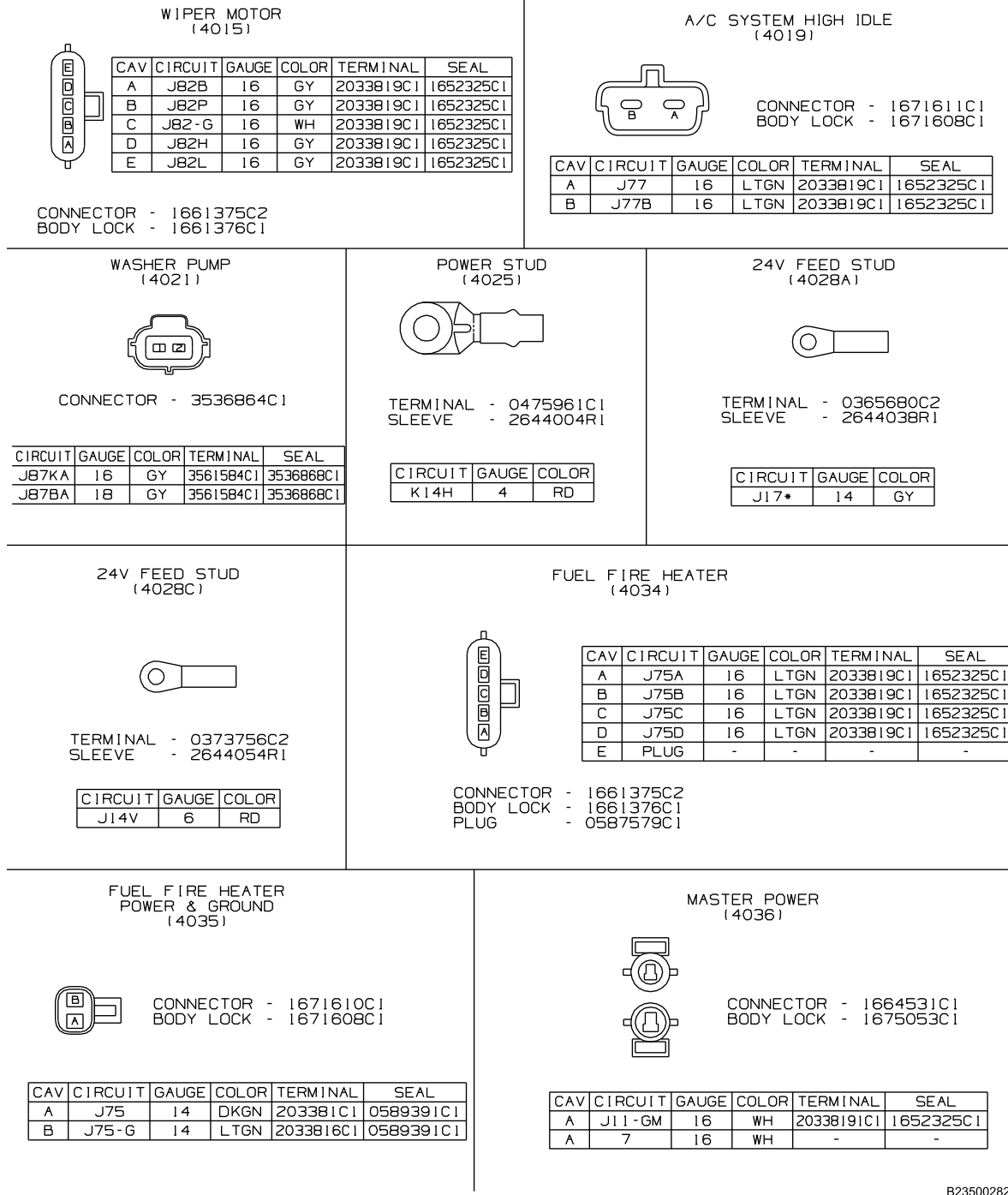

B235002823

Figure 25. Connector Composites (4015, 4019, 4021, 4025, 4028A, 4028C, 4034, 4035, 4036).

CONNECTOR COMPOSITES - (CONTINUED)

FUEL HEATER
(4042)

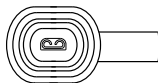

CONNECTOR - 1664024C91

CAV	CIRCUIT	GAUGE	COLOR	TERMINAL
A	M19A	16	GY	ASSY

WATER PROBE
(4043)



CONNECTOR - 089000-CA

CAV	CIRCUIT	GAUGE	COLOR	TERMINAL	SEAL
A	M19B	16	GY	0385565C1	089000-CA

DASH CONNECTOR
(4100F)

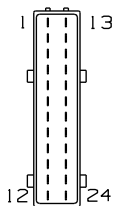

CONNECTOR - 3558022C1
LOCK - 3558056C1
SEAL - 3559047C1
PLUG - 3532129C1

NOTE:
MATES WITH CONNECTOR (4103)

CAV	CIRCUIT	GAUGE	COLOR	TERMINAL	SEAL
1	PLUG	-	-	-	-
2	K99S	18	VT	3559036C1	3509903C1
3	K97K	18	VT	3559036C1	3509903C1
4	K97C	18	VT	3559036C1	3509903C1
5	K99T	18	VT	3559036C1	3509903C1
6	K97R	18	VT	3559036C1	3509903C1
7	L5B (+)	18	YL	3559036C1	3532128C1
8	L5B (-)	18	GN	3559036C1	3532128C1
9	PLUG	-	-	-	-
10	K3A (+)	18	DKBL	3559036C1	3509903C1
11	K3A (-)	18	GY	3559036C1	3509903C1
12	K21B	18	TN	3559036C1	3509903C1
13	PLUG	-	-	-	-
14	K23A	16	TN	3559037C1	3509903C1
15	K24B	16	GY	3559037C1	3509903C1
16	K24A	18	GY	3559036C1	3509903C1
17	K17M	18	WH	3559036C1	3509903C1
18	K97J	16	VT	3559037C1	3509903C1
19	K97M	16	VT	3559037C1	3509903C1
20	K77A	16	LTGN	3559037C1	3509903C1
21	PLUG	-	-	-	-
22	PLUG	-	-	-	-
23	PLUG	-	-	-	-
24	K13AA	16	RD	3559037C1	3509903C1

DASH CONNECTOR
STARTER/CEC POWER
(4101M)



CONNECTOR - 1667733C1
BODY LOCK - 1667734C1

NOTE:
MATES WITH CONNECTOR (4105)

CAV	CIRCUIT	GAUGE	COLOR	TERMINAL	SEAL
A	K97W	10	VT	1667737C1	1667735C1
B	K97AA	10	VT	1667737C1	1667735C1
C	K17C	10	PK	1667737C1	1667735C1

B235002824

Figure 26. Connector Composites (4042, 4043, 4100F, 4101M).

CONNECTOR COMPOSITES - (CONTINUED)

ENGINE CONNECTOR
(4103)

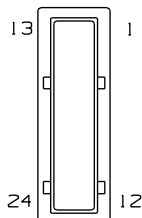

CONNECTOR - 3558026C1
LOCK - 3558056C1
PLUG - 3532129C1

NOTE:
MATES WITH CONNECTOR (4100F)

CAV	CIRCUIT	GAUGE	COLOR	TERMINAL	SEAL
1	PLUG	-	-	-	-
2	J99U	18	VT	3509874C1	3509903C1
3	J97Q	18	VT	3509874C1	3509903C1
4	J97P	18	VT	3509874C1	3509903C1
5	J99V	18	VT	3509874C1	3509903C1
6	J99Y	18	VT	3509874C1	3509903C1
7	J5B (+)	18	YL	3509874C1	3509903C1
8	J5B (-)	18	GN	3509874C1	3509903C1
9	PLUG	-	-	-	-
10	J3A (+)	18	DK BL	3509874C1	3509903C1
11	J3A (-)	18	GY	3509874C1	3509903C1
12	J21F	18	TN	3509874C1	3509903C1
13	PLUG	-	-	-	-
14	J23FS	18	TN	3509874C1	3509903C1
15	J24B	18	GY	3509874C1	3509903C1
16	J24A	18	GY	3509874C1	3509903C1
17	J17S	18	PK	3509874C1	3509903C1
18	J97T	18	VT	3509874C1	3509903C1
19	J97UA	18	VT	3509874C1	3509903C1
20	J77B	16	LT GN	3559035C1	3509903C1
21	PLUG	-	-	-	-
22	PLUG	-	-	-	-
23	PLUG	-	-	-	-
24	J13AA	16	PK	3509874C1	3509903C1

CEC POWER/
STARTER SOLENOID
(4105)

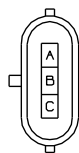

CONNECTOR - 1667732C1
BODY LOCK - 1667734C1

NOTE:
MATES WITH CONNECTOR (4101M)

CAV	CIRCUIT	GAUGE	COLOR	TERMINAL	SEAL
A	J97W	10	VT	2025425C1	1667735C1
B	J97AA	12	VT	2025424C1	1671603C1
C	J17E	10	PK	2025425C1	1667735C1

FAN SOLENOID
(4111M)



CONNECTOR - 1671610C1
BODY LOCK - 1671608C1

CAV	CIRCUIT	GAUGE	COLOR	TERMINAL	SEAL
A	K23A	16	TN	2033819C1	1652325C1
B	K97B	18	VT	2033819C1	1652325C1

B235002825

Figure 27. Connector Composites (4103, 4105, 4111M).

CONNECTOR COMPOSITES - (CONTINUED)

DASH HARNESS CONNECTOR
(4300)

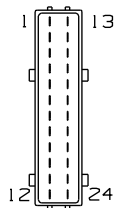

- CONNECTOR - 3558022C1
- LOCK - 3558056C1
- PLUG - 3532129C1

NOTE:
MATES WITH CONNECTOR (4301)

CAV	CIRCUIT	GAUGE	COLOR	TERMINAL	SEAL
1	M94	18	GY	3559036C1	3509903C1
2	M94A	18	GY	3559036C1	3509903C1
3	M94B	18	GY	3559036C1	3509903C1
4	M52B	14	YL	3559037C1	3575783C1
5	M53	14	YL	3559037C1	3575783C1
6	M94C	18	GY	3559036C1	3509903C1
7	M94D	18	GY	3559036C1	3509903C1
8	PLUG	-	-	-	-
9	M56B	16	OR	3559037C1	3509903C1
10	M85M	16	GY	3559037C1	3509903C1
11	M57B	16	OR	3559037C1	3509903C1
12	M56B	16	BN	3559037C1	3509903C1
13	M11-G	12	WH	3559037C1	3575834C1
14	M94E	18	GY	3559036C1	3509903C1
15	M94F	18	GY	3559036C1	3509903C1
16	M94H	18	GY	3559036C1	3509903C1
17	M94J	18	GY	3559036C1	3509903C1
18	M94K	18	GY	3559036C1	3509903C1
19	M21C	18	TN	3559036C1	3509903C1
20	M52	16	YL	3559037C1	3509903C1
21	M53C	16	YL	3559037C1	3509903C1
22	M21D	18	TN	3559036C1	3509903C1
23	M54	16	BN	3559037C1	3509903C1
24	PLUG	-	-	-	-

FWD CHASSIS CONNECTOR
(4301)

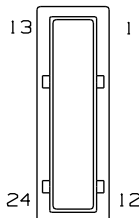

- CONNECTOR - 3558026C1
- BODY LOCK - 3558056C1
- SEAL - 3559047C1
- PLUG - 3532129C1

NOTE:
MATES WITH CONNECTOR (4300)

CAV	CIRCUIT	GAUGE	COLOR	TERMINAL	SEAL
1	J94AP	18	GY	3509874C1	3509903C1
2	J94AR	18	GY	3509874C1	3509903C1
3	J94AS	18	GY	3509874C1	3509903C1
4	J52A	14	YL	3559035C1	3575783C1
5	J52A	14	YL	3559035C1	3575783C1
6	J94AM	18	GY	3509874C1	3509903C1
7	J94AN	18	GY	3509874C1	3509903C1
8	PLUG	-	-	-	-
9	J56A	16	OR	3559035C1	3509903C1
10	J85AB	16	GY	3559035C1	3509903C1
11	J57A	16	OR	3559035C1	3509903C1
12	J58AB	14	BN	3559035C1	3575783C1
13	J11-G	12	WH	3559035C1	3575783C1
14	J94AT	16	GY	3559035C1	3509903C1
15	J94AU	16	GY	3559035C1	3509903C1
16	J94AV	18	GY	3509874C1	3509903C1
17	J94AW	18	GY	3509874C1	3509903C1
18	J94AX	18	GY	3509874C1	3509903C1
19	J21E	18	TN	3509874C1	3509903C1
20	J114	16	YL	3559035C1	3509903C1
21	J113A	16	YL	3559035C1	3509903C1
22	J21F	18	TN	3509874C1	3509903C1
23	J58BE	16	BN	3559035C1	3509903C1
24	PLUG	-	-	-	-

B235002826

Figure 28. Connector Composites (4300, 4301).

CONNECTOR COMPOSITES - (CONTINUED)

FWD CHASSIS CONN
(4305M)



CONNECTOR - 3571887C1
BODY LOCK - 2039342C1
PLUG - 0587579C1

NOTE:
CAVITIES NOT SHOWN HAVE PLUGS.

CAV	CIRCUIT	GAUGE	COLOR	TERMINAL	SEAL
D	J19C	18	GY	2039343C1	3517771C1
E	J19A	16	GY	2039343C1	1652325C1

AUX DASH CONN
(4305F)

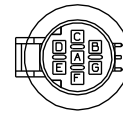

CONNECTOR - 3571886C1
BODY LOCK - 2039342C1
PLUG - 0587579C1

NOTE:
CAVITIES NOT SHOWN HAVE PLUGS

CAV	CIRCUIT	GAUGE	COLOR	TERMINAL	SEAL
D	M19B	16	GY	2033911C1	1652325C1
E	M19A	16	GY	2033911C1	1652325C1

← MATES WITH →

DASH/XMSN CONN
(4705F1)

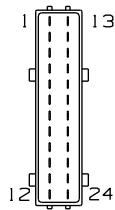

CONNECTOR - 3558022C1
LOCK - 3558056C1
SEAL - 3559047C1
PLUG - 3532129C1

NOTE:
CAVITIES NOT SHOWN HAVE PLUGS.

CAV	CIRCUIT	GAUGE	COLOR	TERMINAL	SEAL
1	J92#134	18	YL	3559036C1	3532128C1
12	J92#163	18	YL	3559036C1	3532128C1
13	J71#165	18	OR	3559036C1	3532128C1

DASH/XMSN CONN
(4705F2)

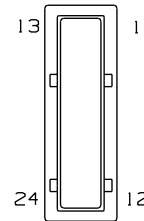

CONNECTOR - 3558026C1
BODY LOCK - 3558056C1
PLUG - 3532129C1

NOTE:
CAVITIES NOT SHOWN HAVE PLUGS

CAV	CIRCUIT	GAUGE	COLOR	TERMINAL	SEAL
1	L92#134	18	YL	3509874C1	3532128C1
12	L92#163	18	YL	3509874C1	3532128C1
13	L71#165	18	TN	3509874C1	3532128C1

← MATES WITH →

B235002827

Figure 29. Connector Composites (4305M, 4305F, 4705F1, 4705F2,).

CONNECTOR COMPOSITES - (CONTINUED)

ELECTRONIC SPLICE
(4811)

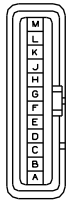

CONNECTOR - 3543730C1
 BODY LOCK - 3543732C1
 PLUG - 3535425C1
 BUS BAR - 3543735C1

CAV	CIR	GAUGE	COLOR	TERMINAL	SEAL
A	J11-GL	18	WH	3535303C1	3535424C1
B	J11-GK	18	WH	3535303C1	3535424C1
C	J11-GN	18	WH	3535303C1	3535424C1
D	J11-GP	18	WH	3535303C1	3535424C1
E	J11-GR	18	WH	3535303C1	3535424C1
F	J11-GS	18	WH	3535303C1	3535424C1
G	J11-GT	18	WH	3535303C1	3535424C1
H	J11-GU	18	WH	3535303C1	3535424C1
J	J11-GV	18	WH	3535303C1	3535424C1
K	J11-GW	18	WH	3535303C1	3535424C1
L	J11-GG	18	WH	3535303C1	3535424C1
M	PLUG	-	-	-	-

ELECTRONIC GROUND SPLICE
(4830)



CONNECTOR - 3543730C1
 BODY LOCK - 3543732C1
 PLUG - 3535425C1
 BUS BAR - 3543735C1

NOTE:
 CAVITIES NOT SHOWN HAVE PLUGS

CAV	CIRCUIT	GAUGE	COLOR	TERMINAL	SEAL
A	J9G	18	GY	3535303C1	3535424C1
B	J9A	18	GY	3535303C1	3535424C1
C	J9B	18	GY	3535303C1	3535424C1

IGNITION SPLICE
(4840)

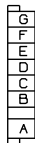

CONNECTOR - 2006789C1
 BODY LOCK - 2006792C1
 BUS BAR - 2006791C1
 COVER - 2006790C1

CAV	CIRCUIT	GAUGE	COLOR	TERMINAL
A	J13X	16	PK	1661209C1
B	-	-	-	-
C	J13AS	18	PK	1661208C1
D	-	-	-	-
E	J13AC	18	PK	1661208C1
F	-	-	-	-
G	J72B	18	OR	1661208C1

TRANSFER CASE
 CONNECTION
(4900)

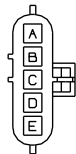

CONNECTOR - 1677851C1
 BODY LOCK - 1677914C1
 PLUG - 0587579C1

NOTE:
 CAVITIES NOT SHOWN HAVE PLUGS

CAV	CIRCUIT	GAUGE	COLOR	TERMINAL	SEAL
A	N42	18	GY	2033911C1	1652325C1
B	N42-G	18	WH	2033911C1	1652325C1

TRANSFER CASE
 CONNECTION
(4910)

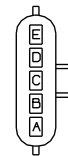

CONNECTOR - 1661375C2
 BODY LOCK - 1661376C1
 PLUG - 0587579C1

NOTE:
 CAVITIES NOT SHOWN HAVE PLUGS.

CAV	CIRCUIT	GAUGE	COLOR	TERMINAL	SEAL
A	J42	18	GY	2033819C1	1652325C1
B	J42-G	18	WH	2033819C1	1652325C1

B235002828

Figure 30. Connector Composites (4811, 4830, 4840, 4900, 4910).

CONNECTOR COMPOSITES - (CONTINUED)

ABS CONN X1
(4953)

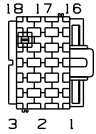

CONNECTOR - 3596926C1
BODY LOCK - 3562309C1

CAV	CIRCUIT	GAUGE	COLOR	TERMINAL
1	A94-GA	12	GY	3597157C1
2	-	-	-	-
3	A94AYA	16	GY	3598073C1
4	-	-	-	-
5	-	-	-	-
6	-	-	-	-
7	A5AJ(-)	18	GN	3598072C1
8	A5AJ(+)	18	YL	3598072C1
9	-	-	-	-
10	A94AK	16	GY	3598073C1
11	A94AL	16	GY	3598073C1
12	-	-	-	-
13	A3D(-)	18	GY	3598072C1
14	A3D(+)	18	DK BL	3598072C1
15	-	-	-	-
16	A94AY	12	GY	3597157C1
17	-	-	-	-
18	A94H	18	GY	3548969C1

ABS CONN X2
(4954)

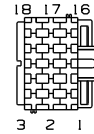

CONNECTOR - 3596929C1

CAV	CIRCUIT	GAUGE	COLOR	TERMINAL
1	A94AS	18	GY	3598072C1
2	A94AP	18	GY	3598072C1
3	A94AR	18	GY	3598072C1
4	A94AX	18	GY	3598072C1
5	A94AM	18	GY	3598072C1
6	A94AW	18	GY	3598072C1
7	A94AV	18	GY	3598072C1
8	A94AN	18	GY	3598072C1
9	A94AH	18	GY	3598072C1
10	A94AJ	18	GY	3598072C1
11	A94AT	16	GY	3598073C1
12	A94AD	18	GY	3598072C1
13	A94AF	18	GY	3598072C1
14	A94AU	16	GY	3598073C1
15	A94AA	16	GY	3598073C1
16	A94AE	18	GY	3598072C1
17	A94AC	18	GY	3598072C1
18	A94AB	16	GY	3598073C1

CEC
ENG CNTRL
(6007)

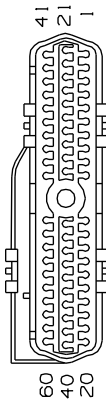

CONNECTOR - 3541979C1
BODY LOCK - 2041418C1
PLUG - 2041421C2
COVER - 3541958C91

NOTE:
CAVITIES NOT SHOWN HAVE PLUGS

CAV	CIRCUIT	GAUGE	COLOR	TERMINAL
1	K97V	14	VT	2041420C1
2	K97P	14	VT	2041420C1
3	K97C	18	VT	2041419C1
8	K99T	18	VT	2041419C1
10	K34A	18	TN	2041419C1
11	K97D	18	VT	2041419C1
12	K97E	12	VT	2041420C1
16	K3A(+)	18	DK BL	2041419C1
17	K3A(-)	18	GY	2041419C1
19	L5A(+)	18	YL	2041419C1
20	L5A(-)	18	GN	2041419C1
21	K97F	14	VT	2041420C1
22	K97Z	14	VT	2041420C1
23	K97N	14	VT	2041420C1
24	K97M	16	VT	2041420C1
25	K97J	16	VT	2041420C1
26	L92#141	18	TN	2041419C1
27	K99S	18	VT	2041419C1
29	K97K	18	VT	2041419C1
39	K47	18	GY	2041419C1
40	K47A	18	GY	2041420C1
41	K97L	14	VT	2041420C1
42	K97Y	14	VT	2041420C1
46	K17M	18	WH	2041419C1
47	K24A	18	GY	2041419C1

B235002851

Figure 31. Connector Composites (4953, 4954, 6007).

CONNECTOR COMPOSITES - (CONTINUED)

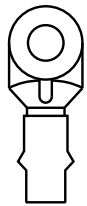

ALTERNATOR POWER
(6102)

CAV	CIRCUIT	GAUGE	COLOR	TERMINAL	SLEEVE
A	K2B	2	RD	0475962C1	-

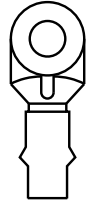

ALTERNATOR POWER
(6103)

CAV	CIRCUIT	GAUGE	COLOR	TERMINAL	SLEEVE
A	K2A	2	RD	0475962C1	-

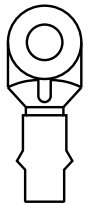

ALTERNATOR GROUND
(6104)

CAV	CIRCUIT	GAUGE	COLOR	TERMINAL	SLEEVE
A	K2A-G	2	RD	0475962C1	-

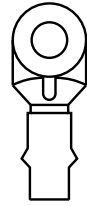

ALTERNATOR GROUND
(6105)

CAV	CIRCUIT	GAUGE	COLOR	TERMINAL	SLEEVE
A	K2B-G	2	RD	0475962C1	-

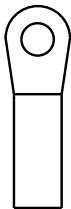

ALTERNATOR IGNITION
(6106)

CAV	CIRCUIT	GAUGE	COLOR	TERMINAL	SEAL
A	K13AA	16	RD	-	-



12V DISCONNECT SWITCH
(6108)

CAV	CIRCUIT	GAUGE	COLOR	TERMINAL	SEAL
A	M14ZB-FL	-	RD	2020632C1	-

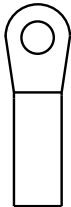

12V DISCONNECT SWITCH
(6109)

CAV	CIRCUIT	GAUGE	COLOR	TERMINAL	SEAL
A	M14ZA-FL	-	RD	2020632C1	-



ENGINE BLOCK GROUND
(6302)

CAV	CIRCUIT	GAUGE	COLOR	TERMINAL	SEAL
A	K10-GB	14	WH	-	-

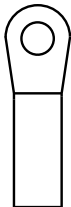

STARTER "S" TERMINAL
(6306)

CAV	CIRCUIT	GAUGE	COLOR	TERMINAL	SEAL
A	K17C	10	PK	0365682C2	-

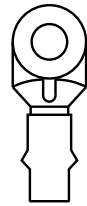

ENGINE BLOCK GROUND
(6307)

CAV	CIRCUIT	GAUGE	COLOR	TERMINAL	SEAL
A	K2A-G	2	WH	-	-

B235005778

Figure 32. Connector Composites (6102, 6103, 6104, 6105, 6106, 6108, 6109, 6302, 6306, 6307).

CONNECTOR COMPOSITES - (CONTINUED)

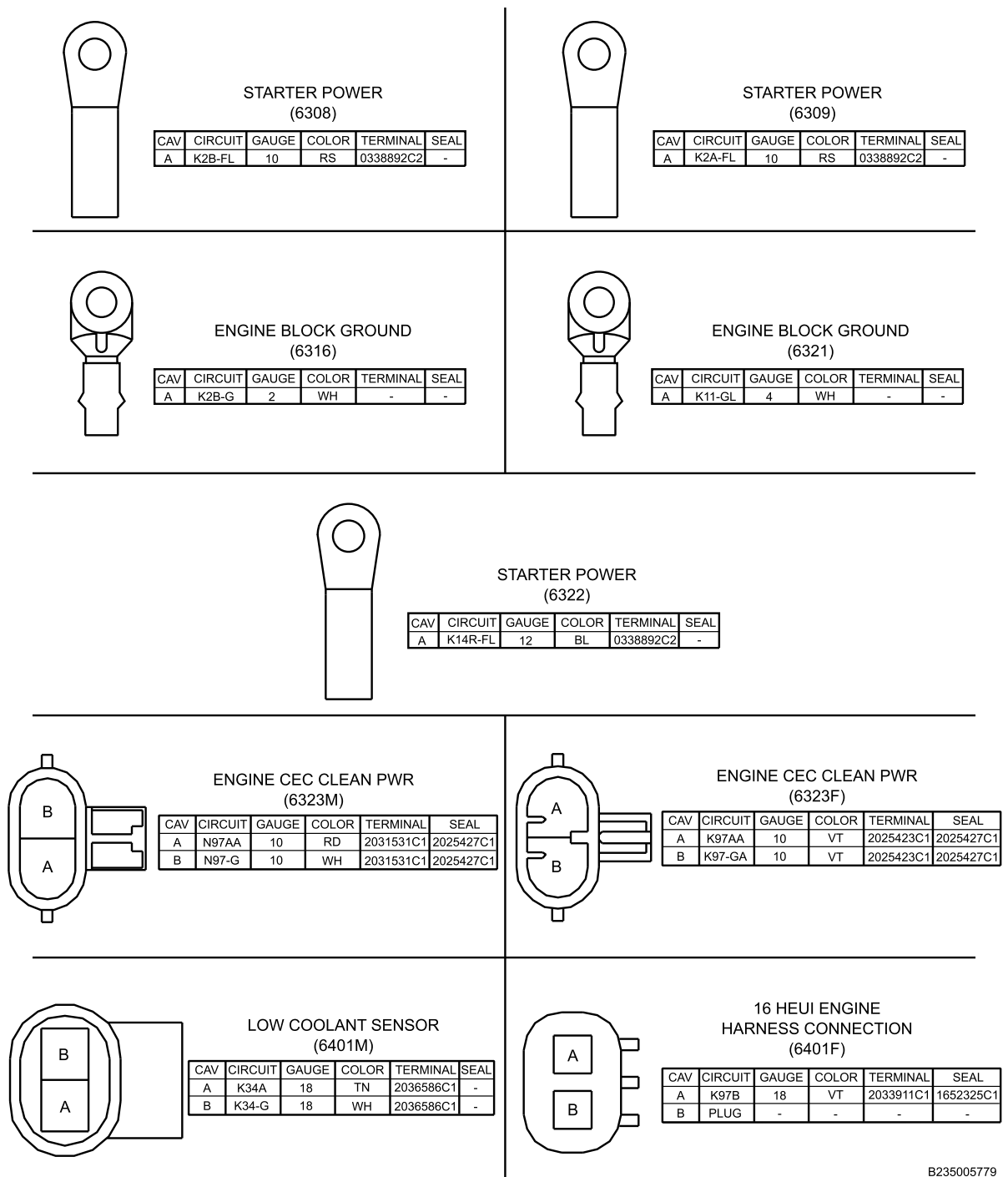

B235005779

Figure 33. Connector Composites (6308, 6309, 6316, 6321, 6322, 6323M, 6323F, 6401M, 6401F).

CONNECTOR COMPOSITES - (CONTINUED)

EXHAUST BRAKE SOLENOID
(6502)



CONNECTOR - 0188395R1

CAV	CIRCUIT	GAUGE	COLOR	TERMINAL
A	K24B	16	GY	0188396C1

EXHAUST BRAKE
SOLENOID GROUND
(6503)



TERMINAL - 0365679C2
SLEEVE - 2644038R1

CIRCUIT	GAUGE	COLOR
K24-G	18	WH

ETHER START THERMOSTAT
(6550M)



CONNECTOR - 1671610C1
BODY LOCK - 1671608C1

CAV	CIRCUIT	GAUGE	COLOR	TERMINAL	SEAL
A	K21B	18	TN	2033819C1	1652325C1
B	K21-G	18	WH	2033819C1	1652325C1

INTAKE AIR TEMPERATURE
(IAT) SENSOR
(6703)



CONNECTOR - 1689462C1
BODY LOCK - 1689463C1

CAV	CIRCUIT	GAUGE	COLOR	TERMINAL
A	K97E	16	VT	1689464C1
B	K97S	16	VT	1689464C1

GROUND SPLICE
(6704)

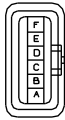

CONNECTOR - 3543729C1
BODY LOCK - 3543731C1
BUS BAR - 3543734C1

CAV	CIRCUIT	GAUGE	COLOR	TERMINAL	SEAL
1	K24-G	18	WH	353530C1	353542C1
2	K77-G	18	WH	353530C1	353542C1
3	K10-G	18	WH	353530C1	353542C1
4	K10-GA	18	WH	353530C1	353542C1
5	K34-G	18	WH	353530C1	353542C1
6	K21-G	18	WH	353530C1	353542C1

TRANSMISSION CONTROL
MODULE CLEAN POWER
(7104F)



CONNECTOR - 1671611C1
BODY LOCK - 1671608C1

CAV	CIRCUIT	GAUGE	COLOR	TERMINAL	SEAL
A	N92A	10	PK	167847C1	0589390C1
B	N92-G	10	GY	167847C1	0589390C1

TRANSMISSION CONTROL
MODULE CLEAN POWER
(7104M)



CONNECTOR - 1671610C1
BODY LOCK - 1671608C1

NOTE:
THESE CIRCUITS ARE IN A SEPERATE CABLE
ASSY, NOT THE CENTER CHASSIS HARNESS.

CAV	CIRCUIT	GAUGE	COLOR	TERMINAL	SEAL
A	N92A	14	RD	2033816C1	0589391C1
B	N92-G	14	WH	2033816C1	0589391C1

B235002853

← MATES WITH →

Figure 34. Connector Composites (6502, 6503, 6550M, 6703, 6704, 7104F, 7104M).

CONNECTOR COMPOSITES - (CONTINUED)

TRANSMISSION CONTROL MODULE (7150F)

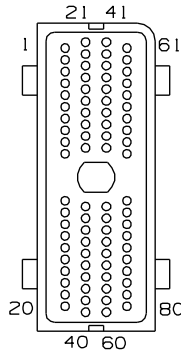

CONNECTOR - 3605713C1
BODY LOCK - 3606525C1

CAV	CIRCUIT	GAUGE	COLOR	TERMINAL
1	L92#101	18	DKBL	3606047C1
2	-	-	-	-
3	L92#103	18	YL	3606047C1
4	-	-	-	-
5	L92#105	18	TN	3606047C1
6	-	-	-	-
7	-	-	-	-
8	L5A108	18	GN	3606047C1
9	L92#109	18	GY	3606047C1
10	L92#110	18	GY	3606047C1
11	L92#111	18	OR	3606047C1
12	L92#112	18	PK	3606047C1
13	-	-	-	-
14	-	-	-	-
15	-	-	-	-
16	L92#116	18	DKBL	3606047C1
17	L92#117	18	DKBL	3606047C1
18	-	-	-	-
19	-	-	-	-
20	L92#120	18	DKBL	3606047C1
21	-	-	-	-
22	-	-	-	-
23	-	-	-	-
24	L92#124	18	TN	3606047C1
25	-	-	-	-
26	-	-	-	-
27	-	-	-	-
28	L5A128	18	YL	3606047C1
29	-	-	-	-
30	L92#130	18	WH	3606047C1
31	L92#131	18	YL	3606047C1
32	-	-	-	-
33	L92#133	18	YL	3606047C1
34	L92#134	18	YL	3606047C1
35	-	-	-	-
36	L92#136	18	OR	3606047C1
37	L92#137	18	WH	3606047C1
38	-	-	-	-
39	L48#139	18	OR	3606047C1
40	L47#140	18	LTGN	3606047C1

CAV	CIRCUIT	GAUGE	COLOR	TERMINAL
41	L92#141	18	TN	3606047C1
42	L92#142	18	WH	3606047C1
43	L92#143	18	DKBL	3606047C1
44	-	-	-	-
45	L92#145	18	OR	3606047C1
46	-	-	-	-
47	-	-	-	-
48	-	-	-	-
49	-	-	-	-
50	-	-	-	-
51	L92#151	18	WH	3606047C1
52	L92#152	18	LTGN	3606047C1
53	-	-	-	-
54	L31#154	18	TN	3606047C1
55	L92#155	18	WH	3606047C1
56	-	-	-	-
57	L92#157	18	WH	3606047C1
58	L92#158	18	LTGN	3606047C1
59	L48#159	18	TN	3606047C1
60	L47#160	18	YL	3606047C1
61	L92#161	18	TN	3606047C1
62	L92#162	18	YL	3606047C1
63	L92#163	18	YL	3606047C1
64	L92#164	18	DKBL	3606047C1
65	L71#165	18	TN	3606047C1
66	-	-	-	-
67	-	-	-	-
68	-	-	-	-
69	L92#169	18	GY	3606047C1
70	L92#170	18	PK	3606047C1
71	L92#171	18	YL	3606047C1
72	-	-	-	-
73	-	-	-	-
74	L92#174	18	DKBL	3606047C1
75	-	-	-	-
76	L92#176	18	YL	3606047C1
77	L92#177	18	LTGN	3606047C1
78	-	-	-	-
79	-	-	-	-
80	L92#180	18	OR	3606047C1

VIW A
(VEHICLE INTERFACE WIRING)
(7205F)

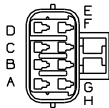

CONNECTOR - 3525872C1
BODY LOCK - 3525873C1
PLUG - 2025431C1

CAV	CIRCUIT	GAUGE	COLOR	TERMINAL	SEAL
A	L92B103	18	YL	1661875C1	3568570C1
B	L92#161	18	TN	1661875C1	3568570C1
C	L92#157	18	WH	1661875C1	3568570C1
D	L92#124	18	TN	1661875C1	3568570C1
E	PLUG	-	-	-	-
F	L92#105	18	TN	1661875C1	3568570C1
G	L92#164	18	DKBL	1661875C1	3568570C1
H	L92#162	18	YL	1661875C1	3568570C1

VIW C
(VEHICLE INTERFACE WIRING)
(7206M)

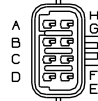

CONNECTOR - 3525874C1
BODY LOCK - 3525875C1
PLUG - 2025431C1

CAV	CIRCUIT	GAUGE	COLOR	TERMINAL	SEAL
A	L92#101	18	DKBL	1667742C1	3568570C1
B	L92#117	18	DKBL	1667742C1	3568570C1
C	L92C103	18	YL	1667742C1	3568570C1
D	L92#143	18	DKBL	1667742C1	3568570C1
E	L92#142	18	WH	1667742C1	3568570C1
F	L92#145	18	OR	1667742C1	3568570C1
G	L92#130	18	WH	1667742C1	3568570C1
H	PLUG	-	-	-	-

B235002829

Figure 35. Connector Composites (7150F, 7205F, 7206M).

CONNECTOR COMPOSITES - (CONTINUED)

J1939 TRANS
(7208M)



CONNECTOR - 1667741C1
BODY LOCK - 1667771C1
PLUG - 2025431C1

CAV	CIRCUIT	GAUGE	COLOR	TERMINAL	SEAL
A	L5C108	18	GN	1661875C1	3568570C1
B	PLUG	-	-	-	-
C	L5C128	18	YL	1661875C1	3568570C1

ABS-6 BLINK
CODE SWITCH
SIDE (7210)



CONNECTOR - 1661256C1

CAV	CIRCUIT	GAUGE	COLOR	TERMINAL
1	-	-	-	-
2	-	-	-	-
4	-	-	-	-
5	A94H	18	GY	1661224C1
6	A94-GB	14	GY	1661226C1

TRANSMISSION CONN
(7250F)

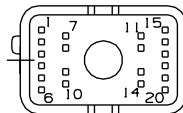

CONNECTOR - 3605715C1
BODY LOCK - 3606532C1

CAV	CIRCUIT	GAUGE	COLOR	TERMINAL
1	L92#111	18	OR	3606047C1
2	L92#155	18	WH	3606047C1
3	L92#177	18	LTGN	3606047C1
4	L92#136	18	OR	3606047C1
5	L92#152	18	LTGN	3606047C1
6	L92#171	18	YL	3606047C1
7	-	-	-	-
8	L92#174	18	DKBL	3606047C1
9	L92#133	18	YL	3606047C1
10	L92#151	18	WH	3606047C1
11	L92#131	18	YL	3606047C1
12	L92#137	18	WH	3606047C1
13	L92#180	18	OR	3606047C1
14	L92#120	18	DKBL	3606047C1
15	L92#116	18	DKBL	3606047C1
16	L92#112	18	PK	3606047C1
17	-	-	-	-
18	L31#154	18	TN	3606047C1
19	L92#158	18	LTGN	3606047C1
20	L92#176	18	YL	3606047C1

ENGINE SPEED SENSOR
(7603M)



CONNECTOR - 3610533C1
BODY LOCK - 3610532C1

CAV	CIRCUIT	GAUGE	COLOR	TERMINAL	SEAL
A	L48#159	18	TN	3554322C1	3554318C1
B	L48#139	18	OR	3554322C1	3554318C1

OUTPUT SPEED SENSOR
(7605M)



CONNECTOR - 3610533C1
BODY LOCK - 3610532C1

CAV	CIRCUIT	GAUGE	COLOR	TERMINAL	SEAL
A	L47#160	18	YL	3554322C1	3554318C1
B	L47#140	18	LTGN	3554322C1	3554318C1

TRANSFER CASE
(7611)



CONNECTOR - 1661778C1
BODY LOCK - 1661874C1

CAV	CIRCUIT	GAUGE	COLOR	TERMINAL	SEAL
A	K47	16	GY	1661875C1	1661872C1
B	K47A	16	GY	1661875C1	1661872C1

NOTE:
MATES WITH CONNECTOR (9750)

B235002834

Figure 36. Connector Composites (7208M, 7210, 7250F, 7603M, 7605M, 7611).

CONNECTOR COMPOSITES - (CONTINUED)

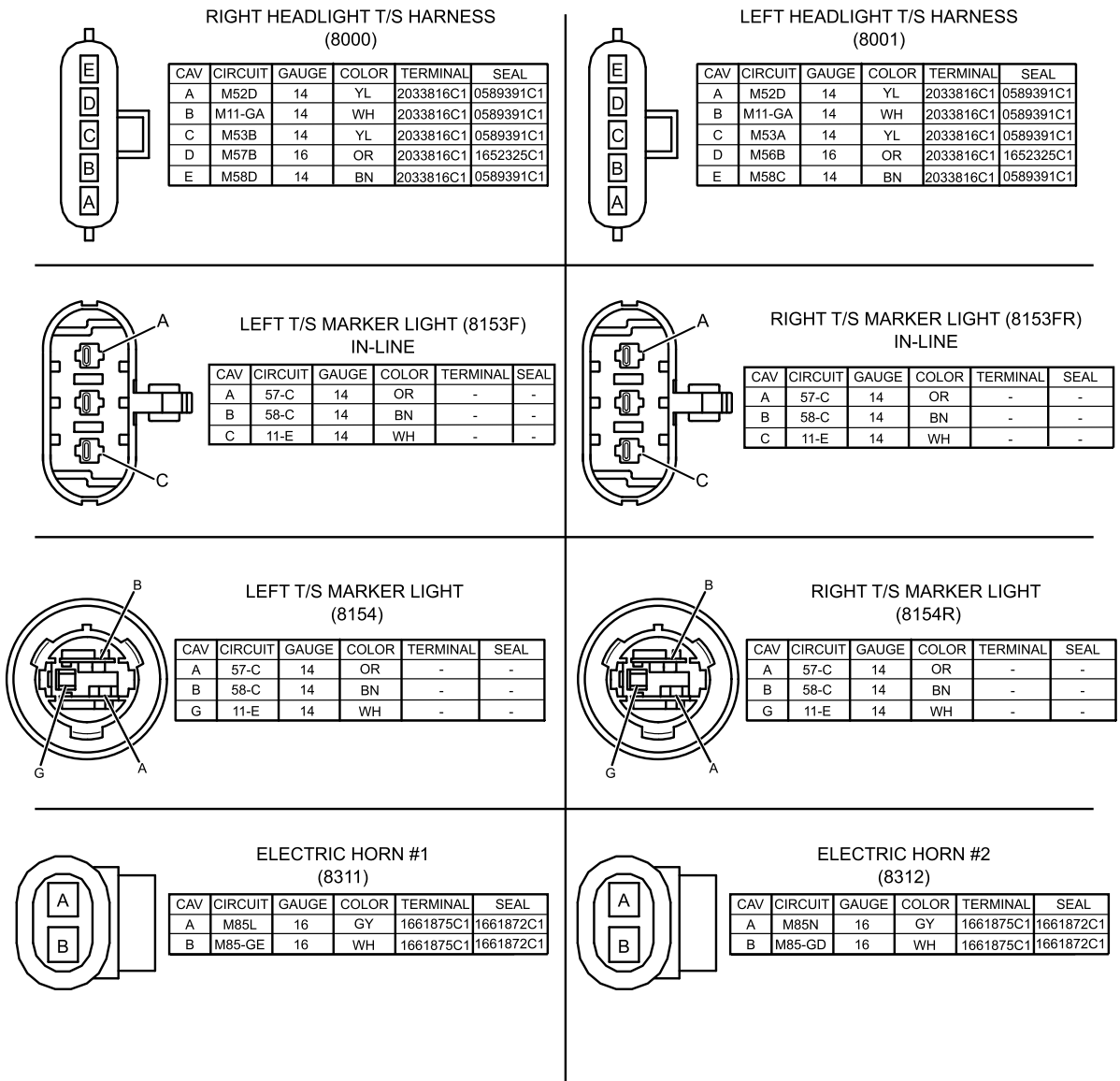

B235005780

Figure 37. Connector Composites (8000, 8001, 8153F, 8153FR, 8154, 8154R, 8311, 8312).

CONNECTOR COMPOSITES - (CONTINUED)

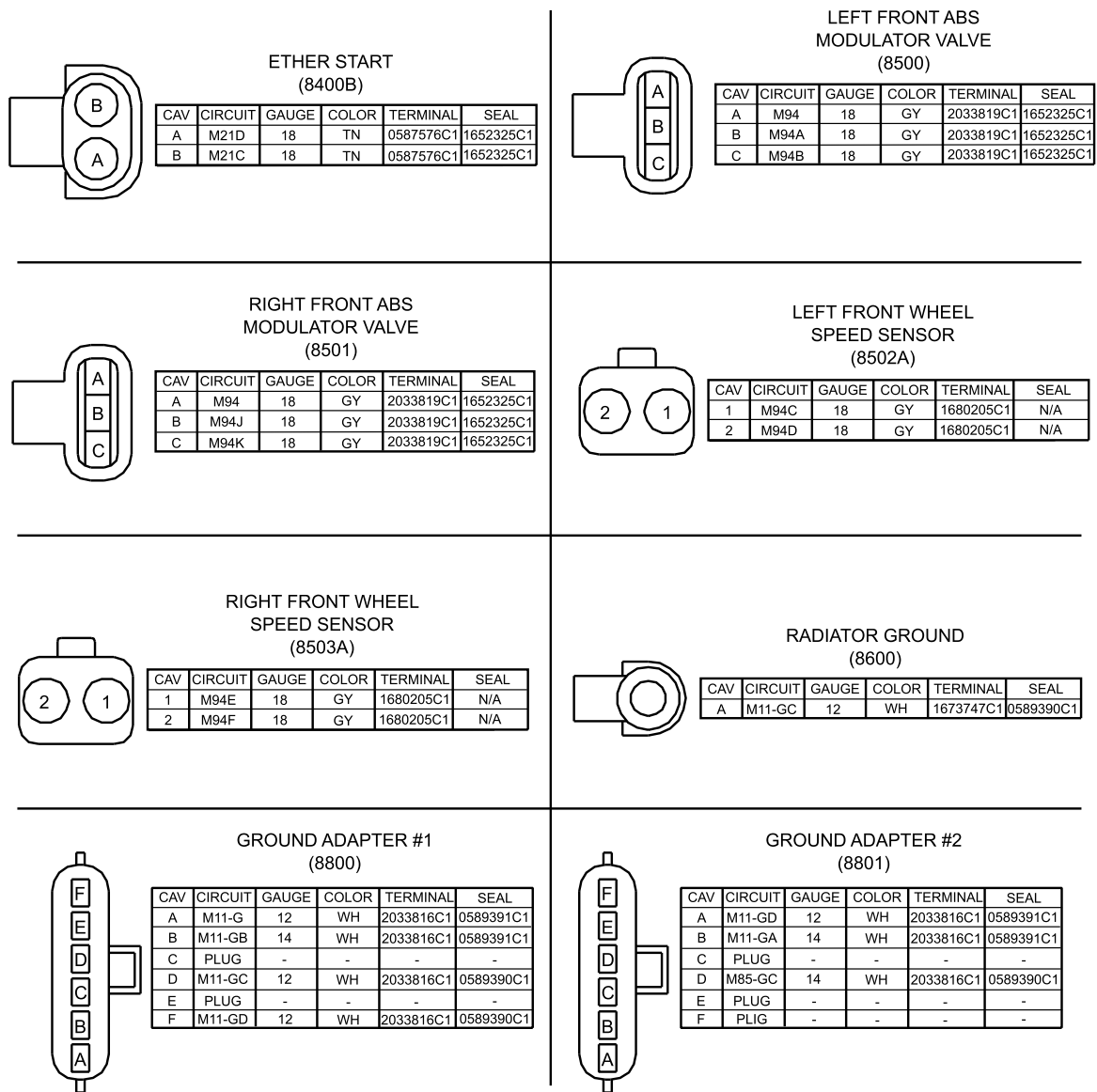

B235005781

Figure 38. Connector Composites (8400B, 8500, 8501, 8502A, 8503A, 8600, 8800, 8801).

CONNECTOR COMPOSITES - (CONTINUED)

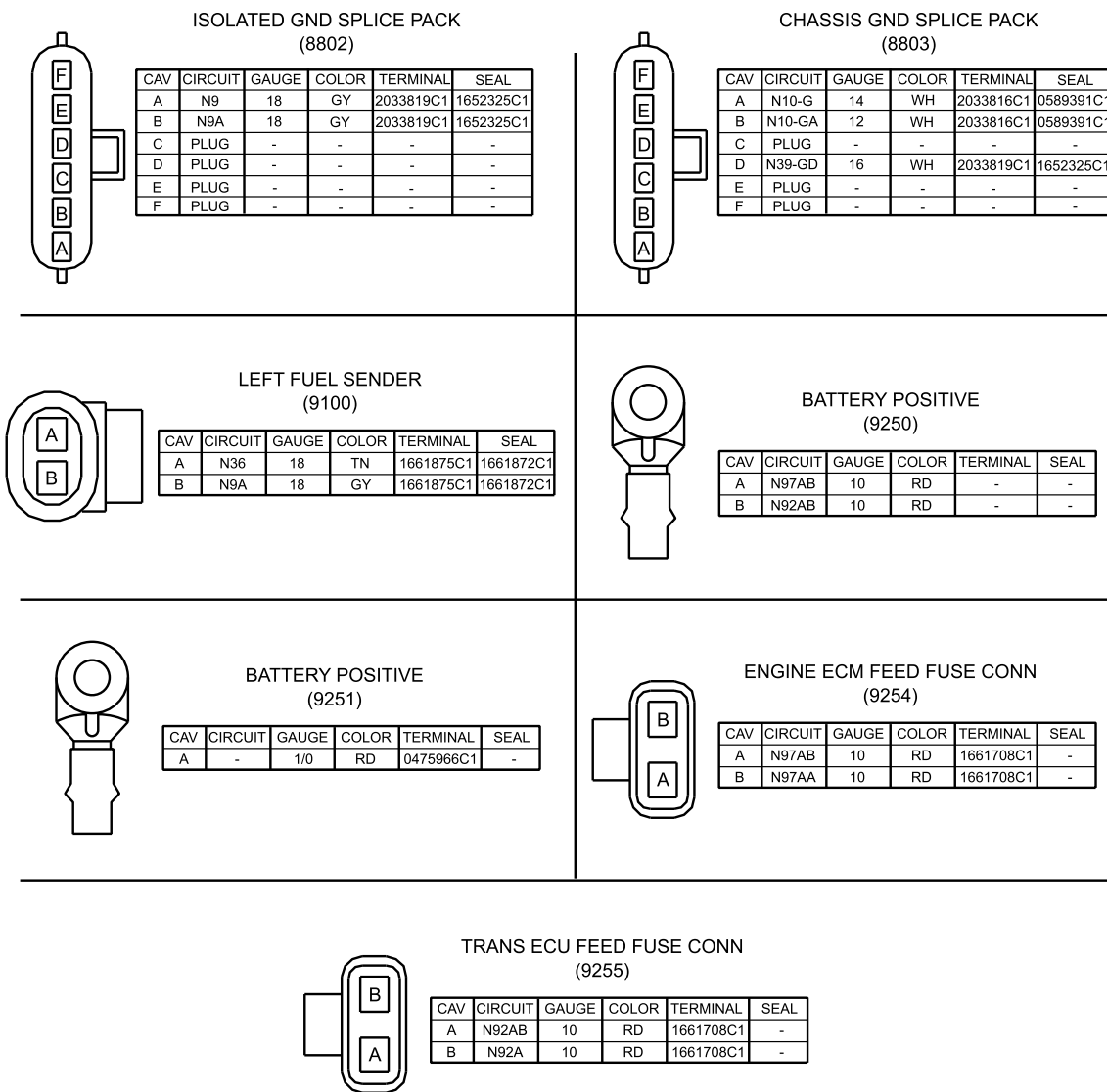

B235005782

Figure 39. Connector Composites (8802, 8803, 9100, 9250, 9251, 9254, 9255).

CONNECTOR COMPOSITES - (CONTINUED)

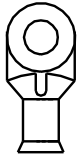

BATTERY NEGATIVE
(9256)

CAV	CIRCUIT	GAUGE	COLOR	TERMINAL	SEAL
A	N97-G	10	RD	-	-
B	N92-G	10	RD	-	-

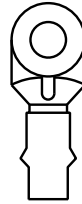

BATTERY NEGATIVE
(9257)

CAV	CIRCUIT	GAUGE	COLOR	TERMINAL	SEAL
A	-	1/0	BK	0475966C1	-

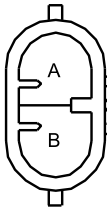

BATTERY CLEAN GROUND CABLE AND HARNESS
(9260M)

CAV	CIRCUIT	GAUGE	COLOR	TERMINAL	SEAL
A	N97-G	10	RD	2025423C1	2025427C1
B	N92-G	10	RD	2025423C1	2025427C1

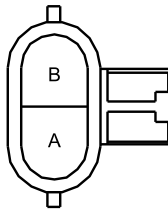

CLEAN POWER AND GROUND HARNESS
(9260F)

CAV	CIRCUIT	GAUGE	COLOR	TERMINAL	SEAL
A	N97-G	10	WH	2031531C1	2025427C1
B	N92-G	14	WH	3540782C1	2025428C1

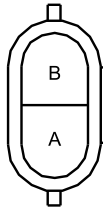

CLEAN POWER AND GROUND HARNESS
(9261M)

CAV	CIRCUIT	GAUGE	COLOR	TERMINAL	SEAL
A	N97AA	10	RD	2031531C1	2025427C1
B	N92A	10	RD	2031531C1	2025427C1

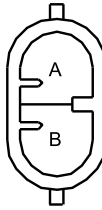

BATTERY CLEAN POWER CABLE AND HARNESS
(9261F)

CAV	CIRCUIT	GAUGE	COLOR	TERMINAL	SEAL
A	N97AA	10	RD	2025423C1	2025427C1
B	N92A	14	RD	2025421C1	2025428C1

STOP, TAIL, TURN & BLACKOUT
(9303A)

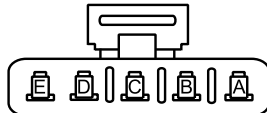

CAV	CIRCUIT	GAUGE	COLOR	TERMINAL	SEAL
A	R71	14	OR	-	-
B	R56	14	OR	-	-
C	R57	14	OR	-	-
D	R68B	14	BN	-	-
E	R10-G	12	WH	-	-

B235005783

Figure 40. Connector Composites (9256, 9257, 9260M, 9260F, 9261M, 9261F, 9303A).

CONNECTOR COMPOSITES - (CONTINUED)

LEFT WHEEL SPEED SENSOR
(9501)



CONNECTOR - 1684261C1
BODY LOCK - 1684263C1

CAV	CIRCUIT	GAUGE	COLOR	TERMINAL
1	R94A	16	GY	1680205C1
2	R94B	16	OR	1680205C1

LEFT MODULATOR
(9502)



CONNECTOR - 1686834C1
BODY LOCK - 1664408C1

CAV	CIRCUIT	GAUGE	COLOR	TERMINAL	SEAL
A	R94E	16	BK	2033819C1	1652325C1
B	R94F	16	RD	2033819C1	1652325C1
C	R94H	16	BN	2033819C1	1652325C1

RIGHT WHEEL SPEED SENSOR
(9503)



CONNECTOR - 1684261C1
BODY LOCK - 1684263C1

CAV	CIRCUIT	GAUGE	COLOR	TERMINAL
1	R94C	16	DK BL	1680205C1
2	R94D	16	YL	1680205C1

RIGHT MODULATOR
(9504)



CONNECTOR - 1686834C1
BODY LOCK - 1664408C1

CAV	CIRCUIT	GAUGE	COLOR	TERMINAL	SEAL
A	R94J	16	PL	2033819C1	1652325C1
B	R94K	16	LT GN	2033819C1	1652325C1
C	R94L	16	LT BL	2033819C1	1652325C1

DASH/CENTER CHASSIS INTERCONNECT
(9700)

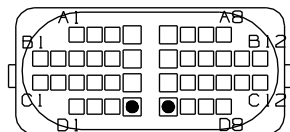

CONNECTOR - 3535310C1
BODY LOCK - 3535311C1 (X2)
BODY LOCK - 3535312C1 (X1)
PLUG 1 - 3535425C1 (ALL CAVITIES EXCEPT THOSE LISTED FOR PLUG 2)
PLUG 2 - 3535938C1 (CAVITIES A4, A5, B6, B7, C6, & C7 ONLY)

NOTES:
MATES WITH CONNECTOR (9714).
CAVITIES NOT LISTED HAVE PLUGS.

CAV	CIRCUIT	GAUGE	COLOR	TERMINAL	SEAL
A3	N94A	16	GY	3535305C1	3535424C1
A4	N71	14	OR	3535934C1	3548945C1
A5	N56	14	OR	3535934C1	3548945C1
A6	N94B	16	OR	3535305C1	3535424C1
A7	N94C	16	DK BL	3535305C1	3535424C1
A8	N94D	16	YL	3535305C1	3535424C1
B1	N94E	16	BK	3535305C1	3535424C1
B2	N94F	16	RD	3535305C1	3535424C1
B3	N94H	16	BN	3535305C1	3535424C1
B4	N94J	16	PL	3535305C1	3535424C1
B5	N94K	16	LT GN	3535305C1	3535424C1
B6	N57	14	OR	3535934C1	3548945C1
B7	N68	14	BN	3535934C1	3548945C1
B8	N94L	16	LT BL	3535305C1	3535424C1
B10	N59J	18	GY	3535305C1	3535424C1
B11	N36	18	TN	3535305C1	3535424C1
B12	N39D	18	GY	3535305C1	3535424C1
C1	N59K	18	GY	3535305C1	3535424C1
C2	N59L	18	GY	3535305C1	3535424C1
C5	N59M	18	GY	3535305C1	3535424C1
C6	N10-G	14	WH	3535934C1	3548945C1
C7	N59H	14	GY	3535934C1	3548945C1
D1	N68	18	BN	3535305C1	3535424C1
D2	N70	18	OR	3535305C1	3535424C1
D8	N9	18	GY	3535305C1	3535424C1

B235002835

Figure 41. Connector Composites (9501, 9502, 9503, 9504, 9700).

CONNECTOR COMPOSITES - (CONTINUED)

DASH/CENTER CHASSIS INTERCONNECT
(9714)

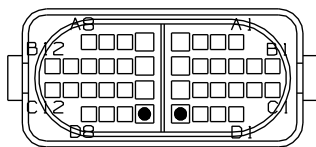

- CONNECTOR - 3535306C1
- BODY LOCK - 3535307C1 (X2)
- BODY LOCK - 3535309C1 (X1)
- CONN SEAL - 3535308C1
- PLUG 1 - 3535425C1 (ALL CAVITIES EXCEPT THOSE LISTED FOR PLUG 2)
- PLUG 2 - 3535938C1 (CAVITIES A4, A5, B6 B7, C6, & C7 ONLY)

NOTES:
MATES WITH CONNECTOR (9700).
CAVITIES NOT LISTED HAVE PLUGS.

CAV	CIRCUIT	GAUGE	COLOR	TERMINAL	SEAL
A3	J94AB	18	GY	3535303C1	3535424C1
A4	J71B	18	OR	3535930C1	3535936C1
A5	J56B	16	OR	3535930C1	3535936C1
A6	J94AA	18	OR	3535030C1	3535424C1
A7	J94AL	18	DK BL	3535303C1	3535424C1
A8	J94AK	18	YL	3535303C1	3535424C1
B1	J94AC	18	BK	3535303C1	3535424C1
B2	J94AD	18	RD	3535303C1	3535424C1
B3	J94AE	18	BN	3535303C1	3535424C1
B4	J94AF	18	VT	3535303C1	3535424C1
B5	J94AH	18	LT GN	3535303C1	3535424C1
B6	J57B	16	OR	3535930C1	3535936C1
B7	J68K	14	BN	3535931C1	3548945C1
B8	J94AJ	18	LT BL	3535303C1	3535424C1
B10	J59A	18	GY	3535303C1	3535424C1
B11	J36A	18	TN	3535303C1	3535424C1
B12	J39A	16	GY	3535303C1	3535424C1
C1	J59B	18	GY	3535303C1	3535424C1
C2	J59C	18	GY	3535303C1	3535424C1
C5	J59D	18	GY	3535303C1	3535424C1
C6	J11-GA	14	WH	3535931C1	3548945C1
C7	J59E	14	GY	3535931C1	3548945C1
C8	J39B	16	GY	3535303C1	3535424C1
D1	J68BA	18	BN	3535303C1	3535424C1
D2	J70BE	18	OR	3535303C1	3535424C1
D6	J87CA	18	GY	3535303C1	3535424C1
D8	J9G	18	GY	3535303C1	3535424C1

TRAILER SOCKET #1
DASH HARNESS
(9715P)

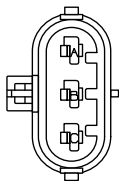

- CONNECTOR - 1667732C1
- BODY LOCK - 1667734C1
- PLUG - 1675451C1

CAV	CIRCUIT	GAUGE	COLOR	TERMINAL	SEAL
A	J70B	14	RD	1667736C1	1671603C1
B	J70BF	14	OR	1667736C1	1671603C1
C	J58BF	14	BN	1667736C1	1671603C1

TRAILER SOCKET #1
CENTER CHASSIS
(9715M)

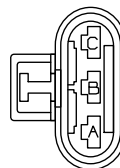

- CONNECTOR - 1667733C1
- BODY LOCK - 1667734C1
- PLUG - 1675451C1

CAV	CIRCUIT	GAUGE	COLOR	TERMINAL	SEAL
A	N70D	10	RD	1667737C1	1667735C1
B	N68D	10	BN	1667737C1	1667735C1
C	N94D	10	GY	1667737C1	1667735C1

← MATES WITH →

B235002833

Figure 42. Connector Composites (9714, 9715, 9715M).

CONNECTOR COMPOSITES - (CONTINUED)

TRAILER SOCKET #1
CENTER CHASSIS
(9715)

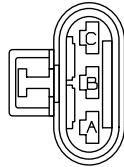

CONNECTOR - 1667733C1
BODY LOCK - 1667734C1
PLUG - 1675451C1

CAV	CIRCUIT	GAUGE	COLOR	TERMINAL	SEAL
A	N70D	10	RD	1667737C1	1667735C1
B	N68D	10	BN	1667737C1	1667735C1
C	N94D	10	BY	1667737C1	1667735C1

TRAILER SOCKET #1
REAR CHASSIS
(9715F)

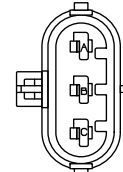

CONNECTOR - 1667732C1
BODY LOCK - 1667734C1
PLUG - 1675451C1

CAV	CIRCUIT	GAUGE	COLOR	TERMINAL	SEAL
A	R70A	10	RD	2025425C1	1667735C1
B	R68A	10	BN	2025425C1	1667735C1
C	R94A	10	DK BL	2025425C1	1667735C1

MATES WITH

TRAILER SOCKET #2
DASH HARNESS
(9716P)

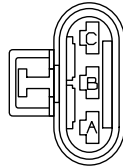

CONNECTOR - 1667733C1
BODY LOCK - 1667734C1
PLUG - 1675451C1

CAV	CIRCUIT	GAUGE	COLOR	TERMINAL	SEAL
A	J68F	14	BN	1667738C1	1671603C1
B	J56C	14	OR	1667738C1	1671603C1
C	J57C	14	GY	1667738C1	1671603C1

TRAILER SOCKET #2
CENTER CHASSIS
(9716F)

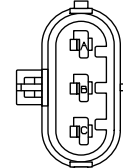

CONNECTOR - 1667732C1
BODY LOCK - 1667734C1
PLUG - 1675451C1

CAV	CIRCUIT	GAUGE	COLOR	TERMINAL	SEAL
A	N58D	10	BN	2025425C1	1667735C1
B	N56D	10	YL	2025425C1	1667735C1
C	N57D	10	LT GN	2025425C1	1667735C1

MATES WITH

TRAILER SOCKET 2
CENTER CHASSIS
(9716)

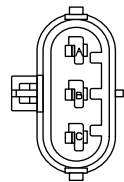

CONNECTOR - 1667732C1
BODY LOCK - 1667734C1
PLUG - 1675451C1

CAV	CIRCUIT	GAUGE	COLOR	TERMINAL	SEAL
A	N58D	10	BN	2025425C1	1667735C1
B	N56D	10	YL	2025425C1	1667735C1
C	N57D	10	LT GN	2025425C1	1667735C1

TRAILER SOCKET 2
REAR CHASSIS
(9716M)

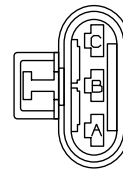

CONNECTOR - 1667733C1
BODY LOCK - 1667734C1
PLUG - 1675451C1

CAV	CIRCUIT	GAUGE	COLOR	TERMINAL	SEAL
A	R58A	10	BK	1667737C1	1667735C1
B	R56A	10	YL	1667737C1	1667735C1
C	R57A	10	LT GN	1667737C1	1667735C1

MATES WITH

B235002836

Figure 43. Connector Composites (9715, 9715F, 9716P, 9716F, 9716, 9716M).

CONNECTOR COMPOSITES - (CONTINUED)

TRAILER GROUND
(9717)



CONNECTOR - 3517441C1

CAV	CIRCUIT	GAUGE	COLOR	TERMINAL
A	N10D	8	WH	3517439C1

TRAILER GROUND
(9717F)



CONNECTOR - 3517817C1

CAV	CIRCUIT	GAUGE	COLOR	TERMINAL
A	R10A	8	WH	3517818C1

← MATES WITH →

TRAILER SOCKET GROUND
(9717M)

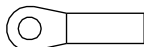

CIRCUIT	GAUGE	COLOR	TERMINAL	SLEEVE
N10D	8	WH	2034790C1	2644005R1

REAR CHASSIS HARNESS
BLACKOUT LIGHTING
(9720)

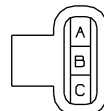

CONNECTOR - 1686834C1
BODY LOCK - 1664408C1
PLUG - 0587579C1

CAV	CIRCUIT	GAUGE	COLOR	TERMINAL	SEAL
A	R70	18	OR	2033819C1	1652325C1
B	R68	18	BN	2033819C1	1652325C1
C	PLUG	-	-	-	-

TRAILER AUXILIARY POWER
(9722F)



CONNECTOR - 1664531C1
BODY LOCK - 1675053C1

← MATES WITH →



CONNECTOR - 1669834C1
BODY LOCK - 1675053C1

CAV	CIRCUIT	GAUGE	COLOR	TERMINAL	SEAL
A	N72EB	10	LT GN	1687847C1	0589390C1

CAV	CIRCUIT	GAUGE	COLOR	TERMINAL	SEAL
A	R72	10	LT GN	1687848C1	0589390C1

FRONT TRAILER SOCKET #1
(9723)



CONNECTOR - 3553961C1
BODY LOCK - 3554019C1
PLUG - 0587579C1

CAV	CIRCUIT	GAUGE	COLOR	TERMINAL	SEAL
A	94	14	GY	2033912C1	0589391C1
B	PLUG	-	-	-	-
C	72	14	GN	2033912C1	0589391C1

FRONT TRAILER SOCKET #2
(9724)

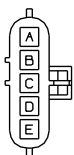

CONNECTOR - 3553961C1
BODY LOCK - 3554019C1
PLUG - 0587579C1

CAV	CIRCUIT	GAUGE	COLOR	TERMINAL	SEAL
A	58	14	BN	2033912C1	0589391C1
B	56	14	YL	2033912C1	0589391C1
C	57	14	DK BL	2033912C1	0589391C1
D	70	14	RD	2033912C1	0589391C1
E	68	14	BN	2033912C1	0589391C1

B235002837

Figure 44. Connector Composites (9717, 9717F, 9717M, 9720, 9722, 9723, 9724).

CONNECTOR COMPOSITES - (CONTINUED)

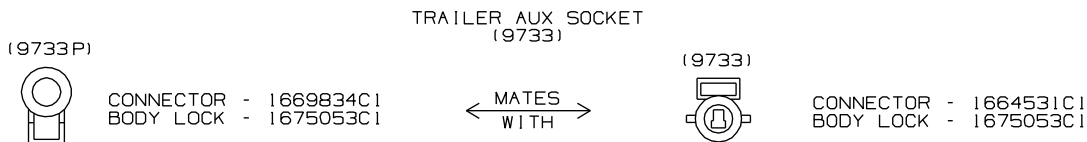

CAV	CIRCUIT	GAUGE	COLOR	TERMINAL	SEAL
A	J72A	10	OR	1687848C1	0589390C1

CAV	CIRCUIT	GAUGE	COLOR	TERMINAL	SEAL
A	N72EB	10	LT GN	1687847C1	0589390C1

AIR SOLENOID 4-PACK
(9736)

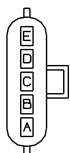

CONNECTOR - 1661375C2
BODY LOCK - 1661376C1
PLUG - 0587579C1

CAV	CIRCUIT	GAUGE	COLOR	TERMINAL	SEAL
A	N59H	14	GY	2033816C1	0589391C1
B	N59J	18	GY	2033819C1	1652325C1
C	N59K	18	GY	2033819C1	1652325C1
D	N59L	18	GY	2033819C1	1652325C1
E	N59M	18	GY	2033819C1	1652325C1

TRANSFER CASE
(9750)



CONNECTOR - 3543888C1
BODY LOCK - 1661874C1

CAV	CIRCUIT	GAUGE	COLOR	TERMINAL	SEAL
A	N47A	16	GY	1667742C1	1661872C1
B	N47B	16	GY	1667742C1	1661872C1

NOTE: MATES WITH CONNECTOR (7611)

TRANSFER CASE SWITCH PIGTAIL
(9754)



CONNECTOR - 0587567C91

CAV	CIRCUIT	GAUGE	COLOR	TERMINAL	SEAL
A	N42	18	GY	0587578C1	1652325C1
B	N42-G	18	WH	2033911C1	1652325C1

TRANSFER CASE
(9755)



CONNECTOR - 2036583C1

CAV	CIRCUIT	GAUGE	COLOR	TERMINAL
A	N47A	16	GY	2036586C1
B	N47B	16	GY	2036586C1

TRAILER SOCKET GROUND
(9778F)



CONNECTOR - 3517817C1

CAV	CIRCUIT	GAUGE	COLOR	TERMINAL
A	R10A	8	WH	3517818C1

TRAILER SOCKET 2
(9779F)

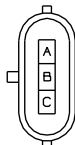

CONNECTOR - 1667732C1
BODY LOCK - 1667734C1
PLUC - 1675451C1

CAV	CIRCUIT	GAUGE	COLOR	TERMINAL	SEAL
A	R58A	10	BK	2025425C1	1667735C1
B	R56A	10	YL	2025425C1	1667735C1
C	R57A	10	LT GN	2025425C1	1667735C1

B235002838

Figure 45. Connector Composites (9733, 9733P, 9736, 9750, 9754, 9755, 9778F, 9779F).

CONNECTOR COMPOSITES - (CONTINUED)

TRAILER SOCKET 1
(9780M)

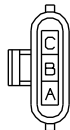

CONNECTOR - 1667733C1
BODY LOCK - 1667734C1
PLUG - 1675451C1

CAV	CIRCUIT	GAUGE	COLOR	TERMINAL	SEAL
A	R70A	10	RD	1667737C1	1667735C1
B	R68A	10	BN	1667737C1	1667735C1
C	R94A	10	DK BL	1667737C1	1667735C1

TRAILER AUX POWER
(9783)



CONNECTOR - 1669834C1
BODY LOCK - 1675053C1

CAV	CIRCUIT	GAUGE	COLOR	TERMINAL	SEAL
A	R72	10	LT GN	1687848C1	0589390C1

CONNECTION TO CENTER HARNESS
(9800M)

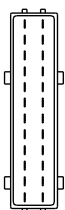

CONNECTOR - 3558022C1
BODY LOCK - 3558056C1
PLUG - 3532129C1

← MATES WITH →

CONNECTION TO REAR CHASSIS HARNESS
(9800F)

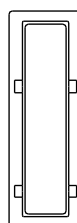

CONNECTOR - 3558026C1
BODY LOCK - 3558056C1
PLUG - 3532129C1

CAV	CIRCUIT	GAUGE	COLOR	TERMINAL	SEAL
1	R71	14	OR	3559037C1	3575783C1
2	R56	14	OR	3559037C1	3575783C1
3	R57	14	OR	3559037C1	3575783C1
4	R68	14	BN	3559037C1	3575783C1
5	R68	18	BN	3559036C1	3509903C1
6	R70	18	OR	3559036C1	3509903C1
7	PLUG	-	-	-	-
8	PLUG	-	-	-	-
9	PLUG	-	-	-	-
10	PLUG	-	-	-	-
11	PLUG	-	-	-	-
12	R10-G	12	WH	3559037C1	3575783C1
13	R94A	16	GY	3559037C1	3509903C1
14	R94B	16	OR	3559037C1	3509903C1
15	R94C	16	DK BL	3559037C1	3509903C1
16	R94D	16	YL	3559037C1	3509903C1
17	R94E	16	BK	3559037C1	3509903C1
18	R94F	16	RD	3559037C1	3509903C1
19	R94H	16	BN	3559037C1	3509903C1
20	R94J	16	PL	3559037C1	3509903C1
21	R94K	16	LT GN	3559037C1	3509903C1
22	R94L	16	LT BL	3559037C1	3509903C1
23	PLUG	-	-	-	-
24	PLUG	-	-	-	-

CAV	CIRCUIT	GAUGE	COLOR	TERMINAL	SEAL
1	N71	14	OR	3559035C1	3575783C1
2	N56	14	OR	3559035C1	3575783C1
3	N57	14	OR	3559035C1	3575783C1
4	N68	14	BN	3559035C1	3575783C1
5	N68	18	BN	3509874C1	3509903C1
6	N70	18	OR	3509874C1	3509903C1
7	PLUG	-	-	-	-
8	PLUG	-	-	-	-
9	PLUG	-	-	-	-
10	PLUG	-	-	-	-
11	PLUG	-	-	-	-
12	N10-GA	12	WH	3559035C1	3575783C1
13	N94A	16	GY	3559035C1	3509903C1
14	N94B	16	OR	3559035C1	3509903C1
15	N94C	16	DK BL	3559035C1	3509903C1
16	N94D	16	YL	3559035C1	3509903C1
17	N94E	16	BK	3559035C1	3509903C1
18	N94F	16	RD	3559035C1	3509903C1
19	N94H	16	BN	3559035C1	3509903C1
20	N94J	16	PL	3559035C1	3509903C1
21	N94K	16	LT GN	3559035C1	3509903C1
22	N94L	16	LT BL	3559035C1	3509903C1
23	PLUG	-	-	-	-
24	PLUG	-	-	-	-

B235002839

Figure 46. Connector Composites (9780M, 9783, 9800F, 9800M).

CONNECTOR COMPOSITES - (CONTINUED)

AIR DRYER
(9900C)

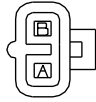

CONNECTOR - 1673790C1
 BODY LOCK - 1673791C1
 PLUG - 0587579C1

CAV	CIRCUIT	GAUGE	COLOR	TERMINAL	SEAL
A	N39D	18	GY	2033819C1	1652325C1
B	N39-GD	16	WH	2033819C1	1652325C1

BLACKOUT LIGHTING
(9916)

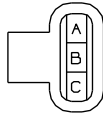

CONNECTOR - 1686834C1
 BODY LOCK - 1664408C1
 PLUG - 0587579C1

CAV	CIRCUIT	GAUGE	COLOR	TERMINAL	SEAL
A	MU54A	16	BN	2033819C1	1652325C1
B	MU53C	16	YL	2033819C1	1652325C1
C	MU52	16	YL	2033819C1	1652325C1

BLACKOUT MARKER
(9917)



CONNECTOR - 1664531C1
 BODY LOCK - 1675053C1

CAV	CIRCUIT	GAUGE	COLOR	TERMINAL	SEAL
A	MU54B	16	BN	2033819C1	1652325C1

B235002841

Figure 47. Connector Composites (9900C, 9916, 9917).

CONNECTOR COMPOSITES - (CONTINUED)

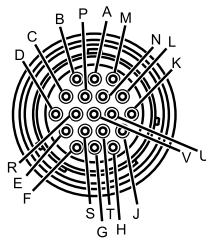

FSS CONTROL PANEL (C1)

CAV	CIRCUIT	GAUGE	COLOR	TERMINAL	SEAL
A	-	-	-	-	-
B	-	-	-	-	-
C	-	-	-	-	-
D	-	-	-	-	-
E	-	-	-	-	-
F	-	-	-	-	-
G	-	-	-	-	-
H	-	-	-	-	-
I	-	-	-	-	-
J	-	-	-	-	-
K	-	-	-	-	-
L	-	-	-	-	-
M	-	-	-	-	-
N	-	-	-	-	-
P	-	-	-	-	-
R	-	-	-	-	-
S	-	-	-	-	-
T	-	-	-	-	-
U	-	-	-	-	-
V	-	-	-	-	-

ENGINE FIRE SUPPRESSION CYLINDER (C2)

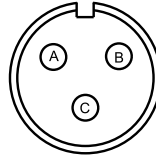

CAV	CIRCUIT	GAUGE	COLOR	TERMINAL	SEAL
A	-	-	-	-	-
B	-	-	-	-	-
C	-	-	-	-	-
-	-	-	-	-	-

INTERNAL FIRE CYLINDER (C3)

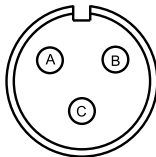

CAV	CIRCUIT	GAUGE	COLOR	TERMINAL	SEAL
A	-	-	-	-	-
B	-	-	-	-	-
C	-	-	-	-	-
-	-	-	-	-	-

FUEL TANK FIRE CYLINDER (C4)

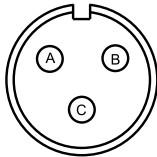

CAV	CIRCUIT	GAUGE	COLOR	TERMINAL	SEAL
A	-	-	-	-	-
B	-	-	-	-	-
C	-	-	-	-	-
-	-	-	-	-	-

TIRE FIRE SUPPRESSION CYLINDER (C6)

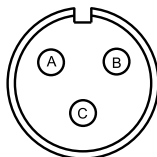

CAV	CIRCUIT	GAUGE	COLOR	TERMINAL	SEAL
A	-	-	-	-	-
B	-	-	-	-	-
C	-	-	-	-	-
-	-	-	-	-	-

ENGINE FIRE HEAT DETECTOR (C7)

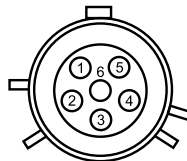

CAV	CIRCUIT	GAUGE	COLOR	TERMINAL	SEAL
1	21V IGN	-	-	-	-
2	GND	-	-	-	-
3	-	-	-	-	-
4	24V B+	-	-	-	-
5	FSS SWITCHED 24V	-	-	-	-
6	-	-	-	-	-

B235005773

Figure 48. Connector Composites (C1, C2, C3, C4, C6, C7).

CONNECTOR COMPOSITES - (CONTINUED)

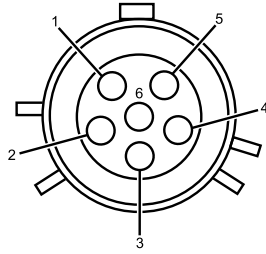

CABIN FIRE HEAT DETECTOR
(C8)

CAV	CIRCUIT	GAUGE	COLOR	TERMINAL	SEAL
1	24V IGN	-	-	-	-
2	GND	-	-	-	-
3	-	-	-	-	-
4	24V B+	-	-	-	-
5	FSS SWITCHED 24V	-	-	-	-
6	-	-	-	-	-

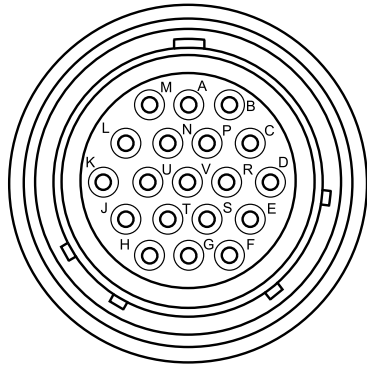

CABIN BULKHEAD PASS THROUGH
(C9)

CAV	CIRCUIT	GAUGE	COLOR	TERMINAL	SEAL
A	-	-	-	-	-
B	-	-	-	-	-
C	-	-	-	-	-
D	-	-	-	-	-
E	-	-	-	-	-
F	-	-	-	-	-
G	-	-	-	-	-
H	-	-	-	-	-
J	-	-	-	-	-
K	-	-	-	-	-
L	-	-	-	-	-
M	-	-	-	-	-
N	-	-	-	-	-
P	-	-	-	-	-
R	-	-	-	-	-
S	-	-	-	-	-
T	-	-	-	-	-
U	-	-	-	-	-
V	-	-	-	-	-

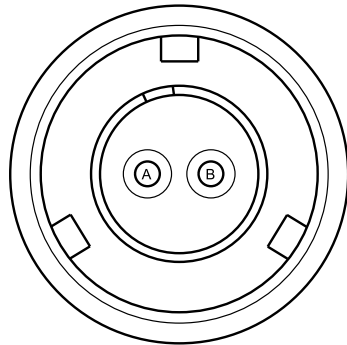

FIRE SUPPRESSION HARNESS AT PDM
(C10)

CAV	CIRCUIT	GAUGE	COLOR	TERMINAL	SEAL
A	-	-	-	-	-
B	-	-	-	-	-

B235005774

Figure 49. Connector Composites (C8, C9, C10).

CONNECTOR COMPOSITES - (CONTINUED)

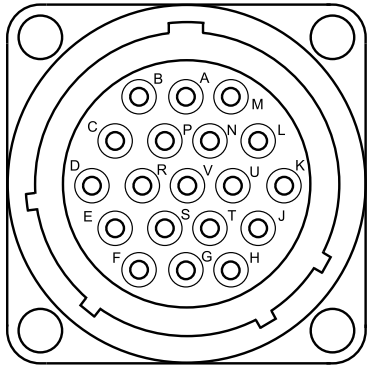

ENGINE BULKHEAD PASS THROUGH
(C11)

CAV	CIRCUIT	GAUGE	COLOR	TERMINAL	SEAL
A	-	-	-	-	-
B	-	-	-	-	-
C	-	-	-	-	-
D	-	-	-	-	-
E	-	-	-	-	-
F	-	-	-	-	-
G	-	-	-	-	-
H	-	-	-	-	-
J	-	-	-	-	-
K	-	-	-	-	-
L	-	-	-	-	-
M	-	-	-	-	-
N	-	-	-	-	-
P	-	-	-	-	-
R	-	-	-	-	-
S	-	-	-	-	-
T	-	-	-	-	-
U	-	-	-	-	-
V	-	-	-	-	-

B235005775

Figure 50. Connector Composites (C11).

CONNECTOR COMPOSITES - (CONTINUED)

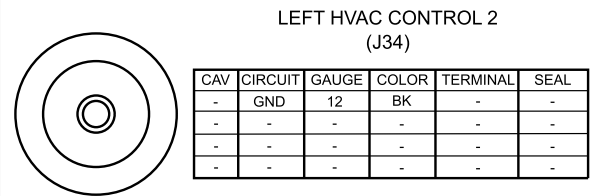
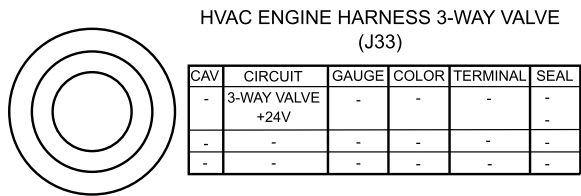
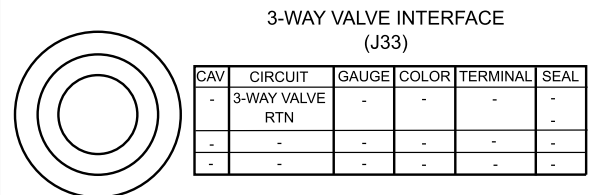
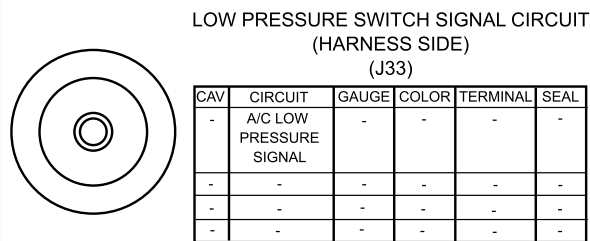
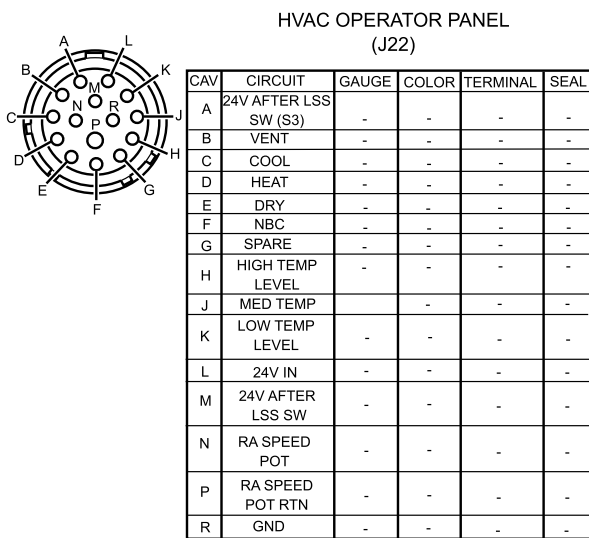
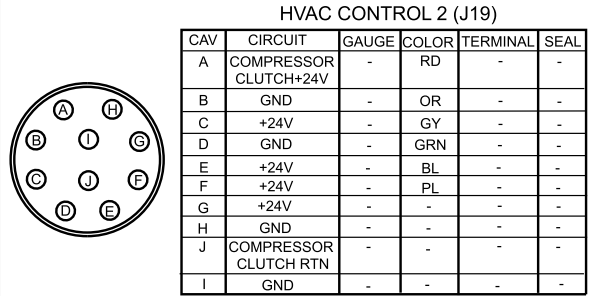
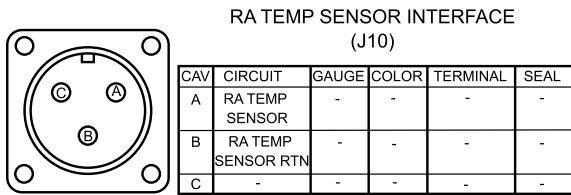
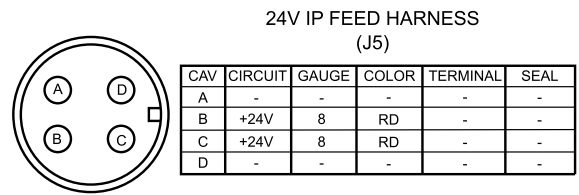
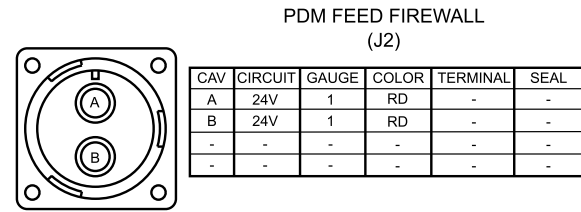

B235005741

Figure 51. Connector Composites (J2, J5, J10, J19, J22, J33, J33, J33, J34).

CONNECTOR COMPOSITES - (CONTINUED)

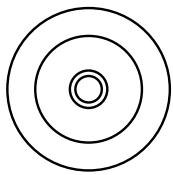

RIGHT HVAC CONTROL 2
(J34)

CAV	CIRCUIT	GAUGE	COLOR	TERMINAL	SEAL
-	GND	12	BK	-	-

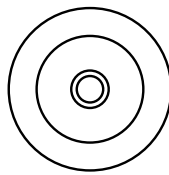

LEFT CONDENSER CONTROL
(J34)

CAV	CIRCUIT	GAUGE	COLOR	TERMINAL	SEAL
-	+24V	12	BK	-	-

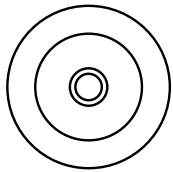

RIGHT CONDENSER CONTROL
(J34)

CAV	CIRCUIT	GAUGE	COLOR	TERMINAL	SEAL
-	+24V	12	BK	-	-

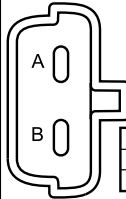

AIR CONDITIONING COMPRESSOR
(J36)

CAV	CIRCUIT	GAUGE	COLOR	TERMINAL	SEAL
A	COMPRESSOR CLUTCH RTN	-	-	-	-
B	COMPRESSOR CLUTCH +24V	-	-	-	-

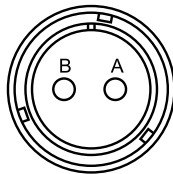

HVAC CONTROL POWER
(P1)

CAV	CIRCUIT	GAUGE	COLOR	TERMINAL	SEAL
A	GND	-	-	-	-
B	24V	-	-	-	-

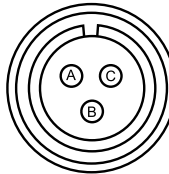

LEFT CONDENSER CONTROL
(P3)

CAV	CIRCUIT	GAUGE	COLOR	TERMINAL	SEAL
A	+24V	-	-	-	-
B	GND	-	-	-	-
C	-	-	-	-	-

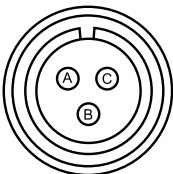

RIGHT CONDENSER CONTROL
(P4)

CAV	CIRCUIT	GAUGE	COLOR	TERMINAL	SEAL
A	+24V	-	-	-	-
B	GND	-	-	-	-
C	-	-	-	-	-

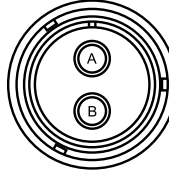

PDM FEED HARNESS
(P4)

CAV	CIRCUIT	GAUGE	COLOR	TERMINAL	SEAL
A	24V	1	RD	-	-
B	24V	1	RD	-	-

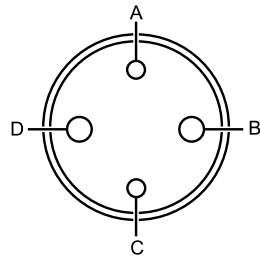

RA MOTOR HARNESS AT CCU
(P5)

CAV	CIRCUIT	GAUGE	COLOR	TERMINAL	SEAL
B	+24V PWM	-	-	-	-
D	GND	-	-	-	-

B235005742

Figure 52. Connector Composites (J34, J34, J34, J36, P1, P3, P4, P4, P5).

CONNECTOR COMPOSITES - (CONTINUED)

HVAC CONTROL IN HARNESS AT CCU
(P6)

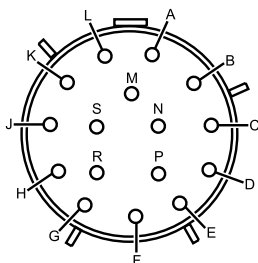

CAV	CIRCUIT	GAUGE	COLOR	TERMINAL	SEAL
A	HIGH IDLE SPEED REQUEST	-	-	-	-
B	LOW PRESSURE SW GND	-	-	-	-
C	LOW PRESSURE SW SIGNAL RTN	-	-	-	-
D	COMPRESSOR CLUTCH	-	-	-	-
E	-	-	-	-	-
F	-	-	-	-	-
G	-	-	-	-	-
H	3 WAY VALVE RETURN	-	-	-	-
J	COMPRESSOR CLUTCH RTN	-	-	-	-
K	-	-	-	-	-
L	SPARE	-	-	-	-
M	-	-	-	-	-
N	CONDENSER FAN ON	-	-	-	-
P	-	-	-	-	-
R	3 WAY VALVE	-	-	-	-
S	GND	-	-	-	-

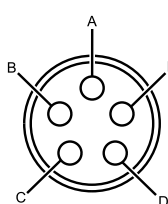

RA MOTOR
(P8)

CAV	CIRCUIT	GAUGE	COLOR	TERMINAL	SEAL
A	-	-	-	-	-
B	+24V PWM	-	-	-	-
C	-	-	-	-	-
D	GND	-	-	-	-
E	GND	-	-	-	-

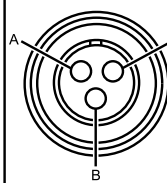

RA TEMP SENSOR
(P10)

CAV	CIRCUIT	GAUGE	COLOR	TERMINAL	SEAL
A	RA TEMP SENSOR	-	-	-	-
B	RA TEMP SENSOR RTN	-	-	-	-
C	-	-	-	-	-

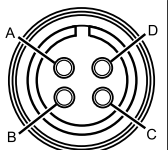

TRINARY SWITCH
(P12)

CAV	CIRCUIT	GAUGE	COLOR	TERMINAL	SEAL
A	MEDIUM PRESSURE SIGNAL	-	-	-	-
B	HI/LO PRESSURE SIGNAL	-	-	-	-
C	+24V	-	-	-	-
D	+24V	-	-	-	-

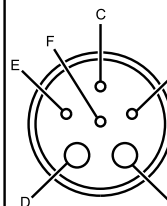

FA MOTOR HARNESS AT CCU
(P14)

CAV	CIRCUIT	GAUGE	COLOR	TERMINAL	SEAL
A	GND	-	-	-	-
B	-	-	-	-	-
C	-	-	-	-	-
D	+24V	-	-	-	-
E	-	-	-	-	-
F	-	-	-	-	-

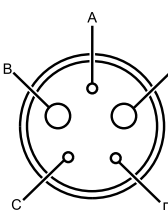

RA MOTOR
(P17)

CAV	CIRCUIT	GAUGE	COLOR	TERMINAL	SEAL
A	GND	-	-	-	-
B	-	-	-	-	-
C	-	-	-	-	-
D	+24V	-	-	-	-
E	-	-	-	-	-

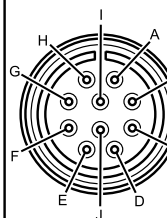

HVAC
(P19)

CAV	CIRCUIT	GAUGE	COLOR	TERMINAL	SEAL
A	COMPRESSOR CLUTCH	-	-	-	-
B	GND	-	-	-	-
C	+24V	-	-	-	-
D	GND	-	-	-	-
E	+24V	-	-	-	-
F	+24V	-	-	-	-
G	+24V	-	-	-	-
H	GND	-	-	-	-
J	GND	-	-	-	-
I	COMPRESSOR CLUTCH RTN	-	-	-	-

B235005743

Figure 53. Connector Composites (P6, P8, P10, P12, P14, P17, P19).

CONNECTOR COMPOSITES - (CONTINUED)

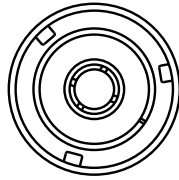

HVAC CONTROL POWER
(P20)

CAV	CIRCUIT	GAUGE	COLOR	TERMINAL	SEAL
A	+24V	-	-	-	-

HVAC OPERATOR PANEL
HARNESS AT CCU
(P21)

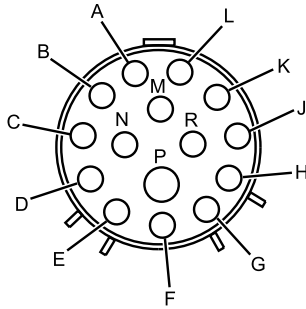

CAV	CIRCUIT	GAUGE	COLOR	TERMINAL	SEAL
A	-	-	-	-	-
B	VENT	-	-	-	-
C	COOL	-	-	-	-
D	HEAT	-	-	-	-
E	DRY	-	-	-	-
F	NBC	-	-	-	-
G	SPARE	-	-	-	-
H	HIGH TEMP LEVEL	-	-	-	-
J	MED TEMP	-	-	-	-
K	LOW TEMP LEVEL	-	-	-	-
L	24V IN	-	-	-	-
M	24V AFTER LSS SW	-	-	-	-
N	RA SPEED POT.	-	-	-	-
P	RA SPEED POT RTN.	-	-	-	-
R	GND	-	-	-	-

HVAC OPERATOR PANEL
(P22)

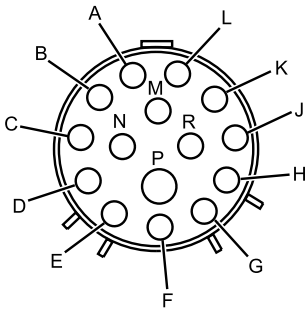

CAV	CIRCUIT	GAUGE	COLOR	TERMINAL	SEAL
A	24V AFTER-LSS SW (S3)	-	-	-	-
B	VENT	-	-	-	-
C	COOL	-	-	-	-
D	HEAT	-	-	-	-
E	DRY	-	-	-	-
F	NBC	-	-	-	-
G	SPARE	-	-	-	-
H	HIGH TEMP LEVEL	-	-	-	-
J	MED TEMP	-	-	-	-
K	LOW TEMP LEVEL	-	-	-	-
L	24V IN	-	-	-	-
M	24V AFTER LSS SW	-	-	-	-
N	RA SPEED POT	-	-	-	-
P	RA SPEED POT RTN.	-	-	-	-
R	GND	-	-	-	-

HVAC CONTROL HARNESS AT CCU
(P23)

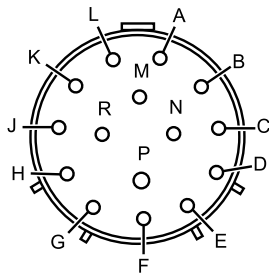

CAV	CIRCUIT	GAUGE	COLOR	TERMINAL	SEAL
A	CLUTCH +24V (AFTER FREEZE SW)	-	-	-	-
B	CLUTCH +24V (BEFORE FREEZE SW)	-	-	-	-
C	MEDIUM PRESSURE SIGNAL	-	-	-	-
D	+24V	-	-	-	-
E	HI/LO PRESSURE SIGNAL	-	-	-	-
F	+24V	-	-	-	-
G	RA TEMP SENSOR RTN	-	-	-	-
H	RA TEMP SENSOR	-	-	-	-

B235005768

Figure 54. Connector Composites (P20, P21, P22, P23).

CONNECTOR COMPOSITES - (CONTINUED)

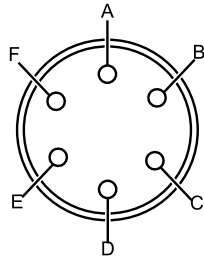

HVAC
(P29)

CAV	CIRCUIT	GAUGE	COLOR	TERMINAL	SEAL
A	3 WAY VALVE	-	-	-	-
B	SPARE	-	-	-	-
C	HIGH IDLE SPEED REQUEST	-	-	-	-
D	LOW PRESSURE SW GND	-	-	-	-
E	LOW PRESSURE SW SIGNAL RTN	-	-	-	-
F	3 WAY VALVE RETURN	-	-	-	-

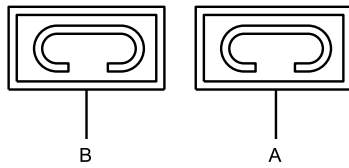

FREEZE SWITCH
(P31)

CAV	CIRCUIT	GAUGE	COLOR	TERMINAL	SEAL
A	CLUTCH +24V (AFTER FREEZE SW)	-	-	-	-
B	CLUTCH +24V (BEFORE FREEZE SW)	-	-	-	-

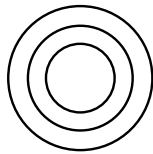

LOW PRESSURE SWITCH GROUND CIRCUIT
(HARNESS SIDE)
(P33)

CAV	CIRCUIT	GAUGE	COLOR	TERMINAL	SEAL
-	-	-	-	-	-

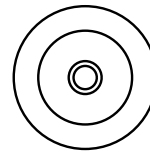

3-WAY VALVE INTERFACE
(P33)

CAV	CIRCUIT	GAUGE	COLOR	TERMINAL	SEAL
-	3 WAY VALVE +24V	-	-	-	-

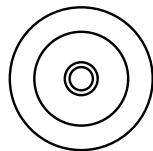

HVAC ENGINE HARNESS
3-WAY VALVE
(P33)

CAV	CIRCUIT	GAUGE	COLOR	TERMINAL	SEAL
-	3 WAY VALVE RTN	-	-	-	-

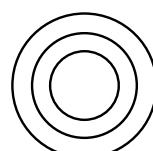

LEFT HVAC CONTROL 2
(P34)

CAV	CIRCUIT	GAUGE	COLOR	TERMINAL	SEAL
-	+24V	12	BK	-	-

B235005767

Figure 55. Connector Composites (P29, P31, P33, P33, P33, P34).

CONNECTOR COMPOSITES - (CONTINUED)

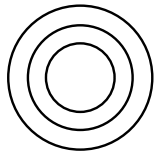

RIGHT HVAC CONTROL 2
(P34)

CAV	CIRCUIT	GAUGE	COLOR	TERMINAL	SEAL
-	+24V	12	BK	-	-

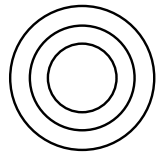

LEFT CONDENSER CONTROL
(P34)

CAV	CIRCUIT	GAUGE	COLOR	TERMINAL	SEAL
-	GND	12	BK	-	-

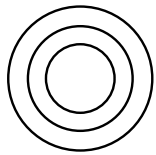

RIGHT CONDENSER CONTROL
(P34)

CAV	CIRCUIT	GAUGE	COLOR	TERMINAL	SEAL
-	GND	12	BK	-	-

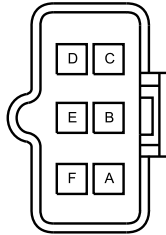

HVAC INTERCONNECT (CLEAR)
(P35)

CAV	CIRCUIT	GAUGE	COLOR	TERMINAL	SEAL
A	CONDENSER FAN ON	-	-	-	-
B	GND	-	-	-	-
C	+24V	-	-	-	-
D	+24V	-	-	-	-
E	GND	-	-	-	-
F	GND	-	-	-	-

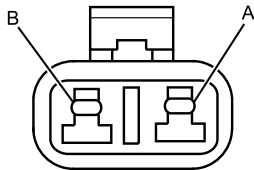

A/C COMPRESSOR
(P36)

CAV	CIRCUIT	GAUGE	COLOR	TERMINAL	SEAL
A	COMPRESSOR CLUTCH RTN	-	-	-	-
B	COMPRESSOR CLUTCH +24V	-	-	-	-

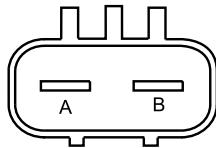

A/C SYSTEM HIGH IDLE
(P37)

CAV	CIRCUIT	GAUGE	COLOR	TERMINAL	SEAL
A	HIGH IDLE REQUEST	-	-	-	-
B	-	-	-	-	-

B235005769

Figure 56. Connector Composites (P34, P34, P34, P35, P36, P37).

CONNECTOR COMPOSITES - (CONTINUED)

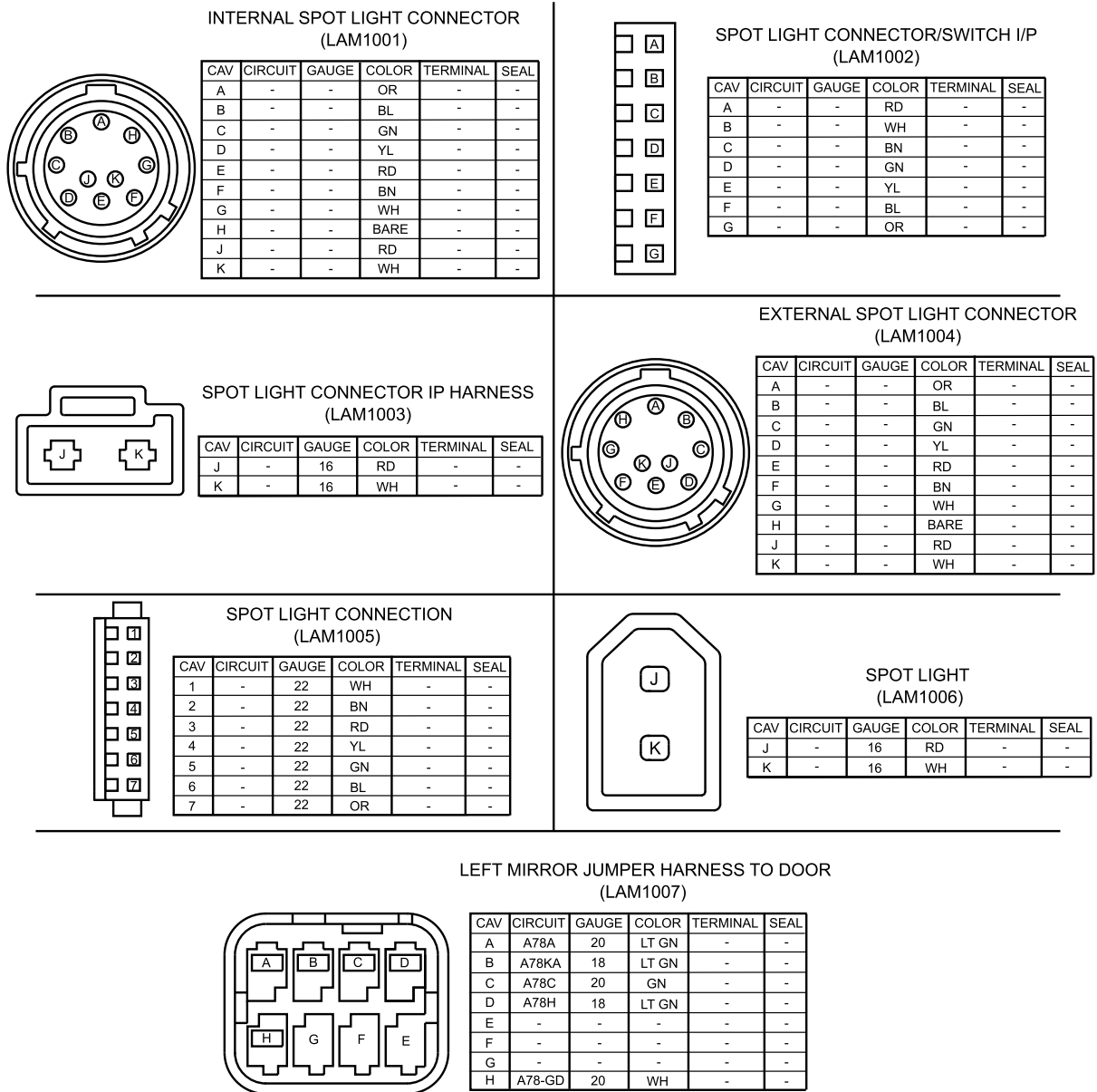

B235005744

Figure 57. Connector Composites (LAM1001, LAM1002, LAM1003, LAM1004, LAM1005, LAM1006, LAM1007).

CONNECTOR COMPOSITES - (CONTINUED)

**LEFT POWER MIRROR
(LAM1008)**

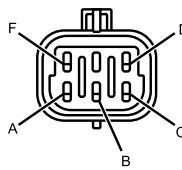

CAV	CIRCUIT	GAUGE	COLOR	TERMINAL	SEAL
A	A78A	20	LTGN	12045773	15324973
B	A78B	20	LTGN	12045773	15324973
C	A78C	20	LTGN	12045773	15324973
D	A78D	18	DKGN	12045773	15324973
E	-	-	-	-	-
F	A78-GD	20	WH	12045773	15324973

**LEFT MIRROR JUMPER HARNESS
THROUGH MIRROR
(LAM1009)**

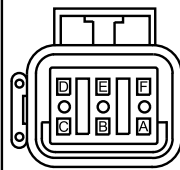

CAV	CIRCUIT	GAUGE	COLOR	TERMINAL	SEAL
A	A78A	18	RD	-	-
B	A78KA	20	GN	-	-
C	A78C	20	YL	-	-
D	A78-GD	18	BK	-	-
E	-	-	-	-	-
F	A78H	20	WH	-	-

**LEFT MIRROR JUMPER HARNESS IN MIRROR
(LAM1010)**

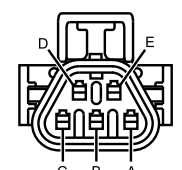

CAV	CIRCUIT	GAUGE	COLOR	TERMINAL	SEAL
A	A78-GD	18	WH	-	-
B	A78A	20	YL	-	-
C	A78KA	18	RD	-	-
D	A78H	18	BK	-	-
E	A78C	20	GN	-	-

**CAMSHAFT POSITION (CMP) SENSOR
(LAM1011)**

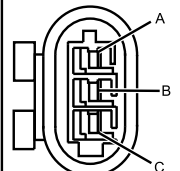

CAV	CIRCUIT	GAUGE	COLOR	TERMINAL	SEAL
A	97GA	18	VT	-	-
B	97CY4	18	VT	-	-
C	97BE	18	VT	-	-

**SPOT LIGHT MOTOR STATIC
DRAIN WIRE CONNECTOR IP
(LAM1012)**

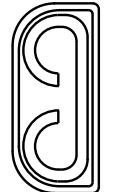

CAV	CIRCUIT	GAUGE	COLOR	TERMINAL	SEAL
H	-	-	BARE	-	-

**ENGINE OIL PRESSURE SENSOR
(LAM1013)**

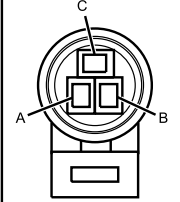

CAV	CIRCUIT	GAUGE	COLOR	TERMINAL	SEAL
A	97DC3	18	VT	-	-
B	97CY3	18	VT	-	-
C	97BK	18	VT	-	-

**MANIFOLD ABSOLUTE PRESSURE SENSOR
(LAM1014)**

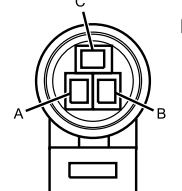

CAV	CIRCUIT	GAUGE	COLOR	TERMINAL	SEAL
A	97DC2	18	VT	-	-
B	97CY2	18	VT	-	-
C	97AY	18	VT	-	-

**ENGINE OIL TEMPERATURE
(LAM1015)**

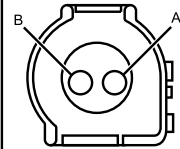

CAV	CIRCUIT	GAUGE	COLOR	TERMINAL	SEAL
A	97DC4	18	VT	-	-
B	97CE	18	VT	-	-

**INJECTOR PRESSURE REGULATOR
(LAM1016)**

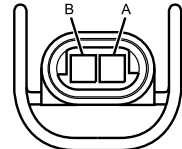

CAV	CIRCUIT	GAUGE	COLOR	TERMINAL	SEAL
A	97DA	18	VT	-	-
B	97BH	18	VT	-	-

B235005745

Figure 58. Connector Composites (LAM1008, LAM1009, LAM1010, LAM1011, LAM1012, LAM1013, LAM1014, LAM1015, LAM1016).

CONNECTOR COMPOSITES - (CONTINUED)

**INJECTOR CONTROL PRESSURE SENSOR
(LAM1018)**

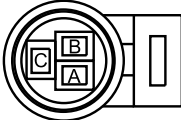

CAV	CIRCUIT	GAUGE	COLOR	TERMINAL	SEAL
A	97DC1	18	VT	-	-
B	97CY1	18	VT	-	-
C	97BG	18	VT	-	-

**FUEL INJECTOR HARNESS
(LAM1020)**

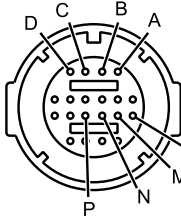

CAV	CIRCUIT	GAUGE	COLOR	TERMINAL	SEAL
A	97MY	18	VT	-	-
B	97AB	18	VT	-	-
C	97BR	18	VT	-	-
D	97BP	18	VT	-	-
L	97MM	18	VT	-	-
M	97AD	18	VT	-	-
N	97BN	18	VT	-	-
P	97AP	18	VT	-	-

**ENGINE CONTROL MODULE (ECM)
(LAM1019)**

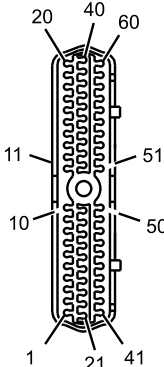

CAV	CIRCUIT	GAUGE	COLOR	TERMINAL	SEAL
12	97CE	18	VT	-	-
13	97BF	18	VT	-	-
14	97BK	18	VT	-	-
16	97BG	18	VT	-	-
17	97DA	18	VT	-	-
19	97DC	18	VT	-	-
21	97BR	18	VT	-	-
24	97DW	18	VT	-	-
25	97BN	18	VT	-	-
26	97MM	18	VT	-	-
30	97AY	18	VT	-	-
37	97BH	18	VT	-	-
40	97CY	18	VT	-	-
41	97BP	18	VT	-	-
42	97MY	18	VT	-	-
43	97AB	18	VT	-	-
44	97AP	18	VT	-	-
46	97AD	18	VT	-	-
51	97BE	18	VT	-	-
53	97GA	18	VT	-	-

**DOMELAMP CONNECTOR
(LAM1021)**

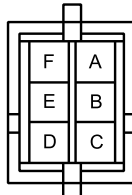

CAV	CIRCUIT	GAUGE	COLOR	TERMINAL	SEAL
A	A63VB	16	BK	12034047	-
B	A63-GA	16	WH	12034047	-
C	A63AB	16	RD	12034047	-
D	A63AA	16	GY	12034047	-
E	-	-	-	-	-
F	-	-	-	-	-

**FRONT CREW LIGHT
(LAM1022)**

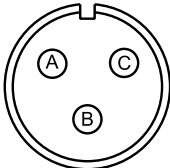

CAV	CIRCUIT	GAUGE	COLOR	TERMINAL	SEAL
A	+24V	16	BK	-	-
B	GND	16	WH	-	-
C	-	-	-	-	-

**RIGHT REAR CREW LIGHT
(LAM1023)**

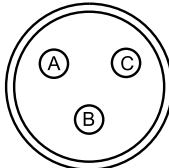

CAV	CIRCUIT	GAUGE	COLOR	TERMINAL	SEAL
A	+24V	16	RD	-	-
B	GND	16	WH	-	-
C	+24V	16	BL	-	-

**RIGHT REAR CREW LIGHT
(LAM1024)**

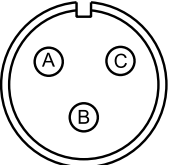

CAV	CIRCUIT	GAUGE	COLOR	TERMINAL	SEAL
A	+24V	16	BK	-	-
B	GND	16	RD	-	-
C	+24V	16	BL	-	-

**LEFT REAR CREW LIGHT
(LAM1025)**

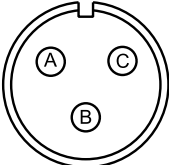

CAV	CIRCUIT	GAUGE	COLOR	TERMINAL	SEAL
A	+24V	16	BK	-	-
B	GND	16	RD	-	-
C	+24V	16	BL	-	-

B235005746

Figure 59. Connector Composites (LAM1018, LAM1019, LAM1020, LAM1021, LAM1022, LAM1023, LAM1024, LAM1025).

CONNECTOR COMPOSITES - (CONTINUED)

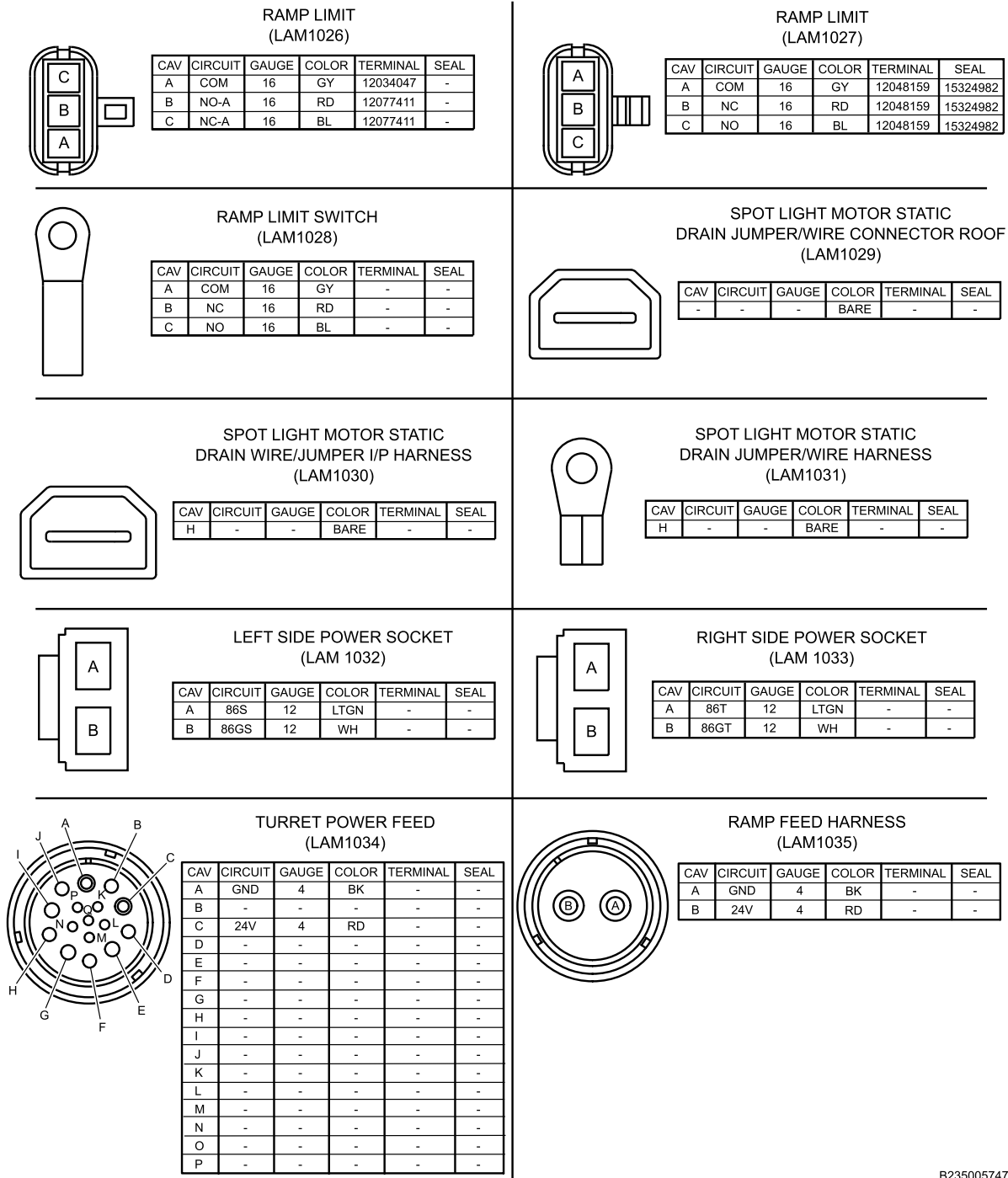

B235005747

Figure 60. Connector Composites (LAM1026, LAM1027, LAM1028, LAM1029, LAM1030, LAM1031, LAM1032, LAM1033, LAM1034, LAM1035).

CONNECTOR COMPOSITES - (CONTINUED)

**24V IP FEED HARNESS
(LAM1036)**

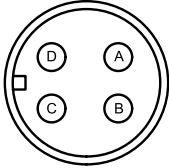

CAV	CIRCUIT	GAUGE	COLOR	TERMINAL	SEAL
A	-	-	-	-	-
B	+24V	8	RD	-	-
C	+24V	8	RD	-	-
D	-	-	-	-	-

**PDM CASE GROUND
(LAM1037)**

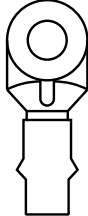

CAV	CIRCUIT	GAUGE	COLOR	TERMINAL	SEAL
A	GND	3	BK	-	-

**GFE FEED HARNESS
(LAM1038)**

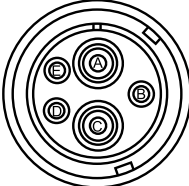

CAV	CIRCUIT	GAUGE	COLOR	TERMINAL	SEAL
A	+24V	4	RD	31133405C01	-
B	-	-	-	-	-
C	GND	4	BK	31133405C01	-
D	-	-	-	-	-
E	-	-	-	-	-

**CLEARANCE LIGHTS CABIN JUMPER HARNESS
(LAM1039)**

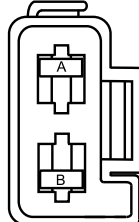

CAV	CIRCUIT	GAUGE	COLOR	TERMINAL	SEAL
A	PWR-1	20	BK	-	-
B	GRD-1	20	WH	-	-

**ENGINE COOLANT TEMPERATURE SENSOR
(LAM1040)**

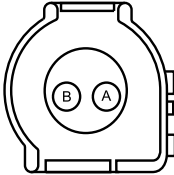

CAV	CIRCUIT	GAUGE	COLOR	TERMINAL	SEAL
A	97DC5	18	VT	-	-
B	97BF	18	VT	-	-

**24V INSTRUMENT PANEL FEED HARNESS
(LAM1041)**

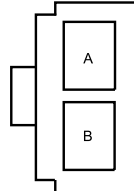

CAV	CIRCUIT	GAUGE	COLOR	TERMINAL	SEAL
A	PWR-3	10	RD	1661211C1	-
B	PWR-4	10	RD	1661211C1	-

**RIGHT MIRROR JUMPER HARNESS TO DOOR
(LAM1042)**

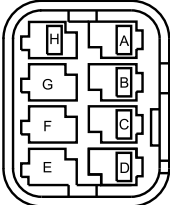

CAV	CIRCUIT	GAUGE	COLOR	TERMINAL	SEAL
A	A78A	20	LT GN	-	-
B	A78KA	18	LT GN	-	-
C	A78C	20	GN	-	-
D	A78H	18	LT GN	-	-
E	-	-	-	-	-
F	-	-	-	-	-
G	-	-	-	-	-
H	A78-GD	20	WH	-	-

**PDM FIREWALL GROUND
(LAM1043)**

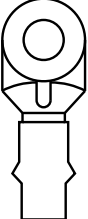

CAV	CIRCUIT	GAUGE	COLOR	TERMINAL	SEAL
A	GND	3	BK	-	-

**24V BODY FEED HARNESS CONNECTOR
(LAM1044)**

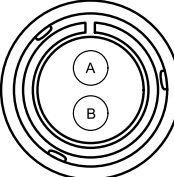

CAV	CIRCUIT	GAUGE	COLOR	TERMINAL	SEAL
A	37	1/0	RD	031-8521-000	-
B	37-1	1/0	RD	031-8621-000	-

**GROUND CABLE FIREWALL
(LAM1045)**



CAV	CIRCUIT	GAUGE	COLOR	TERMINAL	SEAL
A	-	-	BK	-	-

B235005748

Figure 61. Connector Composites (LAM1036, LAM1037, LAM1038, LAM1039, LAM1040, LAM1041, LAM1042, LAM1043, LAM1044, LAM1045).

CONNECTOR COMPOSITES - (CONTINUED)

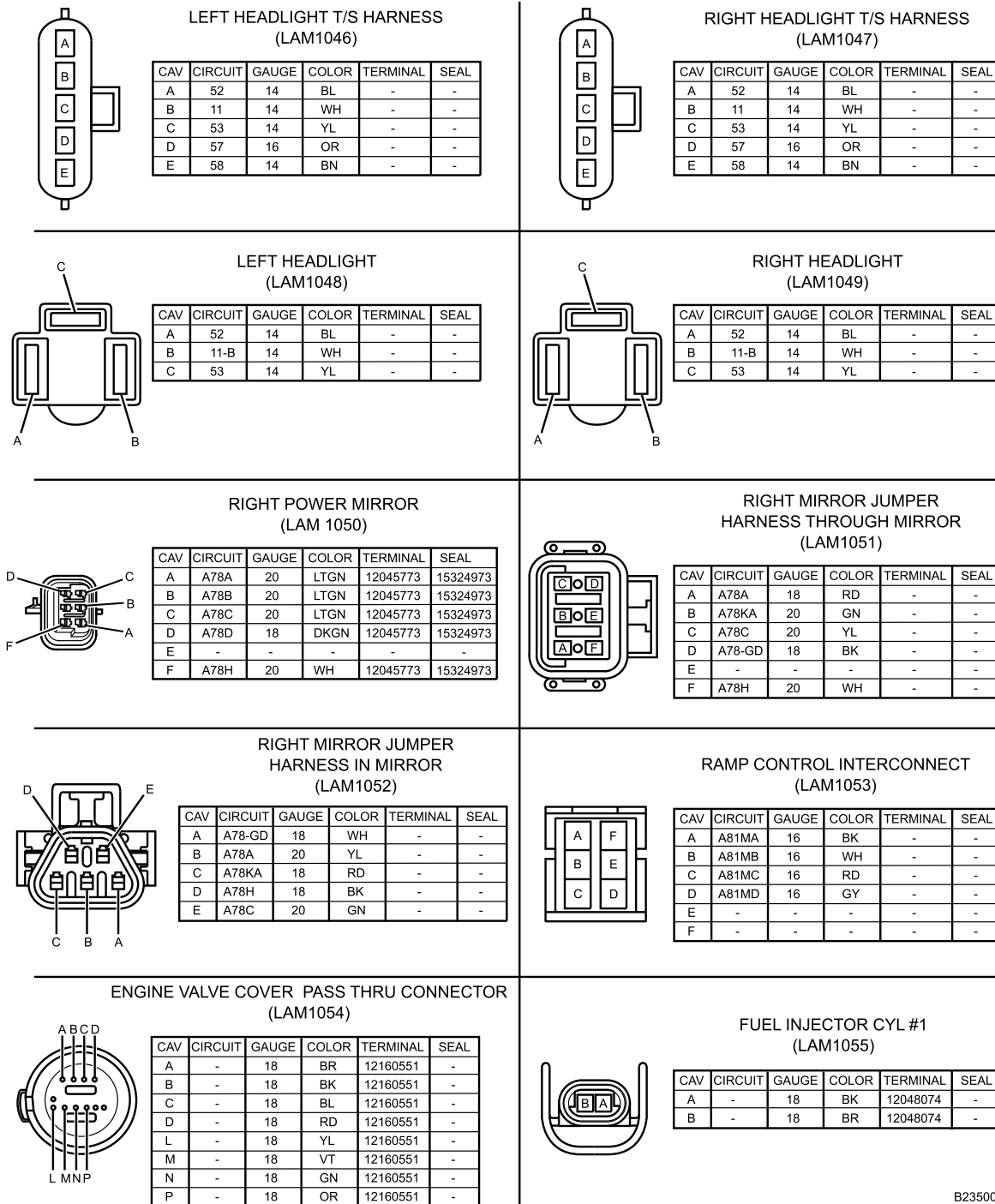

B235005749

Figure 62. Connector Composites (LAM1046, LAM1047, LAM1048, LAM1049, LAM1050, LAM1051, LAM1052, LAM1053, LAM1054, LAM1055).

CONNECTOR COMPOSITES - (CONTINUED)

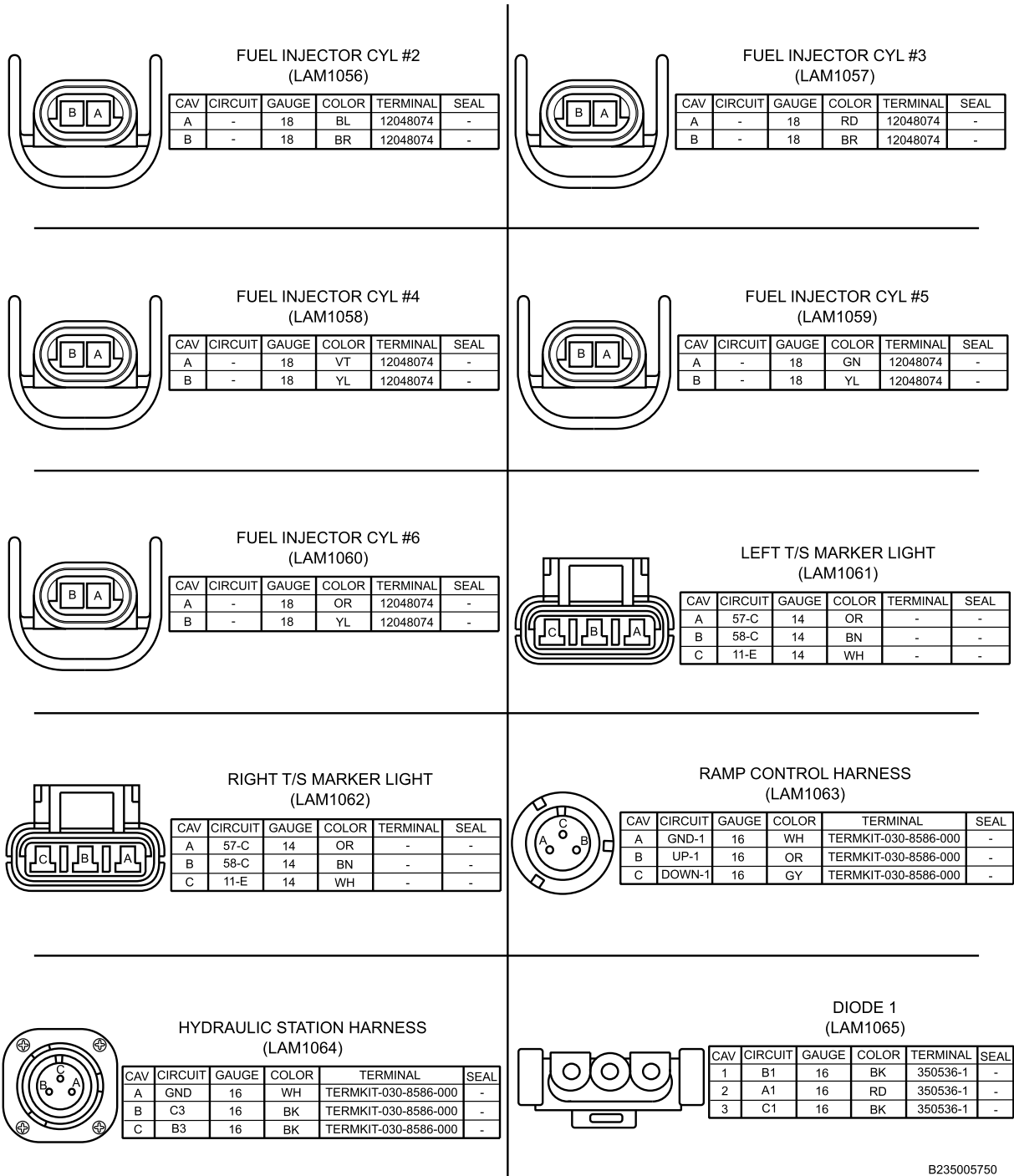

B235005750

Figure 63. Connector Composites (LAM1056, LAM1057, LAM1058, LAM1059, LAM1060, LAM1061, LAM1062, LAM1063, LAM1064, LAM1065).

CONNECTOR COMPOSITES - (CONTINUED)

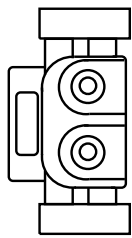

DIODE2
(LAM1066)

CAV	CIRCUIT	GAUGE	COLOR	TERMINAL	SEAL
1	A2	16	RD	350536-1	-
2	D1	16	BK	350536-1	-

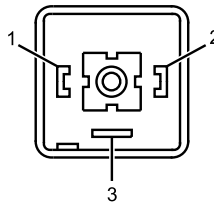

HYDRAULIC SOLENOID VALVE
(LAM1068)

CAV	CIRCUIT	GAUGE	COLOR	TERMINAL	SEAL
1	AD	16	RD	-	-
2	BD	16	BK	-	-
3	-	-	-	-	-

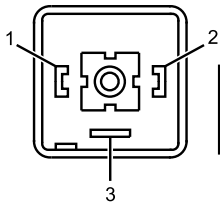

HYDRAULIC SOLENOID VALVE
(LAM1069)

CAV	CIRCUIT	GAUGE	COLOR	TERMINAL	SEAL
1	AU	16	RD	-	-
2	CU	16	BK	-	-
3	-	-	-	-	-

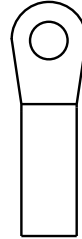

CREW RAMP SWITCH
(LAM1070)

CAV	CIRCUIT	GAUGE	COLOR	TERMINAL	SEAL
1	GND-2	16	WH	-	-
2	JMP	16	WH	-	-
3	DOWN-2	16	GY	-	-
4	UP-2	16	OR	-	-
5	GND-1	16	WH	-	-
6	JMP	16	WH	-	-

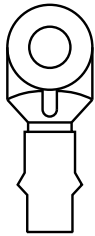

RAMP FEED HARNESS
(LAM1071)

CAV	CIRCUIT	GAUGE	COLOR	TERMINAL	SEAL
-	24V	4	RD	-	-

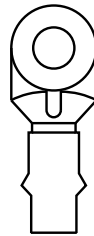

RAMP FEED HARNESS
(LAM1072)

CAV	CIRCUIT	GAUGE	COLOR	TERMINAL	SEAL
-	GND	4	BK	-	-

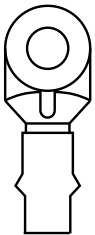

INVERTER 24V POSITIVE FEED
(LAM1073)

CAV	CIRCUIT	GAUGE	COLOR	TERMINAL	SEAL
-	-	-	RD	-	-



INVERTER GROUND
(LAM1074)

CAV	CIRCUIT	GAUGE	COLOR	TERMINAL	SEAL
-	-	-	BK	-	-

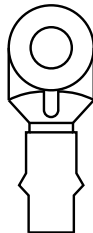

SOLENOID 24V POSITIVE FEED
(LAM1075)

CAV	CIRCUIT	GAUGE	COLOR	TERMINAL	SEAL
-	-	-	RD	-	-

B235005751

Figure 64. Connector Composites (LAM1066, LAM1068, LAM1069, LAM1070, LAM1071, LAM1072, LAM1073, LAM1074, LAM1075).

CONNECTOR COMPOSITES - (CONTINUED)

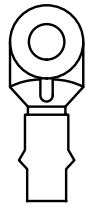

SOLENOID 24V DELIVERY
(LAM1076)

CAV	CIRCUIT	GAUGE	COLOR	TERMINAL	SLEEVE
A	-	-	RD	-	-

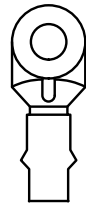

INVERTER 150AMP FUSE 24V
(LAM1077)

CAV	CIRCUIT	GAUGE	COLOR	TERMINAL	SLEEVE
A	-	-	RD	-	-

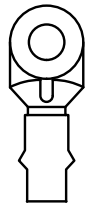

INVERTER 150AMP FUSE 24V FEED
(LAM1078)

CAV	CIRCUIT	GAUGE	COLOR	TERMINAL	SLEEVE
A	-	-	RD	-	-

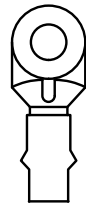

SOLENOID 12V POSITIVE CONTROL
(LAM1079)

CAV	CIRCUIT	GAUGE	COLOR	TERMINAL	SLEEVE
A	-	-	RD	-	-



SOLENOID GROUND CONTROL
(LAM1080)

CAV	CIRCUIT	GAUGE	COLOR	TERMINAL	SLEEVE
A	-	-	WH	-	-



NATO SLAVE TO 150AMP FUSE 24V SUPPLY
(LAM1081)

CAV	CIRCUIT	GAUGE	COLOR	TERMINAL	SLEEVE
A	-	-	RD	-	-

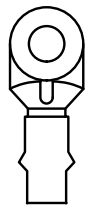

INVERTER GROUND SUPPLY
(LAM1082)

CAV	CIRCUIT	GAUGE	COLOR	TERMINAL	SLEEVE
A	-	-	BK	-	-

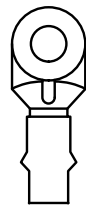

NATO SLAVE 24V POSITIVE FEED
(LAM1083)

CAV	CIRCUIT	GAUGE	COLOR	TERMINAL	SLEEVE
A	-	-	RD	-	-

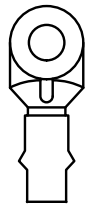

NATO SLAVE GROUND
(LAM1084)

CAV	CIRCUIT	GAUGE	COLOR	TERMINAL	SLEEVE
A	-	-	BK	-	-

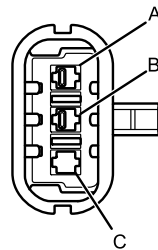

TAILLAMP HARNESS 3-PIN
(LAM1085)

CAV	CIRCUIT	GAUGE	COLOR	TERMINAL	SEAL
A	23J	14	OR	-	-
B	24J	14	OR	-	-
C	-	-	-	-	-

B235005752

Figure 65. Connector Composites (LAM1076, LAM1077, LAM1078, LAM1079, LAM1080, LAM1081, LAM1082, LAM1083, LAM1084, LAM1085).

CONNECTOR COMPOSITES - (CONTINUED)

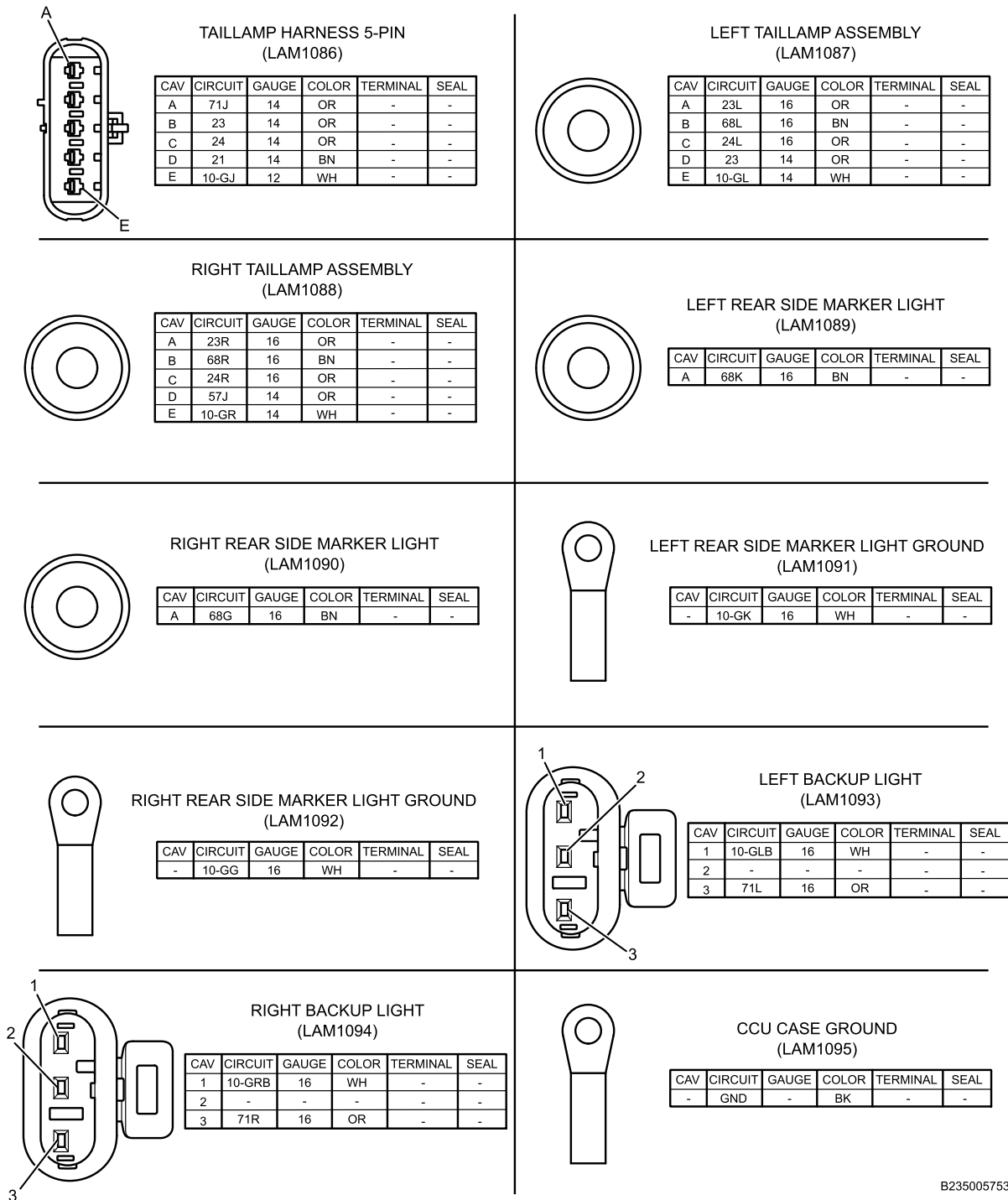

B235005753

Figure 66. Connector Composites (LAM1086, LAM1087, LAM1088, LAM1089, LAM1090, LAM1091, LAM1092, LAM1093, LAM1094, LAM1095).

CONNECTOR COMPOSITES - (CONTINUED)

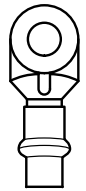

24V BODY FEED HARNESS
(LAM1096)

CAV	CIRCUIT	GAUGE	COLOR	TERMINAL	SEAL
A	37	1/0	RD	1526596-2	-

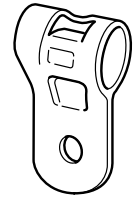

24V BODY FEED CONNECTOR
(LAM1097)

CAV	CIRCUIT	GAUGE	COLOR	TERMINAL	SEAL
A	37-1	1/0	RD	351580	-

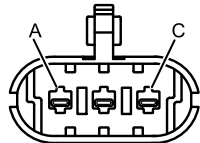

FRONT BUMPER LEFT HARNESS 3-PIN
(LAM1098)

CAV	CIRCUIT	GAUGE	COLOR	TERMINAL	SEAL
A	483	16	GN	-	-
B	B/O-D	16	YL	-	-
C	IR	16	RD	-	-

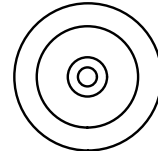

FRONT BUMPER LEFT HARNESS
BLACKOUT DRIVING LIGHT
(LAM1099)

CAV	CIRCUIT	GAUGE	COLOR	TERMINAL	SEAL
1	B/O-D	16	YL	-	-

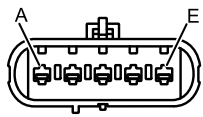

FRONT BUMPER LEFT HARNESS 5-PIN
(LAM1100)

CAV	CIRCUIT	GAUGE	COLOR	TERMINAL	SEAL
A	52	16	YL	-	-
B	11	16	WH	-	-
C	53	16	YL	-	-
D	57	16	OR	-	-
E	58	16	BN	-	-

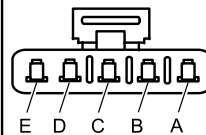

FORWARD CHASSIS HARNESS 5-PIN
TO LEFT FRONT BUMPER HARNESS
(LAM1101)

CAV	CIRCUIT	GAUGE	COLOR	TERMINAL	SEAL
A	52	16	YL	-	-
B	11	16	WH	-	-
C	53	16	YL	-	-
D	57	16	OR	-	-
E	58	16	BN	-	-

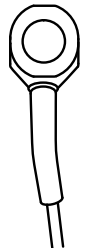

FRONT BUMPER LEFT HARNESS
GROUND EYELET
(LAM1102)

CAV	CIRCUIT	GAUGE	COLOR	TERMINAL	SEAL
-	11-C	16	WH	-	-

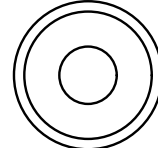

FRONT BUMPER LEFT HARNESS
LIGHT ASSEMBLY
(LAM1103)

CAV	CIRCUIT	GAUGE	COLOR	TERMINAL	SEAL
1	483	16	GN	-	-

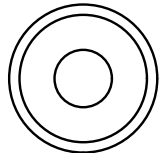

FRONT BUMPER RIGHT HARNESS
LIGHT ASSEMBLY
(LAM1104)

CAV	CIRCUIT	GAUGE	COLOR	TERMINAL	SEAL
A	483	14	GN	-	-

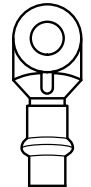

WINCH MEGAFUSE FEED CABLE
(LAM1105)

CAV	CIRCUIT	GAUGE	COLOR	TERMINAL	SEAL
-	-	-	RD	-	-

B235005754

Figure 67. Connector Composites (LAM1096, LAM1097, LAM1098, LAM1099, LAM1100, LAM1101, LAM1102, LAM1103, LAM1104, LAM1105).

CONNECTOR COMPOSITES - (CONTINUED)

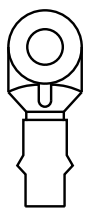

WINCH MEGAFUSE FEED CABLE
(LAM1106)

CAV	CIRCUIT	GAUGE	COLOR	TERMINAL	SEAL
-	-	-	RD	-	-

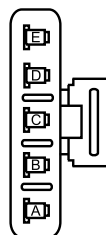

FORWARD CHASSIS HARNESS 5-PIN
TO RIGHT FRONT BUMPER HARNESS
(LAM1107)

CAV	CIRCUIT	GAUGE	COLOR	TERMINAL	SEAL
A	52	16	YL	-	-
B	11	16	WH	-	-
C	53	16	YL	-	-
D	57	16	OR	-	-
E	58	16	BN	-	-

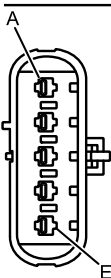

FRONT BUMPER RIGHT HARNESS 5-PIN
(LAM1108)

CAV	CIRCUIT	GAUGE	COLOR	TERMINAL	SEAL
A	52	14	YL	-	-
B	11	-	WH	-	-
C	53	-	YL	-	-
D	57	-	OR	-	-
E	58	-	BN	-	-



FRONT BUMPER RIGHT HARNESS 1-PIN
(LAM1109)

CAV	CIRCUIT	GAUGE	COLOR	TERMINAL	SEAL
A	483	14	GN	-	-

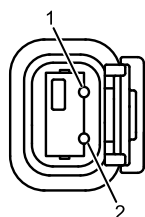

FRONT BUMPER LEFT HARNESS 2-PIN
(LAM1110)

CAV	CIRCUIT	GAUGE	COLOR	TERMINAL	SEAL
1	IR	16	RD	-	-
2	11-D	16	WH	-	-



MASTER VEHICLE LIGHT SWITCH GROUND
(LAM1111)

CAV	CIRCUIT	GAUGE	COLOR	TERMINAL	SEAL
-	-	-	GN	-	-

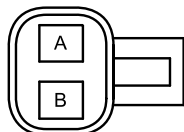

MASTER VEHICLE LIGHT SWITCH
GROUND JUMPER
(LAM1112)

CAV	CIRCUIT	GAUGE	COLOR	TERMINAL	SEAL
A	PLUG	-	-	-	-
B	-	-	BK	-	-



GROUND CABLE WHEEL DEFLECTOR
(LAM1113)

CAV	CIRCUIT	GAUGE	COLOR	TERMINAL	SEAL
-	-	-	BK	-	-



BATTERY 3 PARALLEL JUMPER
(LAM1114)

CAV	CIRCUIT	GAUGE	COLOR	TERMINAL	SEAL
-	-	-	RD	-	-



BATTERY 4 POSITIVE PARALLEL JUMPER
(LAM1115)

CAV	CIRCUIT	GAUGE	COLOR	TERMINAL	SEAL
-	-	-	RD	-	-

B235005755

Figure 68. Connector Composites (LAM1106, LAM1107, LAM1108, LAM1109, LAM1110, LAM1111, LAM1112, LAM1113, LAM1114, LAM1115).

CONNECTOR COMPOSITES - (CONTINUED)

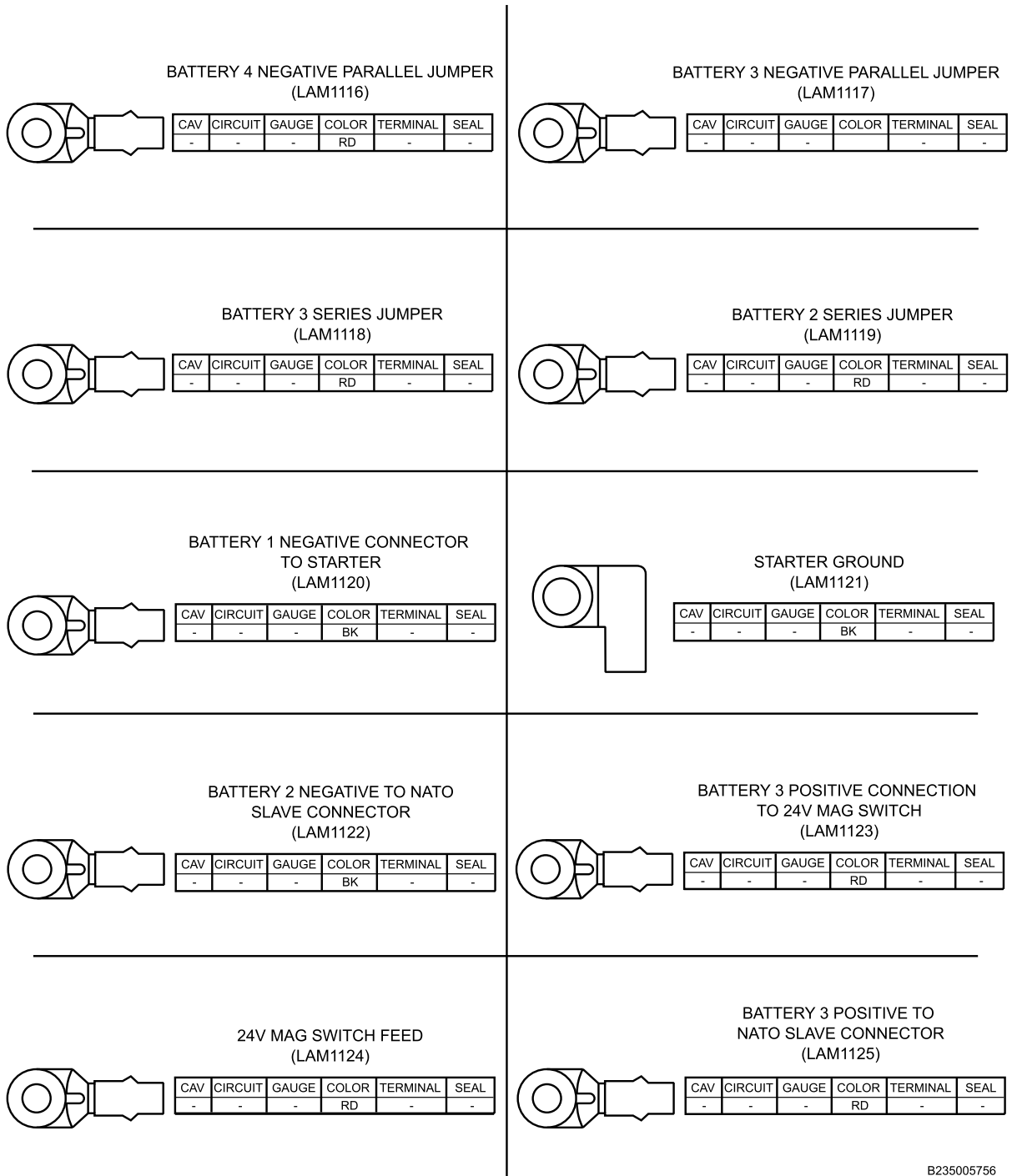

B235005756

Figure 69. Connector Composites (LAM1116, LAM1117, LAM1118, LAM1119, LAM1120, LAM1121, LAM1122, LAM1123, LAM1124, LAM1125).

CONNECTOR COMPOSITES - (CONTINUED)

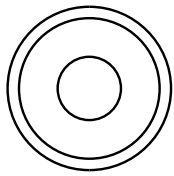

LEFT REAR CLEARANCE LIGHT POWER
(LAM1126)

CAV	CIRCUIT	GAUGE	COLOR	TERMINAL	SEAL
1	1-D	16	RD	-	-

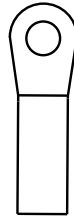

LEFT REAR CLEARANCE LIGHT GROUND
(LAM1127)

CAV	CIRCUIT	GAUGE	COLOR	TERMINAL	SEAL
1	2-D	16	WH	-	-

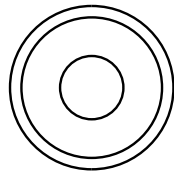

LEFT CENTER REAR CLEARANCE
LIGHT POWER
(LAM1128)

CAV	CIRCUIT	GAUGE	COLOR	TERMINAL	SEAL
1	1-C	16	RD	-	-



LEFT CENTER CLEARANCE LIGHT GROUND
(LAM1129)

CAV	CIRCUIT	GAUGE	COLOR	TERMINAL	SEAL
1	2-C	16	WH	-	-

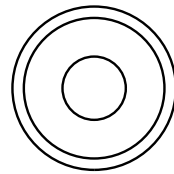

CENTER REAR CLEARANCE
LIGHT POWER
(LAM1130)

CAV	CIRCUIT	GAUGE	COLOR	TERMINAL	SEAL
1	1-B	16	RD	-	-



CENTER REAR CLEARANCE
LIGHT GROUND
(LAM1131)

CAV	CIRCUIT	GAUGE	COLOR	TERMINAL	SEAL
1	2-B	16	WH	-	-

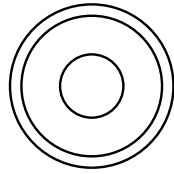

RIGHT CENTER REAR CLEARANCE
LIGHT POWER
(LAM1132)

CAV	CIRCUIT	GAUGE	COLOR	TERMINAL	SEAL
1	1-A	16	RD	-	-

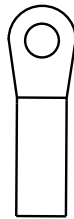

RIGHT CENTER REAR CLEARANCE
LIGHT GROUND
(LAM1133)

CAV	CIRCUIT	GAUGE	COLOR	TERMINAL	SEAL
1	2-A	16	WH	-	-

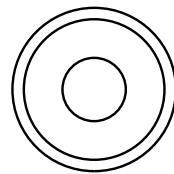

RIGHT REAR CLEARANCE
LIGHT POWER
(LAM1134)

CAV	CIRCUIT	GAUGE	COLOR	TERMINAL	SEAL
1	1	16	RD	-	-

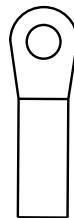

RIGHT REAR CLEARANCE
LIGHT GROUND
(LAM1135)

CAV	CIRCUIT	GAUGE	COLOR	TERMINAL	SEAL
1	2	16	WH	-	-

B235005757

Figure 70. Connector Composites (LAM1126, LAM1127, LAM1128, LAM1129, LAM1130, LAM1131, LAM1132, LAM1133, LAM1134, LAM1135).

CONNECTOR COMPOSITES - (CONTINUED)

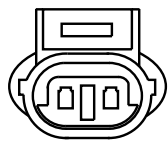

REAR CLEARANCE LIGHTS - LAMPS SIDE
(LAM1136)

CAV	CIRCUIT	GAUGE	COLOR	TERMINAL	SEAL
A	1-E	16	BK	-	-
B	2-E	16	WH	-	-

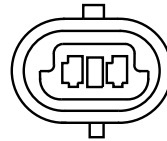

REAR CLEARANCE LIGHTS - HARNESS SIDE
(LAM1137)

CAV	CIRCUIT	GAUGE	COLOR	TERMINAL	SEAL
A	PWR-3	20	BK	-	-
B	GND-3	20	WH	-	-

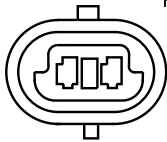

FRONT CLEARANCE LIGHTS - HARNESS SIDE
(LAM1138)

CAV	CIRCUIT	GAUGE	COLOR	TERMINAL	SEAL
A	PWR-1	20	BK	-	-
B	GND-1	20	WH	-	-

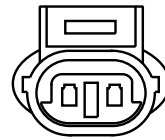

FRONT CLEARANCE LIGHTS - LAMPS SIDE
(LAM1139)

CAV	CIRCUIT	GAUGE	COLOR	TERMINAL	SEAL
A	1-E	16	BK	-	-
B	2-E	16	WH	-	-

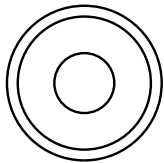

LEFT FRONT CLEARANCE LIGHT POWER
(LAM1140)

CAV	CIRCUIT	GAUGE	COLOR	TERMINAL	SEAL
1	1	16	RD	-	-

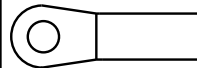

LEFT FRONT CLEARANCE LIGHT GROUND
(LAM1141)

CAV	CIRCUIT	GAUGE	COLOR	TERMINAL	SEAL
1	2	16	WH	-	-

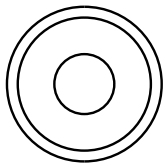

LEFT CENTER FRONT CLEARANCE
LIGHT POWER
(LAM1142)

CAV	CIRCUIT	GAUGE	COLOR	TERMINAL	SEAL
1	1-A	16	RD	-	-

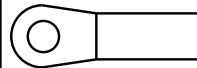

LEFT CENTER FRONT CLEARANCE
LIGHT GROUND
(LAM1143)

CAV	CIRCUIT	GAUGE	COLOR	TERMINAL	SEAL
1	2-A	16	WH	-	-

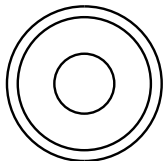

CENTER FRONT CLEARANCE LIGHT POWER
(LAM1144)

CAV	CIRCUIT	GAUGE	COLOR	TERMINAL	SEAL
1	1-B	16	RD	-	-

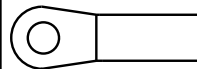

CENTER FRONT CLEARANCE
LIGHT GROUND
(LAM1145)

CAV	CIRCUIT	GAUGE	COLOR	TERMINAL	SEAL
1	2-B	16	WH	-	-

B235005758

Figure 71. Connector Composites (LAM1136, LAM1137, LAM1138, LAM1139, LAM1140, LAM1141, LAM1142, LAM1143, LAM1144, LAM1145).

CONNECTOR COMPOSITES - (CONTINUED)

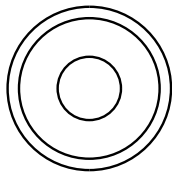

RIGHT CENTER FRONT CLEARANCE
LIGHT POWER
(LAM1146)

CAV	CIRCUIT	GAUGE	COLOR	TERMINAL	SEAL
1	1-C	16	RD	-	-



RIGHT CENTER FRONT CLEARANCE
LIGHT GROUND
(LAM1147)

CAV	CIRCUIT	GAUGE	COLOR	TERMINAL	SEAL
1	2-C	16	WH	-	-

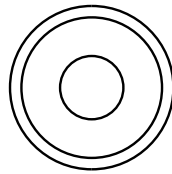

REAR FRONT CLEARANCE
LIGHT POWER
(LAM1148)

CAV	CIRCUIT	GAUGE	COLOR	TERMINAL	SEAL
1	1-D	16	RD	-	-



RIGHT FRONT CLEARANCE LIGHT GROUND
(LAM1149)

CAV	CIRCUIT	GAUGE	COLOR	TERMINAL	SEAL
1	2-D	16	WH	-	-

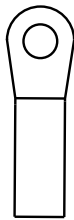

12V DISCONNECT
SWITCH GROUND
(LAM1150)

CAV	CIRCUIT	GAUGE	COLOR	TERMINAL	SEAL
A	N14-GB	-	WH	0365678C2	-



24V DISCONNECT SWITCH GROUND
(LAM1151)

CAV	CIRCUIT	GAUGE	COLOR	TERMINAL	SEAL
A	N14-GB	-	WH	0365678C2	-

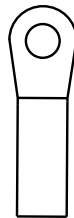

12V DISCONNECT SWITCH POWER
(LAM1152)

CAV	CIRCUIT	GAUGE	COLOR	TERMINAL	SEAL
A	N14/N14-A	-	RD	0365678C2	-



24V DISCONNECT SWITCH POWER
(LAM1153)

CAV	CIRCUIT	GAUGE	COLOR	TERMINAL	SEAL
A	N14	-	RD	0365678C2	-



12V DISCONNECT POWER FEED
(LAM1154)

CAV	CIRCUIT	GAUGE	COLOR	TERMINAL	SEAL
A	N14A	-	RD	3581768C1	-



LEFT SIDE POWER SOCKET 2
(LAM1155)

CAV	CIRCUIT	GAUGE	COLOR	TERMINAL	SEAL
B	86GS	12	WH	-	-

B235005759

Figure 72. Connector Composites (LAM1146, LAM1147, LAM1148, LAM1149, LAM1150, LAM1151, LAM1152, LAM1153, LAM1154, LAM1155).

CONNECTOR COMPOSITES - (CONTINUED)

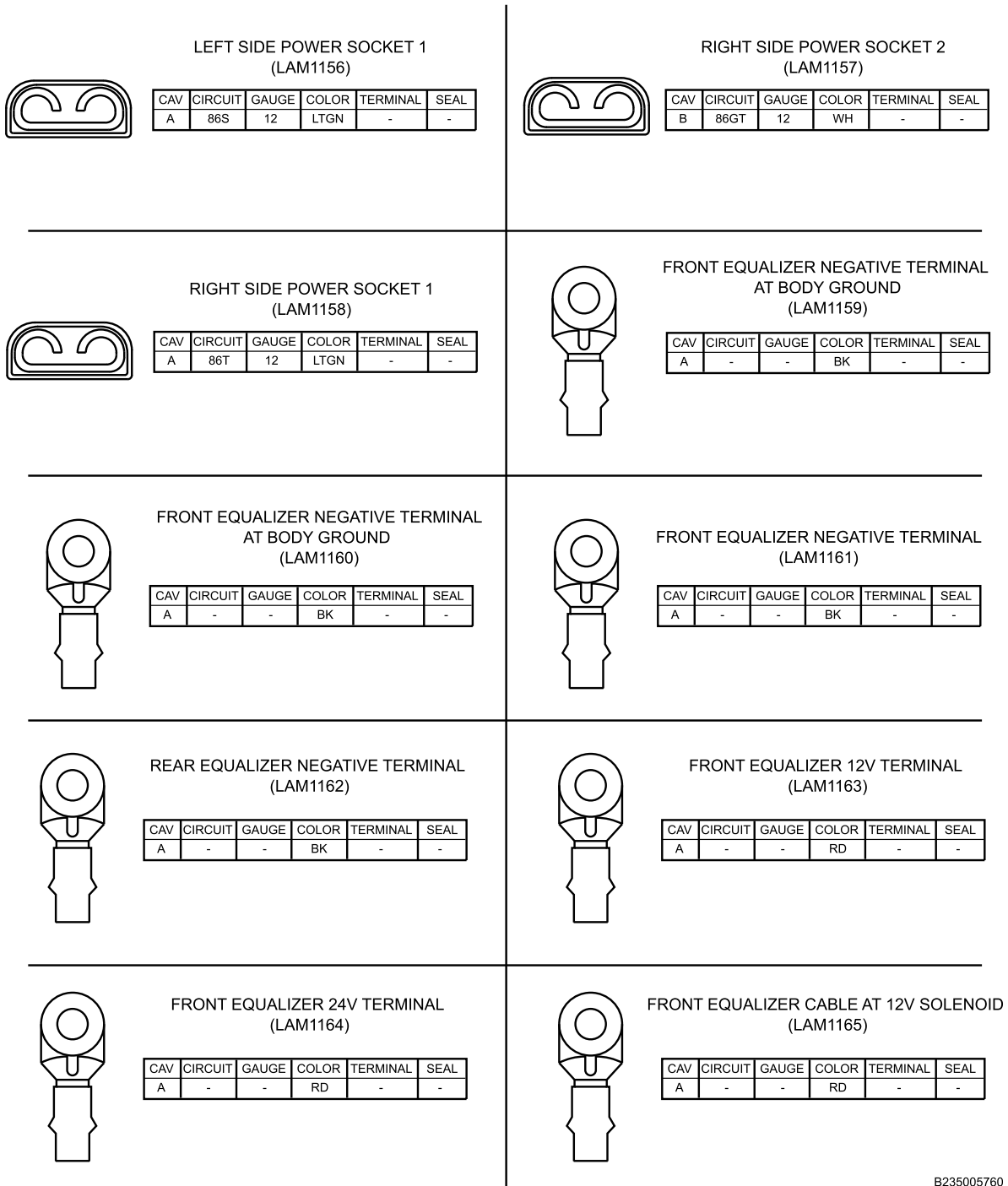

B235005760

Figure 73. Connector Composites (LAM1156, LAM1157, LAM1158, LAM1159, LAM1160, LAM1161, LAM1162, LAM1163, LAM1164, LAM1165).

CONNECTOR COMPOSITES - (CONTINUED)

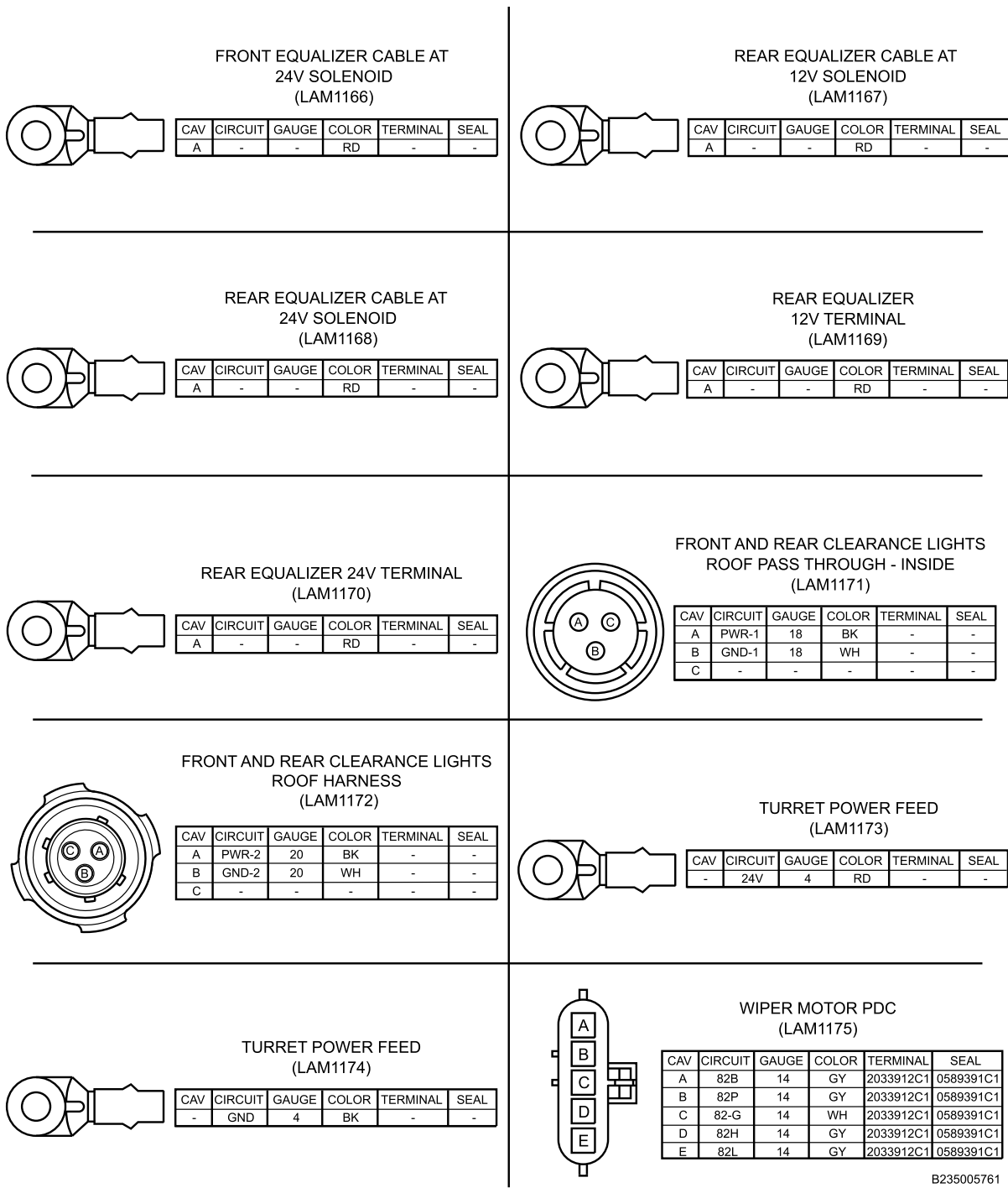

B235005761

Figure 74. Connector Composites (LAM1166, LAM1167, LAM1168, LAM1169, LAM1170, LAM1171, LAM1172, LAM1173, LAM1174, LAM1175).

CONNECTOR COMPOSITES - (CONTINUED)

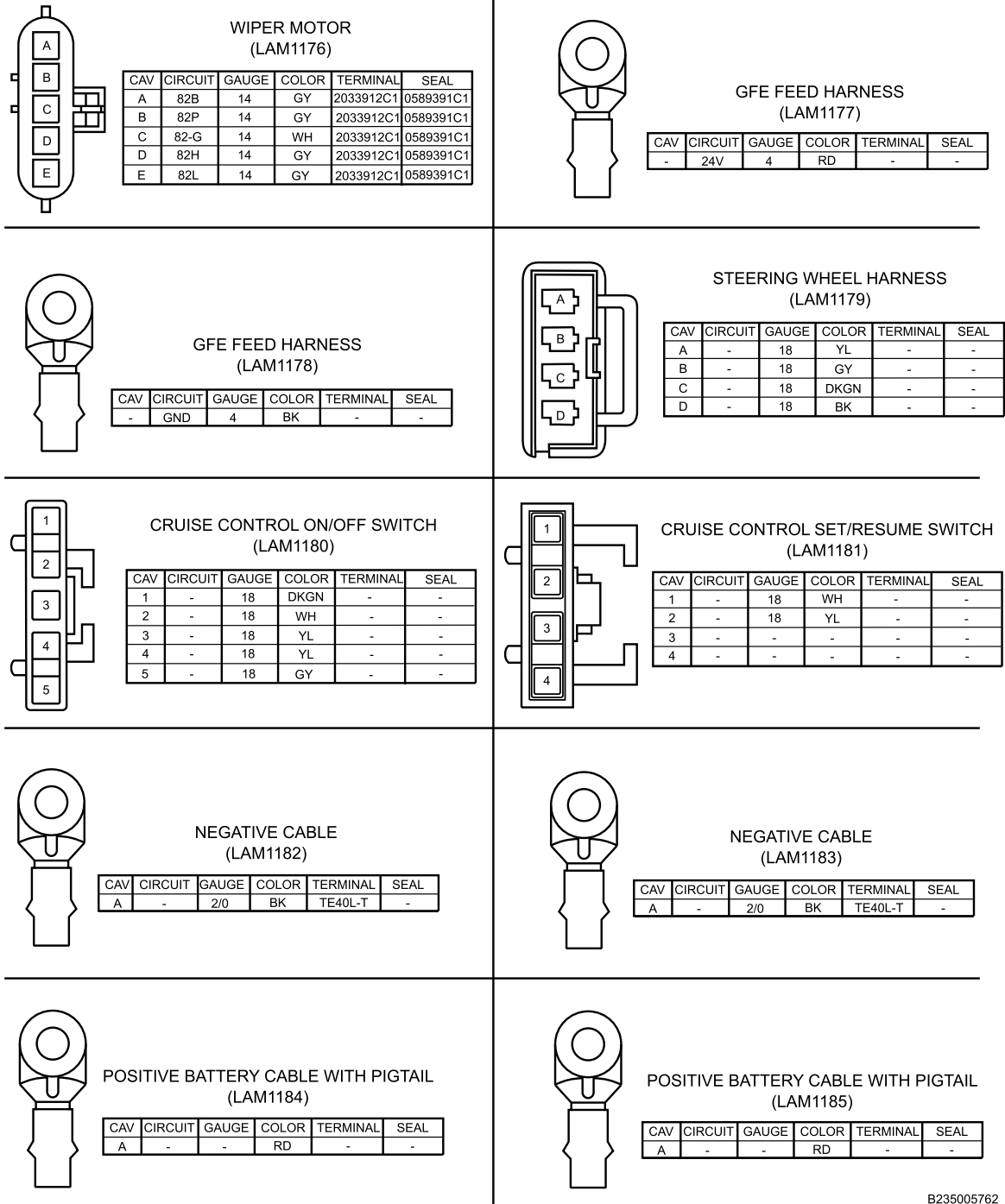

B235005762

Figure 75. Connector Composites (LAM1176, LAM1177, LAM1178, LAM1179, LAM1180, LAM1181, LAM1182, LAM1183, LAM1184, LAM1185).

CONNECTOR COMPOSITES - (CONTINUED)

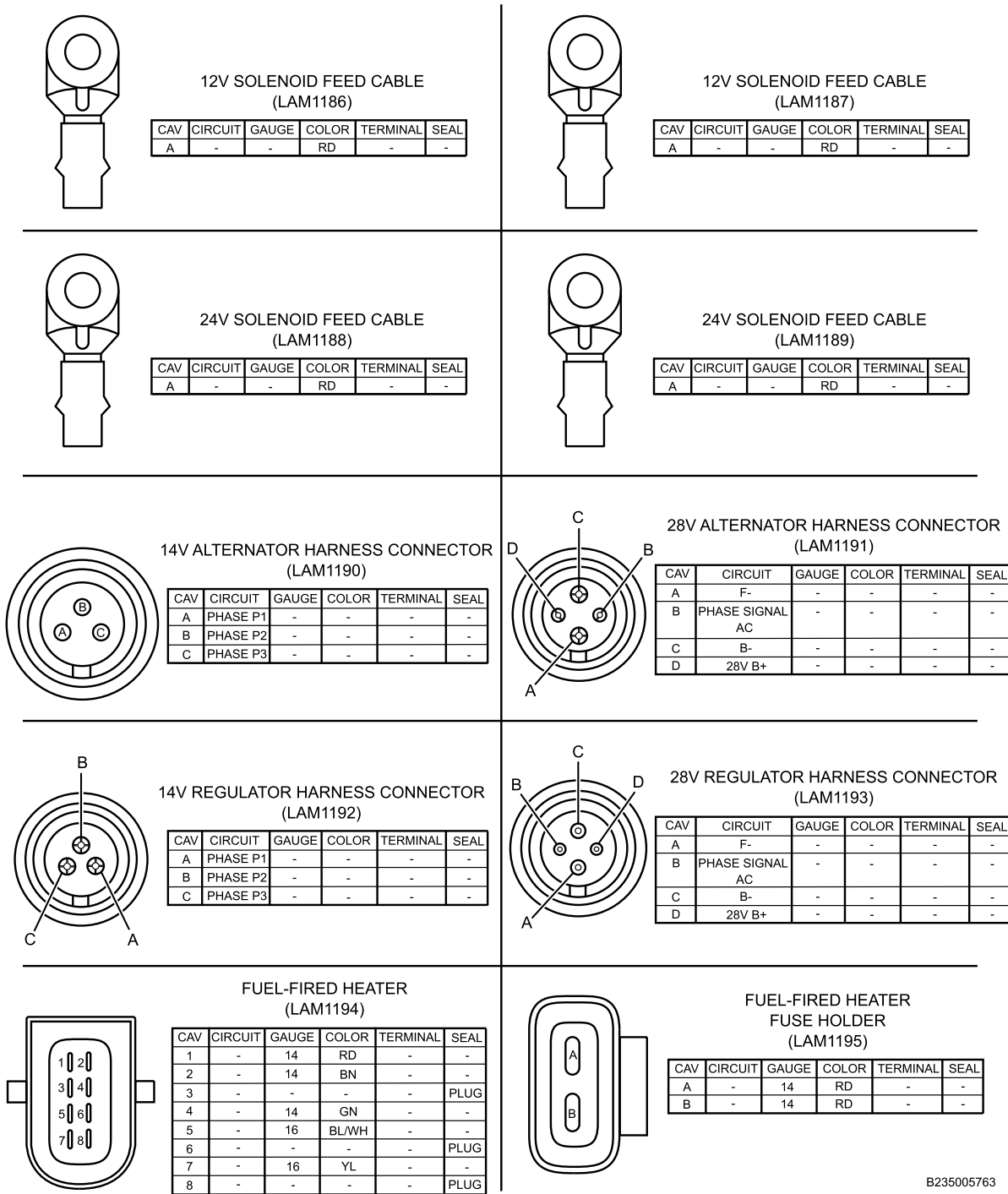

B235005763

Figure 76. Connector Composites (LAM1186, LAM1187, LAM1188, LAM1189, LAM1190, LAM1191, LAM1192, LAM1193, LAM1194, LAM1195).

CONNECTOR COMPOSITES - (CONTINUED)

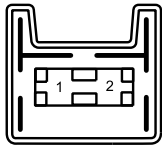

FUEL-FIRED HEATER FUEL PUMP
(LAM1196)

CAV	CIRCUIT	GAUGE	COLOR	TERMINAL	SEAL
1	-	16	GN	-	-
2	-	16	GN	-	-

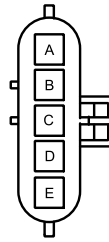

FUEL-FIRED HEATER HARNESS
(LAM1197)

CAV	CIRCUIT	GAUGE	COLOR	TERMINAL	SEAL
A	-	16	RD/YL	2033912C1	0589391C1
B	-	16	YL	2033912C1	0589391C1
C	-	16	BN	2033912C1	0589391C1
D	-	16	DK BL/WH	2033912C1	0589391C1
E	-	-	-	-	PLUG

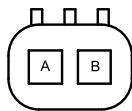

FUEL-FIRED HEATER POWER
AND GROUND HARNESS
(LAM1198)

CAV	CIRCUIT	GAUGE	COLOR	TERMINAL	SEAL
A	POWER	12	RD	-	-
B	GROUND	12	BN	-	-

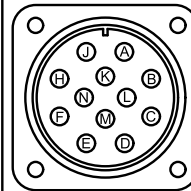

FRONT TRAILER HOOKUP HARNESS
TRAILER SOCKET
(LAM1199)

CAV	CIRCUIT	GAUGE	COLOR	TERMINAL	SEAL
A	94-A	14	GY	-	-
B	56	14	YL	-	-
C	94-B	14	GY	-	-
D	10-B	14	WH	-	-
E	58	14	BN	-	-
F	68	14	BN	-	-
H	94-C	14	GY	-	-
J	57	14	GY	-	-
K	72	14	GN	-	-
L	10-A	14	WH	-	-
M	70-A	14	RD	-	-
N	70-B	14	RD	-	-

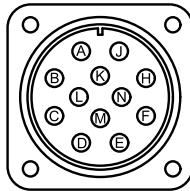

REAR TRAILER HOOKUP HARNESS
TRAILER SOCKET
(LAM1200)

CAV	CIRCUIT	GAUGE	COLOR	TERMINAL	SEAL
A	94-A	14	GY	-	-
B	56	14	YL	-	-
C	94-B	14	GY	-	-
D	10-B	14	WH	-	-
E	58	14	BN	-	-
F	68	14	BN	-	-
H	94-C	14	GY	-	-
J	57	14	GY	-	-
K	72	14	GN	-	-
L	10-A	14	WH	-	-
M	70-A	14	RD	-	-
N	70-B	14	RD	-	-



MASTER REAR DOOR / RAMP SWITCH
(LAM1201)

CAV	CIRCUIT	GAUGE	COLOR	TERMINAL	SEAL
A	-	-	RD	-	-
B	-	-	OR	-	-
C	-	-	YL	-	-
D	-	-	GN	-	-
E	-	-	BL	-	-
F	-	-	PL	-	-

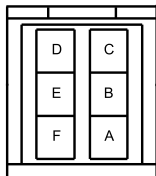

RAMP CONTROL SWITCH
(LAM1202)

CAV	CIRCUIT	GAUGE	COLOR	TERMINAL	SEAL
A	-	-	RD	-	-
B	-	-	OR	-	-
C	-	-	YL	-	-
D	-	-	GN	-	-
E	-	-	BL	-	-
F	-	-	PL	-	-

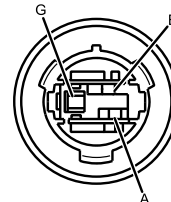

LEFT FRONT TURN SIGNAL AND
PARKING LIGHT
(LAM1203)

CAV	CIRCUIT	GAUGE	COLOR	TERMINAL	SEAL
A	57-B	14	OR	-	-
B	58-B	14	BN	-	-
G	11-B	14	WH	-	-

B235005764

Figure 77. Connector Composites (LAM1196, LAM1197, LAM1198, LAM1199, LAM1200, LAM1201, LAM1202, LAM1203).

CONNECTOR COMPOSITES - (CONTINUED)

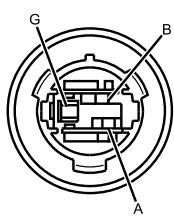

RIGHT FRONT TURN SIGNAL AND
PARKING LIGHT
(LAM1204)

CAV	CIRCUIT	GAUGE	COLOR	TERMINAL	SEAL
A	57-B	14	OR	-	-
B	58-B	14	BN	-	-
G	11-B	14	WH	-	-



DOME LAMP SWITCH
(LAM1205)

CAV	CIRCUIT	GAUGE	COLOR	TERMINAL	SEAL
1	WH LT	18	WH	0386975C2	-
2	PWR	18	LTBL	0386975C2	-
3	RD LT	18	RD	0386975C2	-

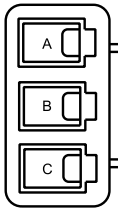

DOME LAMP SWITCH JUMPER
(LAM1206)

CAV	CIRCUIT	GAUGE	COLOR	TERMINAL	SEAL
A	PWR	18	LTBL	1661891C1	-
B	RD LT	18	RD	1661891C1	-
C	WH LT	18	WH	1661891C1	-

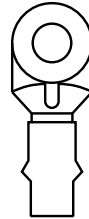

HYDRAULIC PUMP MOTOR FEED
(LAM1207)

CAV	CIRCUIT	GAUGE	COLOR	TERMINAL	SEAL
R2	24V	4	RD	08900947	-

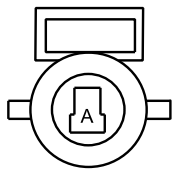

REAR TRAILER HOOKUP HARNESS
AUXILIARY POWER
(LAM1208)

CAV	CIRCUIT	GAUGE	COLOR	TERMINAL	SEAL
A	72	-	GN	-	-

MATES WITH 9783

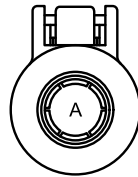

REAR TRAILER HOOKUP HARNESS
GROUND
(LAM1209)

CAV	CIRCUIT	GAUGE	COLOR	TERMINAL	SEAL
A	10	8	WH	-	-

MATES WITH 9778F

B235005765

Figure 78. Connector Composites (LAM1204, LAM1205, LAM1206, LAM1207, LAM1208, LAM1209).

CONNECTOR COMPOSITES - (CONTINUED)

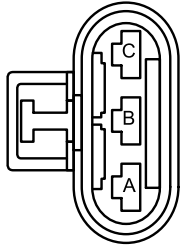

REAR TRAILER HOOKUP HARNESS
TAILLIGHTS
(LAM1210)

CAV	CIRCUIT	GAUGE	COLOR	TERMINAL	SEAL
A	70	18	RD	12084735	-
B	68	18	BN	12064735	-
C	94	18	GY	12064735	-

MATES WITH 9780M

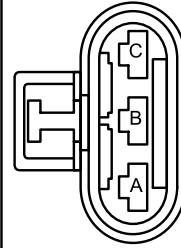

REAR TRAILER HOOKUP HARNESS
TAIL AND TURN LIGHTS
(LAM1211)

CAV	CIRCUIT	GAUGE	COLOR	TERMINAL	SEAL
A	58	18	BN	12052455	-
B	56	18	YL	12052455	-
C	57	18	DKBL	12052455	-

MATES WITH 9779F

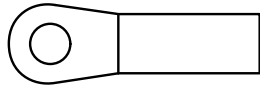

FRONT TRAILER HOOKUP HARNESS
GROUND
(LAM1212)

CAV	CIRCUIT	GAUGE	COLOR	TERMINAL	SEAL
A	10	-	WH	-	-

CONNECTS TO GROUND

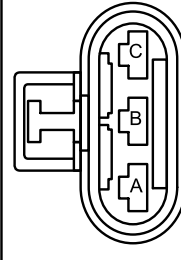

FRONT TRAILER HOOKUP HARNESS
POWER AND GROUND
(LAM1213)

CAV	CIRCUIT	GAUGE	COLOR	TERMINAL	SEAL
A	94	-	GY	-	-
B	-	-	-	-	-
C	72	-	GN	-	-

MATES WITH 9723

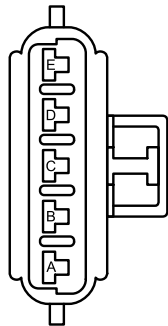

FRONT TRAILER HOOKUP HARNESS
TAIL, TURN AND BRAKE LIGHTS
(LAM1214)

CAV	CIRCUIT	GAUGE	COLOR	TERMINAL	SEAL
A	58	-	BN	-	-
B	56	-	YL	-	-
C	57	-	DKBL	-	-
D	70	-	RD	-	-
E	68	-	BN	-	-

MATES WITH 9724

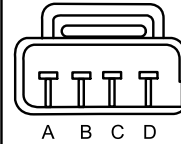

STEERING WHEEL WIRE
HARNESS CLOCK
SPRING CONNECTOR
(LAM1215)

CAV	CIRCUIT	GAUGE	COLOR	TERMINAL	SEAL
A	-	22	YL	12059894	-
B	-	22	GY	12059894	-
C	-	22	GR	12059894	-
D	-	22	BK	12059894	-



STEERING WHEEL WIRE
HARNESS HORN BUTTON
CONNECTOR
(LAM1216)

CAV	CIRCUIT	GAUGE	COLOR	TERMINAL	SEAL
A	-	22	YL	51895	-



STEERING WHEEL WIRE
HARNESS HORN BUTTON
GROUND CONNECTOR
(LAM1217)

CAV	CIRCUIT	GAUGE	COLOR	TERMINAL	SEAL
A	-	22	BK	51895	-

B235005790

Figure 79. Connector Composites (LAM1210, LAM1211, LAM1212, LAM1213, LAM1214, LAM1215, LAM1216, LAM1217).

END OF WORK PACKAGE

CHAPTER 10
SUPPORTING INFORMATION
FOR
MINE RESISTANT AMBUSH PROTECTED (MRAP)

FIELD MAINTENANCE
REFERENCES

SCOPE

This work package lists all field manuals, forms, technical manuals, and miscellaneous publications referenced in this manual.

FIELD MANUALS

FM 3-11.4	Multiservice Tactics, Techniques, and Procedures for Nuclear, Biological, and Chemical (NBC) Protection
FM 3-5	NBC Decontamination
FM 4-25.11	First Aid

FORMS

DA Form 2028	Recommended Changes to Publications and Blank Forms
DA Form 2408-9	Equipment Control Record
DA Form 5988-E	Equipment Inspection and Maintenance Worksheet
SF 361	Transportation Discrepancy Report
SF 364	Report of Discrepancy
SF 368	Product Quality Deficiency Report

DEPARTMENT OF THE ARMY PAMPHLETS

DA PAM 25-30	Consolidated Index of Army Publications and Blank Forms
DA PAM 750-8	The Army Maintenance Management System User Manual

TECHNICAL BULLETINS

TB 9-1100-803-15	Equipment Improvement Recommendation Report
------------------	---

TECHNICAL MANUALS

TM 43-0139	Painting Instructions for Army Materiel
TM 9-2355-106-10	Operator Manual for Mine Resistant Ambush Protected (MRAP)
TM 9-2355-106-23P	Field Maintenance Manual for Mine Resistant Ambush Protected (MRAP)
TM 9-4940-658-10	Forward Repair System (FRS)
TM 9-4910-783-13	Operator's, Unit, and Direct Support Maintenance Manual (Including Repair Parts and Special Tools List) for Standard Automotive Tool Set (SATS)

ARMY REGULATIONS

AR 735-11-2	Reporting of Item and Packaging Discrepancies
AR 750-1	Army Material Maintenance Policy

COMMON TABLE OF ALLOWANCES

CTA 8-100	Army Medical Department Expendable/Durable Items
CTA 50-970	Expendable/Durable items (Except Medical, Class V, Repair Parts, and Heraldic Items)

END OF WORK PACKAGE

FIELD MAINTENANCE**MAINTENANCE ALLOCATION CHART (MAC) INTRODUCTION**

The Army Maintenance System MAC

This introduction provides a general explanation of all maintenance and repair functions authorized at the two maintenance levels under the Two-Level Maintenance System concept. This MAC (immediately following the introduction) designates overall authority and responsibility for the performance of maintenance functions on the identified end item or component. The application of the maintenance functions to the end item or component shall be consistent with the capacities and capabilities of the designated maintenance levels, which are shown on the MAC in column (4) as:

Field - includes two subcolumns, Crew (C) and Maintainer (F).

Sustainment - includes two subcolumns, Below Depot (H) and Depot (D).

The maintenance to be performed at field and sustainment levels is described as follows:

1. Crew maintenance. The responsibility of a using organization to perform maintenance on its assigned equipment. It normally consists of inspecting, servicing, lubricating, adjusting, and replacing parts, minor assemblies, and subassemblies. The replace function for this level of maintenance is indicated by the letter "C" in the third position of the SMR code. A "C" appearing in the fourth position of the SMR code indicates complete repair is possible at the crew level maintenance level.
2. Maintainer maintenance. Maintenance accomplished on a component, accessory, assembly, subassembly, plug-in unit, or other portion either on the system or after it is removed. The replace function for this level of maintenance is indicated by the letter "F" appearing in the third position of the SMR code. An "F" appearing in the fourth position of the SMR code indicates complete repair is possible at the field maintenance level. Items are returned to the user after maintenance is performed at this level.
3. Below depot sustainment. Maintenance accomplished on a component, accessory, assembly, subassembly, plug-in unit, or other portion either on the system or after it is removed. The replace function for this level of maintenance is indicated by the letter "H" appearing in the third position of the SMR code. An "H" appearing in the fourth position of the SMR code indicates complete repair is possible at the below depot sustainment maintenance level. Items are returned to the supply system after maintenance is performed at this level.
4. Depot sustainment. Maintenance accomplished on a component, accessory, assembly, subassembly, plug-in unit, or other portion either on the system or after it is removed. The replace function for this level of maintenance is indicated by the letter "D" or "K" appearing in the third position of the SMR code. Depot sustainment maintenance can be performed by either depot personnel or contractor personnel. A "D" or "K" appearing in the fourth position of the SMR code indicates complete repair is possible at the depot sustainment maintenance level. Items are returned to the supply systems after maintenance is performed at this level. The tools and test equipment requirements table (immediately following the MAC) lists the tools and test equipment (both special tools and common tool sets) required for each maintenance function as referenced from the MAC. The remarks table (immediately following the tools and test equipment requirements) contains supplemental instructions and explanatory notes for a particular maintenance function.

MAINTENANCE FUNCTIONS

1. Inspect. To determine the serviceability of an item by comparing its physical, mechanical, and/or electrical characteristics with established standards through examination (e.g., by sight, sound, or feel). This includes scheduled inspection and gaugings and evaluation of cannon tubes.
2. Test. To verify serviceability by measuring the mechanical, pneumatic, hydraulic, or electrical characteristics of an item and comparing those characteristics with prescribed standards on a scheduled basis, i.e., load testing of lift devices and hydrostatic testing of pressure hoses.
3. Service. Operations required periodically to keep an item in proper operating condition; e.g., to clean (includes decontaminate, when required), to preserve, to drain, to paint, or to replenish fuel, lubricants, chemical fluids, or gases. This includes scheduled exercising and purging of recoil mechanisms. The following are examples of service functions:
 - a. Unpack. To remove from packing box for service or when required for the performance of maintenance operations.

MAINTENANCE ALLOCATION CHART (MAC) INTRODUCTION - (CONTINUED)

- b. Repack. To return item to packing box after service and other maintenance operations.
 - c. Clean. To rid the item of contamination.
 - d. Touch up. To spot paint scratched or blistered surfaces.
 - e. Mark. To restore obliterated identification.
4. Adjust. To maintain or regulate, within prescribed limits, by bringing into proper position, or by setting the operating characteristics to specified parameters.
 5. Align. To adjust specified variable elements of an item to bring about optimum or desired performance.
 6. Calibrate. To determine and cause corrections to be made or to be adjusted on instruments of test, measuring, and diagnostic equipment used in precision measurement. Consists of comparisons of two instruments, one of which is a certified standard of known accuracy, to detect and adjust any discrepancy in the accuracy of the instrument being compared.
 7. Remove/Install. To remove and install the same item when required to perform service or other maintenance functions. Install may be the act of emplacing, seating, or fixing into position a spare, repair part, or module (component or assembly) in a manner to allow the proper functioning of an equipment or system.
 8. Paint (ammunition only). To prepare and spray color coats of paint so that the ammunition can be identified and protected. The color indicating primary use is applied, preferably, to the entire exterior surface as the background color of the item. Other markings are to be repainted as original so as to retain proper ammunition identification.
 9. Replace. To remove an unserviceable item and install a serviceable counterpart in its place. "Replace" is authorized by the MAC and assigned maintenance level is shown as the third position code of the Source, Maintenance and Recoverability (SMR) code.
 10. Repair. The application of maintenance services, including fault location/troubleshooting, removal/installation, disassembly/assembly procedures and maintenance actions to identify troubles and restore serviceability to an item by correcting specific damage, fault, malfunction, or failure in a part, subassembly, module (component or assembly), end item, or system.

NOTE

The following definitions are applicable to the "repair" maintenance function:
Disassembly/assembly.

Services. Inspect, test, service, adjust, align, calibrate, and/or replace.

Fault location/troubleshooting. The process of investigating and detecting the cause of equipment malfunctioning; the act of isolating a fault within a system or Unit Under Test (UUT).

The step-by-step breakdown (taking apart) of a spare/functional group coded item to the level of its least component, that is assigned an SMR code for the level of maintenance under consideration (i.e., identified as maintenance significant).

Actions. Welding, grinding, riveting, straightening, facing, machining, and/or resurfacing.

11. Overhaul. That maintenance effort (service/action) prescribed to restore an item to a completely serviceable/operational condition as required by maintenance standards in appropriate technical publications. Overhaul is normally the highest degree of maintenance performed by the Army. Overhaul does not normally return an item to like new condition.
12. Rebuild. Consists of those services/actions necessary for the restoration of unserviceable equipment to a like new condition in accordance with original manufacturing standards. Rebuild is the highest degree of material maintenance applied to Army equipment. The rebuild operation includes the act of returning to zero those age measurements (e.g., hours/miles) considered in classifying Army equipment/components.

MAINTENANCE ALLOCATION CHART (MAC) INTRODUCTION - (CONTINUED)

Explanation Of Columns In The MAC

Column (1) Group Number. Column (1) lists Functional Group Code (FGC) numbers, the purpose of which is to identify maintenance significant components, assemblies, subassemblies, and modules with the Next Higher Assembly (NHA).

Column (2) Component/Assembly. Column (2) contains the item names of components, assemblies, subassemblies, and modules for which maintenance is authorized.

Column (3) Maintenance Function. Column (3) lists the functions to be performed on the item listed in column (2). (For a detailed explanation of these functions refer to "Maintenance Functions" outlined above).

Column (4) Maintenance Level. Column (4) specifies each level of maintenance authorized to perform each function listed in column (3), by indicating work time required (expressed as manhours in whole hours or decimals) in the appropriate subcolumn. This work time figure represents the active time required to perform that maintenance function at the indicated level of maintenance. If the number or complexity of the tasks within the listed maintenance function varies at different maintenance levels, appropriate work time figures are to be shown for each level. The work time figure represents the average time required to restore an item (assembly, subassembly, component, module, end item, or system) to a serviceable condition under typical field operating conditions. This time includes preparation time (including any necessary disassembly/assembly time), troubleshooting/fault location time, and quality assurance time in addition to the time required to perform the specific tasks identified for the maintenance functions authorized in the MAC. The symbol designations for the various maintenance levels are as follows:

Field

C Crew maintenance

F Maintainer maintenance

Sustainment

L Specialized Repair Activity (SRA)

H Below depot maintenance

D Depot maintenance

NOTE

The "L" maintenance level is not included in column (4) of the MAC. Functions to this level of maintenance are identified by work time figure in the "H" column of column (4), and an associated reference code is used in the REMARKS column (6). This code is keyed to the remarks and the SRA complete repair application is explained there.

Column (5) Tools and Equipment Reference Code. Column (5) specifies, by code, those common tool sets (not individual tools), common Test, Measurement and Diagnostic Equipment (TMDE), and special tools, special TMDE and special support equipment required to perform the designated function. Codes are keyed to the entries in the tools and test equipment table.

Column (6) Remarks Code. When applicable, this column contains a letter code, in alphabetical order, which is keyed to the remarks table entries.

Explanation Of Columns In The Tools And Test Equipment Requirements

Column (1) - Tool or Test Equipment Reference Code. The tool or test equipment reference code correlates with a code used in column (5) of the MAC.

Column (2) - Maintenance Level. The lowest level of maintenance authorized to use the tool or test equipment.

Column (3) - Nomenclature. Name or identification of the tool or test equipment.

Column (4) - National Stock Number (NSN). The NSN of the tool or test equipment.

MAINTENANCE ALLOCATION CHART (MAC) INTRODUCTION - (CONTINUED)

Column (5) - Tool Number. The manufacturer's part number.

Explanation Of Columns In The Remarks

Column (1) - Remarks Code. The code recorded in column (6) of the MAC.

Column (2) - Remarks. This column lists information pertinent to the maintenance function being performed as indicated in the MAC.

END OF WORK PACKAGE

**FIELD MAINTENANCE
MAINTENANCE ALLOCATION CHART**

Table 1. Maintenance Allocation Chart.

(1) GROUP NUMBER	(2) COMPONENT/ASSEMBLY	(3) MAINTENANCE FUNCTION	(4) MAINTENANCE LEVEL				(5) TOOLS AND EQUIPMENT REF CODE	(6) REMARKS CODE
			FIELD		SUSTAINMENT			
			CREW C	MAIN- TAI- NER F	BE- LOW DEPOT H	DEPOT D		
0100	Engine Assembly	Inspect	0.5				A	
		Service	1.0					
		Replace		45.9		7, 8, 32		
		Repair		46.9		1, 7, 8, 23, 32		
		Overhaul			36.0	1, 7, 8, 23, 32		
0100	Front Engine Mounts	Inspect		0.5				
		Replace		10.5		7, 8		
0100	Rear Engine Mounts	Inspect		1.5				
		Replace		10.7		7, 8, 30	B	
0101	Cylinder Head and Gasket	Inspect	0.5					
		Replace		42.1		7, 8, 32		
		Repair		43.1		5, 7, 8, 32, 33		
		Overhaul			8.0			
0102	Crankshaft Damper and Front Seal	Inspect	0.1					
		Replace		5.2		7, 8, 16, 17, 32		
0102	Rear Crankshaft Oil Seal	Inspect		0.1				
		Replace		19.2		7, 8, 18, 29, 44	F	
0103	Flex Plate	Inspect		0.5				
		Replace		17.7		7, 8, 9		
0103	Starter Ring Gear	Inspect		0.5				
		Replace		17.6		7, 8		
0105	Front Engine Cover	Inspect	0.5					
		Replace		27.1		8, 32		
0105	Valve Cover and Gasket	Inspect		0.5				
		Replace		5.3		8, 32		
0105	Engine Valve Adjustment	Inspect		2.0				
		Service		6.3		8, 9	C	
0106	Oil Gauge Tube	Inspect		0.5				
		Replace		8.4		9		
0106	Engine Oil Breather Tube	Inspect		0.1				
		Replace		2.4		8		
0106	Engine Oil Filter	Inspect	0.1					
		Replace		8.8		7, 8, 32		
0106	Engine Oil Drain/Fill Procedure	Service		8.3		8, 32		
0106	Engine Oil Cooler	Inspect		0.5				
		Replace		19		8, 32	D	

MAINTENANCE ALLOCATION CHART - (CONTINUED)

(1) GROUP NUMBER	(2) COMPONENT/ASSEMBLY	(3) MAINTENANCE FUNCTION	(4) MAINTENANCE LEVEL				(5) TOOLS AND EQUIPMENT REF CODE	(6) REMARKS CODE
			FIELD		SUSTAINMENT			
			CREW C	MAIN-TAI- NER F	BE- LOW DEPOT H	DEPOT D		
0106	Engine Oil Cooler Pressure Regulator	Inspect		3.1				
		Replace		19.1		8		
0106	Engine Oil Pan	Inspect		2.5				
		Replace		10.2		7, 8, 32		
0106	Engine Oil Pickup Tube	Inspect		10.2				
		Replace		15.9		8, 32		
0106	Front Oil Pump	Inspect		0.5				
		Replace		13.9		8		
		Repair		14.9		8		
0108	Exhaust Manifold	Inspect		0.5				
		Replace		18		7, 8		
0109	Serpentine Belt	Inspect	0.1					
		Replace		0.7		8		
0109	Serpentine Belt Idler Pulley	Inspect		0.2				
		Replace		0.9		8, 32		
0109	Serpentine Belt Tensioner	Inspect	0.1					
		Replace		0.8		8		
0109	Serpentine Belt Upper Idler Pulley	Inspect	0.1					
		Replace		0.8		8		
0109	Air Conditioner (A/C) Belt	Inspect	0.1					
		Replace		0.5		7, 8		
0109	Air Conditioner (A/C) Belt Tensioner	Inspect		0.1				
		Replace		0.6		8		
0112	Exhaust Brake	Inspect		0.5				
		Replace		9.5		8		
		Repair		10.5		9		
0112	Exhaust Brake Solenoid	Inspect		0.2				
		Replace		0.9		8		
		Repair		1.9		9		
0112	Exhaust Brake Supply Air Line	Inspect		0.2				
		Replace		4.2		8, 32		
0301	Fuel Injector	Inspect		0.5				
		Replace		5.6		8, 32		
		Repair		6.6		8, 22, 32		
0301	Oil/Fuel Manifold	Inspect		0.3				
		Replace		6.8		8, 32		
		Repair		7.8		8, 32		
0301	Fuel Pressure Regulator	Inspect		1.0				

MAINTENANCE ALLOCATION CHART - (CONTINUED)

(1) GROUP NUMBER	(2) COMPONENT/ASSEMBLY	(3) MAINTENANCE FUNCTION	(4) MAINTENANCE LEVEL				(5) TOOLS AND EQUIPMENT REF CODE	(6) REMARKS CODE
			FIELD		SUSTAINMENT			
			CREW	MAIN-TAI-NER	BE-LOW DEPOT	DEPOT		
			C	F	H	D		
		Replace		3.4			7, 8	
		Repair		4.4			7, 8, 23	
0302	High Pressure Injector Pump	Inspect		0.1				
		Replace		5.1			7, 8, 32	
		Repair		6.1			7, 8, 32	
0302	Fuel Pump	Inspect	1.0					
		Replace		3.1			7, 8, 32	
		Repair		4.1			7, 8, 23, 32	
0302	Fuel Filter Header/Primer Pump	Inspect	0.2					
		Replace		12.0			7, 8, 32	
		Repair		13.0			7, 8, 23, 32	
0302	Fuel Primer Sequence	Service		0.8			8	
0304	Air Intake Tube (To Turbo)	Inspect	0.1					
		Replace		0.2			8	
0304	Air Cleaner Assembly	Inspect	0.1					
		Service	0.2				8	
		Replace	0.5				8	
0304	Air Cleaner Support	Inspect		0.7				
		Replace		2.2			7, 8	
0304	Air Filter Restriction Gauge	Inspect	0.1					
		Replace		1.3			8	
0304	Center Panel Air Filter Restriction Gauge Tubing and Fitting	Inspect	0.1					
		Replace		4.4			8	
0305	Turbocharger Assembly	Inspect		0.5				
		Replace		11.0			8	
		Repair		12.0			8, 23	
		Overhaul				2.5		
0305	Turbocharger Lubricant Lines	Inspect	0.1					
		Replace		0.7			8	
0305	Charge Air Cooler (CAC) Assembly	Inspect	0.1					
		Service	0.5					
		Replace		4.8			7, 8, 32	
0305	Charge Air Cooler (CAC) Hose	Inspect	0.1					
		Replace		1.3			8, 32	

MAINTENANCE ALLOCATION CHART - (CONTINUED)

(1) GROUP NUMBER	(2) COMPONENT/ASSEMBLY	(3) MAINTENANCE FUNCTION	(4) MAINTENANCE LEVEL				(5) TOOLS AND EQUIPMENT REF CODE	(6) REMARKS CODE
			FIELD		SUSTAINMENT			
			CREW C	MAIN- TAIN- NER F	BE- LOW DEPOT H	DEPOT D		
0306	Fuel Tank	Inspect	0.2					
		Replace		11			8, 32	
0306	Fuel Tank Bracket	Inspect	0.2	0.2				
		Replace		15.4			8	
0306	Fuel Tank Strap	Inspect		0.2				
		Replace		13.2			8	
0306	Fuel Hose	Inspect	0.2					
		Replace		13.3			7, 8, 32	
0309	Fuel Filter and Strainer	Inspect		0.3				
		Replace		1.1			8, 32	
0309	Fuel/Water Separator Filter	Inspect	0.1					
		Service	0.2				8, 32	
		Replace		1.0			8, 32	
0309	Fuel/Water Separator Assembly Purge	Inspect	0.1					
		Service		1.4			8, 32	
0311	Ether (Cold) Start Valve and Atomizer Assembly	Inspect		0.5				
		Replace		0.9			8	
		Repair		1.9			8	
0311	Ether Canister	Inspect	0.1					
		Replace		0.4			8	
0311	Ether Cold Start Thermostatic Switch	Inspect	0.1					
		Replace		3.5			8	
		Repair		4.5			8, 40	
0401	Exhaust Pipe	Inspect	0.3					
		Replace		14.3			8	
0401	Muffler and Shield	Inspect	0.2					
		Replace		3.8			7, 8	
0501	Cooling System Drain and Fill Procedure	Service		1.0			8, 32, 40	
0501	Radiator Assembly Cleaning Procedure	Service	0.2					
0501	Radiator	Inspect	0.2					
		Service	0.2					
		Replace		7.7			7, 8, 30, 32	
0501	Deaeration Tank	Inspect	0.1					
		Replace		1.3			8, 32	
0501	Deaeration Tank Pressure Cap	Inspect	0.1					
		Replace	1.1					

MAINTENANCE ALLOCATION CHART - (CONTINUED)

(1) GROUP NUMBER	(2) COMPONENT/ASSEMBLY	(3) MAINTENANCE FUNCTION	(4) MAINTENANCE LEVEL				(5) TOOLS AND EQUIPMENT REF CODE	(6) REMARKS CODE
			FIELD		SUSTAINMENT			
			CREW	MAIN-TAI-NER	BE-LOW DEPOT	DEPOT		
			C	F	H	D		
0501	Radiator Surge Overflow Tank	Inspect	0.1					
		Replace		0.3			8, 32	
0502	Radiator Fan and Fan Shroud	Inspect	0.1					
		Replace		2.7			8, 32	
0503	Thermostat	Inspect		0.5				
		Replace		1.5			7, 8	
		Repair		2.5			7, 8	
0503	Water Inlet Elbow	Inspect	0.2					
		Replace		9.3			8, 32	
0503	Radiator Pipes/Hoses	Inspect	0.2					
		Replace		3.4			8, 32	
0504	Engine Water Pump	Inspect		0.2				
		Replace		7.3			8, 32	
0505	Cooling Fan Drive Assembly	Inspect		0.2				
		Replace		3.6			8, 32	
		Repair		4.6			8, 22, 32	
0505	Cooling Fan Actuator Solenoid	Inspect		0.2				
		Replace		0.4			8	
		Repair		1.4			8, 22	
0601	Alternator	Inspect	0.1					
		Replace		3.2			7, 8	
		Repair		4.2			7, 8	
		Overhaul				3.0		
0601	Alternator Bracket	Inspect	0.1					
		Replace		4.8			8, 32	
0601	Alternator Pulley	Inspect		0.1				
		Replace		1.0			7, 8	
0603	Starter Motor	Inspect	0.1					
		Replace		10.6			8	
		Repair		11.6			8	
		Overhaul				2.5		
0607	Transmission Fluid Temperature Gauge and Harness	Inspect	0.1					
		Replace		2.5			8	
		Repair		3.5			8	

MAINTENANCE ALLOCATION CHART - (CONTINUED)

(1) GROUP NUMBER	(2) COMPONENT/ASSEMBLY	(3) MAINTENANCE FUNCTION	(4) MAINTENANCE LEVEL				(5) TOOLS AND EQUIPMENT REF CODE	(6) REMARKS CODE
			FIELD		SUSTAINMENT			
			CREW C	MAIN-TAI- NER F	BE- LOW DEPOT H	DEPOT D		
0607	Air 1 Pressure Gauge and Harness	Inspect		0.1				
		Replace		2.5		8		
		Repair		3.5		8, 22		
0607	Air 2 Pressure Gauge and Harness	Inspect		0.1				
		Replace		2.5		8		
		Repair		3.5		8, 22		
0607	Battery Main Power Switch	Inspect	0.1					
		Replace		1.0		8		
		Repair		2.0		8		
0607	Instrument Panel Cluster (IPC)	Inspect	0.1					
		Replace		2.3		8		
		Repair		3.3		8, 22, 40		
0607	Instrument Panel Cluster (IPC) Right Side Warning Panel	Inspect	0.1					
		Replace		2.5		8		
		Repair		3.5		8		
0607	Instrument Panel (IP) Light Bulb	Inspect	0.1					
		Replace		2.7		8		
		Repair		3.7		8		
0607	Rocker Switch	Inspect	0.1					
		Replace		0.2		6, 8		
		Repair		1.2		6, 8, 22		
0607	Keyless Ignition Switch	Inspect	0.1					
		Replace		1.4		8		
		Repair		2.4		8		
0607	Master Vehicle Light Switch (MVLS)	Inspect	0.1					
		Replace		0.6		8		
		Repair		1.6		8, 40		
0607	24V Gauge	Inspect	0.1					
		Replace		1.7		8		
		Repair		2.7		8		
0607	24V Gauge Bulb	Inspect	0.1					
		Replace		0.7		8		
		Repair		1.7		8		
0607	Mirror Remote Control Switch	Inspect	0.1					
		Replace		0.7		8		
		Repair		1.7		8		

MAINTENANCE ALLOCATION CHART - (CONTINUED)

(1) GROUP NUMBER	(2) COMPONENT/ASSEMBLY	(3) MAINTENANCE FUNCTION	(4) MAINTENANCE LEVEL				(5) TOOLS AND EQUIPMENT REF CODE	(6) REMARKS CODE
			FIELD		SUSTAINMENT			
			CREW	MAIN- TAIN- NER	BE- LOW DEPOT	DEPOT		
			C	F	H	D		
0607	Master Vehicle Light Switch (MVLS) Ground Harness	Inspect	0.1					
		Replace		0.7			8, 32	
		Repair		1.7			8, 32, 40	
0607	Infrared (IR) Light Switch	Inspect	0.1					
		Replace		0.8			8	
		Repair		1.8			8	
0607	Master Rear Door/Ramp Switch	Inspect	0.1					
		Replace		0.7			8	
		Repair		1.7			8	
0607	Master Rear Door/Ramp Switch Jumper Harness	Inspect	0.1					
		Replace		0.7			8, 32	
		Repair		1.7			8	
0607	Master Crew Light Switch	Inspect	0.1					
		Replace		0.8			8	
		Repair		1.8			8	
0607	Master Crew Light Switch Jumper Harness	Inspect	0.1					
		Replace		0.8			8, 32	
		Repair		1.8			8, 32, 40	
0607	Spotlight Control	Inspect	0.1					
		Replace		0.7			8	
		Repair		1.7			8, 40	
0607	Mirror Remote Control Switch Wiring Harness	Inspect	0.2					
		Replace		0.8			7, 8, 30, 32	
		Repair		1.8			7, 8, 32	
0608	Antilock Brake System (ABS) Blink Code Switch	Inspect	0.1					
		Replace		1.0			8	
		Repair		2.0			8	
0608	Cruise Control Switch Module	Inspect	0.1					
		Replace		0.5			8	
		Repair		1.5			8	
0608	Instrument Panel (IP) Circuit Breaker, Fuse, and Relay	Inspect		0.1				
		Replace		0.4			8	

MAINTENANCE ALLOCATION CHART - (CONTINUED)

(1) GROUP NUMBER	(2) COMPONENT/ASSEMBLY	(3) MAINTENANCE FUNCTION	(4) MAINTENANCE LEVEL				(5) TOOLS AND EQUIPMENT REF CODE	(6) REMARKS CODE
			FIELD		SUSTAINMENT			
			CREW	MAIN-TAI-NER	BE-LOW DEPOT	DEPOT		
			C	F	H	D		
		Repair		1.4			8, 40	
0608	Instrument Panel (IP) Center Relay	Inspect		0.1				
		Replace		0.7			8	
		Repair		1.7			8, 40	
0608	Instrument Panel (IP) Harness	Inspect		0.1				
		Replace		11.8			8	
		Repair		12.8			8, 36, 40	
0608	Cabin Electrical Ground Stud Plate	Inspect	0.1					
		Replace		1.3			7, 8	
		Repair		2.3			7, 8	
0608	Air Gauge Transducer	Inspect		0.1				
		Replace		0.4			8	
		Repair		1.4			8	
0608	Multifunction Turn Signal Switch Assembly	Inspect	0.1					
		Replace		1.3			8	
		Repair		2.3			8, 40	
0608	Steering Column Wiring Harness	Inspect		0.5				
		Replace		2.6			8	
		Repair		3.6			8, 40	
0608	Steering Wheel Wire Harness	Inspect		0.5				
		Replace		0.8			8	
		Repair		1.8			8, 40	
0608	Brake Stoplight Switch	Inspect		0.1				
		Replace		0.2			8	
		Repair		1.2			8	
0608	Parking Brake Lamp Transducer	Inspect	0.1					
		Replace		0.4			8	
		Repair		1.4			8, 22, 40	
0608	110V Cover, Outlet, and Box	Inspect	0.1					
		Replace		0.3			8	
		Repair		1.3			8	
0608	Engine Control Module (ECM)	Inspect		1.0				
		Replace		11.1			8	
		Repair		12.1			8, 14, 40	
0608	Engine Sensor Wiring Harness	Inspect	0.1					

MAINTENANCE ALLOCATION CHART - (CONTINUED)

(1) GROUP NUMBER	(2) COMPONENT/ASSEMBLY	(3) MAINTENANCE FUNCTION	(4) MAINTENANCE LEVEL				(5) TOOLS AND EQUIPMENT REF CODE	(6) REMARKS CODE
			FIELD		SUSTAINMENT			
			CREW	MAIN- TAI- NER	BE- LOW DEPOT	DEPOT		
			C	F	H	D		
		Replace		16.1			8	
		Repair		17.1			8, 34, 40	
0608	Fuel Injector Harness	Inspect		0.5				
		Replace		5.1			8	
		Repair		6.1			8, 12, 22	
0608	Air Conditioning (A/C) Condenser Fan Motor Relay	Inspect		0.1				
		Replace		0.4			8	
		Repair		1.4			8, 40	
0608	Instrument Panel (IP) Harness Terminating Resistor	Inspect		0.1				
		Replace		0.5			8	
		Repair		1.5			8	
0608	Power Distribution Center (PDC) Fuse and Relay	Inspect		0.1				
		Replace		1.0			8	
		Repair		2.0			8, 13, 40	
0608	Power Distribution Center (PDC) Junction Box	Inspect	0.1					
		Replace		1.0			8	
		Repair		2.0			8, 40	
0608	Power Distribution Center (PDC) Harness	Inspect	0.1					
		Replace		7.6			8	
		Repair		8.6			8, 13, 40	
0608	Engine Wiring Harness	Inspect	0.1					
		Replace		19.6				
		Repair		20.6			7, 8	
0608	Engine Wiring Harness Terminating Resistor	Inspect		0.1				
		Replace		8.3			8	
		Repair		9.3			8, 40	
0608	Starter Motor-to-Engine Ground Jumper Harness	Inspect	0.1					
		Replace		9.3			8	
		Repair		10.3			8	
0608	Starter Motor-to-Frame Ground Jumper Cable	Inspect	0.1					
		Replace		9.1			8	
		Repair		10.1			8	

MAINTENANCE ALLOCATION CHART - (CONTINUED)

(1) GROUP NUMBER	(2) COMPONENT/ASSEMBLY	(3) MAINTENANCE FUNCTION	(4) MAINTENANCE LEVEL				(5) TOOLS AND EQUIPMENT REF CODE	(6) REMARKS CODE
			FIELD		SUSTAINMENT			
			CREW	MAIN-TAI-NER	BE-LOW DEPOT	DEPOT		
			C	F	H	D		
0608	Alternator Interconnect Positive Cable	Inspect	0.1					
		Replace		1.1			7, 8	
		Repair		2.1			7, 8	
0608	12V and 24V Battery Disconnect Switch Solenoid	Inspect	0.1					
		Replace		1.6			8	
		Repair		2.6			8	
0608	12V Battery Disconnect Switch Solenoid Feed Cable	Inspect	0.1					
		Replace		1.3			8	
		Repair		2.3			8	
0608	24V Battery Disconnect Switch Solenoid Feed Cable	Inspect	0.1					
		Replace		1.3			8	
		Repair		2.3			8	
0608	Winch Megafuse Feed Cable	Inspect	0.1					
		Replace		1.2			8	
		Repair		2.2			8	
0608	Inverter Disconnect Battery Switch Solenoid Harness	Inspect	0.1					
		Replace		2.0			8	
		Repair		3.0			8	
0608	12 to 24V Disconnect Battery Switch Solenoid Feed Harness	Inspect	0.1					
		Replace		1.3			8	
		Repair		2.3			8	
0608	12V to 24V Disconnect Battery Switch Solenoid Ground Harness	Inspect	0.1					
		Replace		1.3			8	
		Repair		2.3			8	
0608	24V Body Feed Harness	Inspect	0.1					
		Replace		3.1			8	
		Repair		4.1			8	
0608	Equalizer Cables	Inspect	0.1					
		Replace		1.1			8	
		Repair		2.1				
0608	Battery Equalizer	Inspect		1.0				
		Replace		13.5			8	

MAINTENANCE ALLOCATION CHART - (CONTINUED)

(1) GROUP NUMBER	(2) COMPONENT/ASSEMBLY	(3) MAINTENANCE FUNCTION	(4) MAINTENANCE LEVEL				(5) TOOLS AND EQUIPMENT REF CODE	(6) REMARKS CODE
			FIELD		SUSTAINMENT			
			CREW	MAIN- TAIN- NER	BE- LOW DEPOT	DEPOT		
			C	F	H	D		
		Repair		14.5			7, 8	
0608	Master Disconnect Harness	Inspect		0.1				
		Replace		14.8			8	
		Repair		15.8			8	
0608	110V Inverter	Inspect	0.1					
		Replace		0.4			8	
		Repair		1.4			8, 40	
0608	Electronic System Controller (ESC)	Inspect	0.1					
		Replace		1.2			8	
		Repair		2.2			4, 8, 22, 40	
0608	Electronic System Controller (ESC) Brace	Inspect	0.1					
		Replace		2.0			7, 8	
0608	Antilock Brake System (ABS) Control Module	Inspect	0.1					
		Replace		1.0			8	
		Repair		2.0			8, 22, 40	
0609	Front Crew Light	Inspect	0.1					
		Replace		0.2			8	
		Repair		1.2			8	
0609	Rear Crew Light	Inspect	0.1					
		Replace		0.2			8	
		Repair		1.2			8	
0609	Interior Lights Crew Light Limit Switch and Jumper Harness	Inspect	0.1					
		Replace		0.3			8	
		Repair		1.3			8, 40	
0609	Interior Lights Left Rear Crew Light Harness	Inspect	0.1					
		Replace		0.2			8	
		Repair		1.2			8, 40	
0609	Interior Lights Right Rear and Front Crew Lights Harness	Inspect	0.1					
		Replace		2.0			8	
		Repair		3.0			8, 40	
0609	Front Bumper Turn Signal and Parking Light Assembly	Inspect	0.1					
		Replace		0.4			8	

MAINTENANCE ALLOCATION CHART - (CONTINUED)

(1) GROUP NUMBER	(2) COMPONENT/ASSEMBLY	(3) MAINTENANCE FUNCTION	(4) MAINTENANCE LEVEL				(5) TOOLS AND EQUIPMENT REF CODE	(6) REMARKS CODE
			FIELD		SUSTAINMENT			
			CREW C	MAIN- TAIN- NER F	BE- LOW DEPOT H	DEPOT D		
		Repair		1.4			8, 40	
0609	Spotlight Light Bulb	Inspect	0.1					
		Replace		0.2			8	
		Repair		1.2			8	
0609	Spotlight	Inspect	0.1					
		Replace		0.4			8	
		Repair		1.4			8, 40	
0609	Spotlight Exterior Harness	Inspect	0.1					
		Replace		0.2			8, 40	
		Repair		1.2			8, 40	
0609	Spot Light Interior Harness	Inspect	0.1					
		Replace		4.9			8	
		Repair		5.9			8, 40	
0609	Blackout Drive Light Assembly	Inspect	0.1					
		Replace		0.4			8	
		Repair		1.4			8, 40	
0609	Clearance and Marker Light Harness	Inspect	0.1					
		Replace		0.4			8	
		Repair		1.4			8, 40	
0609	Infrared (IR) Light	Inspect	0.1					
		Replace		0.1			8	
		Repair		1.1			8, 40	
0609	Front Clearance Light Assembly	Inspect	0.1					
		Replace		1.9			8	
		Repair		2.9			8	
0609	Front Clearance Light Bar Harness	Inspect	0.1					
		Replace		0.3			8	
		Repair		1.3			8, 40	
0609	Front Fender Light Assembly	Inspect	0.1					
		Replace		0.3			8	
		Repair		1.3			8	
0609	Front Fender Light Bulb	Inspect	0.1					
		Replace		0.3				
		Repair		1.3				
0609	Front Turn Signal and Parking Light Bulb	Inspect	0.1					
		Replace		0.1			8	

MAINTENANCE ALLOCATION CHART - (CONTINUED)

(1) GROUP NUMBER	(2) COMPONENT/ASSEMBLY	(3) MAINTENANCE FUNCTION	(4) MAINTENANCE LEVEL				(5) TOOLS AND EQUIPMENT REF CODE	(6) REMARKS CODE
			FIELD		SUSTAINMENT			
			CREW	MAIN- TAI- NER	BE- LOW DEPOT	DEPOT		
			C	F	H	D		
		Repair		1.1			8, 40	
0609	Front Bumper Left Harness	Inspect	0.1					
		Replace		0.5			8	
		Repair		1.5			8, 40	
0609	Front Bumper Right Harness	Inspect	0.1					
		Replace		0.5			8	
		Repair		1.5			8, 40	
0609	Headlamp	Inspect	0.1					
		Replace		0.5			8	
		Repair		1.5			8	
0609	Headlamp Alignment Procedure	Align		0.5			8	
0609	Left Headlamp and Turn Signal Harness	Inspect	0.1					
		Replace		0.9			8	
		Repair		1.9			8, 40	
0609	Right Headlamp and Turn Signal Harness	Inspect	0.1					
		Replace		0.9			8	
		Repair		1.9			8, 40	
0609	Headlamp Assembly	Inspect	0.1					
		Replace		1.0			8	
		Repair		2.0			8, 40	
0609	Headlamp Bezel	Inspect	0.1					
		Replace		1.1			8	
0609	Back-up Light Assembly	Inspect	0.1					
		Replace		0.5			8	
		Repair		1.5			8	
0609	Composite Taillamp Assembly	Inspect	0.1					
		Replace		0.5			8	
		Repair		1.5			8	
0609	Taillamp Harness	Inspect	0.1					
		Replace		0.3			8	
		Repair		1.3			8	
0609	Rear Clearance Light Assembly	Inspect	0.1					
		Replace		1.0			8	
		Repair		2.0			8	

MAINTENANCE ALLOCATION CHART - (CONTINUED)

(1) GROUP NUMBER	(2) COMPONENT/ASSEMBLY	(3) MAINTENANCE FUNCTION	(4) MAINTENANCE LEVEL				(5) TOOLS AND EQUIPMENT REF CODE	(6) REMARKS CODE
			FIELD		SUSTAINMENT			
			CREW	MAIN-TAI-NER	BE-LOW DEPOT	DEPOT		
			C	F	H	D		
0609	Rear Clearance Light Bar Harness	Inspect	0.1					
		Replace		0.5			8	
		Repair		1.5			8, 40	
0609	Rear Sidemarkers Light	Inspect	0.1					
		Replace		1.7			8	
		Repair		2.7			8	
0610	Engine Coolant Temperature (ECT) Sensor	Inspect	0.1					
		Replace		6.1			7, 8, 32	
		Repair		7.1			7, 8, 32, 34	
0610	Engine Oil Temperature (EOT) Sensor		0.1					
		Replace		0.1				
		Repair		1.1			8	
0610	Manifold Absolute Pressure (MAP) Sensor	Inspect	0.1					
		Replace		0.1			8	
		Repair		1.1			8, 8, 22, 35	
0610	Injection Control Pressure (ICP) Sensor	Inspect	0.1					
		Replace		0.1			8, 32	
		Repair		1.1			8, 22, 32, 35, 38, 40	
0610	Engine Oil Pressure (EOP) Sensor	Inspect	0.1					
		Replace		1.7			7, 8, 32	
		Repair		2.7			7, 8, 23, 32, 35	
0610	Camshaft Position (CMP) Sensor	Inspect		0.2				
		Replace		0.2			8, 32	
		Repair		1.2			8, 32	
0610	Transfer Case Mode Switch	Inspect		0.2				
		Replace		0.4			8	
		Repair		1.4			8	
0610	Transfer Case Vehicle Speed Sensor (VSS)	Inspect		0.2				
		Replace		2.6			8	
0610	Injection Pressure Regulator (IPR) Sensor	Inspect	0.1					
		Replace		5.3			7, 8, 32	
		Repair		6.3			7, 8, 22, 32	
0610	Accelerator Pedal (APS) Sensor	Inspect		0.1				

MAINTENANCE ALLOCATION CHART - (CONTINUED)

(1) GROUP NUMBER	(2) COMPONENT/ASSEMBLY	(3) MAINTENANCE FUNCTION	(4) MAINTENANCE LEVEL				(5) TOOLS AND EQUIPMENT REF CODE	(6) REMARKS CODE
			FIELD		SUSTAINMENT			
			CREW	MAIN- TAI- NER	BE- LOW DEPOT	DEPOT		
			C	F	H	D		
		Replace		0.6			8	
		Repair		1.6			8, 36	
0610	Barometric Pressure Sensor	Inspect		0.1				
		Replace		2.6			8	
		Repair		3.6			8	
0610	Intake Air Temperature (IAT) Sensor	Inspect	0.1					
		Replace		0.2			8	
		Repair		1.2			8, 22, 34, 40	
0610	Fuel Level Sending Unit	Inspect		0.2				
		Replace		19.7			8	
		Repair		20.7			8, 23	
0610	Water Sensor Probe	Inspect	0.1					
		Replace		0.2			8, 32	
		Repair		1.2			8, 32	
0611	Electric Horn	Inspect	0.1					
		Replace		0.2			8	
		Repair		1.2			8	
0611	Horn Button Assembly	Inspect	0.1					
		Replace		0.3			8	
		Repair		1.3			8, 40	
0612	Battery Disconnect Procedure	Service		0.8			7, 8	
0612	Battery Cable and Clean Power Harness	Inspect		0.1				
		Replace		1.0			7, 8	
		Repair		2.0			7, 8, 40	
0612	Engine Control Module (ECM) and Transmission Control Module (TCM) Clean Power and Ground Harness	Inspect		0.1				
		Replace		9.2			8	
		Repair		10.2			8, 22, 40	
0612	Battery Cables	Inspect		0.1				
		Replace		2.1			7, 8	
		Repair		3.1			7, 8	
0612	Body Ground to Firewall Ground Cable	Inspect		0.1				
		Replace		1.4			8	
		Repair		2.4			8	

MAINTENANCE ALLOCATION CHART - (CONTINUED)

(1) GROUP NUMBER	(2) COMPONENT/ASSEMBLY	(3) MAINTENANCE FUNCTION	(4) MAINTENANCE LEVEL				(5) TOOLS AND EQUIPMENT REF CODE	(6) REMARKS CODE
			FIELD		SUSTAINMENT			
			CREW	MAIN-TAI-NER	BE-LOW DEPOT	DEPOT		
			C	F	H	D		
0612	Battery Stud Adapter Terminal Clamp	Inspect		0.1				
		Replace		2.3			7, 8, 32	
0612	Battery Body Ground Cable	Inspect		0.1				
		Replace		1.0			8	
		Repair		2.0			8	
0612	Instrument Panel (IP) Feed Harness	Inspect		0.1				
		Replace		10.1			8	
		Repair		11.1			8	
0612	Engine Control Module (ECM) and Transmission Control Module (TCM) Clean Power Fuse	Inspect		0.1				
		Replace		0.5			8	
0612	Starter Motor-to-Battery Feed Cable	Inspect		0.1				
		Replace		9.3			8	
		Repair		10.3			8, 40	
0612	Starter Motor-to-Battery Ground Cable	Inspect		0.1				
		Replace		9.3			8	
		Repair		10.3			8	
0612	Winch Battery Cable Junction Block and Bracket Support	Inspect		0.1				
		Replace		1.0			8	
0612	Winch Feed Cable	Inspect		0.1				
		Replace		1.1			8	
		Repair		2.1			8	
0612	Winch Ground Cable	Inspect		0.1				
		Replace		1.2			8	
		Repair		2.2			8	
0612	Battery	Inspect		0.5				
		Service	0.5					
		Replace		2.7			8	
		Repair		3.7			8	
0612	Battery Box	Inspect		0.5				
		Replace		16.2			8	
0613	NATO Jump Start Connector	Inspect	0.1					
		Service	0.2					
		Replace		1.4			8	
		Repair		2.4			8	

MAINTENANCE ALLOCATION CHART - (CONTINUED)

(1) GROUP NUMBER	(2) COMPONENT/ASSEMBLY	(3) MAINTENANCE FUNCTION	(4) MAINTENANCE LEVEL				(5) TOOLS AND EQUIPMENT REF CODE	(6) REMARKS CODE
			FIELD		SUSTAINMENT			
			CREW	MAIN- TAI- NER	BE- LOW DEPOT	DEPOT		
			C	F	H	D		
0613	12V Underhood Megafuse and Holder	Inspect	0.1					
		Replace		1.4			7, 8	
		Repair		2.4			7, 8	
0613	24 Volt Underhood Junction Block	Inspect	0.1					
		Replace		1.1			7, 8	
0613	Forward Chassis Wiring Harness	Inspect	0.1					
		Replace		2.9			8	
		Repair		3.9			8, 40	
0613	Front Antilock Braking System (ABS) Sensor	Inspect		1.5				
		Replace		0.4			8, 32	
		Repair		1.4			8, 22, 32, 40	
0613	Center Chassis Wiring Harness	Inspect		0.1				
		Replace		10.2			8	
0613	Rear Chassis Harness	Inspect		0.1				
		Replace		1.2			8	
		Repair		2.2			8, 40	
0613	Front Trailer Hookup Cover	Inspect	0.1					
		Replace		0.3			8	
		Repair		1.3			8	
0613	Front Trailer Hookup Harness	Inspect	0.1					
		Replace		1.4			8	
		Repair		2.4			8, 40	
0613	Rear Trailer Hookup Cover	Inspect	0.1					
		Replace		0.5			8	
		Repair		1.5			8	
0613	Rear Trailer Hookup Harness	Inspect	0.1					
		Replace		0.7			8	
		Repair		1.7			8, 40	
0613	Rear Door Ramp Hydraulic System Control Harness	Inspect		0.2				
		Replace		2.4			7, 8	
		Repair		3.4			7, 8, 40	

MAINTENANCE ALLOCATION CHART - (CONTINUED)

(1) GROUP NUMBER	(2) COMPONENT/ASSEMBLY	(3) MAINTENANCE FUNCTION	(4) MAINTENANCE LEVEL				(5) TOOLS AND EQUIPMENT REF CODE	(6) REMARKS CODE
			FIELD		SUSTAINMENT			
			CREW C	MAIN-TAI-NER F	BE-LOW DEPOT H	DEPOT D		
0613	Rear Door Ramp Hydraulic System Harness (Push-Type Operation)	Inspect		0.2				
		Replace		0.6			8	
		Repair		1.6			8, 40	
0613	Rear Door Ramp Hydraulic System Harness (Pull-Type Operation)	Inspect		0.2				
		Replace		0.7			8	
		Repair		1.7			8, 40	
0613	110V Outlet Harness	Inspect	0.1					
		Replace		2.0			8	
		Repair		3.0			8, 40	
0613	24V Instrument Panel (IP) Feed Harness	Inspect		0.1				
		Replace		0.4			8	
		Repair		1.4			8, 40	
0613	24V Power Distribution Module (PDM) Feed Harness	Inspect		0.1				
		Replace		0.7			8	
		Repair		1.7			8, 40	
0613	24V Power Distribution Module (PDM) Ground Cable	Inspect		0.1				
		Replace		0.4			8	
		Repair		1.4			8	
0613	Left 12V Socket and Feed Harness	Inspect	0.1					
		Replace		1.0			8	
		Repair		2.0			8, 40	
0613	Right 12V Socket and Feed Harness	Inspect	0.1					
		Replace		2.0			8	
		Repair		3.0			8, 40	
0613	Front and Rear Clearance Lights Roof Harness	Inspect	0.1					
		Replace		4.8			8	
		Repair		5.8			8, 40	
0613	Clearance Lights Cabin Jumper Harness	Inspect	0.1					
		Replace		2.1			8	
		Repair		3.1			8, 40	
0613	Electrical Wire Repair	Inspect		0.3				
		Repair		0.3			7, 8, 32	

MAINTENANCE ALLOCATION CHART - (CONTINUED)

(1) GROUP NUMBER	(2) COMPONENT/ASSEMBLY	(3) MAINTENANCE FUNCTION	(4) MAINTENANCE LEVEL				(5) TOOLS AND EQUIPMENT REF CODE	(6) REMARKS CODE
			FIELD		SUSTAINMENT			
			CREW	MAIN-TAI-NER	BE-LOW DEPOT	DEPOT		
			C	F	H	D		
0613	24 Volt Power Distribution Module (PDM)	Inspect	0.1					
		Replace		3.2		8		
		Repair		4.2		8, 32		
0613	Rear Door Ramp Feed Harness	Inspect	0.1					
		Replace		11.4		8		
		Repair		12.4		8, 40		
0613	24V Government Furnished Equipment (GFE) Harness	Inspect	0.1					
		Replace		1.2		8		
		Repair		2.2		8		
0613	Turret Power Feed Harness	Inspect	0.1					
		Replace		1.3		8		
		Repair		2.3		8		
0618	110V Inverter Main Power Switch	Inspect	0.1					
		Replace		0.8		8		
		Repair		1.8		8		
0618	Winch Megafuse and Holder	Inspect	0.1					
		Replace		1.0		8		
		Repair		2.0		8		
0618	24V Inverter Megafuse and Holder	Inspect		0.5				
		Replace		1.8		8		
		Repair		2.8		8		
0618	Inverter and Main Power Switch Solenoid Cables	Inspect	0.1					
		Replace		2.2		8		
		Repair		3.2		8		
0705	Transmission Auto Shift Control Module	Inspect	0.2					
		Replace		1.1		8, 32		
		Repair		2.1		8, 32		
0705	Transmission Control Module and Brace	Inspect		1.0				
		Replace		12.6		7, 8, 32		
		Repair		13.6		7, 8, 32		
0708	Torque Converter	Replace			7.0	7, 8, 32		
0710	Transmission Assembly	Inspect	0.2					

MAINTENANCE ALLOCATION CHART - (CONTINUED)

(1) GROUP NUMBER	(2) COMPONENT/ASSEMBLY	(3) MAINTENANCE FUNCTION	(4) MAINTENANCE LEVEL				(5) TOOLS AND EQUIPMENT REF CODE	(6) REMARKS CODE
			FIELD		SUSTAINMENT			
			CREW	MAIN-TAI-NER	BE-LOW DEPOT	DEPOT		
			C	F	H	D		
		Service	1.0				E	
		Replace		17.4		7, 8, 32		
		Repair		18.4		7, 8, 22, 32, 40		
		Overhaul				22.0		
0710	Transmission Mounting Crossmember	Inspect		0.5				
		Replace		10.1		8, 32		
0721	Transmission Cooler Hose	Inspect	0.1					
		Replace		10.0		8, 32		
0721	Transmission Fluid and Filter	Inspect	0.2					
		Service		8.6		7, 8, 32		
0721	Transmission Breather	Inspect		2.0				
		Replace		8.2		8		
0721	Transmission Speed Sensors	Inspect		1.0				
		Replace		8.2		8		
		Repair		9.2		8, 22, 40		
0801	Transfer Case Assembly	Inspect	0.1					
		Replace		12.7		7, 8, 32		
		Repair		13.7		7, 8, 32		
		Overhaul				7.0		
0801	Transfer Case Mount and Support	Inspect		0.5				
		Replace		14.0		7, 8		
0801	Transfer Case Armor	Inspect	0.1					
		Replace		1.1		7, 8, 32		
0803	Transfer Case Air Lines	Inspect		0.2				
		Replace		10.0		8		
0803	4-Pack Air Solenoid Module and Support	Inspect		0.2				
		Replace		1.4		8, 32		
		Repair		2.4		4, 8, 22, 32, 40		
0804	Transfer Case Oil Cooler Hose	Inspect	0.1					
		Replace		0.7		7, 8		
0804	Transfer Case Drain/Fill	Service		0.5		7, 8, 32		
0804	Transfer Case Oil Cooler	Inspect		0.1				
		Replace		1.4		8, 32		
0900	Prop Shaft	Inspect	0.1					
		Service	0.2			7, 8	B	
		Replace		8.6		7, 8		

MAINTENANCE ALLOCATION CHART - (CONTINUED)

(1) GROUP NUMBER	(2) COMPONENT/ASSEMBLY	(3) MAINTENANCE FUNCTION	(4) MAINTENANCE LEVEL				(5) TOOLS AND EQUIPMENT REF CODE	(6) REMARKS CODE
			FIELD		SUSTAINMENT			
			CREW	MAIN-TAI-NER	BE-LOW DEPOT	DEPOT		
			C	F	H	D		
0901	Transmission to Transfer Case Prop Shaft	Inspect		0.5				
		Service	0.2			7, 8		
		Replace		9.2		7, 8		
1000	Front Axle Assembly	Inspect	0.2					
		Service		0.5		7, 8, 32		
		Replace		13.9		7, 8, 32		
		Repair		14.9		7, 8, 32		
		Overhaul			16.0			
1000	Front Wheel Hub and Bearing	Inspect		1.0				
		Replace		2.2		7, 8, 32		
1000	Front Axle Assembly Alignment	Service		1.0		7, 8, 32		
1000	Front Axle Breather	Inspect		0.2				
		Replace		0.1		8		
1000	Front Axle Differential Drain/Fill Procedure	Service		0.8		7, 8, 32		
1000	Upper and Lower King Pin Bushing and Axle Shaft Oil Seal	Inspect		0.5				
		Service		0.2		8, 32		
		Replace		11.7		8, 32		
1004	Steering Arm	Inspect		0.5				
		Service		0.2		7, 8, 32		
		Replace		2.9		7, 8, 32		
1004	Steering Knuckle and King Pin	Inspect		0.5				
		Service		0.2		7, 8, 32		
		Replace		10.2		7, 8, 32		
1100	Rear Axle Assembly	Inspect		0.5				
		Service		1.0		7, 8, 32		
		Replace		17.1		7, 8, 32		
		Repair		18.1		7, 8, 32		
		Overhaul			16.0			
1100	Rear Axle Differential Drain/Fill	Service		0.5		7, 8, 32		
1100	Rear Hub Assembly Bearing and Bearing Cup	Inspect		1.5				
		Replace		4.6		8, , 32		
1100	Rear Axle Outer Hub Drain/Fill	Service		0.8		8, 32		

MAINTENANCE ALLOCATION CHART - (CONTINUED)

(1) GROUP NUMBER	(2) COMPONENT/ASSEMBLY	(3) MAINTENANCE FUNCTION	(4) MAINTENANCE LEVEL				(5) TOOLS AND EQUIPMENT REF CODE	(6) REMARKS CODE
			FIELD		SUSTAINMENT			
			CREW	MAIN-TAI-NER	BE-LOW DEPOT	DEPOT		
			C	F	H	D		
1100	Rear Axle Shaft and Gasket	Inspect		1.0				
		Replace		1.4			7, 8, 32	
1202	Front Axle Antilock Braking System (ABS) Tone Ring	Inspect		1.0				
		Replace		2.4			8, 32	
1202	Brake Adjustment Procedure	Adjust		1.3			8	
1202	Front Brake Dust Shield	Inspect		1.0				
		Replace		4.7			8	
1202	Front Brake Shoes	Inspect		1.0				
		Service		1.5				
		Replace		4.2			8	
1202	Front Brake Drum	Inspect		1.0				
		Service		1.5				
		Replace		0.8			8, 32	
1202	Front Brake S-Camshaft	Inspect		1.5				
		Replace		5.2			7, 8	
1202	Front Brake Spider and Spindle Assembly	Inspect		2.0				
		Replace		7.1			7, 8, , 32	
1202	Front Slack Adjuster Assembly	Inspect		0.6				
		Replace		1.8			7, 8	
1202	Rear Antilock Braking System (ABS) Sensor	Inspect		1.5				
		Replace		3.8			8	
		Repair		4.8			8, 22, 40	
1202	Rear Brake Dust Shield	Inspect		0.2				
		Replace		0.1			8	
1202	Rear Brake Shoes	Inspect		1.5				
		Service		1.5				
		Replace		4.0			8	
1202	Rear Brake Drum and Hub Assembly	Inspect		1.5				
		Service		1.5				
		Replace		3.7			7, 8, 32	
1202	Rear Brake S-Camshaft	Inspect		1.5				
		Replace		4.5			7, 8	
1202	Rear Brake Spider Assembly	Inspect		2.0				
		Replace		5.5			7, 8, , 32	
1202	Rear Slack Adjuster Assembly	Inspect		0.6				

MAINTENANCE ALLOCATION CHART - (CONTINUED)

(1) GROUP NUMBER	(2) COMPONENT/ASSEMBLY	(3) MAINTENANCE FUNCTION	(4) MAINTENANCE LEVEL				(5) TOOLS AND EQUIPMENT REF CODE	(6) REMARKS CODE
			FIELD		SUSTAINMENT			
			CREW	MAIN- TAIN- NER	BE- LOW DEPOT	DEPOT		
			C	F	H	D		
		Replace		1.8			7, 8	
1202	Brake S-Camshaft Tube Support Bracket	Inspect		0.1				
		Replace		0.5			7, 8	
1208	Air Reservoir Tank	Inspect		1.0				
		Service	0.2					
		Replace		12.7			7, 8, 32	
1208	Cabin Door Assist System Limit Valve	Inspect	0.1					
		Replace		8.5			8	
1208	Brake Pedal	Inspect		0.2				
		Replace		0.2			7, 8	
1208	Foot Brake Valve	Inspect		1.0				
		Replace		5.6			8	
		Repair		6.6			8	
1208	Tractor Protection Valve	Inspect		1.0				
		Replace		4.6			8	
		Repair		5.6			8	
1208	Upper Air Line Grommet	Inspect		0.2				
		Replace		7.0			8	
1208	Driver Control Module (DCM) Left Air Line Grommet	Inspect		0.2				
		Replace		4.8			8	
1208	Hand Brake Control Valve	Inspect		0.5				
		Replace		1.0			8	
1208	Front Antilock Braking System (ABS) Modulator Valve	Inspect		0.2				
		Replace		0.5			8	
		Repair		1.5			8, 22, 40	
1208	Front Brake Air Hoses	Inspect		0.2				
		Replace		0.1			8	
1208	Spring Brake Modulating Valve	Inspect		0.5				
		Replace		8.8			8	
1208	Air Brake Relay Valve	Inspect		0.1				
		Replace		0.4			8	
1208	Rear Antilock Braking System (ABS) Modulator Valve	Inspect		0.2				
		Replace		0.7			8	

MAINTENANCE ALLOCATION CHART - (CONTINUED)

(1) GROUP NUMBER	(2) COMPONENT/ASSEMBLY	(3) MAINTENANCE FUNCTION	(4) MAINTENANCE LEVEL				(5) TOOLS AND EQUIPMENT REF CODE	(6) REMARKS CODE
			FIELD		SUSTAINMENT			
			CREW	MAIN-TAI-NER	BE-LOW DEPOT	DEPOT		
			C	F	H	D		
		Repair		1.7			8, 22, 40	
1208	Air Hose Quick Connect Fitting	Inspect	0.1					
		Replace		0.1			8	
1208	Air Hose Fitting	Inspect	0.1					
		Replace		0.6			8, 25	
1208	Front Brake Air Chamber	Inspect		0.2				
		Replace		1.7			8, 32	
		Repair		2.7			8, 32	
1208	Rear Brake Air Hoses	Inspect		0.2				
		Replace		0.4			8	
1208	Rear Brake Air Chamber	Inspect		0.2				
		Replace		2.0			8, 32	
		Repair		3.0			8, 32	
1208	Air Dryer	Inspect		0.2				
		Service		0.5				
		Replace		0.4			7, 8, 32	
1208	Air Dryer Bracket	Inspect		0.2				
		Replace		3.2			7, 8	
1208	Air Dryer Desiccant Cartridge	Inspect		0.2				
		Service		0.3				
		Replace		0.2			7, 8	
1208	Pressure Protection Valve	Inspect		0.2				
		Replace		8.3			8	
		Repair		9.3			8	
1208	Air Brake Quick Release Valves	Inspect		0.1				
		Replace		0.2			8	
1208	Air Brake Double Check Valve	Inspect		0.1				
		Replace		11.2			8	
1209	Air Compressor Supply Air Line	Inspect		0.2				
		Replace		0.1			8	
1209	Air Compressor Delivery Air Line	Inspect		1.0				
		Replace		11.7			7, 8	
1209	Air Compressor Governor	Inspect		0.5				
		Replace		0.4			8	
1209	Air Compressor Governor Adjustment Procedure	Adjust		2.0			8	
1209	Air Compressor	Inspect		0.5				
		Replace		14.0			7, 8	

MAINTENANCE ALLOCATION CHART - (CONTINUED)

(1) GROUP NUMBER	(2) COMPONENT/ASSEMBLY	(3) MAINTENANCE FUNCTION	(4) MAINTENANCE LEVEL				(5) TOOLS AND EQUIPMENT REF CODE	(6) REMARKS CODE
			FIELD		SUSTAINMENT			
			CREW	MAIN- TAIN- NER	BE- LOW DEPOT	DEPOT		
			C	F	H	D		
		Repair		15.0			7, 8	
		Overhaul				5.0		
1211	Gladhands	Inspect	0.1					
		Replace		0.3			8	
1211	Trailer Control Valve	Inspect	0.1					
		Replace		2.0			7, 8	
1311	Wheel and Tire Assembly	Inspect	0.1					
		Service	0.1			0.5		
		Replace		0.7			7, 8, 32	
1401	Tie Rod	Inspect		0.5				
		Replace		0.5			7, 8, 32	
1401	Steering Shaft	Inspect		0.5				
		Replace		4.8			8	
1401	Steering Column	Inspect		0.2				
		Replace		7.1			7, 8	
1401	Steering Wheel and Clock Spring	Inspect		0.5				
		Replace		1.8			7, 8	
1401	Pitman Arm	Inspect		0.5				
		Replace		0.6			7, 8, 24, 31, 32	
1401	Steering Drag Link	Inspect		0.5				
		Replace		0.3			7, 8, 32	
1407	Steering Gear	Inspect		0.5				
		Test		0.5				
		Replace		3.3			8, 24, 32	
		Repair		4.3			8, 24, 32	
		Overhaul				3.0		
1407	Bleeding Single Gear	Service		1.0			7, 8,	
1410	Power Steering Pump	Inspect		0.2				
		Replace		10.7			8, 32	
		Repair		11.7			8, 32	
1411	Power Steering Tubing and Hose	Inspect		0.5				
		Replace		0.9			8, 32	
1413	Power Steering Reservoir	Inspect	0.1					
		Service	0.1					
		Replace		0.1			8, 32	
1413	Power Steering Filter	Inspect		0.1				
		Service		0.2				

MAINTENANCE ALLOCATION CHART - (CONTINUED)

(1) GROUP NUMBER	(2) COMPONENT/ASSEMBLY	(3) MAINTENANCE FUNCTION	(4) MAINTENANCE LEVEL				(5) TOOLS AND EQUIPMENT REF CODE	(6) REMARKS CODE
			FIELD		SUSTAINMENT			
			CREW C	MAIN-TAI-NER F	BE-LOW DEPOT H	DEPOT D		
		Replace		0.2			8, 32	
1413	Power Steering Reservoir Drain/Fill Procedure	Service		1.1			7, 8, 32	
1501	Front Bumper	Inspect	0.1					
		Replace		2.0			8	
1501	Winch Remote Control Connector Support	Inspect	0.1					
		Replace		0.4			8	
1501	Front Frame Crossmember and Radiator Support	Inspect		0.2				
		Replace		10.8			8	
1501	Front Frame Crossmember and Support	Inspect		0.5				
		Replace		6.0			8	
1501	Engine Mount Crossmember Assembly	Inspect		0.5				
		Replace		7.3			7, 8	
1501	Rear Frame Crossmember and Support	Inspect		0.5				
		Replace		5.8			8	
1501	Harness Support Bracket	Inspect		0.5				
		Replace		9.8			8	
1503	Rear Towing Eye	Inspect	0.1					
		Service	0.2					
		Replace		4.7			7, 8	
1503	Towing Pintle Hook	Inspect	0.1					
		Service	0.2					
		Replace		4.6			7, 8, 32	
1503	Front Towing Eye	Inspect	0.1					
		Service	0.2					
		Replace		1.2			7, 8	
1601	Front Axle Bumper Stop	Inspect		0.1				
		Replace		0.3			8	
1601	Front Axle Bumper Stop Bracket	Inspect		0.1				
		Replace		0.8			7, 8	
1601	Auxiliary Spring	Inspect		1.0				
		Replace		0.4			7, 8	
1601	Rear Spring Assembly	Inspect	0.1					
		Replace		2.1			7, 8	
1601	Front Spring Shackle	Inspect	0.1					

MAINTENANCE ALLOCATION CHART - (CONTINUED)

(1) GROUP NUMBER	(2) COMPONENT/ASSEMBLY	(3) MAINTENANCE FUNCTION	(4) MAINTENANCE LEVEL				(5) TOOLS AND EQUIPMENT REF CODE	(6) REMARKS CODE
			FIELD		SUSTAINMENT			
			CREW	MAIN-TAI-NER	BE-LOW DEPOT	DEPOT		
			C	F	H	D		
		Service		0.5				
		Replace		9.0		7, 8		
1601	Front Spring Assembly	Inspect	0.1					
		Replace		9.9		7, 8, 32		
1604	Front Shock Absorber	Inspect	0.1					
		Replace		0.6		7, 8		
1604	Front Shock Absorber Lower Mounting Bracket	Inspect		0.1				
		Replace		1.6		7, 8, 32		
1604	Front Shock Absorber Upper Mounting Bracket	Inspect		0.1				
		Replace		1.0		7, 8		
1801	Cabin	Inspect	0.2					
		Replace				16.0		
1801	Instrument Panel (IP) Storage Bin	Inspect	0.1					
		Replace		1.1		8		
1801	Cross-Vehicle Equipment Bracket	Inspect	0.1					
		Replace		4.9		7, 8		
1801	Steering Column Covers	Inspect	0.1					
		Replace		1.1		8, 32		
1801	Driver Control Mounting (DCM) Bracket	Inspect		0.2				
		Replace		11.7		8		
1801	Armor Grille	Inspect	0.1					
		Replace		2.4		7, 8, 30, 32		
1801	Armor Grille Support and Armor Grille Support Bracket	Inspect		0.5				
		Replace		5.2		8		
1801	Hood/Fender Latch	Inspect	0.1					
		Replace		0.1		8		
1801	Hood Hinge Assembly	Inspect	0.1					
		Replace		0.8		7, 8		
1801	Hood Grille Air Intake	Inspect	0.1					
		Replace		0.1		8		
1801	Hood Grille Surround Assembly	Inspect	0.1					
		Replace		0.8		8		
1801	Hood Safety Cable Assembly	Inspect	0.1					

MAINTENANCE ALLOCATION CHART - (CONTINUED)

(1) GROUP NUMBER	(2) COMPONENT/ASSEMBLY	(3) MAINTENANCE FUNCTION	(4) MAINTENANCE LEVEL				(5) TOOLS AND EQUIPMENT REF CODE	(6) REMARKS CODE
			FIELD		SUSTAINMENT			
			CREW C	MAIN-TAI-NER F	BE-LOW DEPOT H	DEPOT D		
		Replace		0.2			8	
1801	Hood Torsion Assist Bar	Inspect	0.1					
		Replace		0.1			8	
1801	Hood Assembly	Inspect	0.1					
		Replace		2.1			7, 8, 32	
1801	Hood Mirror	Inspect	0.1					
		Replace		0.6			8, 32	
1801	Instrument Panel (IP)	Inspect	0.1					
		Replace		4.3			7, 8	
1801	Instrument Panel (IP) Cluster Closeout	Inspect	0.1					
		Replace		2.0			8	
1801	Instrument Panel (IP) Center Closeout	Inspect	0.1					
		Replace		0.7			8	
1801	Instrument Panel (IP) Right Side Closeout	Inspect	0.1					
		Replace		0.2			8	
1801	Instrument Panel (IP) Center Trim Panel	Inspect	0.1					
		Replace		0.5			8, 32	
1801	Nuclear, Biological, and Chemical (NBC) Gauge	Inspect		0.1				
		Replace		1.9			8	
		Repair		2.9			8	
1801	Cabin Roof Molding	Inspect	0.1					
		Replace		1.0			8	
1801	Roof Armor Front Panel	Inspect	0.1					
		Replace		0.2			7, 8	
1801	Roof Armor Front Spoiler	Inspect	0.1					
		Replace		3.4			7, 8	
1801	Roof Armor Middle Front Panel	Inspect	0.1					
		Replace		3.0			7, 8	
1801	Roof Armor Middle Rear Panel	Inspect	0.1					
		Replace		3.0			7, 8	
1801	Roof Armor Rear Spoiler	Inspect	0.1					
		Replace		0.2			7, 8, 30	
1801	Roof Armor Rear Panel	Inspect	0.1					
		Replace		0.2			7, 8	
1801	Weapon (Sliding) Hatch (Gunner Hatch)	Inspect	0.1					
		Service		0.1				

MAINTENANCE ALLOCATION CHART - (CONTINUED)

(1) GROUP NUMBER	(2) COMPONENT/ASSEMBLY	(3) MAINTENANCE FUNCTION	(4) MAINTENANCE LEVEL				(5) TOOLS AND EQUIPMENT REF CODE	(6) REMARKS CODE
			FIELD		SUSTAINMENT			
			CREW	MAIN- TAI- NER	BE- LOW DEPOT	DEPOT		
			C	F	H	D		
		Replace		3.5			7, 8, 30, 32	
1801	Weapon (Sliding) Hatch (Gunner Hatch) Inner Lock	Inspect	0.1					
		Replace		0.3			8	
1801	Weapon (Sliding) Hatch (Gunner Hatch) Seal	Inspect	0.1					
		Replace		0.2			7, 8	
1801	Cabin Emergency Hatch and Hinge	Inspect	0.1					
		Replace		0.8			7, 8, 30, 32	
1801	Cabin Emergency Hatch Handle/Lock	Inspect	0.1					
		Replace		0.3			8	
1801	Cabin Emergency Hatch Seal	Inspect	0.1					
		Replace		0.5			3, 7, 8	
1801	Hulls with Gun Port	Inspect	0.1					
		Replace		0.5			8, 32	
1801	Left Engine Armor Plate	Inspect	0.1					
		Replace		0.3			7, 8, 32	
1801	Left Engine Armor Plate Bracket	Inspect	0.1					
		Replace		1.0			8	
1801	Right Engine Armor Plate	Inspect	0.1					
		Replace		1.2			7, 8, 32	
1801	Right Engine Armor Plate Bracket	Inspect	0.1					
		Replace		2.0			7, 8, 32	
1801	Inner Wheel Deflector Armor Plate	Inspect	0.1					
		Replace		0.8			8, 32	
1801	Left Inner Wheel Deflector Bracket	Inspect	0.1					
		Replace		13.1			8, 32	
1801	Right Inner Wheel Deflector Bracket	Inspect	0.1					
		Replace		14.5			8	
1801	Exterior Battery Box Armor Door	Inspect	0.1					
		Replace		0.3			8	
1801	Exterior Fuel Tank Armor Door	Inspect	0.1					

MAINTENANCE ALLOCATION CHART - (CONTINUED)

(1) GROUP NUMBER	(2) COMPONENT/ASSEMBLY	(3) MAINTENANCE FUNCTION	(4) MAINTENANCE LEVEL				(5) TOOLS AND EQUIPMENT REF CODE	(6) REMARKS CODE
			FIELD		SUSTAINMENT			
			CREW	MAIN-TAI-NER	BE-LOW DEPOT	DEPOT		
			C	F	H	D		
		Replace		0.6			8	
1801	Belly Armor	Inspect	0.1					
		Replace		8.0			3, 7, 8, 32	
1801	Cabin Door	Inspect	0.1					
		Replace		5.1			7, 8, 30, 32	
1801	Securing Cabin Door for Service	Service		0.2			3, 8, 30, 32	
1801	Door Armor Panel	Inspect	0.1					
		Replace		1.8			7, 8, 30, 32	
1801	Door Window Riot Guard	Inspect	0.1					
		Replace		2.0			8	
1801	Upper Cabin Door Lock, Spacer, and Bracket	Inspect	0.1					
		Replace		0.9			8	
1801	Lower Cabin Door Lock, Spacer, and Bracket	Inspect	0.1					
		Replace		0.9			8	
1801	Cabin Door Striker and Cabin Door Check Stop Assemblies	Inspect	0.1					
		Replace		0.4			8, 32	
1801	Cabin Door Seal	Inspect	0.1					
		Replace		0.5			7, 8	
1801	Cabin Door Linkage Inspection and Adjustment Procedure (Lower Combat Door Lock-Type)	Inspect		0.4				
		Adjust		1.0			8, 32	
1801	Cabin Door Linkage Inspection and Adjustment Procedure (Upper Combat Door Lock-Type)	Inspect		0.4				
		Adjust		1.2			8, 32	
1801	Dual-Pneumatic Door Actuator	Inspect		1.0				
		Replace		3.3			8	
		Repair		4.3			8	
1801	Cabin Door Assist System Actuator Air Line Tubing	Inspect	0.1					
		Replace		1.2			8	
1801	Left Door Air Supply Line	Inspect	0.1					
		Replace		1.2			8	
1801	Right Cabin Door Assist System Supply Air Line Tubing	Inspect	0.1					

MAINTENANCE ALLOCATION CHART - (CONTINUED)

(1) GROUP NUMBER	(2) COMPONENT/ASSEMBLY	(3) MAINTENANCE FUNCTION	(4) MAINTENANCE LEVEL				(5) TOOLS AND EQUIPMENT REF CODE	(6) REMARKS CODE
			FIELD		SUSTAINMENT			
			CREW	MAIN-TAI-NER	BE-LOW DEPOT	DEPOT		
			C	F	H	D		
		Replace		1.2			8	
1801	Cabin Door Assist System Supply Pass-Through Air Line Tubing	Inspect	0.1					
		Replace		4.9			8	
1801	Cabin Door Assist System Supply Air Line Tubing	Inspect	0.1					
		Replace		9.5			8	
1801	Cabin Door Exterior Handle Assembly (Single and Dual Cylinder)	Inspect	0.1					
		Replace		4.1			8, 32	
1801	Cabin Door Interior Handle Assembly (Single-Piston, Lower Combat Door Lock-Type)	Inspect	0.1					
		Replace		2.5			7, 8, 32	
1801	Cabin Door Interior Handle Assembly (Dual-Piston, Upper Combat Door Lock-Type)	Inspect	0.1					
		Replace		2.2			7, 8, 32	
1801	Cabin Door Trim Panel (One-Piece, Lower Combat Door Lock-Type)	Inspect	0.1					
		Replace		0.5			8	
1801	Cabin Door Trim Panel (Two-Piece, Upper Combat Door Lock-Type)	Inspect	0.1					
		Replace		0.7			8	
1801	Cabin Door Combat Lock Assembly	Inspect	0.1					
		Replace		1.7			8	
1801	Exterior Body Armor Right Front Panel	Inspect	0.1					
		Replace		0.7			8	
1801	Exterior Body Armor Middle Rear Panel	Inspect	0.1					
		Replace		0.4			7, 8	
1801	Exterior Body Armor Rear Panel	Inspect	0.1					
		Replace		0.2			7, 8	
1801	Exterior Body Armor Riot Guard	Inspect	0.1					
		Replace		0.2			8	

MAINTENANCE ALLOCATION CHART - (CONTINUED)

(1) GROUP NUMBER	(2) COMPONENT/ASSEMBLY	(3) MAINTENANCE FUNCTION	(4) MAINTENANCE LEVEL				(5) TOOLS AND EQUIPMENT REF CODE	(6) REMARKS CODE
			FIELD		SUSTAINMENT			
			CREW	MAIN-TAI-NER	BE-LOW DEPOT	DEPOT		
			C	F	H	D		
1801	Exterior Body Armor Left Front Panel	Inspect	0.1					
		Replace		0.4			7, 8, 30, 32	
1801	Exterior Body Armor Left Middle Front Panel	Inspect	0.1					
		Replace		0.4			7, 8	
1801	Exterior Body Armor Right Middle Front Panel	Inspect	0.1					
		Replace		0.6			7, 8	
1801	Rear Door/Ramp Seal	Inspect	0.1					
		Replace		0.3			7, 8	
1801	Body Armor Rear Wall Riot Guard and Bracket	Inspect	0.1					
		Replace		0.7			8	
1801	Rear Wall Overlap	Inspect	0.1					
		Replace		0.7			8	
1801	Rear Door/Ramp	Inspect	0.2					
		Replace		1.9			7, 8, 30, 32	
1801	Bottom Ramp Step	Inspect	0.1					
		Replace		0.1			8	
1801	Rear Door/Ramp Lock Assembly	Inspect	0.2					
		Replace		1.0			8, 32	
1801	A-Pillar Cover Trim	Inspect	0.1					
		Replace		0.4			8	
1801	A-Pillar Assist Handle	Inspect	0.1					
		Replace		0.2			8	
1801	Side Cowl Body Armor Panel	Inspect	0.1					
		Replace		0.8			7, 8	
1801	Windshield Armor	Inspect	0.1					
		Replace		4.2			8	
1801	Driver Control Mounting (DCM) Bracket Assembly Exterior Armor (With Front Access Panel)	Inspect	0.1					
		Replace		4.2			7, 8, 32	
1801	Driver Control Mounting (DCM) Bracket Assembly Exterior Armor (Without Front Access Panel)	Inspect	0.1					
		Replace		4.2			7, 8, 32	
1801	Driver Control Mounting (DCM) Bracket Assembly Interior Armor	Inspect	0.1					
		Replace		4.4			7, 8, 32	

MAINTENANCE ALLOCATION CHART - (CONTINUED)

(1) GROUP NUMBER	(2) COMPONENT/ASSEMBLY	(3) MAINTENANCE FUNCTION	(4) MAINTENANCE LEVEL				(5) TOOLS AND EQUIPMENT REF CODE	(6) REMARKS CODE
			FIELD		SUSTAINMENT			
			CREW	MAIN-TAI-NER	BE-LOW DEPOT	DEPOT		
			C	F	H	D		
1801	Engine Cover	Inspect	0.1					
		Replace		3.3		8		
1801	Cowl Panel Drain Tube	Inspect	0.1					
		Replace		0.1		8		
1801	Motor Baffle	Inspect	0.1					
		Replace		5.8		8		
1802	Rear Window Armor Glass	Inspect	0.1					
		Replace		1.7		8		
1802	Door Window Armor Glass	Inspect	0.1					
		Replace		2.9		7, 8, 30, 32		
1802	Cabin Window Armor Glass	Inspect	0.1					
		Replace		2.3		7, 8, 30, 32		
1802	Windshield Armor Glass	Inspect	0.1					
		Replace		9.2		7, 8, 30, 32		
1802	Step and Brackets	Inspect	0.1					
		Replace		0.7		8		
1802	Fender and Reinforcement	Inspect	0.1					
		Replace		0.6		7, 8		
1805	Floor Panel (Front)	Inspect	0.1					
		Replace		15.2		8		
1805	Floor Panel (Front Center)	Inspect	0.1					
		Replace		2.9		8		
1805	Center Floor Panel	Inspect	0.1					
		Replace		2.3		8		
1805	Rear Center Floor Panel	Inspect	0.1					
		Replace		1.9		7, 8, 30, 32		
1805	Rear Floor Panel	Inspect	0.1					
		Replace		7.0		8		
1806	Driver Seat	Inspect	0.1					
		Replace		1.0		8		
1806	Seat Belt	Inspect	0.1					
		Replace		0.4		7, 8		
1806	Right Floor Seat Bracket	Inspect	0.1					
		Replace		1.7		8		
1806	Crew and Front Passenger Seat	Inspect	0.1					

MAINTENANCE ALLOCATION CHART - (CONTINUED)

(1) GROUP NUMBER	(2) COMPONENT/ASSEMBLY	(3) MAINTENANCE FUNCTION	(4) MAINTENANCE LEVEL				(5) TOOLS AND EQUIPMENT REF CODE	(6) REMARKS CODE
			FIELD		SUSTAINMENT			
			CREW	MAIN-TAI-NER	BE-LOW DEPOT	DEPOT		
		Replace		0.3			8	
1808	Communications Rack		0.1					
		Replace		1.8			8, 32	
1808	Gunner Platform/Stand	Inspect	0.1					
		Replace		0.9			8	
1808	Gunner Restraint Assembly	Inspect	0.1					
		Replace		0.4			8	
1808	Rear Communication Rack	Inspect	0.1					
		Replace		0.7			3, 8	
1808	Right Side Forward Stowage Box	Inspect	0.1					
		Replace		4.3			8	
1808	Air Conditioning (A/C) Condenser Panel	Inspect	0.1					
		Replace		0.4			8	
1808	Right Side Rear Stowage Box	Inspect	0.1					
		Replace		0.6			8	
1808	Left Side Forward Stowage Box	Inspect	0.1					
		Replace		2.1			8	
1808	Right Rear Stowage Box Latch	Inspect	0.1					
		Replace		0.2			7, 8	
1808	Left Rear Stowage Box	Inspect	0.1					
		Replace		0.9			8	
2001	Winch Cable	Inspect	0.1					
		Replace		1.0			7, 8	
2001	Winch Assembly	Inspect	0.2					
		Replace		2.8			7, 8, 30, 32	
		Overhaul				3.0		
2202	Litter Arm Storage Bracket	Inspect	0.1					
		Replace		0.2			8	
2202	Front Litter Arm Mount Plate and Arm Support	Inspect	0.1					
		Replace		0.5			8	
2202	Rear Litter Arm Mount Plate and Arm Support	Inspect	0.1					
		Replace		0.2			8	
2202	Door Mounted Mirror	Inspect	0.1					
		Replace		0.1			8, 32	
2202	Wiper Cowl Panel	Inspect	0.1					

MAINTENANCE ALLOCATION CHART - (CONTINUED)

(1) GROUP NUMBER	(2) COMPONENT/ASSEMBLY	(3) MAINTENANCE FUNCTION	(4) MAINTENANCE LEVEL				(5) TOOLS AND EQUIPMENT REF CODE	(6) REMARKS CODE
			FIELD		SUSTAINMENT			
			CREW	MAIN- TAI- NER	BE- LOW DEPOT	DEPOT		
			C	F	H	D		
		Replace		1.7			7, 8, 32	
2202	Windshield Wiper Motor, Transmission, Bracket, and Linkage Assembly	Inspect	0.1					
		Replace		2.5			7, 8	
		Repair		3.5			7, 8, 40	
2202	Windshield Wiper Arm and Blade Assembly	Inspect	0.1					
		Replace		0.2			7, 8	
2202	Windshield Washer Reservoir and Pump Motor Assembly	Inspect	0.1					
		Replace		0.4			8, 32	
		Repair		1.4			8, 13, 32, 40	
2202	Windshield Washer Hose Assembly	Inspect	0.1					
		Replace		1.8			8	
2202	Windshield Washer Reservoir Bracket	Inspect	0.1					
		Replace		1.3			8, 32	
2202	Windshield Wiper Motor Harness	Inspect	0.1					
		Replace		1.9			8	
		Repair		2.9			8	
2401	Rear Door/Ramp Hydraulic Pump Cover (Push-Type Operation)	Inspect		0.1				
		Replace		0.2			8	
2401	Rear Door/Ramp Hydraulic Pump Cover (Pull-Type Operation)	Inspect		0.1				
		Replace		0.3			8	
2401	Rear Door/Ramp Hydraulic Pump (Push-Type Operation)	Inspect		0.1				
		Service		0.5				
		Replace		1.4			8, 32	
		Repair		2.4			8, 32, 40	
2401	Rear Door/Ramp Hydraulic Pump (Pull-Type Operation)	Inspect		0.1				
		Service		0.5				
		Replace		3.4			8	
		Repair		4.4			8, 40	

MAINTENANCE ALLOCATION CHART - (CONTINUED)

(1) GROUP NUMBER	(2) COMPONENT/ASSEMBLY	(3) MAINTENANCE FUNCTION	(4) MAINTENANCE LEVEL				(5) TOOLS AND EQUIPMENT REF CODE	(6) REMARKS CODE
			FIELD		SUSTAINMENT			
			CREW	MAIN-TAI-NER	BE-LOW DEPOT	DEPOT		
			C	F	H	D		
2401	Rear Door/Ramp Hydraulic Hand Pump (Push-Type Operation)	Inspect		0.1				
		Service		0.5				
		Replace		0.5		8, 32		
		Repair		1.5		8, 32		
2401	Rear Door/Ramp Hydraulic Power Unit Manifold and Module (Pull-Type Operation)	Inspect		0.1				
		Service		0.5				
		Replace		2.2		8, 32		
2401	Rear Door/Ramp Hydraulic Cylinder (Push-Type Operation)	Inspect		0.1				
		Replace		0.6		7, 8, 32		
		Repair		1.6		7, 8, 32		
2401	Rear Door/Ramp Hydraulic Cylinder (Pull-Type Operation)	Inspect		0.1				
		Replace		0.7		7, 8, 32		
2401	Rear Door/Ramp Gas Spring	Inspect		0.1				
		Replace		1.2		8, 32		
2401	Rear Door/Ramp Hydraulic Reservoir Fluid Fill Procedure (Pull-Type Operation)	Service		0.5		7, 8		
2401	Rear Door/Ramp Hydraulic Hoses (Push-Type Operation)	Inspect		0.1				
		Replace		0.5		7, 8, 32		
2401	Rear Door/Ramp Hydraulic Hoses (Pull-Type Operation)	Inspect		0.1				
		Replace		0.6		7, 8, 32		
3401	Outside Gunner Protection Riser	Inspect	0.1					
		Replace		2.8		7, 8, 30, 32		
3401	Outside Gunner Protection Armor	Inspect	0.1					
		Replace		0.2		8		
3401	Gun Turret Platform	Inspect	0.1					
		Replace		1.9		3, 7, 8, 30, 32		
3401	Turret Mounting Plate	Inspect	0.1					
		Replace		0.9		7, 8, 30, 32		
3402	Rifle Rack	Inspect	0.1					
		Replace		0.3		8		

MAINTENANCE ALLOCATION CHART - (CONTINUED)

(1) GROUP NUMBER	(2) COMPONENT/ASSEMBLY	(3) MAINTENANCE FUNCTION	(4) MAINTENANCE LEVEL				(5) TOOLS AND EQUIPMENT REF CODE	(6) REMARKS CODE
			FIELD		SUSTAINMENT			
			CREW	MAIN- TAIN- NER	BE- LOW DEPOT	DEPOT		
			C	F	H	D		
5200	Heating Ventilating and Air Conditioning (HVAC) Service/Recharge	Service		1.0			8, 26, 27	G
5200	Heating Ventilating and Air Conditioning (HVAC) Compressor	Inspect		0.5				
		Replace		2.7			8, 27, 32	
		Repair		3.7			8, 32	
5217	Heating Ventilating and Air Conditioning (HVAC) Evaporator Inlet Hose	Inspect		0.5				
		Replace		1.7			8, 27, 32	
5217	Heating Ventilating and Air Conditioning (HVAC) Evaporator Outlet Hose	Inspect		0.5				
		Replace		4.4			8, 27, 32	
5217	Heating Ventilating and Air Conditioning (HVAC) Filter Outlet Hose	Inspect		0.5				
		Replace		1.2			7, 8	
5217	Heating Ventilating and Air Conditioning (HVAC) Compressor Suction Hose	Inspect		0.5				
		Replace		2.9			7, 8	
5217	Heating Ventilating and Air Conditioning (HVAC) Left-Side Condenser Inlet Hose	Inspect		0.5				
		Replace		5.2			7, 8	
5217	Heating Ventilating and Air Conditioning (HVAC) Right-Side Condenser Inlet Hose	Inspect		1.0				
		Replace		4.8			7, 8	
5217	Heating Ventilating and Air Conditioning (HVAC) Left-Side Condenser Outlet Hose	Inspect		0.5				
		Replace		5.0			7, 8	
5217	Heating Ventilating and Air Conditioning (HVAC) Right-Side Condenser Outlet Hose	Inspect		0.5				
		Replace		3.6			7, 8	

MAINTENANCE ALLOCATION CHART - (CONTINUED)

(1) GROUP NUMBER	(2) COMPONENT/ASSEMBLY	(3) MAINTENANCE FUNCTION	(4) MAINTENANCE LEVEL				(5) TOOLS AND EQUIPMENT REF CODE	(6) REMARKS CODE
			FIELD		SUSTAINMENT			
			CREW	MAIN-TAI-NER	BE-LOW DEPOT	DEPOT		
			C	F	H	D		
5217	Heating Ventilating and Air Conditioning (HVAC) Compressor Discharge Hose	Inspect		0.5				
		Replace		2.1			7, 8	
5217	Heating Ventilating and Air Conditioning (HVAC) Service Port/Schrader Valve	Inspect		0.5				
		Replace		1.5			7, 27	
5217	Heating Ventilating and Air Conditioning (HVAC) Water Drainage Hose	Inspect		0.1				
		Replace		0.1			8	
5217	Heating Ventilating and Air Conditioning (HVAC) Fresh Air Inlet Tube	Inspect		0.3				
		Replace		0.2			8	
5217	Nuclear, Biological, and Chemical (NBC) Dust Tube	Inspect		0.5				
		Replace		0.8			8	
5221	Heating Ventilating and Air Conditioning (HVAC) Refrigerant Filter	Inspect		0.1				
		Service		0.5				
		Replace		2.8			7, 8	
5243	Heating Ventilating and Air Conditioning (HVAC) Condenser	Inspect		0.2				
		Replace		1.6			8	
5243	Heating Ventilating and Air Conditioning (HVAC) Condenser Fan Assembly	Inspect		1.0				
		Replace		1.4			8	
		Repair		2.4			8, 40	
5247	Engine Water Outlet Pipe and Elbow	Inspect	0.2					
		Replace		6.1			8, 32	
5247	Heating Ventilating and Air Conditioning (HVAC) 3-Way Valve Coolant Outlet Hose	Inspect		9.2				
		Replace		10.2			8, 32	
5247	Heating Ventilating and Air Conditioning (HVAC) 3-Way Valve and Bracket	Inspect		1.0				
		Replace		2.0			8, 32	
		Repair		3.0			8, 32, 40	

MAINTENANCE ALLOCATION CHART - (CONTINUED)

(1) GROUP NUMBER	(2) COMPONENT/ASSEMBLY	(3) MAINTENANCE FUNCTION	(4) MAINTENANCE LEVEL				(5) TOOLS AND EQUIPMENT REF CODE	(6) REMARKS CODE
			FIELD		SUSTAINMENT			
			CREW	MAIN-TAI-NER	BE-LOW DEPOT	DEPOT		
			C	F	H	D		
5247	Heating Ventilating and Air Conditioning (HVAC) Cabin Heater Hose	Inspect		0.2				
		Replace		1.4			8, 32	
5247	Heating Ventilating and Air Conditioning (HVAC) Fuel-Fired Heater Coolant Outlet Hose	Inspect		1.0				
		Replace		3.8			8, 32	
5247	Heating Ventilating and Air Conditioning (HVAC) 3-Way Valve Coolant Inlet Hose	Inspect		1.0				
		Replace		1.5			8, 32	
5247	Heating Ventilating and Air Conditioning (HVAC) Fuel-Fired Heater Coolant Inlet Hose	Inspect		1.0				
		Replace		3.4			8, 32	
5247	Fuel-Fired Heater	Inspect	0.1					
		Replace		1.3			8, 32	
		Repair		2.3			8, 32, 40	
5247	Fuel-Fired Heater Fuel Pump and Fuel Line	Inspect	0.1					
		Replace		8.4			8, 32	
		Repair		9.4			8, 32, 40	
5247	Fuel-Fired Heater and Fuel-Fired Fuel Pump Harness	Inspect	0.1					
		Replace		8.7			8, 32	
		Repair		9.7			8, 32, 40	
5247	Fuel Fired Heater Timer Control	Inspect	0.1					
		Replace		1.3			8	
		Repair		2.3			8	
7639	Fire Suppression System (FSS) Disable and Enable	Service	0.1				8	
7639	Fire Suppression System (FSS) Control Unit	Inspect	0.1					
		Replace		0.2			8	
		Repair		1.2			8	
7639	Fire Suppression System (FSS) Control Unit Bracket	Inspect	0.1					
		Replace		0.3			8	

MAINTENANCE ALLOCATION CHART - (CONTINUED)

(1) GROUP NUMBER	(2) COMPONENT/ASSEMBLY	(3) MAINTENANCE FUNCTION	(4) MAINTENANCE LEVEL				(5) TOOLS AND EQUIPMENT REF CODE	(6) REMARKS CODE
			FIELD		SUSTAINMENT			
			CREW	MAIN-TAI-NER	BE-LOW DEPOT	DEPOT		
			C	F	H	D		
7639	Fire Suppression System (FSS) Cabin Harness	Inspect	0.1					
		Replace		1.8		8		
		Repair		2.8		8, 40		
7639	Fire Suppression System (FSS) Chassis Harness	Inspect	0.1					
		Replace		11.0		8		
		Repair		12.0		8, 40		
7639	Fire Suppression System (FSS) Engine Compartment Sensor	Inspect	0.1					
		Replace		0.6		8		
		Repair		1.6		8, 40		
7639	Fire Suppression System (FSS) Cabin Sensor	Inspect	0.1					
		Replace		4.1		8		
		Repair		5.1		8, 40		
7639	Fire Suppression System (FSS) Fuel Tank Cylinder	Inspect		0.1				
		Replace		0.3		8		
7639	Fire Suppression System (FSS) Fuel Tank Dispersion Unit and Pipe	Inspect		0.1				
		Replace		8.6		8		
7639	Fire Suppression System (FSS) Cabin Cylinder	Inspect	0.1					
		Replace		0.4		8		
7639	Fire Suppression System (FSS) Cabin/Crew Dispersion Unit and Pipe	Inspect		0.1				
		Replace		0.3		8		
7639	Fire Suppression System (FSS) Tire Cylinder	Inspect		0.1				
		Replace		1.2		8		
7639	Fire Suppression System (FSS) Front Tire Dispersion Unit and Pipe	Inspect		0.1				
		Replace		0.3		8		
7639	Fire Suppression System (FSS) Rear Tire Dispersion Unit and Pipe	Inspect		0.5				
		Replace		0.6		8		
7639	Fire Suppression System (FSS) Engine Cylinder	Inspect		0.1				
		Replace		0.3		8		

MAINTENANCE ALLOCATION CHART - (CONTINUED)

(1) GROUP NUMBER	(2) COMPONENT/ASSEMBLY	(3) MAINTENANCE FUNCTION	(4) MAINTENANCE LEVEL				(5) TOOLS AND EQUIPMENT REF CODE	(6) REMARKS CODE
			FIELD		SUSTAINMENT			
			CREW	MAIN- TAI- NER	BE- LOW DEPOT	DEPOT		
			C	F	H	D		
7639	Fire Suppression System (FSS) Engine Dispersion Unit and Pipe	Inspect		0.1				
		Replace		0.2		8		
9110	Heating Ventilating and Air Conditioning (HVAC)/Life Support System (LSS) Main Air Duct	Inspect		0.1				
		Replace		4.1		8		
9110	Heating Ventilating and Air Conditioning (HVAC)/Life Support System (LSS) Air Duct Louver	Inspect		0.1				
		Replace		0.3		8		
9110	Heating Ventilating and Air Conditioning (HVAC)/Life Support System (LSS) Defogging Air Duct	Inspect		0.1				
		Replace		0.5		8		
9110	Heating Ventilating and Air Conditioning (HVAC)/Life Support System (LSS) Diffuser Air Duct	Inspect		0.1				
		Replace		0.7		8		
9110	Heating Ventilating and Air Conditioning (HVAC)/Life Support System (LSS) Fresh Air Inlet Flange	Inspect		0.3				
		Replace		3.8		8		
9110	Heating Ventilating and Air Conditioning (HVAC)/Life Support System (LSS) Overpressure Relief Valve	Inspect		0.1				
		Replace		0.8		8		
		Repair		1.8		8		
9111	Heating Ventilating and Air Conditioning (HVAC) Receiver/Drier	Inspect		0.2				
		Replace		2.3		7, 8, 27		
9111	Heating Ventilating and Air Conditioning (HVAC) Main Evaporator Assembly	Inspect		1.0				

MAINTENANCE ALLOCATION CHART - (CONTINUED)

(1) GROUP NUMBER	(2) COMPONENT/ASSEMBLY	(3) MAINTENANCE FUNCTION	(4) MAINTENANCE LEVEL				(5) TOOLS AND EQUIPMENT REF CODE	(6) REMARKS CODE
			FIELD		SUSTAINMENT			
			CREW	MAIN-TAI-NER	BE-LOW DEPOT	DEPOT		
			C	F	H	D		
		Replace		16.9			7, 8	
9111	Heating Ventilating and Air Conditioning (HVAC) Heater Radiator	Inspect		1.0				
		Replace		16.6			8, 27	
9111	Heating Ventilating and Air Conditioning (HVAC)/Life Support System (LSS) Box	Inspect		0.5				
		Replace		8.6			8, 32	
		Repair		9.6				
9111	Nuclear, Biological, and Chemical (NBC) Filter	Inspect	0.1					
		Service		1.0				
		Replace		1.0			8	H
9111	Nuclear, Biological, and Chemical (NBC) Filter Cover and Housing	Inspect		0.5				
		Replace		1.7			8	
9111	Nuclear, Biological, and Chemical (NBC) Particle Separator Filter	Inspect		0.5				
		Service		1.0				
		Replace		2.1			8	H
9111	Heating Ventilating and Air Conditioning (HVAC)/Life Support System (LSS) Main Blower Motor and Support	Inspect		0.5				
		Replace		2.7			8	
		Repair		3.7			8	
9111	Heating Ventilating and Air Conditioning (HVAC)/Life Support System (LSS) Upper Blower	Inspect		0.5				
		Replace		2.5			8, 27	
		Repair		3.5			8, 27	
9111	Heating Ventilating and Air Conditioning (HVAC)/Life Support System (LSS) Upper Panel	Inspect		0.5				
		Replace		0.2			8	
9112	Heating Ventilating and Air Conditioning (HVAC) Recirculated Air (RA) Temperature Sensor	Inspect		0.2				
		Replace		0.5			8	

MAINTENANCE ALLOCATION CHART - (CONTINUED)

(1) GROUP NUMBER	(2) COMPONENT/ASSEMBLY	(3) MAINTENANCE FUNCTION	(4) MAINTENANCE LEVEL				(5) TOOLS AND EQUIPMENT REF CODE	(6) REMARKS CODE
			FIELD		SUSTAINMENT			
			CREW	MAIN- TAIN- NER	BE- LOW DEPOT	DEPOT		
			C	F	H	D		
		Repair		1.5			8, 27	
9112	Climate Control Unit (CCU) Box	Inspect		0.2				
		Replace		0.6			8	
9112	Heating Ventilating and Air Conditioning (HVAC)/Life Support System (LSS) Operator Panel	Inspect	0.1					
		Replace		0.3			8	
		Repair		1.3			8, 27, 40	
9112	Heating Ventilating and Air Conditioning (HVAC) Low Pressure Switch	Inspect		0.5				
		Replace		1.3			7, 8	
		Repair		2.3			7, 8, 40	
9112	Heating Ventilating and Air Conditioning (HVAC) Left Condenser Control Wiring Harness	Inspect		0.2				
		Replace		1.9			8	
		Repair		2.9			8	
9112	Heating Ventilating and Air Conditioning (HVAC) Right Condenser Control Wiring Harness	Inspect		0.1				
		Replace		1.9			8	
		Repair		2.9			8	
9112	Heating Ventilating and Air Conditioning (HVAC)/Life Support System (LSS) Engine Wiring Harness	Inspect		0.1				
		Replace		0.6			8	
		Repair		1.6			8, 13, 40	
9112	Heating Ventilating and Air Conditioning (HVAC)/Life Support System (LSS) Control Input Wiring Harness	Inspect		0.1				
		Replace		0.7			8	
		Repair		1.7			8, 40	
9112	Heating Ventilating and Air Conditioning (HVAC)/Life Support System (LSS) Control 2 Wiring Harness	Inspect		0.1				

MAINTENANCE ALLOCATION CHART - (CONTINUED)

(1) GROUP NUMBER	(2) COMPONENT/ASSEMBLY	(3) MAINTENANCE FUNCTION	(4) MAINTENANCE LEVEL				(5) TOOLS AND EQUIPMENT REF CODE	(6) REMARKS CODE
			FIELD		SUSTAINMENT			
			CREW	MAIN-TAI-NER	BE-LOW DEPOT	DEPOT		
			C	F	H	D		
		Replace		0.9			8	
		Repair		1.9			8, 40	
9112	Heating Ventilating and Air Conditioning (HVAC)/Life Support System (LSS) Control Power Wiring Harness	Inspect		0.1				
		Replace		2.5			8	
		Repair		3.5			8, 40	
9112	Heating Ventilating and Air Conditioning (HVAC)/Life Support System (LSS) Main Blower Motor Wiring Harness	Inspect		0.1				
		Replace		2.4			8	
		Repair		3.4			8, 40	
9112	Heating Ventilating and Air Conditioning (HVAC)/Life Support System (LSS) Upper Blower Wiring Harness	Inspect		0.1				
		Replace		0.4			8	
		Repair		1.4			8, 40	
9112	Heating Ventilating and Air Conditioning (HVAC)/Life Support System (LSS) Control Wiring Harness	Inspect		0.1				
		Replace		0.7			8	
		Repair		1.7			8, 40	

Table 2. Tools and Test Equipment.

TOOLS OR TEST EQUIPMENT REF CODE	MAINTENANCE LEVEL	NOMENCLATURE	NATIONAL STOCK NUMBER	TOOL NUMBER
1	ASB	Adapter, crankcase pressure test	4940-01-573-0113	ZTSE4039
2	ASB	Adapter, ICP	4920-01-568-6355	ZTSE4359
3	ASB	Belly Armor Removal/Installer Kit	4940-01-573-0094	ZTSE4903
4	ASB	Box, breakout, Electronic System Controller (ESC)	4940-01-573-0141	ZTSE4477
5	ASB	Cylinder Head Pressure Test Kit	4910-01-583-5562	ZTSE4289A
6	ASB	DIN Module Removal Kit	4910-01-573-0792	2504954C1
7	ASB	Forward Repair System (FRS)	4940-01-463-7940	SC4940-95-E41

MAINTENANCE ALLOCATION CHART - (CONTINUED)

TOOLS OR TEST EQUIPMENT REF CODE	MAINTENANCE LEVEL	NOMENCLATURE	NATIONAL STOCK NUMBER	TOOL NUMBER
8	ASB	General Mechanic's Tool Kit (GMTK)	5180-01-548-7634	PD484
9	ASB	Guide stud set	4910-01-583-5333	ZTSE4375
10	ASB	Harness, 500-ohm resistor	4940-01-573-0921	ZTSE4497
11	ASB	Harness, banana plug	4940-01-573-0178	ZTSE4498
12	ASB	Harness, fuel injector test	6150-01-568-5804	ZTSE4401
13	ASB	Harness, relay breakout	4940-01-573-0843	ZTSE4596
14	ASB	Harness, relay breakout	6150-01-573-0488	ZTSE4674
15	ASB	Harness, sensor breakout, injection control pressure	6150-01-573-0478	ZTSE4662
16	ASB	Heater, damper	4520-01-568-5859	ZTSE4384
17	ASB	Installer, crankshaft front wear sleeve	4940-01-573-0105	ZTSE3004B
18	ASB	Installer, rear oil seal and wear sleeve	4910-01-583-2100	ZTSE4749
19	ASB	Jack, floor, 20-ton	4910-01-583-5138	DFP-554
20	ASB	Kit, plug, injection control pressure	4910-01-573-0902	ZTSE4655
21	ASB	Manometer, slack tube	6685-00-857-4895	1211-60
22	ASB	Maintenance Support Device (MSD)	6625-01-573-3383	DG-MRAP-CDK
23	ASB	Pressure Test Kit	2590-01-568-6524	ZTSE4409
24	ASB	Puller, pitman arm Quality	5120-01-579-6906	3591842K
25	ASB	Connect Tool Kit Refrigerant	2590-01-568-6384	991843C91
26	ASB	recovery station	4250-01-411-7240	17800B
27	ASB	Refrigeration Ordnance Service Tool Kit	5180-00-596-1474	SC 5180-90-CL-N18
28	ASB	Snapping Pliers Tool Kit	5120-01-429-7455	SRPC112
29	ASB	Set, slide hammer	4910-01-557-0175	1001094
30	ASB	Sling, nylon	2835-01-078-2080	EE2-802D-7FT TYPE 4
31	ASB	Socket, hex, 3/4-inch drive, 3/4 inch	5120-01-437-3788	LAW124E
32	ASB	Standard Automotive Tool Set (SATS)	4910-01-490-6453	SC 4910-95-A81

MAINTENANCE ALLOCATION CHART - (CONTINUED)

TOOLS OR TEST EQUIPMENT REF CODE	MAINTENANCE LEVEL	NOMENCLATURE	NATIONAL STOCK NUMBER	TOOL NUMBER
33	ASB	Straightedge	5210-00-264-6400	MIL-S-15769
34	ASB	Tee, 2-way breakout	4940-01-573-0147	ZTSE4483
35	ASB	Tee, 3-wire pressure sensor breakout	5935-01-568-6297	ZTSE4347
36	ASB	Tee, Accelerator Position Sensor (APS)/Idle Validation Switch (IVS), sensor breakout	4940-01-573-0152	ZTSE4485
37	ASB	Tee, breakout	4940-01-573-0154	ZTSE4486
38	ASB	Tee, Injection Control Pressure (ICP) adapter	4730-01-573-0280	ZTSE4594
39	ASB	Tee, IPR, breakout	4940-01-573-0150	ZTSE4484
40	ASB	Terminal Test Kit	6625-01-581-2453	ZTSE4435C
41	ASB	Tester, Charge Air Cooler (CAC) leak	4940-01-573-0128	ZTSE4341
42	ASB	Terminal Kit		MWH30005
43	ASB	USB cable, 1C4 interface	4940-01-573-0862	ZTSE4632
44	ASB	Wear sleeve remover	4910-01-583-5760	ZTSE4404
45	ASB	Wheel alignment gauge	5210-01-223-3701	69804

Table 3. Remarks.

REMARKS CODE	REMARKS
A	Crew performs PMCS
B	Remove Belly Armor
C	Remove rocker cover
D	Remove engine oil cooler
E	Visual inspection of leaks under vehicle
F	Remove transmission
G	Recovery/Recharging Station required
H	Trained personnel wearing proper NBC equipment required. Contact unit NBC NCO or NBC Officer for assistance.

END OF WORK PACKAGE

FIELD MAINTENANCE
EXPENDABLE AND DURABLE ITEMS LIST

Scope

This work package lists expendable and durable items that you will need to operate and maintain the M1224 and M1224A1. This list is for information only and is not authority to requisition the listed items. These items are authorized to you by CTA 50-970, Expendable/Durable Items (Except Medical, Class V Repair Parts, and Heraldic Items), CTA 50-909, Field and Garrison Furnishings and Equipment or CTA 8-100, Army Medical Department Expendable/Durable Items.

Explanations of Columns in the Expendable/Durable Items List

Column (1) Item No. This number is assigned to the entry in the list and is referenced in the narrative instructions to identify the item (e.g., Use brake fluid (WP 0098, item 5)).

Column (2) Level. This column identifies the lowest level of maintenance that requires the listed item (C = Crew, O = AMC, F = Maintainer or ASB, H = Below Depot or TASMG, D = Depot).

Column (3) National Stock Number (NSN). This is the NSN assigned to the item which you can use to requisition it.

Column (4) Item Name, Description, Part Number/(CAGEC). This column provides the other information you need to identify the item. The last line below the description is the part number and the Commercial and Government Entity Code (CAGEC) (in parentheses).

Column (5) U/I. Unit of Issue (U/I) code shows the physical measurement or count of an item, such as gallon, dozen, gross, etc.

Table 1.

(1) ITEM NUMBER	(2) LEVEL	(3) NATIONAL STOCK NUMBER (NSN)	(4) ITEM NAME, DESCRIPTION, PART NUMBER AND (CAGEC)	(5) U/I
1	F		Adhesion promoter, 3M 70-0064-0673-3 (34360)	GL
2	F	8040-01-406-8116	Adhesive, sealant, caulk gun tube dispenser (0PMN0)	CA
3	F	8040-01-145-1768	Adhesive, RTV silicone sealant, caulk gun tube dispenser RTV106 (01139)	TU
4	F	8040-01-147-6849	Adhesive, 3M weatherstrip and gasket 8008 (34360)	TU
5	F	6850-01-441-3221	Antifreeze AA52624-I-A (58536)	GL
6	F	8030-00-913-8934	Antiseize compound, brush-in-bottle dispenser 51606 (05972)	CN
7	F	5306-01-574-8680	Bolt, machine, M12-1.25 x 50 1850815C2 (338X5)	EA
8	F	7920-00-252-4084	Brush, adhesive 38B1725 (90142)	DZ
9	F	6850-01-167-0678	Cleaner, brake parts 05088 (10136)	CN
10	F	6850-01-381-4401	Cleaning compound, solvent, (0K209)	DR

EXPENDABLE AND DURABLE ITEMS LIST - (CONTINUED)

(1) ITEM NUMBER	(2) LEVEL	(3) NATIONAL STOCK NUMBER (NSN)	(4) ITEM NAME, DESCRIPTION, PART NUMBER AND (CAGEC)	(5) U/I
11	F	5350-00-268-3116	Cloth, abrasive, emery cloth, fine-grit ASTM E11 (81346)	RO
12	F	7920-00-044-9281	Cloth, cleaning, low-lint MIRACLEWIPEL001 (51200)	BX
13	C	8040-01-531-8302	Compound, corrosion preventive CA-LUBRIPLATE/130AA (73219)	CN
14	F	5120-00-679-5655	Dispenser, sealant, caulk gun GGG-C-120 TY3 (80244)	EA
15	C	6810-01-070-1784	Distilled water 6170-18-7 (53390)	BT
16	F	4240-00-017-9767	Faceshield, industrial 11040124-7 (18876)	PR
17	F	5325-01-556-6733	Fastener, trim, ribbed, pine tree 6010241C1 (338X5)	EA
18	F	8415-01-283-3866	Glove, nitrile, large C-4542 (53547)	PR
19	F	8415-00-268-8350	Gloves, leather A-A-50016 (58536)	PR
20	F	4240-00-052-3776	Goggles, industrial ANSI Z87.1 (80204)	PR
21	F	9150-01-197-7693	Grease, automotive and artillery MIL-PRF-10924 (81349)	CA
22	F	9150-01-573-1110	Grease, silicone insulated electric motor 67VR (1PBQ8)	TU
23	F	9150-01-556-7102	Grease, silicone insulated electric motor, high temperature 291126N (6853)	CN
24	F	4720-01-065-0809	Hose, nonmetallic, 3/8 in. ID, 18 in. long L2643545 (338X5)	FT
25	F	9150-00-082-7524	Hydraulic fluid, petroleum base MIL-PRF-5606 (81349)	CN
26	F	6810-01-075-5546	Isopropyl alcohol 7618-19-4 (53390)	BT
27	F	9150-00-402-4478	Lubricating oil, engine, MIL-PRF-2104 CON0C0DN600FLUIDTYPE1 (15445)	CN
28	F	9150-01-048-4591	Lubricating oil, gear, axle-differential - SAE 85W/140 M2105-1-85W140 (81349)	QT
29	F	9150-01-035-5390	Lubricating oil, gear, transfer case fluid - high-temperature M2105-1-75W 90 (81349)	QT

EXPENDABLE AND DURABLE ITEMS LIST - (CONTINUED)

(1) ITEM NUMBER	(2) LEVEL	(3) NATIONAL STOCK NUMBER (NSN)	(4) ITEM NAME, DESCRIPTION, PART NUMBER AND (CAGEC)	(5) U/I
30	F	9150-01-422-9329	Lubricating oil, gear, transfer case fluid - low-temperature J2360 (81349)	QT
31	F	9150-01-546-5096	Lubricating oil, refrigerant compressor, PAG 46 refrigerant compressor oil RD-5-7166-1P (62534)	QT
32	F	7050-00-961-7663	Lubriplate, lubricant, petroleum ST40334 (90536)	CN
33	F	7690-00-422-9673	Marker, identification, wire PWM-1-45 (85480)	PK
34	F	7240-00-138-7985	Measure, liquid 3126-00 (3T537)	EA
35	F	7510-01-015-3244	Paint stick, marking 1660T26 (39428)	DZ
36	F	5350-0-0598-6105	Paper, abrasive, 60-grit, fine, 9 in. x 10 in. sheets A-A-1202 (58536)	HD
37	F	4730-00-801-8186	Plug, pipe, 1/2-in. NPT S-915-A (15434)	EA
38	F	8040-01-498-3919	Primer, adhesive, 3M adhesive primer 94 70-0160-5478-8 (76381)	QT
39	F	7920-00-205-1711	Rag, wiping, unbleached cotton and synthetic cotton 7920-00-205-1711 (80244)	BE
40	F	8030-01-470-6256	Sealant, fuel tank, 2-part squeeze cartridge dispenser PR-1440 B-1/2 (82574)	CO
41	F	8030-00-551-1059	Sealing compound, squeeze tube dispenser FORM-A-GASKET 2 (62377)	TU
42	F	8030-00-252-3391	Sealing compound, squeeze tube dispenser MIL-S-45180 (81349)	TU
43	F	8030-01-508-9181	Sealing compound, Ultra Grey RTV silicone gasket maker 18718 (05972)	TU
44	F	8030-00-118-0012	Sealing compound, thread, squeeze bottle dispenser ASTM D5363 (81346)	BT
45	F	8030-01-104-5392	Sealing compound, 242 24221 (05972)	BT
46	F	8030-01-220-6400	Sealing compound, 635 retaining compound, squeeze bottle dispenser 63531 (05972)	BT

EXPENDABLE AND DURABLE ITEMS LIST - (CONTINUED)

(1) ITEM NUMBER	(2) LEVEL	(3) NATIONAL STOCK NUMBER (NSN)	(4) ITEM NAME, DESCRIPTION, PART NUMBER AND (CAGEC)	(5) U/I
47	F	8030-01-579-4656	Sealing compound, (0PMN0)	BX
48	F	3439-01-026-1084	Solder, tin alloy, rosin core SN60WRMAP3 0.063 1LB (81346)	SL
49	F	9905-00-537-8955	Tag, marker, wire, plain tags with twist wires 9905-00-537-8955 (64067)	BD
50	F	8030-00-889-3535	Tape, antiseizing, pipe sealing A-A-58092 (58536)	RO
51	F	5640-00-103-2254	Tape, duct 1791K70 (39428)	RO
52	F	5970-01-195-3964	Tape, electrical SCOTCHX-1245 (75037)	RO
53	F	7510-00-685-4963	Tape, pressure sensitive adhesive, 3/4-inch masking MIL-T-21595 (81349)	RO
54	F	6830-01-412-6362	Refrigerant, R-134 – 30 lbs 8935-3130 (2S827)	CY
55	F	5180-00-329-3318	Tool kit, window glass installation, self-sealing weather strip, two-sided insulation 201-1021 (55899)	RO
56	F	4720-01-143-2007	Tubing, heatshrink, sealed (various sizes) S17552-03 (99932)	FT
57	F	9505-00-293-4208	Wire, nonelectrical, safety wire, 16-gauge, soft annealed black wire MS20995C32 (80205)	EA

END OF WORK PACKAGE

FIELD MAINTENANCE
TOOL IDENTIFICATION LIST

Table 1. Tool Identification List.

(1) ITEM NO.	(2) ITEM NAME	(3) NATIONAL STOCK NUMBER (NSN)	(4) PART NUMBER/ (CAGEC)	(5) REFERENCE
1	Adapter, crankcase pressure test	4940-01-573-0113	ZTSE4039 (45225)	TM 9-2355-106-23P
2	Adapter, socket wrench, 3/8-inch drive female - 1/2-inch male		KTC S0658 (00NS2)	SATS SC 4910-95-A81
3	Adapter, socket, wrench drive, 1/4-inch male - 3/8-inch female		KTC S0657 (00NS2)	SATS SC 4910-95-A81
4	Adapter, socket, wrench drive, 3/4-inch female - 1/2-inch male	5120-01-355-1894	GLAS1E (55719)	FRS SC 4940-95-E42
5	Adapter, socket, wrench drive, 3/4-inch male - 1/2-inch female		KTC S0660 (00NS2)	SATS SC 4910-95-A81
6	Adaptor, ICP	4920-01-568-6355	ZTSE4359 (338X5)	TM 9-2355-106-23P
7	Analyzer, battery and charging system		KTC S6602 (00NS2)	SATS SC 4910-95-A81
8	Attachment, screwdriver, Torx bit, 1/4-inch drive, T20		KTC S0285 (00NS2)	SATS SC 4910-95-A81
9	Attachment, screwdriver, Torx bit, 1/4-inch drive, T27		KTC S0287 (00NS2)	SATS SC 4910-95-A81
10	Attachment, screwdriver, Torx bit, 1/4-inch drive, T40		KTC S0289 (00NS2)	SATS SC 4910-95-A81
11	Attachment, screwdriver, Torx bit, 3/8-inch drive, T50		KTC S0292 (00NS2)	SATS SC 4910-95-A81
12	Bar, breaker, 1/2-inch drive, 18-inch OAL, chrome		SN18B (55719)	FRS SC 4940-95-E42
13	Bar, breaker, 3/4-inch drive, chrome		L8112A (55719)	FRS SC 4940-95-E42
14	Battery filler, gravity		KTC S0130 (00NS2)	SATS SC 4910-95-A81
15	Battery Service Kit		KTC S0132 (00NS2)	SATS SC 4910-95-A81
16	Belly Armor Removal/Installer Kit	4940-01-573-0094	ZTSE4903 (45225)	TM 9-2355-106-23P
17	Bender set, tube, hand-actuated, 5/8-inch		100-58 (55719)	FRS SC 4940-95-E42
18	Bit, drill, standard, cobalt, jobber length, 3/16-inch		316-CO (55719)	FRS SC 4940-95-E42
19	Blind Rivet Tool Kit		D-100-MIL-1 (55719)	FRS SC 4940-95-E42
20	Block, filler, wood	5510-01-484-6776	RIA149431 (55719)	FRS SC 4940-95-E42
21	Box, breakout, Electronic System Controller (ESC)	4940-01-573-0141	ZTSE4477 (45225)	TM 9-2355-106-23P
22	Brush, wire, scratch		KTC S0148 (00NS2)	SATS SC 4910-95-A81
23	Cap and plug set	5340-00-450-5718	10935405 (55719)	FRS SC 4940-95-E42

TOOL IDENTIFICATION LIST - (CONTINUED)

(1) ITEM NO.	(2) ITEM NAME	(3) NATIONAL STOCK NUMBER (NSN)	(4) PART NUMBER/ (CAGEC)	(5) REFERENCE
24	C-clamp, deep throat, 0-6 inch capacity	5120-00-180-0909	406 (55719)	FRS SC 4940-95-E42
25	Crimping tool, terminal	5120-01-374-8936	KTC S0159 (00NS2)	SATS SC 4910-95-A81
26	Cylinder Head Pressure Test Kit	4910-01-583-5562	ZTSE4289A (45225)	TM 9-2355-106-23P
27	Dial indicator set		KTC S1019 (00NS2)	SATS SC 4910-95-A81
28	DIN Module Removal Kit	4910-01-573-0792	2504954C1 (338X5)	TM 9-2355-106-23P
29	Drill, hand, VSR, electric, 3/8-inch	5130-01-396-6314	DW223G (55719)	FRS SC 4940-95-E42
30	Electrical Contact Tool Kit	5180-00-876-9336	DMC986 (55719)	FRS SC 4940-95-E42
31	Extension, 3-inch OAL, 3/4-inch drive, chrome		KTC S0376 (00NS2)	SATS SC 4910-95-A81
32	Extension, 8-inch, 3/4-inch drive, chrome		KTC S0377 (00NS2)	SATS SC 4910-95-A81
33	Flaring and Cutting Kit		TF528DE2 (55719)	FRS SC 4940-95-E42
34	Fluid gun, direct delivery		KTC S0219 (00NS2)	SATS SC 4910-95-A81
35	Funnel, flexible spout, 1 qt. capacity		KTC S0207 (00NS2)	SATS SC 4910-95-A81
36	Gage, feeler, standard, 0.003-0.018-inch, 25 pieces		000AA (55719)	FRS SC 4940-95-E42
37	General Mechanic's Tool Kit (GMTK)	5180-01-548-7634	PD484 (19200)	SC 5180-95-B48
38	Gloves, rubber		RI60411 (55719)	FRS SC 4940-95-E42
39	Gloves, welders		820L (55719)	FRS SC 4940-95-E42
40	Grease Gun Adapter Kit		KTC S0124 (00NS2)	SATS SC 4910-95-A81
41	Grease gun, pneumatic		KTC S0217 (55719)	FRS SC 4940-95-E42
42	Guide pin set	4910-01-583-5333	ZTSE4375 (45225)	TM 9-2355-106-23P
43	Gun, air		KTC S0142 (00NS2)	SATS SC 4910-95-A81
44	Hammer, hand, soft face, dead blow, 10 oz		KTC S0222 (00NS2)	SATS SC 4910-95-A81
45	Hammer, hand, soft face, dead blow, 52 oz		KTC S0221 (00NS2)	SATS SC 4910-95-A81
46	Hammer, hand	5120-01-604-4892	BD-8ESG (55719)	FRS SC 4940-95-E42
47	Handle, ratchet, 3/4-inch drive, 17 inches long		KTC S0374 (00NS2)	SATS SC 4910-95-A81
48	Harness, 500-ohm resistor	4940-01-573-0921	ZTSE4497 (45225)	TM 9-2355-106-23P

TOOL IDENTIFICATION LIST - (CONTINUED)

(1) ITEM NO.	(2) ITEM NAME	(3) NATIONAL STOCK NUMBER (NSN)	(4) PART NUMBER/ (CAGEC)	(5) REFERENCE
49	Harness, Banana Plug	4940-01-573-0178	ZTSE4498 (45225)	TM 9-2355-106-23P
50	Harness, fuel injector test	6150-01-568-5804	ZTSE4401 (45225)	TM 9-2355-106-23P
51	Harness, relay breakout	4940-01-573-0843	ZTSE4596 (45225)	TM 9-2355-106-23P
52	Harness, relay breakout	6150-01-573-0488	ZTSE4674 (45225)	TM 9-2355-106-23P
53	Harness, Sensor Breakout, Injection Control	6150-01-573-0478	ZTSE4662 (45225)	TM 9-2355-106-23P
54	Heat gun	4940-01-391-7046	PH1100 (55719)	FRS SC 4940-95-E42
55	Heater, damper	4520-01-568-5859	ZTSE4384 (45225)	TM 9-2355-106-23P
56	Hex key set, metric		KTC S0239 (00NS2)	SATS SC 4910-95-A81
57	Installer, crankshaft front wear sleeve	4940-01-573-0105	ZTSE3004B (45225)	TM 9-2355-106-23P
58	Installer, rear oil seal and wear sleeve	4910-01-583-2100	ZTSE4749 (45225)	TM 9-2355-106-23P
59	Jack, floor, 20-ton	4910-01-583-5138	DFP-554 (00NS2)	SATS SC 4910-95-A81
60	Jack, hydraulic, bottle, 20-ton capacity		D51126 (55719)	FRS SC 4940-95-E42
61	Lift, Transmission and Differential	4910-00-585-3622	KTC S6604 (00NS2)	SATS SC 4910-95-A81
62	Jackstand, 10-ton, 19-28.5-inches		D41608 (55719)	FRS SC 4940-95-E42
63	Jackstand, 10-ton, 30-52-inches	4910-01-583-5140	KTC S10001 (00NS2)	SATS SC 4910-95-A81
64	Kit, Plug, Injection Control Pressure	4940-01-573-0902	ZTSE4655 (45225)	TM 9-2355-106-23P
65	Knife, utility, retractable		WK5V (55719)	FRS SC 4940-95-E42
66	Lift, wheel, truck	4910-00-554-5983	KTC S6606 (00NS2)	SATS SC 4910-95-A81
67	Lifting device		2-195-1-10005 (19204)	
68	Lifting sling		KTC S1051 (00NS2)	SATS SC 4910-95-A81
69	Manometer, Slack Tube	6685-00-857-4895	1211-60 (85274)	TM 9-2355-106-23P
70	Maintenance Support Device (MSD)	6625-01-573-3383	DG-MRAP-CDK (1J1T6)	TM 9-2355-106-23P
71	Measure, liquid, 2 qt		KTC S0251 (00NS2)	SATS SC 4910-95-A81
72	Meter, clamp-on		275 (55719)	FRS SC 4940-95-E42

TOOL IDENTIFICATION LIST - (CONTINUED)

(1) ITEM NO.	(2) ITEM NAME	(3) NATIONAL STOCK NUMBER (NSN)	(4) PART NUMBER/ (CAGEC)	(5) REFERENCE
73	Multimeter		DM4010 (11707)	GMTK SC 5180-95-B48
74	Multiplier, torque		KTC S0253 (00NS2)	SATS SC 4910-95-A81
75	Pan, drain, 5-gal. capacity		KTC S0255 (00NS2)	SATS SC 4910-95-A81
76	Pneumatic Abrasive Cutting Tool Kit		KTC S0701 (00NS2)	SATS SC 4910-95-A81
77	Pressure Test Kit	2590-01-568-6524	ZTSE4409 (45225)	TM 9-2355-106-23P
78	Puller set, mechanical		KTC S0269 (00NS2)	SATS SC 4910-95-A81
79	Puller, mechanical, steering wheel, 4 5/8-inch spread		KTC S0270 (00NS2)	SATS SC 4910-95-A81
80	Puller, pitman arm	5120-01-579-6906	3591842K (78222)	TM 9-2355-106-23P
81	Punch, 3/8 inch, 3/16 inch pt		KTC S6391 (00NS2)	SATS SC 4910-95-A81
82	Quality Connect Tool Kit	2590-01-568-6384	991843C91 (338X5)	TM 9-2355-106-23P
83	Radiator Test Kit		SVTS262KIT (55719)	FRS SC 4940-95-E42
84	Refrigerant recovery station	4130-01-550-8557	17800B (45225)	5180-95-N18
85	Refrigeration Ordnance Service Tool Kit	5180-00-596-1474	SC 5180-90-CL-N18 (50980)	5180-95-N18
86	Scale, weighing		IN-050M (55719)	FRS SC 4940-95-E42
87	Scraper, gasket		KTC S0280 (00NS2)	SATS SC 4910-95-A81
88	Screwdriver, round shank, cross-tip, #4 tip, 13.5 inch		KTC S0334 (00NS2)	SATS SC 4910-95-A81
89	Screwdriver, Torx, T27, 4-inch		KTC S0344 (00NS2)	SATS SC 4910-95-A81
90	Set, slide hammer	4910-01-557-0175	1001094 (1EFH8)	TM 9-2355-106-23P
91	Sling, nylon		KTC S1051 (00NS2)	SATS SC 4910-95-A81
92	Snapping Pliers Tool Kit		KTC S0260 (00NS2)	SATS SC 4910-95-A81
93	Soapstone		FL5 (55719)	FRS SC 4940-95-E42
94	Socket driver, 3/8 inch drive, 6 mm Allen head		FAM6E (55719)	FRS SC 4940-95-E42
95	Socket standard, 1/2-inch drive, 6 point, 1-5/16 inch		KTC S0585 (00NS2)	SATS SC 4910-95-A81
96	Socket, bearing locknut, 6 pt, 4-inch		ANS1914A (55719)	FRS SC 4940-95-E42
97	Socket, bearing locknut, 8 pt, 4-7/8-inch		ANS1919A (55719)	FRS SC 4940-95-E42

TOOL IDENTIFICATION LIST - (CONTINUED)

(1) ITEM NO.	(2) ITEM NAME	(3) NATIONAL STOCK NUMBER (NSN)	(4) PART NUMBER/ (CAGEC)	(5) REFERENCE
98	Socket, deep well, 1/2-inch drive, 6 pt, 15/16 inch		KTC S0579 (00NS2)	SATS SC 4910-95-A81
99	Socket, deep well, 3/4-inch drive, 6 pt, 1-1/4 inch		SFS241 (55719)	FRS SC 4940-95-E42
100	Socket, deep well, 3/8-inch drive, 6 pt, 15 mm		KTC S0553 (00NS2)	SATS SC 4910-95-A81
101	Socket, deep, 3/8-inch drive, 6 pt, 1-inch, chrome		KTC S0511 (00NS2)	SATS SC 4910-95-A81
102	Socket, deep-well, 1/2-inch drive, 12 pt, 1-1/2 inch, chrome		S481 (55719)	FRS SC 4940-95-E42
103	Socket, hex, 3/4-inch drive, 3/4 inch	5120-01-437-3788	LAW124E (55719)	TM 9-2355-106-23P
104	Socket, impact, 3/4-inch drive, 6 pt, 1-1/8-inch		KTC S0972 (00NS2)	SATS SC 4910-95-A81
105	Socket, impact, deep, 1/2 drive, 6 pt, 1-1/8 inch		SIM360 (55719)	FRS SC 4940-95-E42
106	Socket, socket wrench, 1/2-inch drive, 6 pt, deep, 1-1/16-inch		KTC S0623 (00NS2)	SATS SC 4910-95-A81
107	Socket, socket wrench, 3/4-inch drive, 12 pt, 15/16-inch		KTC S0382 (00NS2)	SATS SC 4910-95-A81
108	Socket, socket wrench, 3/8-inch drive, 6 pt, deep, 10 mm		KTC S0548 (00NS2)	SATS SC 4910-95-A81
109	Socket, standard, 3/4-inch drive, 12 pt, 1-5/16 inch		KTC S0974 (00NS2)	SATS SC 4910-95-A81
110	Socket, standard, 3/4-inch drive, 12 pt, 2-1/4 inch, chrome		LDH722 (55719)	FRS SC 4940-95-E42
111	Socket, standard, impact, 3/4-inch drive, 6 pt, 1-1/4 inch		IM402 (55719)	FRS SC 4940-95-E42
112	Socket, standard, impact, 3/4-inch drive, 6 pt, 1-5/16 inch	5130-00-227-6684	IM422 (55719)	FRS SC 4940-95-E42
113	Soldering gun, 3-wire	3439-00-732-7798	R490 (55719)	FRS SC 4940-95-E42
114	Straightedge	5210-00-264-6400	MIL-S-15769 (81349)	TM 9-2355-106-23P
115	Tee, 2-way breakout	4940-01-573-0147	ZTSE4483 (45225)	TM 9-2355-106-23P
116	Tee, 3-wire pressure sensor breakout	5935-01-568-6297	ZTSE4347 (45225)	TM 9-2355-106-23P
117	Tee, Accelerator Position Sensor (APS)/Idle Validation Switch (IVS), sensor breakout	4940-01-573-0152	ZTSE4485 (45225)	TM 9-2355-106-23P
118	Tee, Breakout	4940-01-573-0154	ZTSE4486 (45225)	TM 9-2355-106-23P
119	Tee, Injection Control Pressure (ICP) adapter	4730-01-573-0280	ZTSE4594 (45225)	TM 9-2355-106-23P
120	Tee, IPR, Breakout	4940-01-573-0150	ZTSE4484 (45225)	TM 9-2355-106-23P
121	Terminal Kit		MWH30005 (55719)	FRS SC 4940-95-E42

TOOL IDENTIFICATION LIST - (CONTINUED)

(1) ITEM NO.	(2) ITEM NAME	(3) NATIONAL STOCK NUMBER (NSN)	(4) PART NUMBER/ (CAGEC)	(5) REFERENCE
122	Terminal Test Kit	6625-01-581-2453	ZTSE4435C (30US2)	TM 9-2355-106-23P
123	Tester, antifreeze solution/battery specific gravity		KTC S0699 (00NS2)	SATS SC 4910-95-A81
124	Tester, Charge Air Cooler (CAC) leak	4940-01-573-0128	ZTSE4341 (45225)	TM 9-2355-106-23P
125	Tire inflator		KTC S0236 (00NS2)	SATS SC 4910-95-A81
126	Transmission jack, 1 ton jack, 48 in. x 72 in.		KTC S0257 (00NS2)	SATS SC 4910-95-A81
127	USB Cable, 1C4 Interface	4940-01-573-0862	ZTSE4632-USB (45225)	TM 9-2355-106-23P
128	Vise, machinist's, 4-inch		KTC S0725 (00NS2)	SATS SC 4910-95-A81
129	Wear sleeve remover	4910-01-583-5760	ZTSE4404 (00NS2)	SATS SC 4910-95-A81
130	Wheel Alignment Gauge	5210-01-223-3701	S6603 (00NS2)	SATS SC 4910-95-A81
131	Wheel, abrasive, type 27		KTC S0701 (00NS2)	SATS SC 4910-95-A81
132	Wrench, combination, 1-1/2 inch		KTC S0793 (00NS2)	SATS SC 4910-95-A81
133	Wrench, combination, 1-1/4 inch		KTC S0756 (00NS2)	SATS SC 4910-95-A81
134	Wrench, combination, 1-3/8 inch		KTC S0791 (00NS2)	SATS SC 4910-95-A81
135	Wrench, combination, standard length, 12 pt, 1-1/2 inch, chrome	5120-01-399-8798	OEX488 (55719)	FRS SC 4940-95-E42
136	Wrench, combination, standard length, 12 pt, 1-1/8 inch chrome		KTC S0788 (00NS2)	SATS SC 4910-95-A81
137	Wrench, combination, standard length, 12 pt, 1-1/8 inch, chrome	5120-01-228-9516	OEX36B (55719)	FRS SC 4940-95-E42
138	Wrench, combination, standard length, 12 pt, chrome 32 mm	5120-01-349-1460	OEXM320B (55719)	FRS SC 4940-95-E42
139	Wrench, filter, strap		KTC S0982 (00NS2)	SATS SC 4910-95-A81
140	Wrench, pipe, adjustable	5120-01-399-8985	PW12C (55719)	FRS SC 4940-95-E42
141	Wrench, torque, 20-100 lb-ft, 3/8-inch drive		1002MFRMHSS (55719)	FRS SC 4940-95-E42
142	Wrench, torque, 40-200 lb-in., 3/8-inch drive	5120-01-400-0233	2002MRMHSS (55719)	FRS SC 4940-95-E42
143	Wrench, torque, 50-250 lb-ft, 1/2-inch drive	5120-01-400-0239	2503MFRMHSS (55719)	FRS SC 4940-95-E42
144	Wrench, torque, 90-600 lb-ft, 3/4-inch drive	5120-01-576-5975	J6020AB (55719)	FRS SC 4940-95-E42
145	Wrench, torque, click, ratcheting, 15-75 lb-ft, 3/8-inch drive		KTC S0989 (00NS2)	SATS SC 4910-95-A81

TOOL IDENTIFICATION LIST - (CONTINUED)

(1) ITEM NO.	(2) ITEM NAME	(3) NATIONAL STOCK NUMBER (NSN)	(4) PART NUMBER/ (CAGEC)	(5) REFERENCE
146	Wrench, torque, dial, 30 lb-in., 1/4-inch drive		KTC S0986 (00NS2)	SATS SC 4910-95-A81
147	Wrench, torque, dial, 300 lb-in., 3/8-inch drive		KTC S0987 (00NS2)	SATS SC 4910-95-A81

END OF WORK PACKAGE

FIELD MAINTENANCE
MANDATORY REPLACEMENT PARTS

MANDATORY REPLACEMENT PARTS LIST

This work package includes a list of all mandatory replacement parts referenced in the task initial setups and procedures. These are items that must be replaced during maintenance whether they have failed or not. This includes items based on usage intervals such as miles, time, etc.

Table 1. Mandatory Replacement Parts

ITEM NO.	PART NUMBER/ CAGEC	NATIONAL STOCK NUMBER (NSN)	NOMENCLATURE	QTY
1	A-1205-V-2648 78500	5331-01-556-5330	Seal	2
2	BX801534 338X5	5340-01-556-4785	Clip	1
3	C-1423 82484	5310-00-180-0277	Lockwasher	2
4	EC35PLA 338X5	5340-01-342-5552	Coupling, pipe	2
5	MS24465-628 80205	5315-00-846-0126	Pin, cotter	4
6	MS51971-4 96906	5310-00-965-1800	Nut	2
7	MS90728-95 96906	5305-00-071-2061	Bolt	2
8	N0304 2-013 02697	5331-00-006-2382	O-ring	2
9	N9015 76761	5310-01-046-0186	Lockwasher	2
10	N9461 76761	5310-01-348-8392	Lockwasher	2
11	NL-210-1 3D6E9	5310-01-082-8578	Locknut	2
12	XB-769 74410	5310-01-150-8599	Locknut	1
13	4760 78500		Shim Kit	1
14	33628 0Y3H3	5310-01-556-4499	Lockwasher	1
15	36007 0Y3H3	5310-01-556-6526	Locknut	4
16	37010 0Y3H3	5310-01-556-6829	Locknut	2
17	40252 0Y3H3	5310-01-556-5967	Lockwasher	1
18	65016 0Y3H3	5315-1-556-4469	Pin, cotter	3
19	65080 0Y3H3	5315-01-556-4472	Pin, cotter	2
20	65612 6853	4120-01-555-5461	Cartridge, desiccant	2
21	103375 338X5	5315-00-730-6396	Pin, cotter	4

Mandatory Replacement Parts - (CONTINUED)

ITEM NO.	PART NUMBER/ CAGEC	NATIONAL STOCK NUMBER (NSN)	NOMENCLATURE	QTY
22	116121 338X5	5310-00-011-6121	Lockwasher	1
23	120380 338X5	5310-01-552-9670	Lockwasher	32
24	120382 338X5	5310-01-556-4486	Lockwasher	14
25	120383 338X5	5310-00-480-6170	Lockwasher	5
26	138479 78640	5310-00-596-7691	Lockwasher	8
27	138572 338X5	5310-01-553-1230	Lockwasher	1
28	203019 06853	5315-00-234-1657	Pin, cotter	1
29	273896 338X5	5310-01-556-5475	Locknut	2
30	9412230 97271	5310-01-194-8489	Locknut	1
31	29503383 73342	5331-01-360-6017	O-ring	1
32	29545779 73342	4330-01-425-7701	Filter Parts Kit, fluid pressure	1
33	29546229 73342	5330-01-360-7826	Seal	1
34	107578821C 62319	5330-01-563-3232	O-ring	6
35	107578822C 62319	5330-01-563-3242	O-ring	2
36	107578823C 62319	5330-01-563-3245	O-ring	1
37	107578824C 62319	5330-01-563-3250	O-ring	4
38	1225-B-496 78500	5365-00-255-6042	Bushing	2
39	1225-B-834 78500	3120-01-179-7532	Bushing	1
40	1225-L-1442 78500	5365-01-556-5439	Bushing, axle shaft	2
41	1225-U-1191 78500	3120-01-566-7140	Bushing	4
42	1229-M-4823 78500	5310-01-571-7019	Washer, shim	2
43	1250-V-1218 78500	5340-01-556-7106	Plug, expansion	1
44	144425H 338X5	5310-01-512-6121	Locknut	22
45	1514759C1 338X5	4730-01-398-8329	Clamp	2
46	1618386C93 338X5	4930-01-555-4840	Filter	1
47	1657366C1	5305-01-338-8155	Screw, cap	4

Mandatory Replacement Parts - (CONTINUED)

ITEM NO.	PART NUMBER/ CAGEC	NATIONAL STOCK NUMBER (NSN)	NOMENCLATURE	QTY
48	1685073C1 338X5	3110-01-556-4598	Bearing, thrust	1
49	1697853C1 338X5	5330-01-466-1618	Seal	1
50	17233R1 89346	5315-01-513-0967	Pin, cotter	1
51	1811036C1 338X5		O-ring	1
52	1812559C1 338X5	6680-01-556-4868	Seal	1
53	1815874C1 338X5	5331-01-556-4882	O-ring	1
54	1815980C1 338X5	5331-01-556-4885	O-ring	1
55	1816722C2 89346	5330-01-556-4888	Gasket	1
56	1817674C1 338X5	2910-01-411-8424	Strainer, fuel	1
57	1817849C3 338X5	5330-01-556-4902	Gasket	1
58	1817867C92 338X5	5330-01-411-1650	Seal	1
59	1818400C1 338X5	5331-01-556-4926	O-ring	1
60	1818402C2 338X5	5331-01-547-4884	O-ring	2
61	1818518C1 338X5	5331-01-556-4929	O-ring	1
62	1818716C5 338X5	5330-01-556-4933	Gasket	1
63	1818727C1 338X5	5330-01-556-4935	Gasket	1
64	1819099C1 338X5	5331-01-437-1285	Seal	1
65	1820353C1 338X5	5330-01-556-4952	Seal	1
66	1820878C2 338X5	5331-01-547-4611	Seal	2
67	1820907C2 338X5	5331-01-556-4960	O-ring	4
68	1820909C1 338X5	5330-01-507-3718	Gasket	1
69	1820920C3 338X5	5330-01-556-4965	Gasket	1
70	1820936C1 338X5	5330-01-556-4966	Gasket	1
71	1821098C2 338X5	5331-01-556-4970	O-ring	4
72	1822120C1 338X5	5330-01-556-4984	Gasket	1

Mandatory Replacement Parts - (CONTINUED)

ITEM NO.	PART NUMBER/ CAGEC	NATIONAL STOCK NUMBER (NSN)	NOMENCLATURE	QTY
73	1822577C1 338X5	2805-01-512-4252	Gasket	1
74	1822588C1 338X5	2910-01-444-8795	Filter	1
75	1823790C1 338X5	5331-01-556-5008	O-ring	1
76	1824735C1 338X5	5331-01-556-5015	O-ring	2
77	1824736C1 338X5	5331-01-556-5016	O-ring	2
78	1824908C1 338X5	5331-01-556-5020	O-ring	1
79	1824954C3 338X5	5306-01-556-5023	Bolt	6
80	1824955C2 338X5	5306-01-556-5024	Bolt	20
81	1824978C1 338X5	5310-01-556-5025	Locknut	1
82	1824979C1 338X5	5331-01-556-5026	O-ring	1
83	1824980C1 338X5	5331-01-556-5028	O-ring	1
84	1824981C1 338X5	5330-01-556-5027	Ring, backup	1
85	1825436C1 338X5	5330-01-347-3726	Gasket	1
86	1825610C1 338X5	5330-01-556-5042	Gasket	1
87	1825685C1 338X5	5330-01-556-5047	Gasket	2
88	1826587C1 338X5	5330-01-437-1284	Gasket	1
89	1830189C2 338X5	5330-01-556-5088	Gasket	1
90	1830362C1 338X5	5330-01-556-5098	Gasket	1
91	1830742C92 338X5	5330-01-508-6977	Gasket kit, injector	1
92	1831483C1 338X5	5340-01-556-5116	O-ring	1
93	1833096C94 338X5	5330-01-556-5123	Oil Seal Kit	1
94	1836075C1 338X5	5331-01-556-5141	O-ring	1
95	1839026C1 338X5	5331-01-556-5148	O-ring	1
96	1841622C1 338X5	5330-01-556-5157	Gasket	1
97	1841992C1 338X5	5330-1-566-5651	Gasket	1
98	1842909C1 338X5	5330-01-556-5164	Gasket	1

Mandatory Replacement Parts - (CONTINUED)

ITEM NO.	PART NUMBER/ CAGEC	NATIONAL STOCK NUMBER (NSN)	NOMENCLATURE	QTY
99	1844447C1 338X5	5331-01-556-5165	O-ring	1
100	2009N-7		O-ring	3
101	2035272C1 338X5	5310-01-564-0408	Locknut	1
102	2037534C1 338X5	5310-01-566-9235	Locknut	4
103	2040956C1 338X5	5320-01-512-9947	Rivet	2
104	2042710C1 338X5	5340-01-591-9993	Cable lock strap	1
105	22068-12 01276	5330-01-211-3121	O-ring	1
106	2257D1174 78500	5315-478-7697	Clip	7
107	2258-H-1230 78500	5360-01-546-2220	Spring	4
108	2258-W-803 78500	5360-01-499-3396	Spring	1
109	2258-Y-1273 3D6E9	5360-01-518-3316	Spring	1
110	2502063C91 338X5	2530-01-556-4691	Retainer	1
111	2503221C1 338X5	4330-01-507-4201	Filter	1
112	2505773C1 338X5	5330-01-556-5274	Gasket	1
113	2506988C1 338X5	4820-01-578-1544	Valve	1
114	2507061C1 338X5	5330-01-556-5317	Gasket	1
115	2507844C1 338X5	5330-01-568-5881	Seal	2
116	253660R2 13446	5330-01-539-4252	Gasket	1
117	25549R1 338X5	5310-01-556-5374	Lockwasher	11
118	2589457C1 338X5	5340-01-556-5398	Clip	1
119	265204R1 338X5	5365-00-846-7660	Sleeve, compression	2
120	289862C1 338X5	5340-00-421-5015	Cable lock strap	30
121	291207C1 338X5	2590-01-513-4557	Cable lock strap	1
122	2XX306158 79788	5330-01-556-6137	Gasket	1
123	30243R1 338X5	5315-01-591-9161	Pin, cotter	1

Mandatory Replacement Parts - (CONTINUED)

ITEM NO.	PART NUMBER/ CAGEC	NATIONAL STOCK NUMBER (NSN)	NOMENCLATURE	QTY
124	306132C1 338X5	5340-01-189-8297	Cable lock strap	70
125	30756R1 338X5	5310-01-512-6137	Locknut	2
126	3113286C1L 338X5	5331-01-563-3270	O-ring	1
127	3113654C1 338X5	5315-01-568-5844	Pin, cotter	2
128	3513117C1 338X5	5306-01-556-5890	Bolt	4
129	3523434C1 338X5	5340-01-556-5900	Clamp	1
130	3523435C1 338X5	4730-01-513-0955	Clamp	1
131	3535854C1 338X5	5306-01-512-2116	Lockbolt	2
132	3535859C1 338X5	5310-01-512-6154	Locknut	4
133	3544557C1 338X5	5340-01-556-5977	Cable lock strap, buttonhead	3
134	3551709C1 338X5	5340-01-556-6045	Cable lock strap	25
135	3553592C1 338X5	5310-01-557-0708	Locknut	4
136	3556343C1 338X5	5340-01-556-6086	Cable lock strap	4
137	3558816C1 89346	5340-01-537-2705	Clip, spring	9
138	3560710C91 338X5	5340-1-556-6111	Cable lock strap	1
139	3562424C1 338X5	4820-01-577-7976	Valve	2
140	3576742C1 338X5	4730-556-6187	Clamp, screw	6
141	3591600C1 338X5	5330-01-556-6208	Gasket	2
142	3601546C1	5310-01-592-8602	Locknut	4
143	3606527C1	5310-01-556-6230	Locknut	1
144	3626607C1 338X5	3940-01-556-6275	Cable lock strap	1
145	3810865C1 338X5	5340-01-556-4708	Cable lock strap	6
146	3819433C1 338X5	5330-01-556-4748	Seal	1
147	3821116C1 338X5	5310-01-555-4987	Locknut	2
148	3821117C2 338X5	5310-01-555-4988	Locknut	9
149	3821118C1 338X5	5310-01-555-4989	Locknut	25

Mandatory Replacement Parts - (CONTINUED)

ITEM NO.	PART NUMBER/ CAGEC	NATIONAL STOCK NUMBER (NSN)	NOMENCLATURE	QTY
150	3822144C1 338X5	2590-01-578-6373	Base, cable lock strap mounting	19
151	386170C1 338X5	5340-01-556-6500	Cable lock strap	3
152	40050R1 338X5	5310-01-556-5260	Locknut	6
153	40066R1 338X5	5310-01-556-6508	Locknut	6
154	40240R1 338X5	5310-01-556-6511	Locknut	4
155	533959R1 338X5	3990-01-589-2739	Cable lock strap	3
156	575359C1 338X5	5320-01-556-6711	Rivet	1
157	591597C2 338X5	5330-01-346-2917	Gasket	1
158	592855C1 338X5	5330-01-556-6727	Seal, oil	1
159	6010241C1 338X5	5325-01-556-6733	Fastener, trim, ribbed	3
160	6-1-5866-17 81337	5310-01-130-9065	Lockwasher	4
161	6410-13B-003 338X5		Filter, engine oil	1
162	691273C1 338X5	5330-30-363-1720	Gasket	1
163	69480R91 338X5	5306-00-481-9792	Bolt	5
164	875522C1 338X5	5331-01-556-6807	O-ring	1
165	876106C1 338X5	5331-01-076-6167	O-ring	1
166	876108C1 338X5	5331-01-556-6809	O-ring	1
167	933965R1 338X5	5310-01-556-6817	Lockwasher	1
168	934948R1 338X5	5310-567-1388	Lockwasher	35
169	9395-C 9K475		Rivet	4
170	9A65337A 3FQN6	5310-01-575-3875	Locknut	1
171			O-ring	1
172			Lockwasher	1
173			Lockwasher	4
174			Lockwasher	4
175	BAC10WL6-16) 81205	5310-01-008-6782	Locknut	2
176			Lockwasher	6

Mandatory Replacement Parts - (CONTINUED)

ITEM NO.	PART NUMBER/ CAGEC	NATIONAL STOCK NUMBER (NSN)	NOMENCLATURE	QTY
177	120382 338X5	5310-01-556-4486	Lockwasher	2
178	MS35338-67 96906	5310-00-011-6121	Lockwasher	3
179			Lockwasher	3
180			Gasket	1
181	22046-16 01276	5330-01-485-1779	O-ring	4
182			Lockwasher	2
183			Lockwasher	2
184			Lockwasher	2
185	40250 0Y3H3	5310-01-556-6816	Lockwasher	2

END OF WORK PACKAGE

RECOMMENDED CHANGES TO PUBLICATIONS AND BLANK FORMS						Use Part II (reverse) for Repair Parts and Special Tool Lists (RPSTL) and Supply Catalogs/Supply Manuals (SC/SM).	DATE <i>Date you filled out this form.</i>
For use of this form, see AR 25-30; the proponent agency is OAASA.							
TO (Forward to proponent of publication or form) (Include ZIP Code) U.S. Army TACOM Life Cycle Management Command ATTN: AMSTA-LCL-MPP/TECH PUBS 6501 E. 11 Mile Road, Warren, MI 48397-5000						FROM (Activity and location) (Include ZIP Code) <i>Your mailing address</i>	
PART I – ALL PUBLICATIONS (EXCEPT RPSTL AND SC/SM) AND BLANK FORMS							
PUBLICATION/FORM NUMBER <i>TM Number</i>						DATE <i>Date of the TM</i>	TITLE <i>Title of the TM</i>
ITEM	PAGE	PARA-GRAPH	LINE	FIGURE NO.	TABLE	RECOMMENDED CHANGES AND REASON (Exact wording of recommended change must be given)	
	0007-3					<i>Figure 2, Item 9 should show a lockwasher. Currently shows a flat washer.</i>	
	0018-2					<i>Cleaning and inspection, Step 6, reference to governor support pin (14) is wrong reference. Reference should be change to (12).</i>	
<h1>SAMPLE</h1>							
TYPED NAME, GRADE OR TITLE <i>Your Name</i>					TELEPHONE EXCHANGE/AUTOVON, PLUS EXTENSION <i>Your Phone Number</i>		SIGNATURE <i>Your Signature</i>

TO (Forward direct to addressee listed in publication) U.S. Army TACOM Life Cycle Management Command ATTN: AMSTA-LCL-MPP/TECH PUBS 6501 E. 11 Mile Road, Warren, MI 48397-5000	FROM (Activity and location) (Include ZIP Code) <i>Your Address</i>	DATE <i>Date you filled out this form</i>
--	---	---

PART II – REPAIR PARTS AND SPECIAL TOOL LISTS AND SUPPLY CATALOGS/SUPPLY MANUALS

PUBLICATION NUMBER <i>TM Number</i>	DATE <i>Date of the TM</i>	TITLE <i>Title of the TM</i>
--	-------------------------------	---------------------------------

PAGE NO.	COLM NO.	LINE NO.	NATIONAL STOCK NUMBER	REFERENCE NO.	FIGURE NO.	ITEM NO.	TOTAL NO. OF MAJOR ITEMS SUPPORTED	RECOMMENDED ACTION
<h1>SAMPLE</h1>								

PART III – REMARKS (Any general remarks, or recommendations, or suggestions for improvement of publications and blank forms. Additional blank sheets may be used if more space is needed.)

TYPED NAME, GRADE OR TITLE <i>Your Name</i>	TELEPHONE EXCHANGE/AUTOVON, PLUS EXTENSION <i>Your Phone Number</i>	SIGNATURE <i>Your Signature</i>
--	--	------------------------------------

RECOMMENDED CHANGES TO PUBLICATIONS AND BLANK FORMS						Use Part II (reverse) for Repair Parts and Special Tool Lists (RPSTL) and Supply Catalogs/Supply Manuals (SC/SM).	DATE
For use of this form, see AR 25-30; the proponent agency is OAASA							
TO (Forward to proponent of publication or form) (Include ZIP Code) U.S. Army TACOM Life Cycle Management Command ATTN: AMSTA-LCL-MPP/TECH PUBS 6501 E. 11 Mile Road, Warren, MI 48397-5000						FROM (Activity and location) (Include ZIP Code)	
PART I – ALL PUBLICATIONS (EXCEPT RPSTL AND SC/SM) AND BLANK FORMS							
PUBLICATION/FORM NUMBER TM 9-2355-106-23-5						DATE 19 November 2012	TITLE MAINTENANCE MANUAL FOR MINE RESISTANT AMBUSH PROTECTED VEHICLE
	PAGE	PARA-GRAPH	LINE	FIGURE NO.	TABLE	RECOMMENDED CHANGES AND REASON	
TYPED NAME, GRADE OR TITLE					TELEPHONE EXCHANGE/AUTOVON, PLUS EXTENSION		SIGNATURE

TO <i>(Forward direct to addressee listed in publication)</i> U.S. Army TACOM Life Cycle Management Command ATTN: AMSTA-LCL-MPP/TECH PUBS 6501 E. 11 Mile Road, Warren, MI 48397-5000	FROM <i>(Activity and location) (Include ZIP Code)</i>	DATE
---	---	-------------

PART II – REPAIR PARTS AND SPECIAL TOOL LISTS AND SUPPLY CATALOGS/SUPPLY MANUALS

PUBLICATION/FORM NUMBER TM 9-2355-106-23-5	DATE 19 November 2012	TITLE MAINTENANCE MANUAL FOR MINE RESISTANT AMBUSH PROTECTED VEHICLE
--	---------------------------------	---

PAGE NO.	COLM NO.	LINE NO.	NATIONAL STOCK NUMBER	REFERENCE NO.	FIGURE NO.	ITEM NO.	TOTAL NO. OF MAJOR ITEMS SUPPORTED	RECOMMENDED ACTION

PART III – REMARKS *(Any general remarks, or recommendations, or suggestions for improvement of publications and blank forms. Additional blank sheets may be used if more space is needed.)*

TYPED NAME, GRADE OR TITLE	TELEPHONE EXCHANGE/AUTOVON, PLUS EXTENSION	SIGNATURE
----------------------------	--	-----------

RECOMMENDED CHANGES TO PUBLICATIONS AND BLANK FORMS						Use Part II (reverse) for Repair Parts and Special Tool Lists (RPSTL) and Supply Catalogs/Supply Manuals (SC/SM).	DATE
For use of this form, see AR 25-30; the proponent agency is OAASA							
TO (Forward to proponent of publication or form) (Include ZIP Code) U.S. Army TACOM Life Cycle Management Command ATTN: AMSTA-LCL-MPP/TECH PUBS 6501 E. 11 Mile Road, Warren, MI 48397-5000						FROM (Activity and location) (Include ZIP Code)	
PART I – ALL PUBLICATIONS (EXCEPT RPSTL AND SC/SM) AND BLANK FORMS							
PUBLICATION/FORM NUMBER TM 9-2355-106-23-5						DATE 19 November 2012	TITLE MAINTENANCE MANUAL FOR MINE RESISTANT AMBUSH PROTECTED VEHICLE
ITEM	PAGE	PARA-GRAPH	LINE	FIGURE NO.	TABLE	RECOMMENDED CHANGES AND REASON	
TYPED NAME, GRADE OR TITLE					TELEPHONE EXCHANGE/AUTOVON, PLUS EXTENSION		SIGNATURE

TO <i>(Forward direct to addressee listed in publication)</i> U.S. Army TACOM Life Cycle Management Command ATTN: AMSTA-LCL-MPP/TECH PUBS 6501 E. 11 Mile Road, Warren, MI 48397-5000	FROM <i>(Activity and location) (Include ZIP Code)</i>	DATE
---	---	-------------

PART II – REPAIR PARTS AND SPECIAL TOOL LISTS AND SUPPLY CATALOGS/SUPPLY MANUALS

PUBLICATION/FORM NUMBER TM 9-2355-106-23-5	DATE 19 November 2012	TITLE MAINTENANCE MANUAL FOR MINE RESISTANT AMBUSH PROTECTED VEHICLE
--	---------------------------------	---

PAGE NO.	COLM NO.	LINE NO.	NATIONAL STOCK NUMBER	REFERENCE NO.	FIGURE NO.	ITEM NO.	TOTAL NO. OF MAJOR ITEMS SUPPORTED	RECOMMENDED ACTION

PART III – REMARKS *(Any general remark, or recommendations, or suggestions for improvement of publications and blank forms. Additional blank sheets may be used if more space is needed.)*

TYPED NAME, GRADE OR TITLE	TELEPHONE EXCHANGE/AUTOVON, PLUS EXTENSION	SIGNATURE
----------------------------	--	-----------

By Order of the Secretary of the Army:

Official:



JOYCE E. MORROW
*Administrative Assistant to the
Secretary of the Army*

1229007

RAYMOND T. ODIERNO
*General, United States Army
Chief of Staff*

By Order of the Secretary of the Air Force:

JANET C. WOLFENBARGER
*General, United States Air Force
Commander, AFMC*

MARK A. WELSH, III
*General, United States Air Force
Chief of Staff*

Distribution:

To be distributed in accordance with the initial distribution number (IDN) 381168 requirements for TM 9-2355-106-23-5.

THE METRIC SYSTEM AND EQUIVALENTS

<p>Linear Measure</p> <p>1 Centimeter = 10 Millimeters = 0.01 Meters = 0.3937 Inches 1 Meter = 100 Centimeters = 1000 Millimeters = 39.37 Inches 1 Kilometer = 1000 Meters = 0.621 Miles</p> <p>Weights</p> <p>1 Gram = 0.001 Kilograms = 1000 Milligrams = 0.035 Ounces 1 Kilogram = 1000 Grams = 2.2 Pounds 1 Metric Ton = 1000 Kilograms = 1 Megagram = 1.1 Short Tons</p> <p>Liquid Measure</p> <p>1 Milliliter = 0.001 Liters = 0.0338 Fluid Ounces 1 Liter = 1000 Milliliters = 33.82 Fluid Ounces</p>	<p>Square Measure</p> <p>1 Sq Centimeter = 100 Sq Millimeters = 0.155 Sq Inches 1 Sq Meter = 10,000 Sq Centimeters = 10.76 Sq Feet 1 Sq Kilometer = 1,000,000 Sq Meters = 0.386 Sq Miles</p> <p>Cubic Measure</p> <p>1 Cu Centimeter = 1,000 Cu Millimeters = 0.06 Cu Inches 1 Cu Meter = 1,000,000 Cu Centimeters = 35.31 Cu Feet</p> <p>Temperature</p> <p>$9/5 C^{\circ} + 32 = F^{\circ}$ $5/9 (F^{\circ} - 32) = C^{\circ}$ 212° Fahrenheit is equivalent to 100° Celsius 90° Fahrenheit is equivalent to 32.2° Celsius 32° Fahrenheit is equivalent to 0° Celsius</p>
--	---

APPROXIMATE CONVERSION FACTORS

To Change	To	Multiply By
Inches	Centimeters	2.540
Feet	Meters	0.305
Yards	Meters	0.914
Miles	Kilometers	1.609
Sq Inches	Sq Centimeters	6.451
Sq Feet	Sq Meters	0.093
Sq Yards	Sq Meters	0.836
Sq Miles	Sq Kilometers	2.590
Acres	Sq Hectometers	0.405
Cubic Feet	Cubic Meters	0.028
Cubic Yards	Cubic Meters	0.765
Fluid Ounces	Milliliters	29.573
Pints	Liters	0.473
Quarts	Liters	0.946
Gallons	Liters	3.785
Ounces	Grams	28.349
Pounds	Kilograms	0.454
Short Tons	Metric Tons	0.907
Pound-Feet	Newton-Meters	1.356
Pounds per Sq Inch	Kilopascals	6.895
Miles per Gallon	Kilometers per Liter	0.425
Miles per Hour	Kilometers per Hour	1.609

To Change	To	Multiply By
Centimeters	Inches	0.394
Meters	Feet	3.280
Meters	Yards	1.094
Kilometers	Miles	0.621
Sq Centimeters	Sq Inches	0.155
Sq Meters	Sq Feet	10.764
Sq Meters	Sq Yards	1.196
Sq Kilometers	Sq Miles	0.386
Sq Hectometers	Acres	2.471
Cubic Meters	Cubic Feet	35.315
Cubic Meters	Cubic Yards	1.308
Milliliters	Fluid Ounces	0.034
Liters	Pints	2.113
Liters	Quarts	1.057
Liters	Gallons	0.264
Grams	Ounces	0.035
Kilograms	Pounds	2.205
Metric Tons	Short Tons	1.102
Newton-Meters	Pound-Feet	0.738
Kilopascals	Pounds per Sq Inch	0.145
Kilometers per Liter	Miles per Gallon	2.354
Kilometers per Hour	Miles per Hour	0.621

PIN: 087255-000